

# Rotary Table/Rack & Pinion Type

## *MSQ Series*

Size: 1, 2, 3, 7, 10, 20, 30, 50, 70, 100, 200

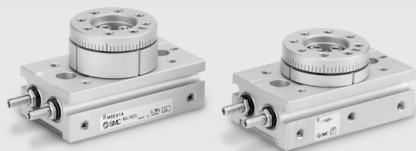

# Compact Rotary Table with Low Table Height

## Easy mounting of workpiece.

### • Table I.D./O.D tolerances

Basic type: **MSQB H9/h9**

High precision type: **MSQA H8/h8**

### • Positioning pin hole

### • Hollow axis

Accommodates wiring and piping for equipment mounted on the table

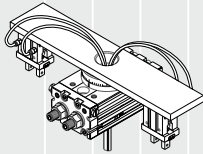

**Table inside and outside diameters**  
For alignment of rotation center and work piece

**Positioning pin hole**  
For position of rotation direction

**Hollow axis**

Size	1	2	3	7
Hollow axis	ø3.5	ø3.8	ø5	ø6

Size	10	20	30	50	70	100	200
Hollow axis	ø6	ø9	ø12	ø13	ø16	ø19	ø24

## Large rolling element bearing

**3 to 4 times** higher axial load  
(compared with the CRQ series)

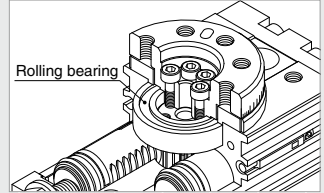

### Basic type MSQB

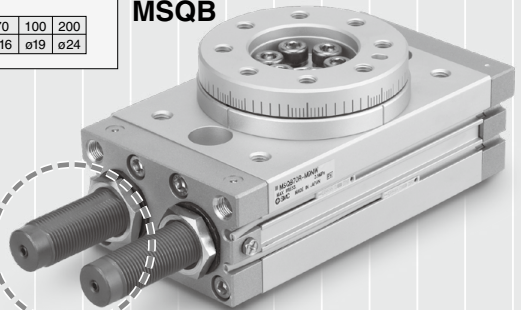

## Pivoting angle adjustment range: 0 to 190°

### With internal shock absorber

**2 to 5 times** more kinetic energy  
(compared with an adjustment bolt)

## Easy mounting of body

- Reference dia: Boss, Hole
- Mounting from 2 directions
- Positioning pin hole

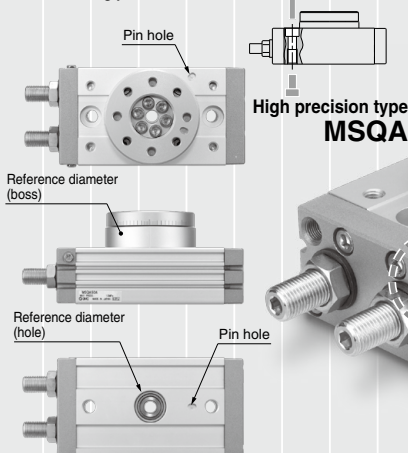

## Movement in direction of table's radial thrust: **0.01 mm or less**

By using high precision bearing, the movement in the direction of table's radial thrust is reduced.

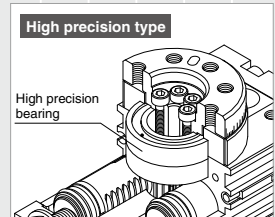

## Piping from 2 directions (front and side) is possible

Piping position can be selected to accommodate mounting conditions

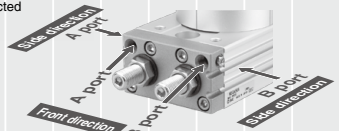

# Rotary Table MSQ Series Rack & Pinion Type

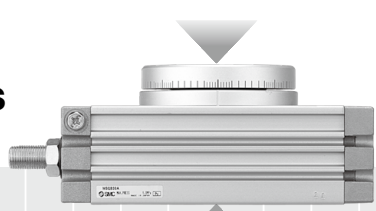

## Small sizes 1, 2, 3, and 7

### Small size and light weight

Measure		mm				Weight (g)
Size	Model	A	B	C	D	
1	MSQB1A	50.5	28	25	16	70
2	MSQB2A	56	30	28	18	105
3	MSQB3A	60	34.5	30.5	20.5	150
7	MSQB7A	73.5	41	34.5	23	250

Full size (Picture of MSQB1A)

### Variety of installation options for space saving

Offers maximum space saving installation by taking advantage of the compact body, space saving wiring and piping.

#### Free mount

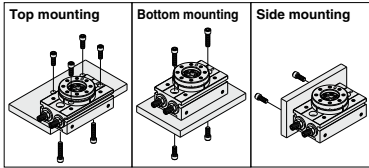

#### Easy center alignment at mounting

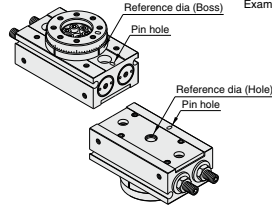

#### Wiring and piping can be selected according to mounting conditions

Example of auto switch and speed controller mounting

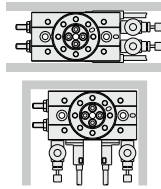

## External shock absorber types

### 4 to 10 times more allowable kinetic energy

(Compared with internal shock absorber type)

2 types of shock absorbers are available, for low energy and high energy.

#### Allowable kinetic energy comparison (for size 30)

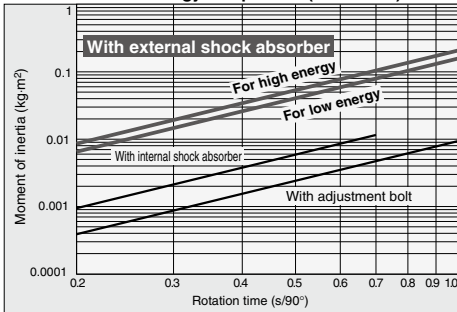

### Total length shortened

Longitudinal mounting space is reduced because there is no protrusion from adjustment bolts or internal shock absorbers.

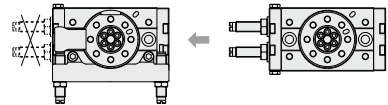
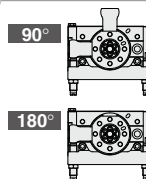
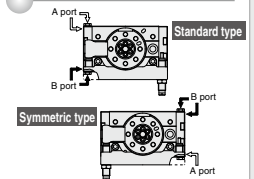

Table height is the same for both types with adjustment bolts or internal shock absorbers.

### Rotation angle: 90°, 180°



### Left / Right symmetric type



## Table Displacement (Reference values)

• The following graphs show the displacement at point A, which is 100 mm apart from the center of rotation, where the load is applied.

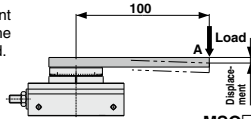

MSQ□1A

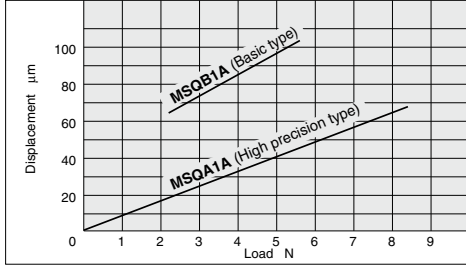

MSQ□10□

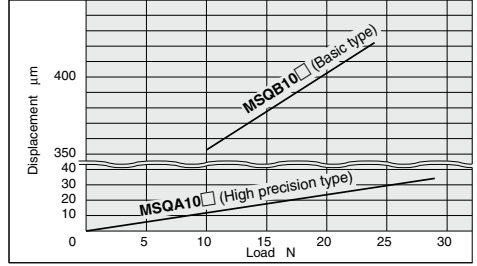

MSQ□2A

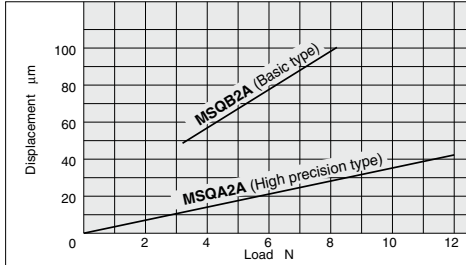

MSQ□20□

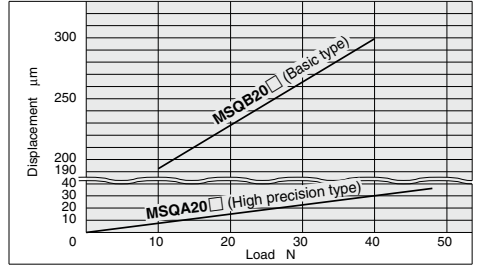

MSQ□3A

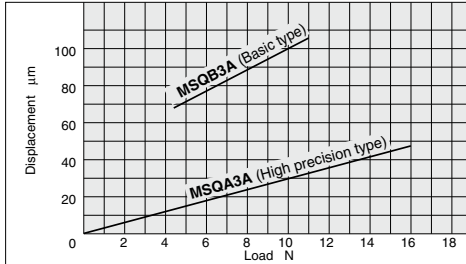

MSQ□30□

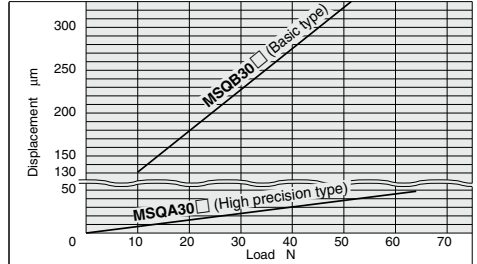

MSQ□7A

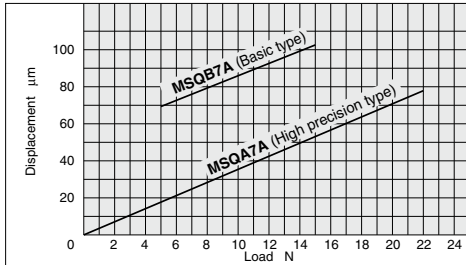

MSQ□50□

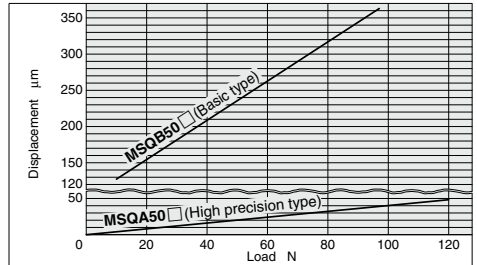

### Table Displacement (Reference values)

- The following graphs show the displacement at point A, which is 100 mm apart from the center of rotation, where the load is applied.

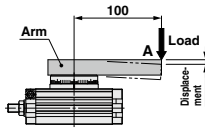

**MSQB70**

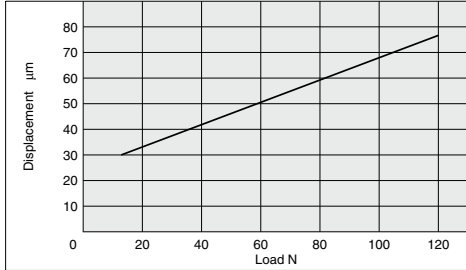

**MSQB100**

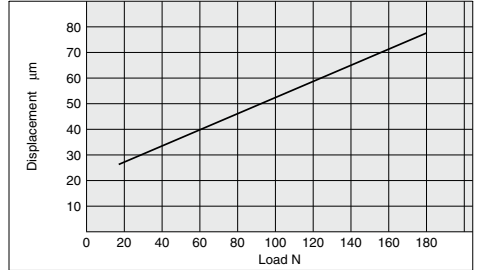

**MSQB200**

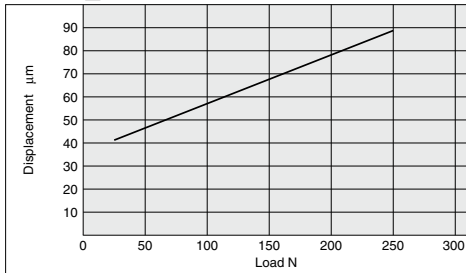

### Rotation Accuracy: Displacement Values at 180° (Reference values)

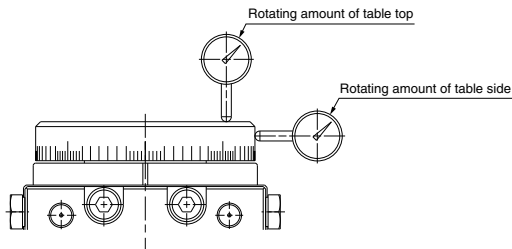

Measuring plate	mm	
Rotating amount of table top	<b>MSQA</b>	<b>MSQB</b>
Rotating amount of table side	0.03	0.1
	0.03	0.1

Values in the table are actual values and not guaranteed values.

# Rotary Table/Rack & Pinion Type

# MSQ Series

Size: 1, 2, 3, 7

## How to Order

High precision type

MSQA 1 A □ - M9BW □

Basic type

MSQB 1 A □ - M9BW □

Size
1
2
3
7

A With adjustment bolt

Number of auto switches

Nil	2 pcs.
S	1 pc.
n	n pcs.

Auto switch type

Nil Without auto switch (built-in magnet)

\* Refer to the table below for auto switch types.

\* The auto switch is included in the package (unmounted).

Port location

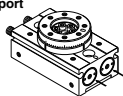
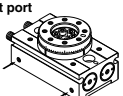
Nil	End port	
E	Front port	

\* The port location cannot be changed after the delivery of the product.

### Moisture Control Tube IDK Series



When operating an actuator with a small diameter and a short stroke at a high frequency, the dew condensation (water droplet) may occur inside the piping depending on the conditions.

Simply connecting the moisture control tube to the actuator will prevent dew condensation from occurring. For details, refer to the [Web Catalog](#).

## Applicable Auto Switches

Refer to pages 929 to 983 for detailed auto switch specification.

Type	Special function	Electrical entry	Indicator light	Wiring (Output)	Load voltage		Auto switch model		Lead wire length (m)*				Pre-wired connector	Applicable load	
					DC	AC	Perpendicular	In-line	0.5 (Nil)	1 (M)	3 (L)	5 (Z)		IC circuit	Relay, PLC
Solid state auto switch	—	Grommet	Yes	3-wire (NPN)	24 V	—	M9NV	M9N	●	●	●	○	○	IC circuit	Relay, PLC
				3-wire (PNP)			F8N	—	●	—	●	○	—		
				2-wire			M9PV	M9P	●	●	●	○	○		
							F8P	—	●	—	●	○	—		
				3-wire (NPN)			M9BV	M9B	●	●	●	○	○		
							F8B	—	●	—	●	○	—		
	Diagnostic indication (2-color indicator)	Grommet	Yes	3-wire (NPN)	24 V	—	M9NV	M9NV	●	●	●	○	○	IC circuit	Relay, PLC
				3-wire (PNP)			M9PW	M9PW	●	●	●	○	○		
				2-wire			M9BWV	M9BW	●	●	●	○	○	—	
							M9NAV**	M9NA**	○	○	●	○	○	IC circuit	
				3-wire (NPN)			M9PAV**	M9PA**	○	○	●	○	○	IC circuit	
							2-wire	M9BAV**	M9BA**	○	○	●	○	○	

\*\* Although it is possible to mount water resistant type auto switches, note that the rotary actuator itself is not of water resistant construction.

\* Lead wire length symbols: 0.5 m ..... Nil (Example) M9NW

1 m ..... M (Example) M9NWM

3 m ..... L (Example) M9NWL

5 m ..... Z (Example) M9NWX

\* Auto switches marked with "O" are made to order specification.

\* Refer to pages 970 and 971 for the details of solid state auto switch with pre-wired connector.

Note 1) When using D-F8□, mount it at a distance of 10 mm or more from magnetic substances such as iron.

\* Auto switches are shipped together, (but not assembled).

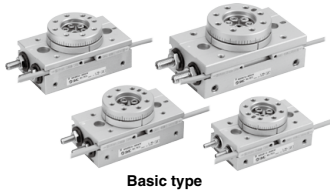

Basic type



High precision type

**Symbol**

**Specifications**

Size	1	2	3	7
Fluid	Air (non-lube)			
Maximum operating pressure	0.7 MPa			
Minimum operating pressure	0.1 MPa			
Ambient and fluid temperature	0 to 60°C (with no freezing)			
Cushion	None		Rubber bumper	
Angle adjustment range	0 to 190°			
Maximum rotation	190°			
Cylinder bore size	ø6	ø8	ø10	ø12
Port size	M3 x 0.5			M5 x 0.8

**Allowable Kinetic Energy and Rotation Time Adjustment Range**

Size	Allowable kinetic energy (J)	Rotation time adjustment range for suitable operation (s/90°)
1	0.001	0.2 to 0.7
2	0.0015	
3	0.002	
7	0.006	0.2 to 1.0

Note) If operated where the kinetic energy exceeds the allowable value, this may cause damage to the internal parts and result in product failure. Please pay special attention to the kinetic energy levels when designing and during operation to avoid exceeding the allowable limit.

**Weight**

Size	1	2	3	7
Basic type	75	105	150	250
High precision type	80	115	165	265

Note) Excluding the weight of auto switches

**Clean Series**

Prevents dispersion of the particles generated inside of the product into the clean room by sucking them out of the vacuum port on the body side.

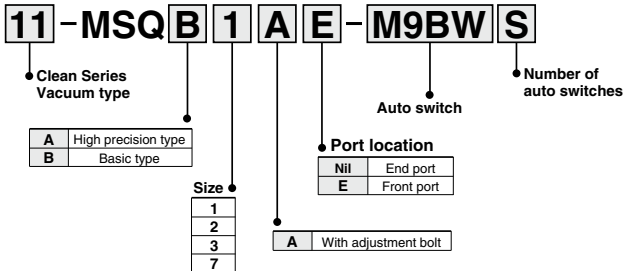
**How to Order**

**Dimensions**

Clean series products do not have a hollow axis.

**Basic type**  
11-MSQB□A

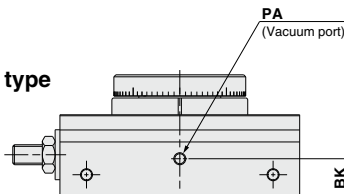
**High precision type**  
11-MSQA□A

**Specifications**

Cleanliness class (ISO class)	Suction flow rate (example)
Class 3 <small>Note 1)</small>	1 L/min (ANR)

11-MSQA is identical to the high precision type and 11-MSQB is identical to the basic type.

Note 1) Please refer to the **Web Catalog** for further details.



Size	BK	PA
1	5.3	M3 x 0.5
2	7.5	M3 x 0.5
3	9.5	M3 x 0.5
7	7	M5 x 0.8

Dimensions other than above are identical to the basic type and the high precision type.

## Rotation Direction and Rotation Angle

- The rotary table turns in the clockwise direction when the A port is pressurized, and in the counter-clockwise direction when the B port is pressurized.
- By adjusting the adjustment bolt, the rotation end can be set within the range shown in the drawing.

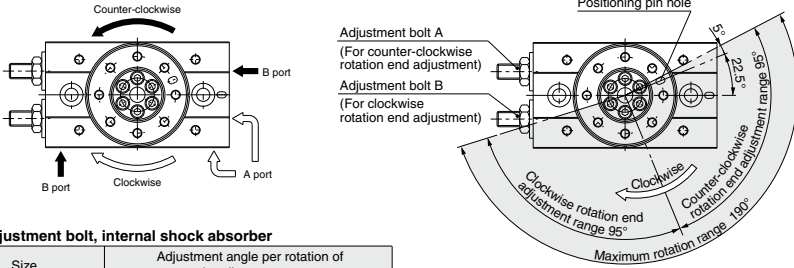

### With adjustment bolt, internal shock absorber

Size	Adjustment angle per rotation of angle adjustment screw
1	8.2°
2	10.0°
3	10.9°
7	10.2°

- Note)
- The drawing shows the rotation range of the positioning pin hole.
  - The pin hole position in the drawing shows the counter-clockwise rotation end when the adjustment bolts A and B are tightened equally and the rotation is adjusted 180°.

## Rotation Range Example

- Various rotation ranges are possible as shown in the drawings below using adjustment bolts A and B. (The drawings also show the rotation ranges of the positioning pin hole.)

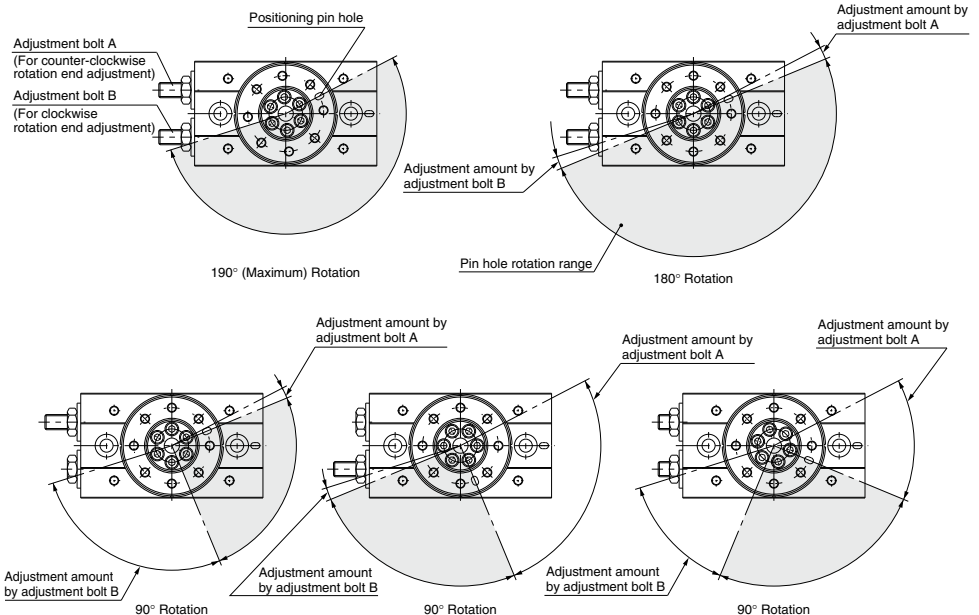

## Construction

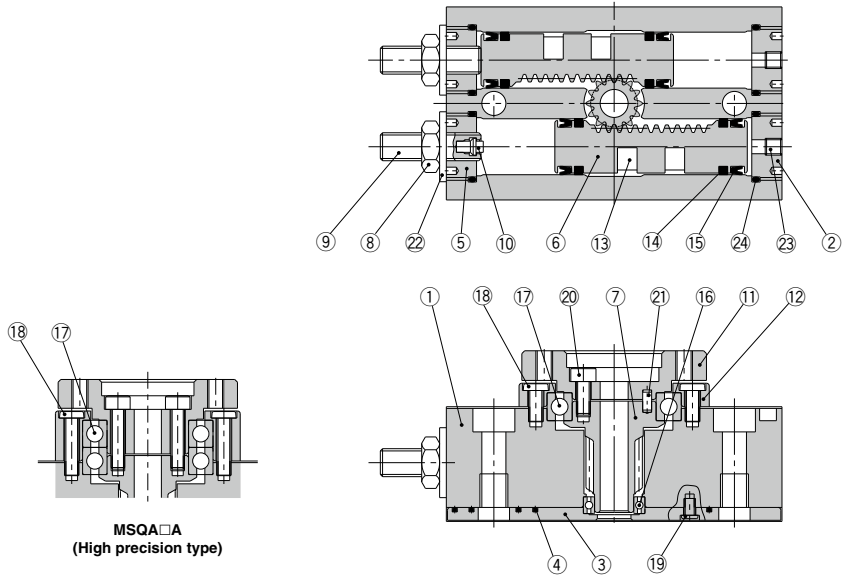

MSQA□A  
(High precision type)

## Component Parts

No.	Description		Material	Note
1	Body		Aluminium alloy	Anodized
2	Cover		Aluminium alloy	Anodized
3	Plate		Aluminium alloy	Chromated
4	Seal		NBR	
5	End cover		Aluminium alloy	Anodized
6	Piston		Stainless steel	
7	Pinion		Chrome molybdenum steel	
8	Hexagon nut		Steel wire	
9	Adjustment bolt		Steel wire	
10	Cushion pad	Size: 3, 7	Rubber material	
11	Table		Aluminium alloy	Anodized
12	Bearing retainer		Aluminium alloy	Anodized
13	Magnet		—	
14	Wear ring		Resin	
15	Piston seal		NBR	
16	Deep groove ball bearing		Bearing steel	
17	Deep groove ball bearing	Basic type	Bearing steel	
	Special bearing	High precision type		
18	Round head Philips screw No.0	Basic type	Steel wire	
	Round head Philips screw			
	Round head Philips screw	High precision type		
19	Round head Philips screw No.0		Steel wire	
20	Hexagon socket head set bolt		Stainless steel	
21	Parallel pin		Carbon steel	
22	Seal washer		NBR	
23	Hexagon socket head set screw		Stainless steel	
24	O-ring		NBR	

\*23 The hexagon socket head set screws are tightened at different positions depending on the position of the connecting port.

\* The component parts cannot be shipped individually.

\* Not able to disassemble. Refer to page 362 for details.



# Rotary Table/Rack & Pinion Type **MSQ Series**

Size: 10, 20, 30, 50, 70, 100, 200

## How to Order

**High Precision Type** MSQ A 10 A - M9BW [ ] [ ]

**Basic Type** MSQ B 10 A - M9BW [ ] [ ]

**Size**

10
20
30
50
70
100
200

**Thread type**

End port type	Size
Nil	M 5
Nil	Rc 1/8
-XF	G 1/8
-XN	NPT 1/8
-XT	NPTF 1/8

\* Side ports are all M5.

**Number of auto switches**

Nil	2 pcs.
S	1 pc.
n	n pcs.

**Auto switch type**

Nil	Without auto switch (built-in magnet)
-----	---------------------------------------

\* Refer to the table below for auto switch types.

**Adjustment Bolt / Shock Absorber**

A	With adjustment bolt
R	With internal shock absorber

### Applicable Auto Switches

Refer to pages 929 to 983 for detailed auto switch specification.

Type	Special function	Electrical entry	Indicator light	Wiring (Output)	Load voltage		Auto switch model		Lead wire length (m)			Pre-wired connector	Applicable load		
					DC	AC	Perpendicular	In-line	0.5 (Nil)	1 (M)	3 (L)		5 (Z)	IC circuit	Relay, PLC
Solid state auto switch	—	Grommet	Yes	3-wire (NPN)	5 V, 12 V	—	M9NV	M9N	●	●	●	○	IC circuit	Relay, PLC	
				3-wire (PNP)			M9PV	M9P	●	●	●	○			
				2-wire	M9BV		M9B	●	●	○	○				
				3-wire (NPN)	M9NWV		M9NW	●	●	●	○				
	Diagnostic indication (2-color indicator)	Grommet	Yes	3-wire (PNP)	5 V, 12 V	—	M9PWV	M9PW	●	●	●	○	IC circuit	Relay, PLC	
				2-wire			M9BWW	M9BW	●	●	●	○			
	Water resistant (2-color indicator)	Grommet	Yes	3-wire (NPN)	5 V, 12 V	—	M9NAV <sup>*1</sup>	M9NA <sup>*1</sup>	○	○	○	○	IC circuit	Relay, PLC	
				3-wire (PNP)			M9PAV <sup>*1</sup>	M9PA <sup>*1</sup>	○	○	●	○			
				2-wire	M9BAV <sup>*1</sup>		M9BA <sup>*1</sup>	○	○	●	○				
				2-wire	M9BAV <sup>*1</sup>		M9BA <sup>*1</sup>	○	○	●	○				
Reed auto switch	—	Grommet	No	3-wire (NPN equiv.)	—	5 V	A96V	A96	●	●	●	○	IC circuit	—	
				2-wire	24 V	12 V	100 V	A93V	A93	●	●	●	○ <sup>*2</sup>	—	Relay, PLC
							100 V or less	A90V	A90	●	●	●	○ <sup>*2</sup>		

\*1 Although it is possible to mount water resistant type auto switches, note that the rotary actuator itself is not of water resistant construction.

\*2 The load voltage used is 24 VDC.

\* Lead wire length symbols: 0.5 m ..... Nil (Example) M9NW  
 1 m ..... M (Example) M9NWM  
 3 m ..... L (Example) M9NWL  
 5 m ..... Z (Example) M9NWZ

\* Auto switches marked with a "○" are produced upon receipt of orders.

\* Refer to the **Web Catalog** for the details of auto switch with pre-wired connector.

\* Auto switches are shipped together, (but not assembled).

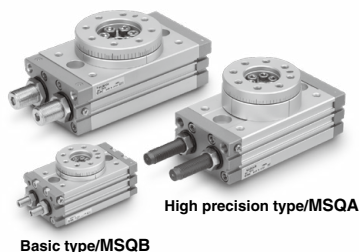

## Symbol



## Specifications

Size	10	20	30	50	70	100	200
<b>Fluid</b>	Air (non-lube)						
<b>Maximum operating pressure</b>	With adjustment bolt	1 MPa					
	With internal shock absorber	0.6 MPa <sup>Note 1)</sup>					
<b>Minimum operating pressure</b>	Basic type	0.1 MPa					
	High precision type	0.2 MPa	0.1 MPa		—		
<b>Ambient and fluid temperature</b>	0 to 60°C (with no freezing)						
<b>Cushion</b>	With adjustment bolt	Rubber bumper					
	With internal shock absorber	Shock absorber					
	Shock absorber model	RBA0805-X692	RBA1006-X692	RBA1411-X692	RBA2015-X821	RBA2725-X821	
<b>Angle adjustment range</b>	0 to 190° <sup>Note 2)</sup>						
<b>Maximum rotation</b>	190°						
<b>Cylinder bore size</b>	ø15	ø18	ø21	ø25	ø28	ø32	ø40
<b>Port size</b>	End ports	M5 x 0.8		Rc 1/8, G 1/8, NPT 1/8			
	Side ports	M5 x 0.8					

Note 1) The maximum operating pressure of the actuator is restricted by the maximum allowable thrust of the shock absorber.

Note 2) Be careful if the rotation angle of a type with internal shock absorber is set below the value in the table below, the piston stroke will be smaller than the shock absorber's effective stroke, resulting in decreased energy absorption ability.

Size	10	20	30	50	70	100	200
Minimum rotation angle that will not allow decrease of energy absorption ability	52°	43°	40°	60°	71°	62°	82°

The service life of the shock absorber may be different from the rotary table body depending on the operating conditions. Refer to Specific Product Precautions for the suitable replacement period.

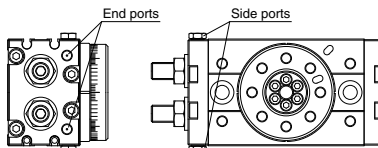

## Allowable Kinetic Energy and Rotation Time Adjustment Range

Size	Allowable kinetic energy (J) <sup>Note 1)</sup>		Rotation time adjustment range for stable operation (s/90°) <sup>Note 2)</sup>	
	With adjustment bolt	With internal shock absorber	With adjustment bolt	With internal shock absorber
10	0.007	0.039	0.2 to 1.0	0.2 to 0.7
20	0.025	0.116		
30	0.048	0.116		
50	0.081	0.294	0.2 to 1.5	0.2 to 1.0
70	0.240	1.100		
100	0.320	1.600		
200	0.560	2.900	0.2 to 2.0	0.2 to 2.5

Note 1) If operated where the kinetic energy exceeds the allowable value, this may cause damage to the internal parts and result in product failure. Please pay special attention to the kinetic energy levels when designing and during operation to avoid exceeding the allowable limit.

Note 2) When the rotation time of the type with an internal absorber is set longer than the time shown in the table above, energy absorption of the shock absorber greatly decreases.

## Weight

Size		10	20	30	50	70	100	200
Basic type	With adjustment bolt	500	940	1230	1990	2880	4090	7580
	With internal shock absorber	510	940	1230	2010	2890	4100	7650
High precision type	With adjustment bolt	530	1040	1350	2150	—		
	With internal shock absorber	540	1040	1350	2170	—		

Note) Values above do not include auto switch weight.

## Rotation Direction and Rotation Angle

- The rotary table turns in the clockwise direction where the A port is pressurized, and in the counter-clockwise direction when the B port is pressurized.
- By adjusting the adjustment bolt, the rotation end can be set within the ranges shown in the drawing.
- The rotation angle can also be set on a type with internal absorber.

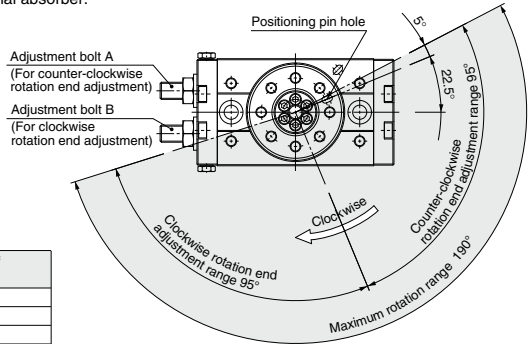
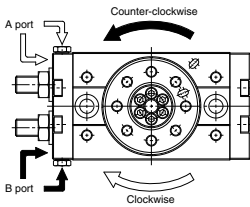

### With adjustment bolt, internal shock absorber

Size	Adjustment angle per rotation of angle adjustment screw
10	10.2°
20	7.2°
30	6.5°
50	8.2°
70	7.0°
100	6.1°
200	4.9°

- Note • The drawing shows the rotation range of the positioning pin hole.  
 • The pin hole position in the drawing shows the counter-clockwise rotation end when the adjustment bolts A and B are tightened equally and the rotation is adjusted 180°.

## Rotation Range Example

- Various rotation ranges are possible as shown in the drawings below using adjustment bolts A and B. (The drawings also show the rotation ranges of the positioning pin hole.)
- The rotation angle can also be set on a type with inertial absorber.

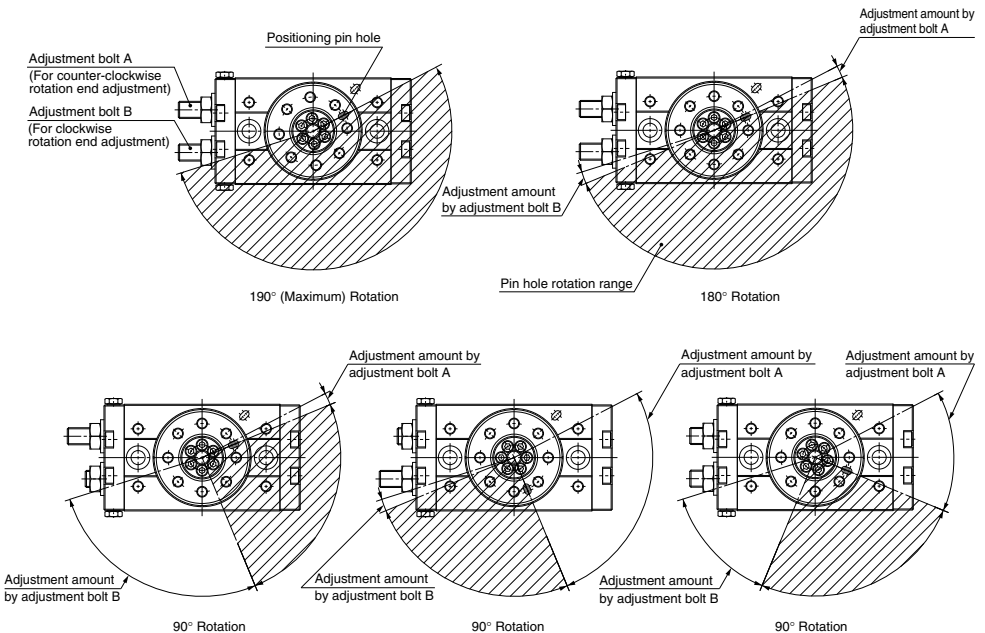

# MSQ Series

## Clean Series

Prevents dispersion of the particles generated inside of the product into the clean room by sucking them out of the vacuum port on the body side.

### How to Order

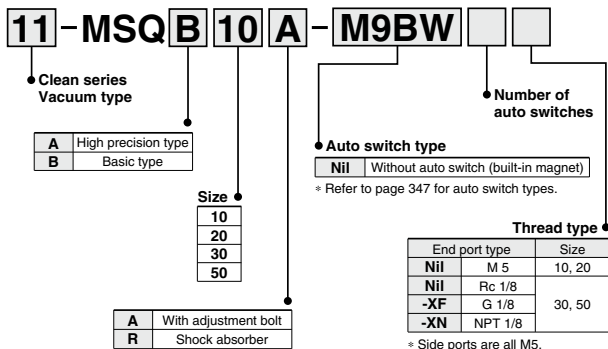

### Specifications

Cleanliness class (ISO class)	Suction flow rate (example)
Class 3 (Note 1)	1 L/min (ANR)

11-MSQA is identical to the high precision type and 11-MSQB is identical to the basic type.

Note 1) Please refer to the [Web Catalog](#) for further details.

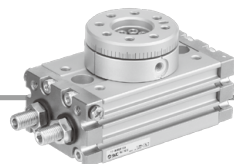

## Dimensions

Clean series products do not have a hollow axis.

### Basic type

11-MSQB□A  
11-MSQB□R

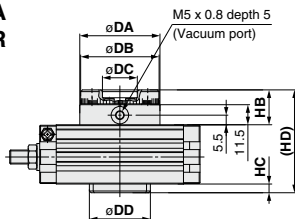

Size	DA(h9)	DB(h9)	DC(H9)	DD(h9)	HB	HC	HD
10	46	45	20	35	20	5	59
20	61	60	28	40	22	6	65
30	67	65	32	48	22	6	68
50	77	75	35	54	24	7	77

(mm)

Dimensions other than above are identical to the basic type.

### High precision type

11-MSQA□A  
11-MSQA□R

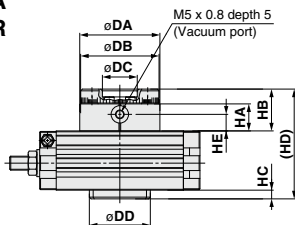

Size	DA(h8)	DB(h8)	DC(H8)	DD(h8)	HA	HB	HC	HD	HE
10	46	45	20	35	15.5	24	5	63	9.5
20	61	60	28	40	19.5	30	6	73	13.5
30	67	65	32	48	19.5	30	6	76	13.5
50	77	75	35	54	21.5	34	7	87	15.5

(mm)

Dimensions other than above are identical to the high precision type.







# Rotary Table/Rack & Pinion Type

# MSQ Series

## With External Shock Absorber

### Size: 10, 20, 30, 50

### How to Order

**MSQ B 10 L 2** - **M9BW**

**A** High precision type  
**B** Basic type

**Size**  
10  
20  
30  
50

**Shock absorber type**  
**L** Shock absorber for low energy  
**H** Shock absorber for high energy

**Port location/Rotation**

2	Standard type	180°
3	Standard type	90°
4	Symmetric type	180°
5	Symmetric type	90°

Refer to the table to the right.

**Number of auto switch**

Nil	2 pcs.
S	1 pc.
n	n pcs.

**Auto switch type**

Nil	Without auto switch (Built-in magnet)
-----	---------------------------------------

**Port type**  
Refer to page 360 for the Made to Order details.

End port type	Size
Nil	M 5 Rc 1/8
-XF	G 1/8
-XN	NPT 1/8

\* Side ports are all M5.

**Auto switch type**  
Nil Without auto switch (Built-in magnet)

\*Refer to the table below for auto switch types.

### Port location/Rotation

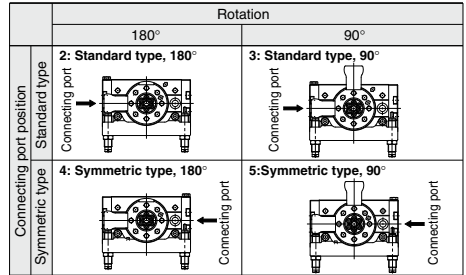

### Applicable Auto Switches

Refer to pages 929 to 983 for detailed auto switch specification.

Type	Special function	Electrical entry	Indicator light	Wiring (Output)	Load voltage		Auto switch model		Lead wire length (m)					Pre-wired connector	Applicable load	
					DC	AC	Perpendicular	In-line	0.5 (Nil)	1 (M)	3 (L)	5 (Z)				
Solid state auto switch	Diagnostic indication (2-color indicator)	Grommet	Yes	3-wire (NPN)	24 V	5 V, 12 V	—	M9NV	M9N	●	●	●	○	○	IC circuit	
				3-wire (PNP)				M9PV	M9P	●	●	●	○	○		
				2-wire	M9BV	M9B	●	●	●	○	○	—				
				3-wire (NPN)	M9NWV	M9NW	●	●	●	○	○	IC circuit				
	Water resistant (2-color indicator)	Grommet	No	3-wire (PNP)	24 V	12 V	—	M9PWV	M9PW	●	●	●	○	○	—	
				2-wire				M9B WV	M9B W	●	●	●	○	○		
				3-wire (NPN)	M9NAV <sup>*1</sup>	M9NA <sup>*1</sup>	○	○	○	○	○	IC circuit				
				2-wire	M9PAV <sup>*1</sup>	M9PA <sup>*1</sup>	○	○	●	○	○	—				
Reed auto switch	—	Grommet	Yes	3-wire (NPN equiv.)	24 V	12 V	—	A96V	A96	●	●	●	—	—	IC circuit	—
				2-wire				A93V <sup>*2</sup>	A93	●	●	●	—	—	—	
Reed auto switch	—	Grommet	No	2-wire	24 V	12 V	—	A90V	A90	●	●	—	—	—	—	IC circuit
				2-wire				M9BAV <sup>*1</sup>	M9BA <sup>*1</sup>	○	○	●	○	○	—	—

\*1 Although it is possible to mount water resistant type auto switches, note that the rotary actuator itself is not of water resistant construction.  
\*2 1 m type lead wire is only applicable to D-A93.

\* Lead wire length symbols: 0.5 m ..... Nil (Example) M9NV  
1 m ..... M (Example) M9NWM  
3 m ..... L (Example) M9NWL  
5 m ..... Z (Example) M9NWZ

\* Auto switches marked with a "○" are produced upon receipt of orders.

\* Refer to pages 970 and 971 for the details of solid state auto switch with pre-wired connector.

\* Auto switches are shipped together, (but not assembled).

## Specifications



**Symbol**



Size	10	20	30	50
<b>Fluid</b>	Air (non-lube)			
<b>Maximum operating pressure</b>	1 MPa			
<b>Minimum operating pressure</b>	0.2 MPa			
<b>Ambient and fluid temperature</b>	0 to 60°C (with no freezing)			
<b>Cushion</b>	Shock absorber			
<b>Shock absorber type</b>	For low energy	RB0805	RB1006	RB1411
	For high energy	RB0806	RB1007	RB1412
<b>Rotation</b>	90°, 180°			
<b>Angle adjusting range</b>	Each rotation end ±3°			
<b>Cylinder bore size</b>	ø15	ø18	ø21	ø25
<b>Port size</b>	<b>End ports</b>	M5 x 0.8		Rc 1/8, G 1/8, NPT 1/8
	<b>Side ports</b>	M5 x 0.8		

The service life of the shock absorber may be different from the rotary table body depending on the operating conditions. Refer to Specific Product Precautions for the suitable replacement period.

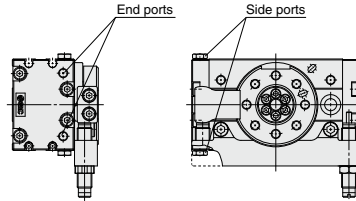

**Made to Order**  
(Refer to page 360 for details)

Symbol	Specifications/Description
<b>-X232</b>	With external adjustment bolt

## Allowable Kinetic Energy and Rotation Time Adjustment Range

Size	Allowable kinetic energy (J) <sup>Note 1)</sup>		Rotation time adjustment range for stable operation (s/90°) <sup>Note 2)</sup>
	Shock absorber for low energy	Shock absorber for high energy	
<b>10</b>	0.161	0.231	0.2 to 1.0
<b>20</b>	0.574	1.060	
<b>30</b>	0.805	1.210	
<b>50</b>	1.310	1.820	

Note 1) If operated where the kinetic energy exceeds the allowable value, this may cause damage to the internal parts and result in product failure. Please pay special attention to the kinetic energy levels when designing and during operation to avoid exceeding the allowable limit.

Note 2) Values above indicate the time between the start of rotation and the deceleration caused by the shock absorber. Although the time required by the rotary table to reach the rotation end after deceleration differs depending on the operating conditions (inertial moment of the load, rotation speed and operating pressure), approximately 0.2 to 2 seconds are required. The range of angles within which the shock absorber operates is between the rotation end and the values shown below.

Size	10	20	30	50
For low energy	7.1°	6.9°	6.2°	9.6°
For high energy	8.6°	8.0°	7.3°	10.5°

## Weight

		10	20	30	50
Basic type	90° specification	600	1150	1460	2390
	180° specification	570	1090	1390	2280
High precision type <sup>a</sup>	90° specification	670	1340	1690	2720
	180° specification	640	1290	1620	2600

Note) Values above do not include auto switch weight.

# MSQ Series

## Rotation Direction and Rotation Angle

- The rotary table turns in the clockwise direction where the A port is pressurized, and in the counter-clockwise direction when the B port is pressurized.
- By adjusting the shock absorber, the rotation end can be set within the ranges shown in the drawing.

### Standard type

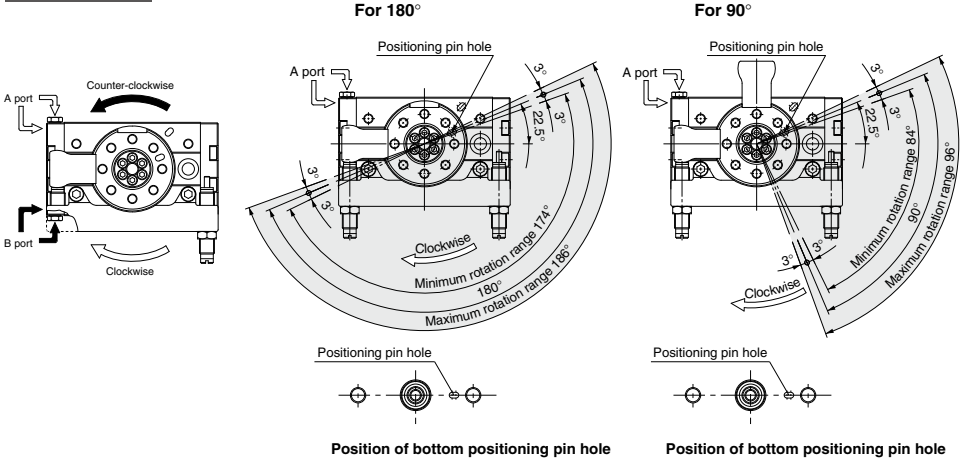

### Symmetric type

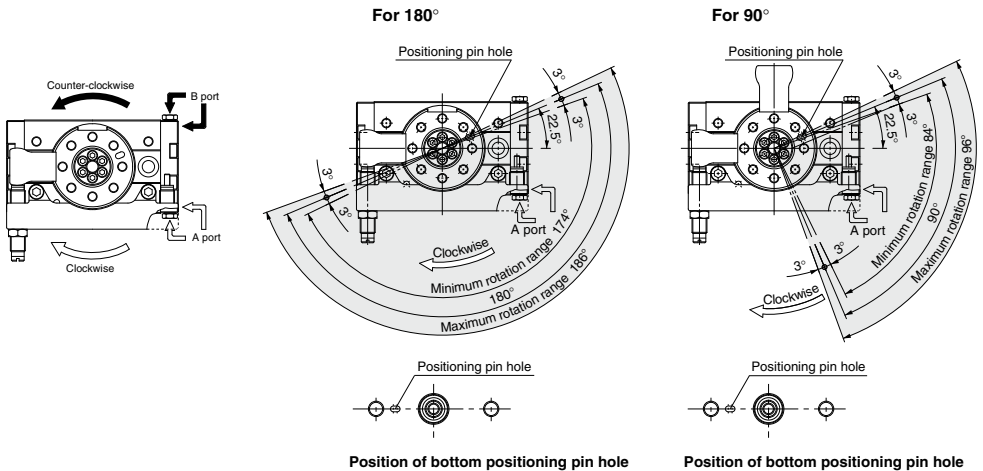

### With external shock absorber

Size	Adjustment angle per rotation of angle adjustment screw
10	1.4°
20	1.2°
30	1.1°
50	1.3°

Note) · The drawings show the rotation range for the top positioning pin hole of the table.

- The pin hole position in the drawing shows the counter-clockwise rotation end when the shock absorbers are tightened equally and the rotation is adjusted to 180° and 90°.

## Construction

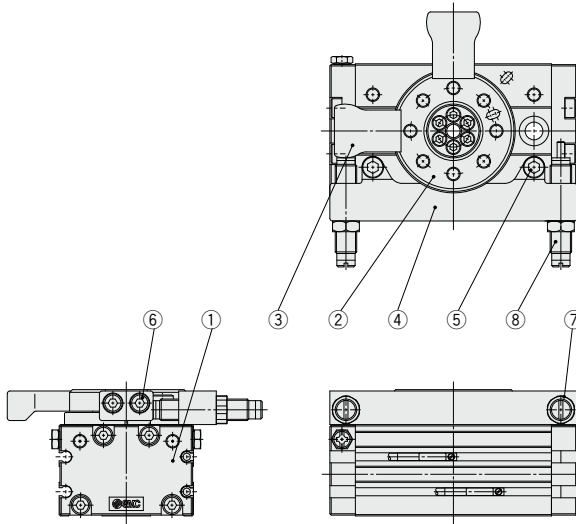

### Component parts

No.	Description	Material	Note
1	End cover	Aluminium alloy	Painted
2	Table	Aluminium alloy	Anodized
3	Arm	Chrome molybdenum steel	Nickel plated
4	Shock absorber holder	Aluminium alloy	Anodized
5	Hexagon socket head set bolt	Stainless steel	
6	Hexagon socket head set bolt	Stainless steel	
7	Hexagon nut	Steel wire	
8	Shock absorber	—	

\* The component parts cannot be shipped individually.

### Replacement parts

Description	Kit no.				Note
	10	20	30	50	
Seal kit	P523010-6	P523020-6	P523030-6	P523040-6	Seal washer ⑦ is excluded from the kit contents described on page 351.

\* The MSQA (High-precision type) cannot be disassembled. Refer to page 362 for details.

A grease pack (10 g) is included. When only a grease pack is needed, order with the following part number.

**Grease pack part no: GR-S-010** (10 g)

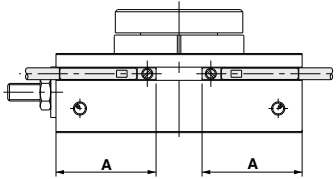

**Proper Auto Switch Mounting Position at Rotation End**
**• Size: 1 to 7**

When D-M9 is used

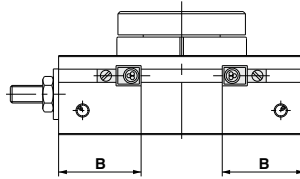

When D-F8 is used

Size	Rotation	Solid state auto switch					
		D-M9□(V), D-M9□W(V)			D-F8□		
		A	Operating angle $\theta$ m	Hysteresis angle	B	Operating angle $\theta$ m	Hysteresis angle
1	190°	20.9	49°	10°	16.9	20°	10°
2	190°	22.8	50°	10°	18.8	20°	10°
3	190°	24.4	47°	10°	20.4	15°	10°
7	190°	28.7	31°	10°	24.7	15°	10°

Operating angle  $\theta$  m: Value of the operating range Lm of a single auto switch converted to an axial rotation angle.

Hysteresis angle : Value of auto switch hysteresis converted to an angle.

Note) Since the above values are only provided as a guideline, they are not guaranteed.

In the actual setting, adjust them after confirming the auto switch operating condition.

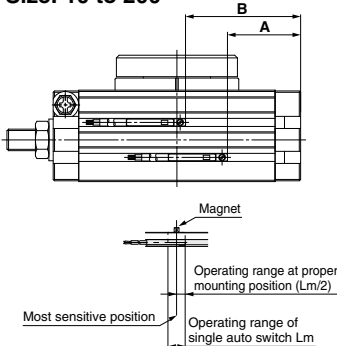
**• Size: 10 to 200**

Size	Rotation	Solid state auto switch				Reed auto switch			
		D-M9□(V), D-M9□W(V)				D-A9□, D-A9□V			
		A	B	Operating angle $\theta$ m	Hysteresis angle	A	B	Operating angle $\theta$ m	Hysteresis angle
10	190°	31	49	37°	5°	27	45	53°	10°
20	190°	39	66	33°	5°	35	62	50°	10°
30	190°	43	72	29°	5°	39	68	43°	10°
50	190°	53	87	22°	5°	49	83	33°	10°
70	190°	58	99	21°	5°	54	95	30°	10°
100	190°	65	112	18°	5°	61	108	27°	10°
200	190°	85	143	15°	5°	81	139	21°	10°

Operating angle  $\theta$  m: Value of the operating range Lm of a single auto switch converted to an axial rotation angle.

Hysteresis angle : Value of auto switch hysteresis converted to an angle.

Note) Since the above values are only provided as a guideline, they are not guaranteed.

In the actual setting, adjust them after confirming the auto switch operating condition.

# MSQ Series

# Made to Order

Please contact SMC for detailed specifications, lead times and prices.



## 1 With External Stopper

Symbol  
**-X232**

By reducing the effective stroke of the shock absorber, the absorption time will be reduced, enabling the cycle time to be improved.

### How to Order

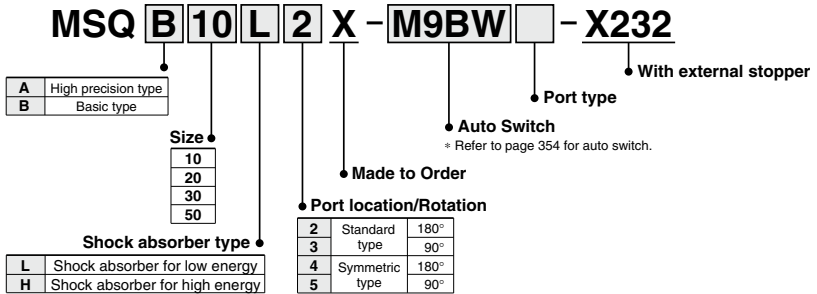

### Specifications

Size	Allowable kinetic energy (J)	
	Shock absorber for low energy	Shock absorber for high energy
10	0.161	0.231
20	0.574	1.060
30	0.805	1.210
50	1.310	1.820

- Note 1) The allowable kinetic energy indicated in the table is the value for the case where the full stroke of the shock absorber is used. Note that if the effective stroke of the shock absorber is shortened using the hexagon socket head set screw, the allowable energy will be lower than the value in the table.
- Note 2) If you wish to adjust the stroke of the shock absorber in order to reduce the cycle time, first set the shock absorber to the position where the shock absorber is to be used in the full stroke, then while observing the operating condition of the product, gradually adjust the stroke in the direction such that the effective stroke decreases.
- Note 3) The shock absorber is a consumable part. If there are signs, such as bounding of the shock absorber at the motion end point, that the energy absorption performance of the shock absorber has deteriorated, readjust the position of the shock absorber so as to increase its effective stroke. If bounding still occurs even when the full stroke is used, it is necessary to replace the shock absorber with a new one.

### Dimensions

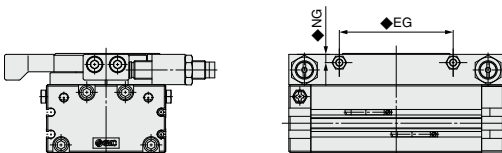
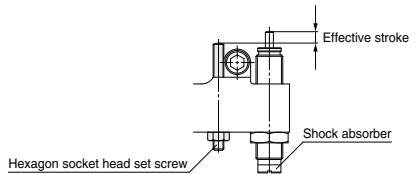
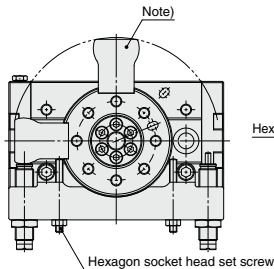
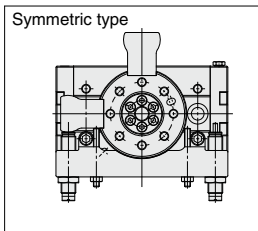

Size	(mm)	
	EG	NG
10	47.4	4.5
20	62	4.5
30	67.6	4.8
50	80	7

Note) This part is not available with 180° specification.

\* Dimensions other than the above are the same as standard.



# MSQ Series

## Specific Product Precautions 1

Be sure to read this before handling the products. For safety instructions as well as rotary actuator and auto switch precautions, refer to the "Handling Precautions for SMC Products" and the "Operation Manual" of each product on the SMC website: <https://www.smcworld.com>

### Speed Adjustment

#### ⚠ Warning

1. Perform speed adjustment gradually from the low speed side.

Speed adjustment from the high speed side can cause product damage leading to human injury and damage to equipment and machinery.

#### ⚠ Caution

1. When operating at high speed with a large load weight, a large amount of energy is applied to the actuator and can cause damage.

Refer to the model selection on page 32 to find the proper operating time.

2. Do not machine the fixed orifice of the port to enlarge its size. If the fixed orifice size is enlarged, the actuator operating speed and impact force will increase and cause damage.

### Lubrication

#### ⚠ Caution

1. Use the product without lubrication.

This product is lubricated with grease at the factory, and further lubrication will result in a failure to meet the product's specifications.

### Rotation Adjustment

#### ⚠ Caution

1. As a standard feature, the rotary table is equipped with a rotation adjustment screw (adjustment bolt or shock absorber) that can be used to adjust the rotation. The table below shows the rotation adjustment per single rotation of the rotation adjustment screw.

Please refer to following pages for the rotation direction, rotation angle and rotation angle range.

MSQ size1 to 7 → page 344

MSQ size10 to 200 → page 349

MSQ with external shock absorber → page 356

#### With adjustment bolt, With external shock absorber

Size	Rotation adjustment per single rotation of rotation adjustment screw
1	8.2°
2	10.0°
3	10.9°
7	10.2°
10	10.2°
20	7.2°
30	6.5°
50	8.2°
70	7.0°
100	6.1°
200	4.9°

#### With external shock absorber

Size	Rotation adjustment per single rotation of rotation adjustment screw
10	1.4°
20	1.2°
30	1.1°
50	1.3°

The rotation adjustment range for the external shock absorber is  $\pm 3^\circ$  at each rotation end. When adjusted beyond this range, note that the shock absorber's durability may decrease.

### Rotation Adjustment

#### ⚠ Caution

2. MSQ Series is equipped with a rubber bumper or shock absorber. Therefore, perform rotation adjustment in the pressurized condition (minimum operation pressure: 0.1 MPa or more for adjustment bolt and internal shock absorber types, and 0.2 MPa or more for external shock absorber type.)

### Shock Absorber

#### ⚠ Caution

1. Refer to the table below for tightening torques of the shock absorber setting nut.

Size	10	20	30	50	70	100	200
Tightening torque N·m	1.67	3.14	10.8	23.5	62.8		

2. Never rotate the bottom screw of the shock absorber. (It is not an adjustment screw.) This may cause oil leakage.

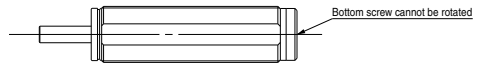

3. When rotation of the rotary table with internal shock absorber is set at a value smaller than the table below, the piston stroke becomes smaller than the shock absorber's effective stroke and energy absorption capacity decreases.

Size	10	20	30	50	70	100	200
Minimum rotation without energy absorption capacity decrease	52°	43°	40°	60°	71°	62°	82°

4. Products with shock absorber are not designed to smooth stop but to absorb the kinetic energy of the load. If the load has to be stopped smoothly, a shock absorber of the optimum size meeting the operating conditions must be installed external to the equipment.

5. Shock absorbers are consumable parts. When a decrease in energy absorption capacity is noticed, it must be replaced.

#### With internal shock absorber

Size	Shock absorber model
10	RBA0805-X692
20	RBA1006-X692
30	
50	RBA1411-X692
70	
100	RBA2015-X821
200	RBA2725-X821

#### With external shock absorber

Size	Type	Shock absorber model
10	For low energy	RB0805
	For high energy	RB0806
20	For low energy	RB1006
	For high energy	RB1007
30	For low energy	RB1006
	For high energy	RB1007
50	For low energy	RB1411
	For high energy	RB1412



# MSQ Series

## Specific Product Precautions 2

Be sure to read this before handling the products. For safety instructions as well as rotary actuator and auto switch precautions, refer to the “Handling Precautions for SMC Products” and the “Operation Manual” of each product on the SMC website: <https://www.smcworld.com>

### Service Life and Replacement Period of Shock Absorber

#### Caution

##### 1. Allowable operation time under the specifications set in this catalog is 1 million.

(Note) Specified service life (suitable replacement period) is the value at room temperature (20 to 25°C). The period may vary depending on the temperature and other conditions. In some cases the absorber may need to be replaced before the allowable operation time above.

### External Shock Absorber

#### Caution

Abrasion powder may be generated from the part where the shock absorber collides with the arm. Do not use the product in a place where abrasion powder may affect adversely.

### Speed Controller and Fittings

#### Caution

Size 1, 2, and 3 use M3 x 0.5 piping ports. When connecting a speed controller or fittings directly, use the following series.

- Speed controller
  - AS12□1F/Elbow type
  - AS13□1F/Universal type
- One-touch fitting
  - One-touch miniature fittings KQ2 series
- Miniature fittings M3 series

### Auto switch

#### Caution

In case of sizes 1, 2, 3 and 7, when 2 pieces of auto switches are installed in one switch groove, the minimum detectable rotation angles are as follows.

Size	Minimum detectable rotation
1	25°
2	25°
3	20°
7	20°

### Maintenance and Inspection

#### Caution

Since sizes 1, 2, 3 and 7 require special tools, they cannot be disassembled.

Since sizes 10, 20, 30 and 50 have the table press fit into an angular type bearing, they cannot be disassembled.