

Rotary Clamp Cylinders

Double guide type is added!

Double guide type
Series MK2T
ø20, ø25, ø32, ø40, ø50, ø63



Heavy duty type
Series MK2
ø20, ø25, ø32, ø40
ø50, ø63



Standard
Series MK

ø12, ø16, ø20, ø25
ø32, ø40, ø50, ø63



Improved non-rotating accuracy and rotation angle!

Rotation mechanism uses 2 guide rollers.

Non-rotating accuracy: $\pm 0.9^\circ \Rightarrow \pm 0.5^\circ$
(Clamp part) * Values for ø32, ø40. Comparison with our MK2 series

Rotation angle: $90^\circ \pm 10^\circ \Rightarrow 90^\circ \pm 5^\circ$

3 times the allowable moment of inertia

ø32, ø40

* Comparison with our MK2 series

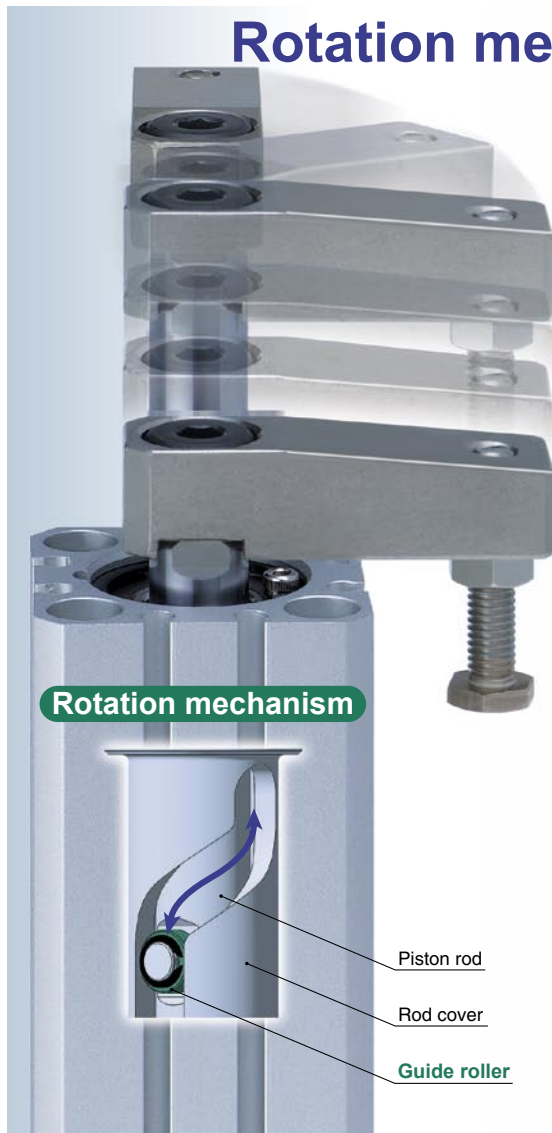
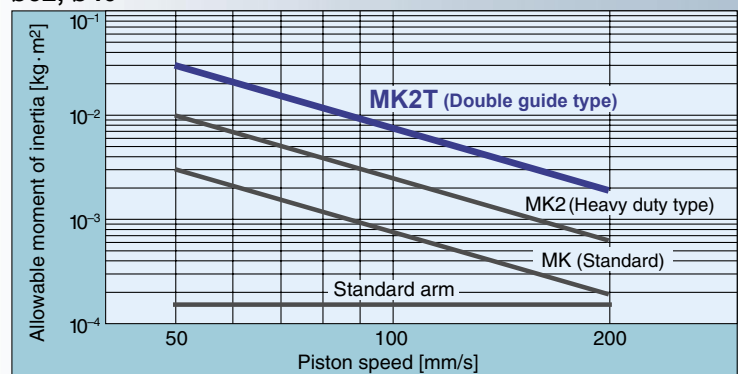

Horizontal mounting possible

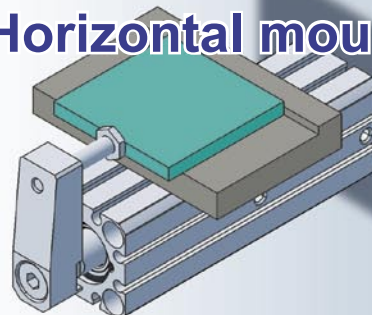

- Interchangeable mounting pitch (MK, MK2)
- Small auto switches mountable on 4 surfaces * Bore size ø20, ø25

Series MK2T/MK2/MK



CAT.EUS20-67F-UK

Series MK/MK2/MK2T Model Selection

Item	Series	MK	MK2	MK2T
Max. piston speed ^{Note)} [mm/s]	ø12, ø16	200	—	—
	ø20, ø25	180	200	
	ø32 to ø63	200		
Non-rotating accuracy (Clamp part)	ø12	±1.4°	—	—
	ø16	±1.2°	—	—
	ø20, ø25	±1.2°		±1.0°
	ø32, ø40	±0.9°		±0.5°
	ø50, ø63	±0.7°		±0.5°
Rotation angle		90°±10°		90°±5°
Horizontal mounting		Not allowed		Allowed

Note) "Maximum piston speed" indicates the maximum speed possible when employing a standard arm.

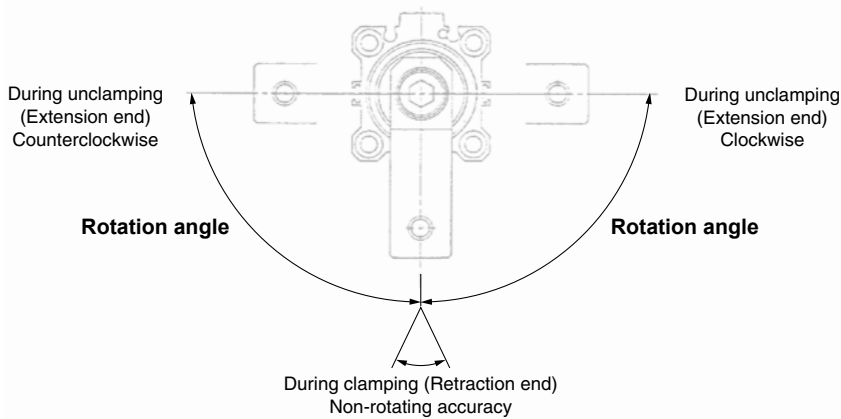

[Actual calculation example]

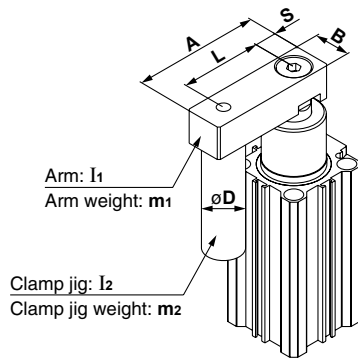

Example) Find the moment of inertia of the arm.

$$I_1 = m_1 \cdot \frac{A^2 + B^2}{12} + m_1 \cdot \left[\frac{A}{2} - S \right]^2$$

Find the moment of inertia of the clamp jig.

$$I_2 = m_2 \cdot \frac{D^2}{8} + m_2 \cdot L^2$$

(Calculation example) Cylinder bore size ø32

$A = 0.07$ m, $B = 0.02$ m, $S = 0.012$ m, $L = 0.045$ m, $D = 0.02$ m

$m_1 = 0.16$ kg, $m_2 = 0.15$ kg

$$I_1 = 0.16 \times \frac{0.07^2 + 0.02^2}{12} + 0.16 \times \left[\frac{0.07}{2} - 0.012 \right]^2 = 1.6 \times 10^{-4} \text{ kg} \cdot \text{m}^2$$

$$I_2 = 0.15 \times \frac{0.02^2}{8} + 0.15 \times 0.045^2 = 3.0 \times 10^{-4} \text{ kg} \cdot \text{m}^2$$

Find the actual moment of inertia.

$$I = I_1 + I_2 = (1.6 + 3.0) \times 10^{-4} = 4.6 \times 10^{-4} \text{ kg} \cdot \text{m}^2$$

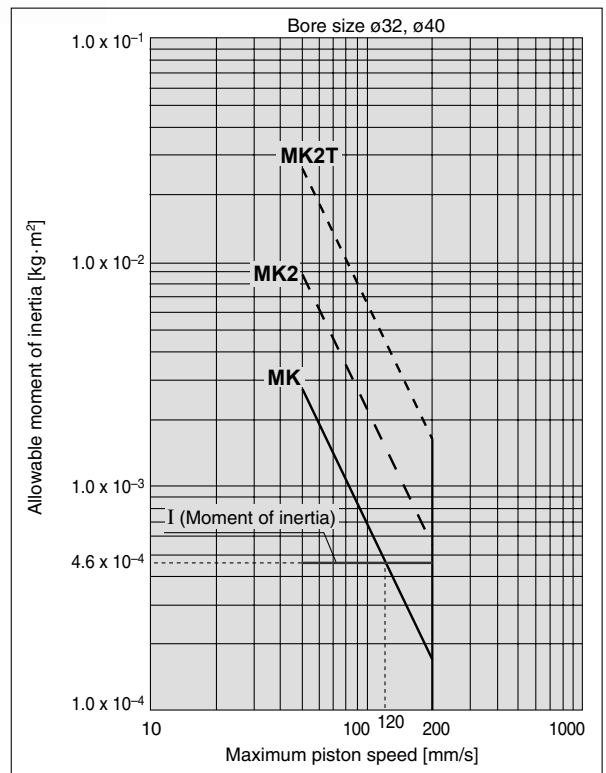

Calculation Example (ø32, clamp stroke 10 mm)

Series	Max. piston speed	Average piston speed ^{Note 1)}	Stroke total	Stroke time ^{Note 2)}
MK	120 mm/s	75 mm/s	25 mm	0.35 sec.
MK2	200 mm/s	125 mm/s		0.2 sec.

Note 1) Average piston speed = Maximum piston speed ÷ 1.6.

Note 2) Please use the stroke speeds indicated above.

Moment of Inertia

ø12, ø16

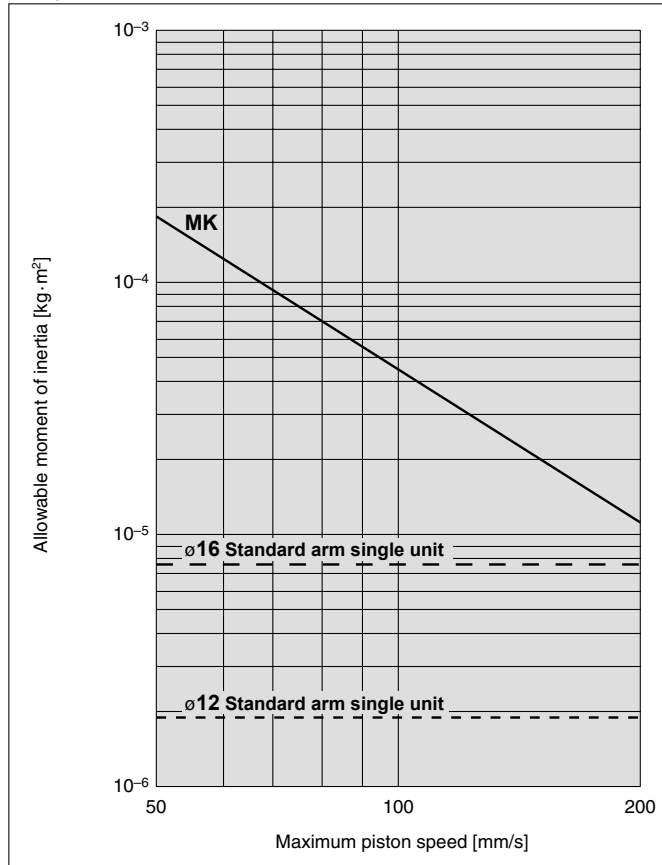

ø20, ø25

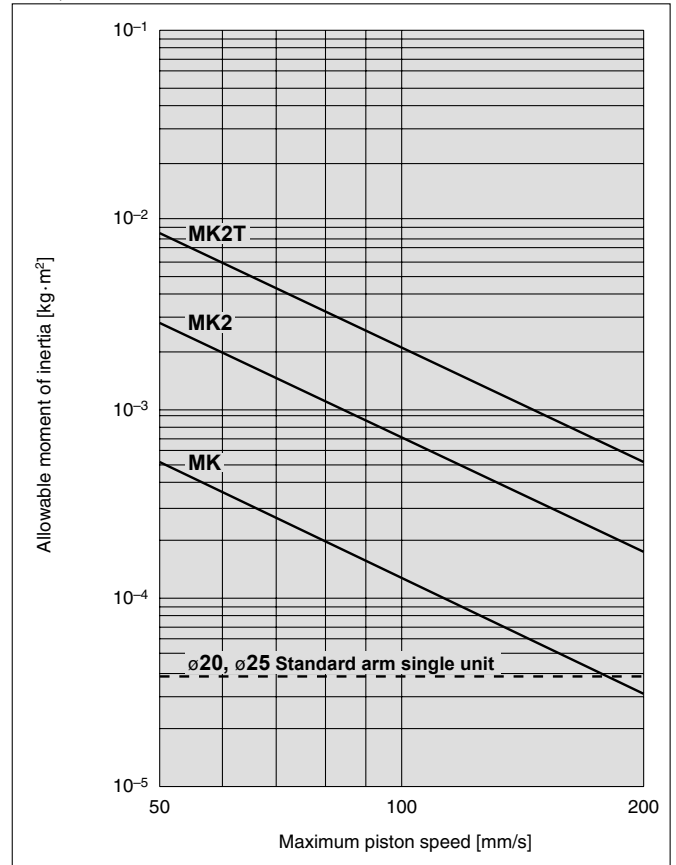

ø32, ø40

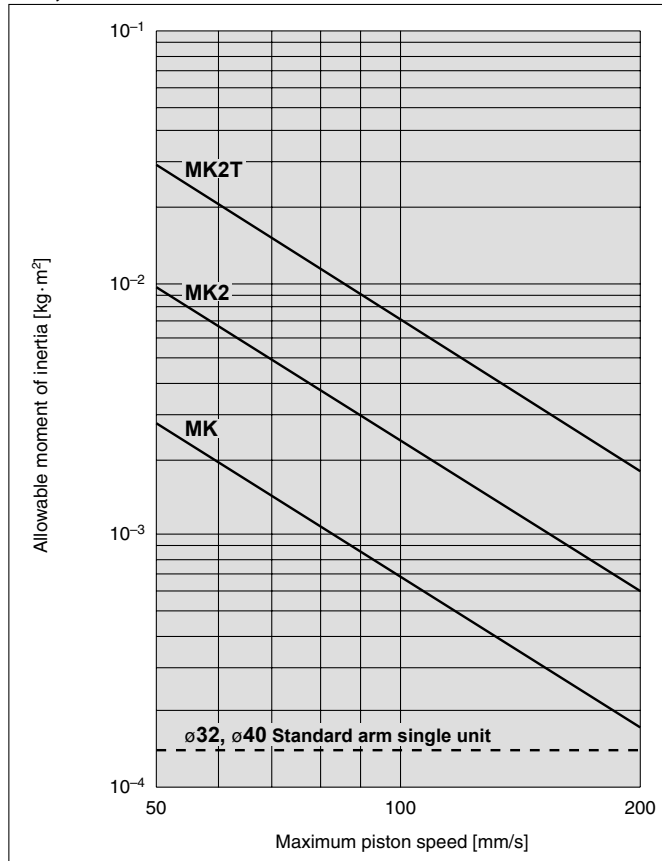

ø50, ø63

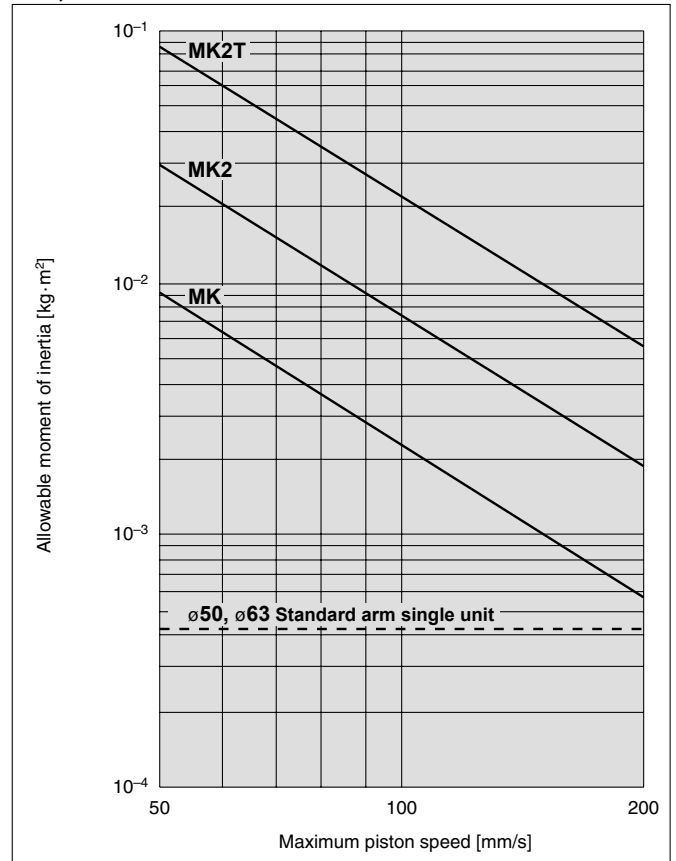

(Note) Maximum piston speed is equivalent to approximately 1.6x the average piston speed. (Rough indication)

Rotary Clamp Cylinder: Standard

Series MK

ø12, ø16, ø20, ø25, ø32, ø40, ø50, ø63

How to Order

MK A 20 - 10 R F - M9BW -

Rotary clamp cylinder
Standard

Mounting bracket

Symbol	Mounting	Applicable bore size (mm)
B	Through-hole/Both ends tapped common (Standard)	ø12, ø16
A	Both ends tapped	ø20 to ø63
B	Through-hole	
G	Head end flange	

* Head end flange is equipped with a boss mounting. Be sure to specify body option "F".
* Mounting bracket is included, (but not assembled).

Bore size

12	12 mm	32	32 mm
16	16 mm	40	40 mm
20	20 mm	50	50 mm
25	25 mm	63	63 mm

Port thread type

	M thread	ø12 to ø25
—	Rc	ø32 to ø63
TN	NPT	
TF	G	

Clamp stroke

Symbol	Clamp stroke	Applicable bore size
10	10 mm	ø12 to ø40
20	20 mm	ø12 to ø63
50	50 mm	ø50 to ø63

Number of auto switches

—	2 pcs.
S	1 pc.

Auto switch type

—	Without auto switch (Built-in magnet)
---	---------------------------------------

* For applicable auto switch models, refer to the table below.

Body option

—	Standard (Female thread)
M	Rod end width across flats*
F	With boss on head end*
N	With arm

* Regarding body option manufacturable range, refer to the table below.

Body Option Manufacturable Range

Bore size	—	M	F	N	MF	FN
ø12, ø16	●	—	—	●	—	—
ø20 to ø63	●	●	●	●	●	●

* Arms are assembled at the time of shipment.

Rotary direction (Unclamp → Clamp)

R	Clockwise
L	Counterclockwise

Made to Order
(Refer to page 2 and 40.)

Applicable Auto Switches/Refer to page 29 through 39 for further information on auto switches.

Type	Special function	Electrical entry	Indicator light	Wiring (Output)	Load voltage		Auto switch model		Lead wire length (m)					Pre-wired connector	Applicable load					
					DC	AC	Perpendicular ø12, ø16 ø20 to ø63	In-line ø12, ø16 ø20 to ø63	0.5 (—)	1 (M)	3 (L)	5 (Z)	None (N)							
Solid state switch	—	Grommet	No	3-wire (NPN)	24 V	5 V, 12 V	—	M9NV	M9N	●	—	●	○	—	○	IC circuit				
				3-wire (PNP)				M9PV	M9P	●	—	●	○	—	○					
		2-wire	M9BV	M9B				●	—	●	○	—	○							
		—	J79C	—				●	—	●	●	—	—							
	Diagnostic indication (2-colour indication)	Grommet	Yes	3-wire (NPN)	24 V	5 V, 12 V	—	M9NWV	M9NW	●	●	●	○	—	○	IC circuit				
				3-wire (PNP)				M9P WV	M9P W	●	●	●	○	—	○					
				2-wire				M9B WV	M9B W	●	●	●	○	—	○					
				3-wire (NPN)				M9NAV	M9NA	○	○	●	○	—	○					
				3-wire (PNP)				M9PAV	M9PA	○	○	●	○	—	○					
				2-wire				M9BAV	M9BA	○	○	●	○	—	○					
Diagnostic output (2-colour indication)	Grommet	No	4-wire	24 V	5 V, 12 V	—	—	F79F	●	—	●	○	—	○	IC circuit					
Magnetic field resistant (2-colour indication)			2-wire (No polarity)				—	P4DW	—	—	●	●	—	○						
Reed switch	—	Grommet	Yes	3-wire (NPN equivalent)	24 V	5 V	—	A96V	A96	●	—	●	—	—	IC circuit					
				—				A72	—	A72H	●	—	●	—		—				
				12 V				A93V	—	A93	●	—	●	—		—				
		Connector	No	2-wire				24 V	5 V, 12 V	100 V or less	—	A90V	A90	●	—	●	—	—	IC circuit	
				12 V								A73C	—	—	●	—	●	●		—
				5 V, 12 V								A80C	—	—	●	—	●	●		—
Grommet	Yes	—	24 V or less	—	—	—	A79W	—	—	●	—	●	—	—	—					

* Lead wire length symbols: 0.5 m — (Example) M9NW
 1 m M (Example) M9NWM
 3 m L (Example) M9NWL
 5 m Z (Example) M9NWZ
 None N (Example) J79CN

* Solid state switches marked with "○" are produced upon receipt of order.
 * For D-P4DW, ø40 to ø63 are available.
 * Only D-P4DW type is assembled at the time of shipment.

* Since there are other applicable auto switches than listed, refer to page 18 for details.
 * For details about auto switches with pre-wired connector, refer to the "Best Pneumatics" catalogue.
 * When mounting models D-M9□(V), M9□W(V), M9□A(V), and A9□(V) with between ø32 and ø50 on sides other than the port side, please order a switch mounting bracket separately as per the instructions on page 17, and refer to cases CDQP2B32 to 100 in Information (04-E514) "Cylinder with Compact Auto Switch."
 * Auto switches are included, (but not assembled).



Specifications

Bore size (mm)	12	16	20	25	32	40	50	63
Action	Double acting							
Rotation angle <small>Note 1)</small>	90° ±10°							
Rotary direction <small>Note 2)</small>	Clockwise, Counterclockwise							
Rotary stroke (mm)	7.5		9.5		15		19	
Clamp stroke (mm)	10, 20							20, 50
Theoretical clamp force (N) <small>Note 3)</small>	40	75	100	185	300	525	825	1400
Fluid	Air							
Proof pressure	1.5 MPa							
Operating pressure range	0.1 to 1 MPa							
Ambient and fluid temperature	Without auto switch: -10 to 70°C (No freezing) With auto switch: -10 to 60°C (No freezing)							
Lubrication	Non-lube							
Piping port size	M5 x 0.8				Rc1/8, NPT1/8, G1/8		Rc1/4, NPT1/4, G1/4	
Mounting	<small>Through-hole/Both ends tapped common</small> Both ends tapped, Through-hole, Head end flange							
Cushion	Rubber bumper							
Stroke length tolerance	+0.6 -0.4							
Piston speed	50 to 200 mm/s							
Non-rotating accuracy (Clamp part) <small>Note 1)</small>	±1.4°		±1.2°		±0.9°		±0.7°	

Note 1) Refer to "Rotary Angle" figure.

Note 2) Direction of rotation viewed from the rod end when the piston rod is retracting.

Note 3) At 0.5 MPa.

Rotary Angle

During unclamping
(Extension end)
80° to 100°
(90°±10°)
L type

During unclamping
(Extension end)
80° to 100°
(90°±10°)
R type

Clamp part
Non-rotating accuracy
±0.7° to 1.4°
During clamping (Retraction end)



Made to Order
(For details, refer to page 40.)

Symbol	Description
XB6	Head resistant cylinder (150°C)

Theoretical Output

Unit: N

Bore size (mm)	Rod size (mm)	Operating direction	Piston area (cm ²)	Operating pressure (MPa)			
				0.3	0.5	0.7	1.0
12	6	R	0.8	24	40	56	80
		H	1.1	33	55	77	110
16	8	R	1.5	45	75	105	150
		H	2	60	100	140	200
20	12	R	2	60.8	100	139	200
		H	3	90.2	149	208	298
25	12	R	3.7	112	185	258	370
		H	4.9	149	245	341	490
32	16	R	6	182	300	418	600
		H	8	243	400	557	800
40	16	R	10.5	319	525	731	1050
		H	12.5	380	625	870	1250
50	20	R	16.5	502	825	1149	1648
		H	19.6	596	980	1365	1961
63	20	R	28	851	1400	1950	2801
		H	31.2	948	1560	2172	3121

Note) Theoretical output (N) = Pressure (MPa) x Piston area (cm²) x 100

Operating direction
R: Rod end (Clamp)
H: Head end (Unclamp)

Option/Arm

Bore size (mm)	Part no.	Accessories
12	MK-A012	Clamp bolt, Hexagon socket head cap screw, Hexagon nut, Spring washer
16	MK-A016	
20	MK-A020	
25		
32	MK-A032	
40		
50	MK-A050	
63		

Mounting Bracket/Flange

Bore size (mm)	Part no.	Accessories
20	MK-F020	Centering location ring, Set pin, Bolt for cylinder body
25	MK-F025	
32	MK-F032	
40	MK-F040	
50	MK-F050	
63	MK-F063	

Weight/Through-hole Mounting

Unit: g

Clamp stroke (mm)	Bore size (mm)							
	12	16	20	25	32	40	50	63
10	70	100	250	280	500	595	—	—
20	87	123	290	320	525	640	1100	1520
50	—	—	—	—	—	—	1350	1805

Additional Weight

Unit: g

Bore size (mm)	12	16	20	25	32	40	50	63
Both ends tapped	—	—	6	7	7	6	7	17
Rod end width across flats	—	—	10	10	21	21	46	46
With boss on head end	—	—	2	3	5	7	13	25
With arm	13	32	100	100	200	200	350	350
Head end flange(including mounting bolt)	—	—	133	153	166	198	345	531

Calculation: (Example) MKG20-10RFN

- Standard calculation: MKB20-10R 250 g
- Extra weight calculation: Both ends tapped 6 g
- Head end flange 133 g
- With boss on head end 2 g
- With arm 100 g
- 491 g

Series MK

Construction

MK□12, 16

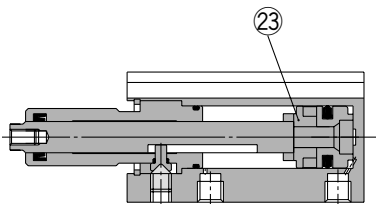

MK□20, 25

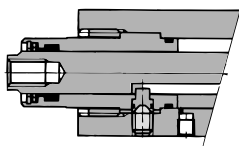

With arm (N)

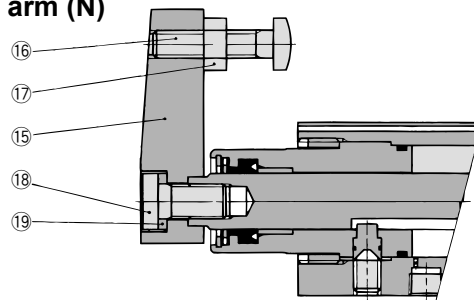

MK□32

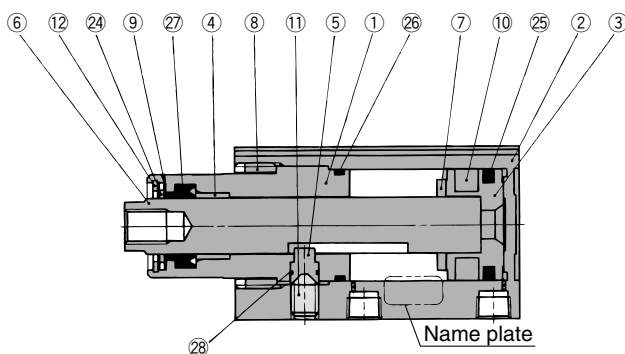

Rod end width across flats (M)

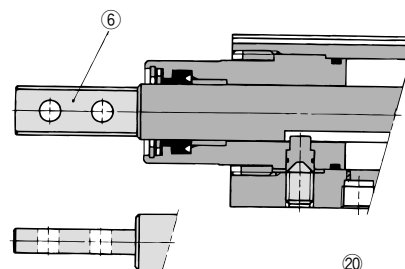

With boss on head end (F)

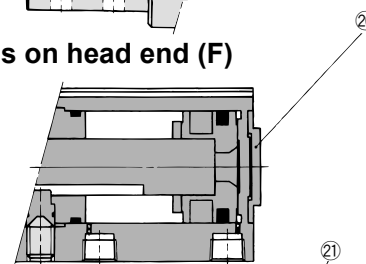

MK□40 to 63

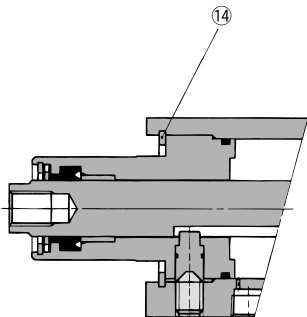

Head end flange (G)

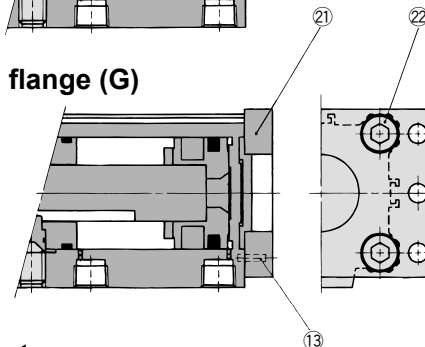

Component Parts

No.	Description	Material	Note
1	Rod cover	Aluminium alloy	Hard anodised
2	Cylinder tube	Aluminium alloy	Hard anodised
3	Piston	Aluminium alloy	
4	Bushing	Copper bearing material	ø32 to ø63 only
5	Guide pin	Stainless steel	Nitrided
6	Piston rod	Stainless steel Carbon steel	ø12 to ø25 Nitrided ø32 to ø63 Heated, Nickel plated
7	Bumper	Urethane	
8	Ring nut	Copper alloy	ø20 to ø32 only
9	Scraper pressure	Stainless steel	Except ø12, ø16
10	Magnet	—	
11	Hexagon socket head set screw	Chromium molybdenum steel	Sharp end section: 90°
12	Round R-type retaining ring	Spring steel	
13	Parallel pin	Stainless steel	
14	C-type retaining ring	Carbon tool steel	Used at ø12, ø16, ø32 to ø63

Component Parts

No.	Description	Material	Note
15	Arm	Rolled steel	
16	Clamp bolt	Chromium molybdenum steel	
17	Hexagon nut	Rolled steel	
18	Hexagon socket head cap screw	Chromium molybdenum steel	
19	Spring washer	Hard steel	
20	Centering location ring	Aluminum alloy	Except ø12, ø16
21	Flange	Rolled steel	Except ø12, ø16
22	Hexagon socket head cap screw	Chromium molybdenum steel	Qty. ø20, ø25: 2 ø32 to ø63: 4
23	Spacer for switch type	Aluminum alloy	ø12, ø16 only
24	Coil scraper	Phosphor bronze	
25	Piston seal	NBR	Except ø12, ø16
26	Gasket	NBR	
27	Rod seal	NBR	
28	O-ring	NBR	

Replacement Parts: Seal Kit

Bore size (mm)	ø12	ø16	ø20 to ø32	ø40	ø50	ø63
Kit no.	MK-12-PS	MK-16-PS	Not able to disassemble	MK-40-PS	MK-50-PS	MK-63-PS
Content	Set of nos. above 24 25 26 27 28					

* Seal kit includes 24 to 28. Order the seal kit, basing on each bore size (except ø20 to ø32).

⚠ Precautions

Be sure to read this before handling. Refer to back page 1 for Safety Instructions and "Precautions for Handling Pneumatic Devices" (M-03-E3A) for Common Precautions.

⚠ Caution

Clamp Arm Mounting

- Use a clamp arm that is available as an option. To fabricate a clamp arm, make sure that the allowable bending moment and the inertial moment are within the specified range. If a clamp arm that exceeds the specified value is installed, the internal mechanism in the cylinder could become damaged.

Ensuring Safety

- If one side of the piston is pressurised by supplying air with the clamp arm attached, the piston will move vertically while the clamp arm rotates. This operation could be hazardous to personnel, as their hands or feet could get caught by the clamp arm, or could lead to equipment damage. Therefore, it is important to secure as a danger zone a cylindrical area with the length of the clamp arm as its radius, and the stroke plus 20 mm as its height.

Installation and Adjustment/ Clamp Arm Removal and Reinstallation

- During the removal or reinstallation of the clamp arm, make sure to use a wrench or a vise to secure the clamp arm before removing or tightening the bolt. This is to prevent the bolt tightening torque from being applied to the piston rod, which could damage the cylinder's internal mecha-

Mounting Bolt for MKB

Mounting: Mounting bolt for through-hole type is available.

Ordering: Add the word "MKB" to the mounting bolt size.

Example) **M5 x 75 L (MKB)**

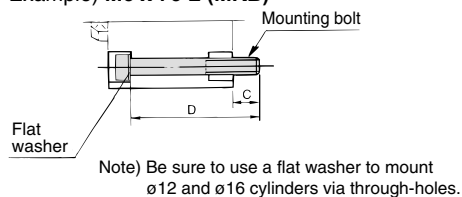

Cylinder model	C	D	Mounting bolt size
MKB12-10	8	50	M3 x 50 L
MKB12-20	8	60	M3 x 60 L
MKB16-10	8	50	M3 x 50 L
MKB16-20	8	60	M3 x 60 L
MKB20-10	10	75	M5 x 75 L
MKB20-20		85	M5 x 85 L
MKB25-10	9	75	M5 x 75 L
MKB25-20		85	M5 x 85 L
MKB32-10	10.5	85	M5 x 85 L
MKB32-20		95	M5 x 95 L
MKB40-10	7	75	M5 x 75 L
MKB40-20		85	M5 x 85 L
MKB50-20	6.5	95	M6 x 95 L
MKB50-50	11.5	130	M6 x 130 L
MKB63-20	10.5	100	M8 x 100 L
MKB63-50		130	M8 x 130 L

Precautions for Designing and Mounting Arms

When arms are to be made separately, their length and weight should be within the following range.

1. Allowable bending moment

Use the arm length and operating pressure in Graph (1) to select an allowable bending moment loaded piston rod.

Graph (1)

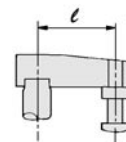
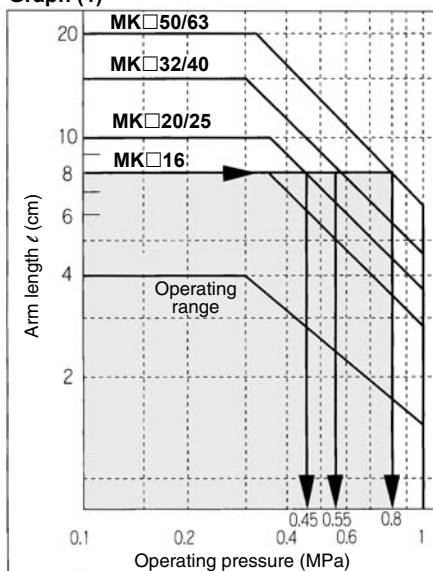

When the arm length is 8 cm, pressure should be less than
 MK□20/25: 0.45 MPa
 MK□32/40: 0.55 MPa
 MK□50/63: 0.8 MPa.

2. Moment of inertia

When the arm is long and heavy, damage of internal parts may be caused due to inertia. Use the inertia moment and cylinder speed in Graph (2) basing on the arm requirements.

Graph (2)

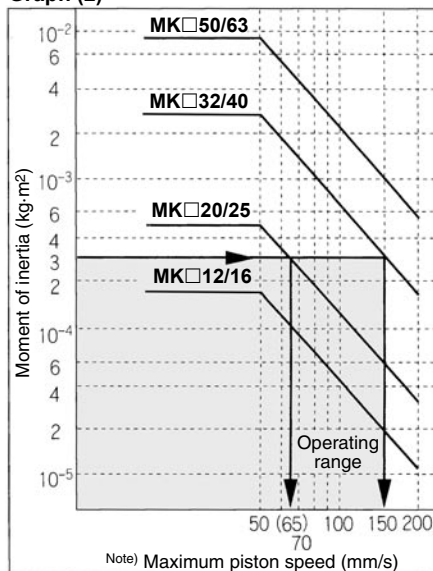

When the arm's moment of inertia is 3×10^{-4} kg·m², the cylinder speed should be less than
 MK□20/25: 65 mm/s
 MK□32/40: 150 mm/s.
 For calculating the moment of inertia, refer to front matter 1, 2, back page 8.

Note) The maximum piston speed is equivalent to approximately 1.6x the average piston speed. (Rough indication)

- To attach and detach the arm to and from the piston rod, fix the arm with a wrench or vise and then tighten the bolt. (If an excessive force is applied in the rotary direction, it may cause damage to the internal mechanism.) Refer to the following table for the tightening torque for mounting.

Bore size (mm)	Proper tightening torque (N·m)
12	0.4 to 0.6
16	2 to 2.4
20, 25	4 to 6
32, 40	8 to 10
50, 63	14 to 16

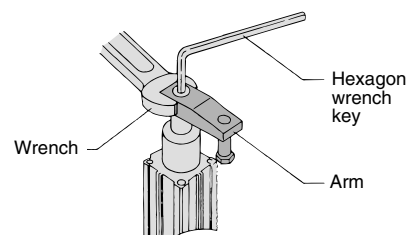

Series MK



Dimensions: $\phi 12$, $\phi 16$, $\phi 20$, $\phi 25$

Through-hole (Basic): MKB

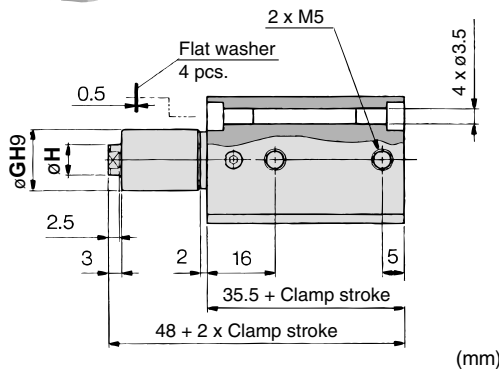

$\phi 12$

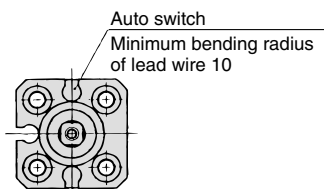

$\phi 16$

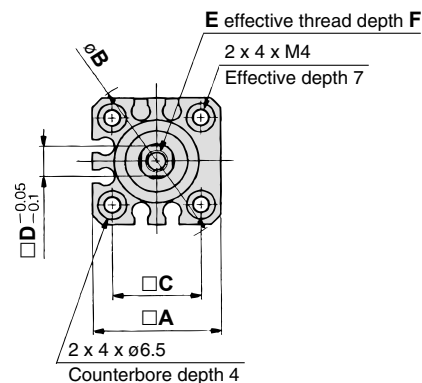

Model	A	B	C	D	E	F	G	H
MKB12	25	32	15.5	5	M3	5.5	11h9 ⁰ _{-0.043}	6
MKB16	29	38	20	7	M5	6.5	14h9 ⁰ _{-0.043}	8

Model	M	N	O	P	Q	R	S
MKB12-□□N	18.5	8	29	20	4	M3	8
MKB16-□□N	21.5	11	36	25	5	M4	11

With arm: MK□¹²/₁₆-□□N

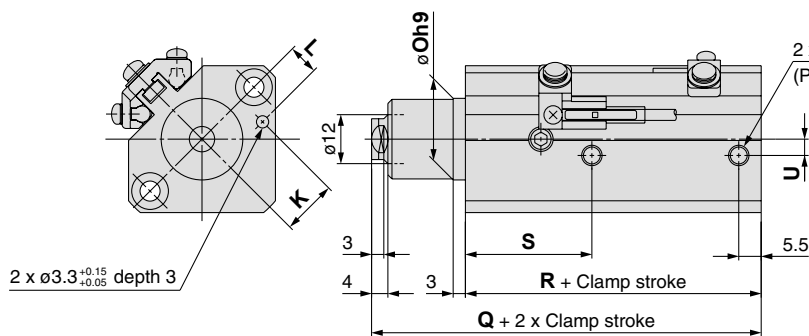
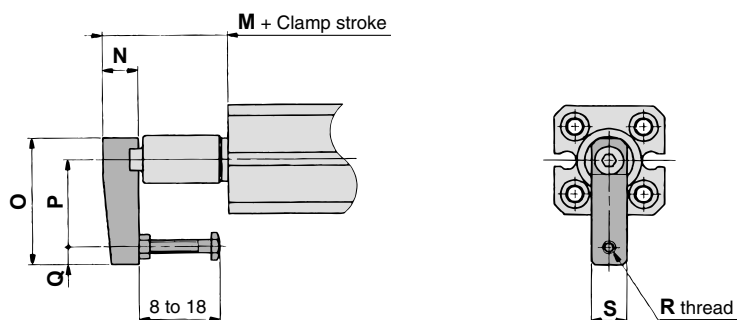

$\phi 20, \phi 25$

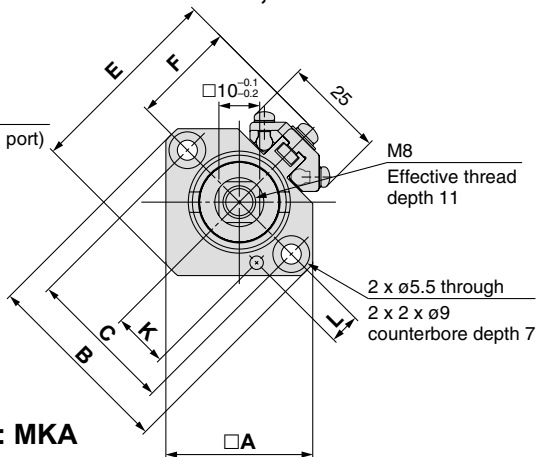

Both ends tapped: MKA

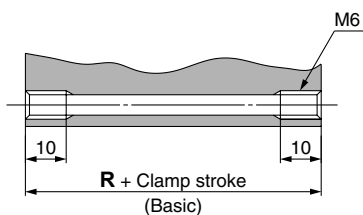

Model	A	B	C	E	F	K	L	Oh9	Q	R	S	U
MKB20	36	46.8	36	49	25.5	13.5 ^{+0.15}	7.5 ^{+0.15}	20 ⁰ _{-0.052}	72.5	62	31	4
MKB25	40	52	40	54.5	28.5	16 ^{+0.15}	8 ^{+0.15}	23 ⁰ _{-0.052}	73.5	63	32	5

Note) Dimension when the rod is extended is to be added to the clamp stroke plus rotary stroke.

Head end flange: MKG

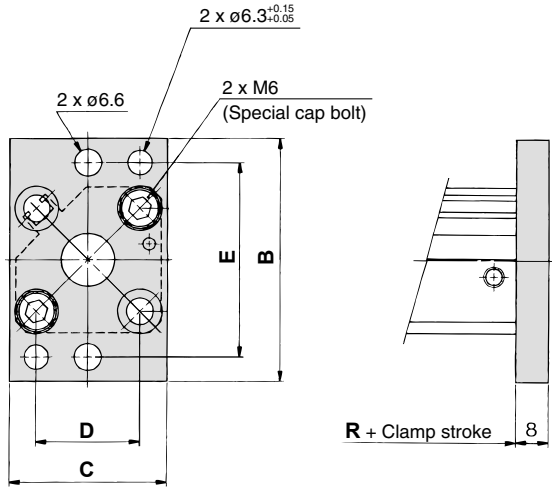

Model	B	C	D	E
MKG20	60	39	25.5 \pm 0.1	48 \pm 0.15
MKG25	64	42	28 \pm 0.1	52 \pm 0.15

With boss on head end

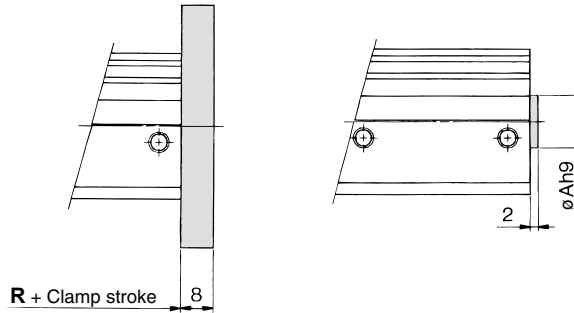

Model	Ah9
MK□20-□□F	13 $\begin{smallmatrix} 0 \\ -0.043 \end{smallmatrix}$
MK□25-□□F	15 $\begin{smallmatrix} 0 \\ -0.043 \end{smallmatrix}$

With arm: MK□ $\frac{20}{25}$ -□□N

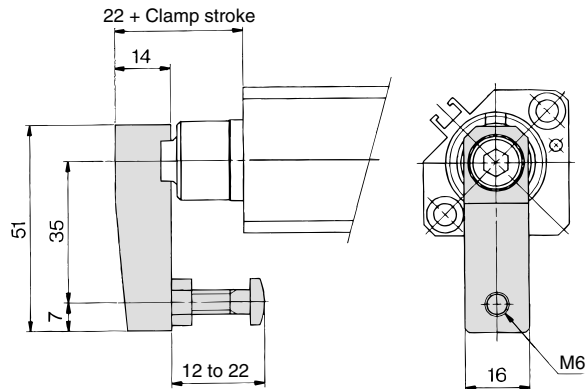

Rod end width across flats: MK□ $\frac{20}{25}$ -□□M

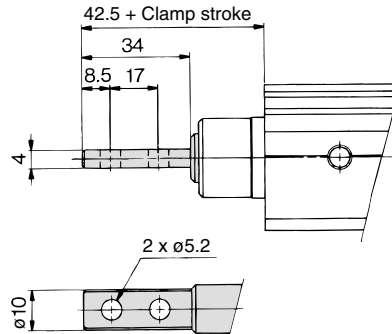

Series MK



Dimensions: $\varnothing 32$, $\varnothing 40$, $\varnothing 50$, $\varnothing 63$

Through-hole (Basic): MKB

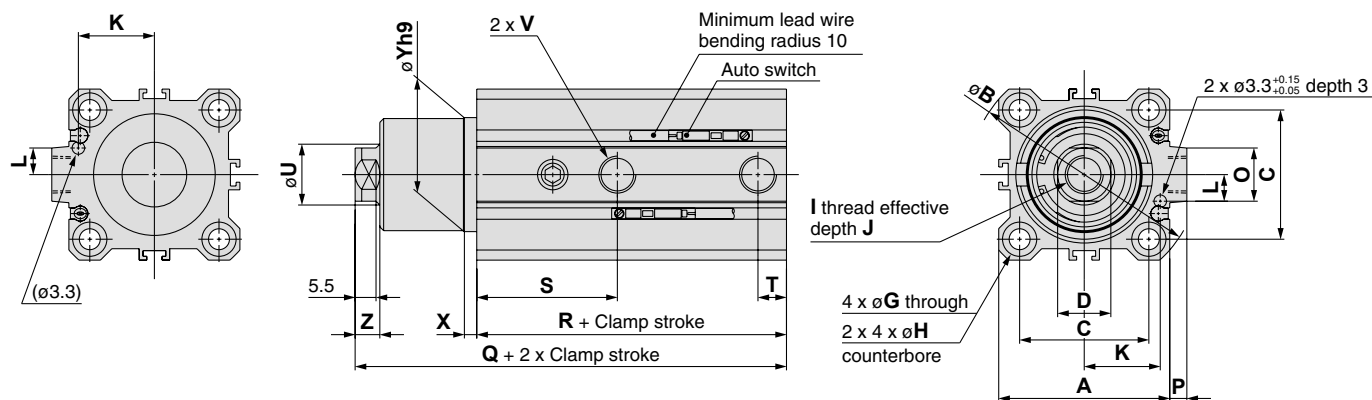

Both ends tapped: MKA

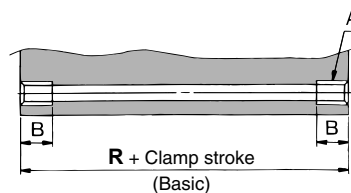

Model	A	B
MKA ³² ₄₀	M6	10
MKA ₅₀	M8	14
MKA ₆₃	M10	18

Model	A	B	C	D	G	H	I	J	K	L	M	N	O	P	Q	R	S	T	U	V			X	Yh9	Z
																				—	TN	TF			
MKB32	45	60	34	14 ^{-0.1} _{-0.2}	5.5	9 depth 7	M10	12	20 ^{±0.15}	7 ^{±0.15}	M6	10	14	4.5	93.5	71.5	37	7.5	16	Rc1/8	NPT1/8	G1/8	3	30 ⁰ _{-0.062}	6.5
MKB40	52	69	40	14 ^{-0.1} _{-0.2}	5.5	9 depth 7	M10	12	24 ^{±0.15}	7 ^{±0.15}	M6	10	14	5	94.5	65	29.5	8	16	Rc1/8	NPT1/8	G1/8	3	30 ⁰ _{-0.062}	6.5
MKB50	64	86	50	17 ^{-0.1} _{-0.2}	6.6	11 depth 8	M12	15	30 ^{±0.15}	8 ^{±0.15}	M8	14	19	7	112	76.5	34	10.5	20	Rc1/4	NPT1/4	G1/4	3.5	37 ⁰ _{-0.062}	7.5
MKB63	77	103	60	17 ^{-0.1} _{-0.2}	9	14 depth 10.5	M12	15	35 ^{±0.15}	9 ^{±0.15}	M10	18	19	7	115	80	35	10.5	20	Rc1/4	NPT1/4	G1/4	3.5	48 ⁰ _{-0.062}	7.5



Note 1) Figures above are for D-M9□, M9□W, M9□A, A9□.

Note 2) Dimension when the rod is extended is to be added to the clamp stroke plus rotary stroke.

Head end flange: MKG

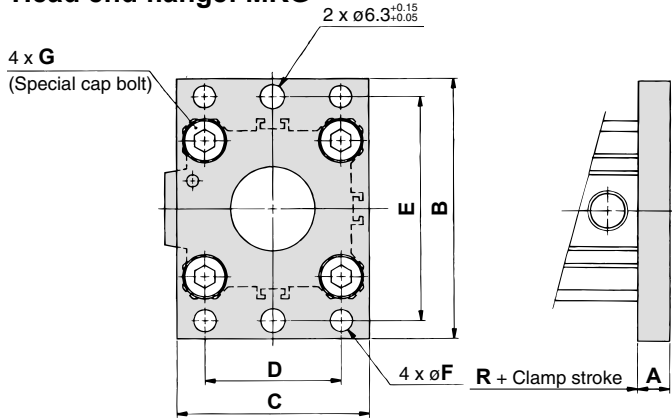

Model	A	B	C	D	E	F	G
MKG32	8	65	48	34 ±0.1	56 ±0.15	5.5	M6
MKG40	8	72	54	40 ±0.1	62 ±0.15	5.5	M6
MKG50	9	89	67	50 ±0.1	76 ±0.15	6.6	M8
MKG63	9	108	80	60 ±0.1	92 ±0.15	9	M10

With boss on head end

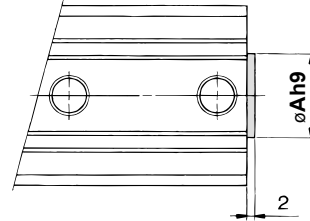

Model	Ah9
MK□32-□□F	21 ⁰ _{-0.052}
MK□40-□□F	28 ⁰ _{-0.052}
MK□ ⁵⁰ / ₆₃ -□□F	35 ⁰ _{-0.062}

With arm

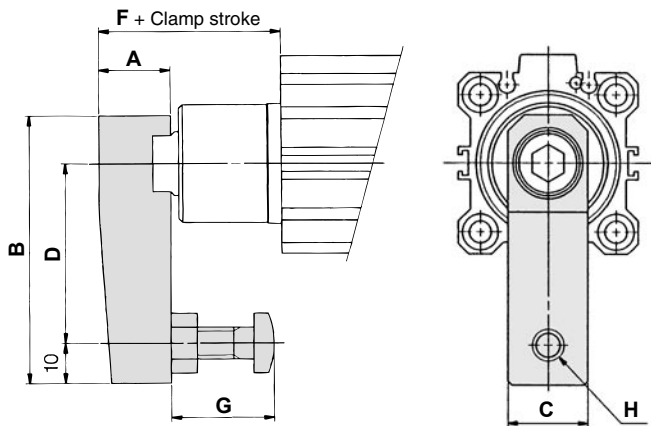

Model	A	B	C	D	F	G	H
MK□32-□□N	18	67	20	45	35.5	15 to 25	M8
MK□40-□□N	18	67	20	45	43		M8
MK□50-□□N	22	88	22	65	53	30 to 40	M10
MK□63-□□N	22	88	22	65	52.5		M10

Rod end width across flats

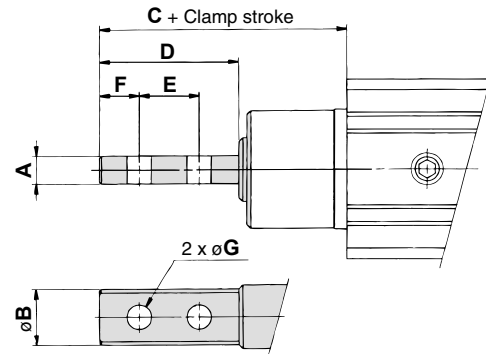

Model	A	B	C	D	E	F	G
MK□32-□□M	6	14	53.5	36	18	9	6.2
MK□40-□□M	6	14	61	36	18	9	6.2
MK□50-□□M	8	18	77	46	23	11.5	8.2
MK□63-□□M	8	18	76.5	46	23	11.5	8.2

Rotary Clamp Cylinder: Heavy Duty Type

Series MK2

ø20, ø25, ø32, ø40, ø50, ø63

How to Order

MK2 B 20 - **10 R F** - **M9BW**

Rotary clamp cylinder
Heavy duty type

Mounting bracket

B	Through-hole/Both ends tapped common (Standard)
G	Head end flange

* Head end flange is equipped with a boss mounting. Be sure to specify body option "F".
* Mounting bracket is included, (but not assembled).

Bore size

20	20 mm	40	40 mm
25	25 mm	50	50 mm
32	32 mm	63	63 mm

Port thread type

—	M thread	ø20, ø25
	Rc	
TN	NPT	ø32 to ø63
TF	G	

Clamp stroke

Symbol	Clamp stroke	Applicable bore size
10	10 mm	ø20 to ø40
20	20 mm	ø20 to ø63
50	50 mm	ø50 to ø63

Number of auto switches

—	2 pcs.
S	1 pc.

Auto switch type

—	Without auto switch (Built-in magnet)
---	---------------------------------------

* For applicable auto switch models, refer to the table below.

Body option

—	Standard (Female thread)
F	With boss on head end
N	With arm

* Arms are assembled at the time of shipment.

Rotary direction (Unclamp → Clamp)

R	Clockwise
L	Counterclockwise

Applicable Auto Switches

Refer to page 29 through 39 for further information on auto switches.

Type	Special function	Electrical entry	Indicator light	Wiring (Output)	Load voltage		Auto switch model		Lead wire length (m)					Pre-wired connector	Applicable load						
					DC	AC	Perpendicular	In-line		0.5 (—)	1 (M)	3 (L)	5 (Z)			None (N)					
								ø20 to ø32	ø40 to ø63												
Solid state switch	—	Grommet	No	3-wire (NPN)	24 V	5 V, 12 V	—	M9NV	M9N	●	—	●	○	—	○	IC circuit	Relay, PLC				
				3-wire (PNP)				M9PV	M9P	●	—	●	○	—	○						
		Connector		2-wire				M9BV	M9B	●	—	●	○	—	○						
				—				J79C	—	●	—	●	●	●	—			—			
	Diagnostic indication (2-colour indication)	Grommet	Yes	3-wire (NPN)	24 V	5 V, 12 V	—	M9NWW	M9NW	●	●	●	○	—	○	IC circuit					
				3-wire (PNP)				M9PWW	M9PW	●	●	●	○	—	○						
		Connector		2-wire				M9BWW	M9BW	●	●	●	○	—	○	—					
				—				M9NAV	M9NA	○	○	●	○	—	○						
		Water resistant (2-colour indication)		Grommet				3-wire (NPN)	24 V	5 V, 12 V	—	M9PAV	M9PA	○	○	●		○	—	○	IC circuit
								3-wire (PNP)				M9BAV	M9BA	○	○	●		○	—	○	
Diagnostic output (2-colour indication)	Grommet	Yes	2-wire	24 V	12 V	—	—	F79F	●	—	●	○	—	○	IC circuit						
Magnetic field resistant (2-colour indication)			2-wire (No polarity)				—	—	P4DW	—	—	●	●	—		○	—				
Reed switch	—	Grommet	Yes	3-wire (NPN equivalent)	24 V	5 V	—	A96V	A96	●	—	●	—	—	—	IC circuit					
				Connector				2-wire	12 V	200 V	A72	A72H	●	—	●		—	—	—		
									12 V	100 V	A93V	A93	●	—	●		—	—	—		
	Diagnostic indication (2-colour indication)	Grommet	Yes	2-wire	24 V	5 V, 12 V	100 V or less	A90V	A90	●	—	●	—	—	—	IC circuit					
								12 V	—	A73C	—	●	—	●	●		●	—	—		
	Water resistant (2-colour indication)	Grommet	Yes	2-wire	24 V	5 V, 12 V	24 V or less	A80C	—	●	—	●	●	●	—	IC circuit					
								—	—	A79W	—	●	—	●	—		—	—	—		

* Lead wire length symbols: 0.5 m — (Example) M9NW
 1 m M (Example) M9NWM
 3 m L (Example) M9NWL
 5 m Z (Example) M9NWX
 None N (Example) J79CN

* Solid state switches marked with "○" are produced upon receipt of order.
 * For D-P4DW, ø40 to ø63 are available.
 * Only D-P4DW type is assembled at the time of shipment.

* Since there are other applicable auto switches than listed, refer to page 18 for details.
 * For details about auto switches with pre-wired connector, refer to the "Best Pneumatics" catalogue.
 * When mounting models D-M9□(V), M9□W(V), M9□A(V), and A9□(V) with between ø32 and ø50 on sides other than the port side, please order a switch mounting bracket separately as per the instructions on page 17, and refer to cases CDQP2B32 to 100 in Information (04-E514) "Cylinder with Compact Auto Switch."
 * Auto switches are included, (but not assembled).

Rotary Clamp Cylinder: Heavy Duty Type **Series MK2**

Specifications



Bore size (mm)	20	25	32	40	50	63
Action	Double acting					
Rotation angle ^{Note 1)}	90° ±10°					
Rotary direction ^{Note 2)}	Clockwise, Counterclockwise					
Rotary stroke (mm)	9.5		15		19	
Clamp stroke (mm)	10, 20				20, 50	
Theoretical clamp force (N) ^{Note 3)}	100	185	300	525	825	1400
Fluid	Air					
Proof pressure	1.5 MPa					
Operating pressure range	0.1 to 1 MPa					
Ambient and fluid temperature	Without auto switch: -10 to 70°C (No freezing)					
	With auto switch: -10 to 60°C (No freezing)					
Lubrication	Non-lube					
Piping port size	M5 x 0.8		Rc1/8, NPT1/8, G1/8		Rc1/4, NPT1/4, G1/4	
Mounting	Through-hole/Both ends tapped common, Head end flange					
Cushion	Rubber bumper					
Stroke length tolerance	+0.6 -0.4					
Piston speed	50 to 200 mm/s					
Non-rotating accuracy (Clamp part)	±1.2°		±0.9°		±0.7°	

Note 1) Refer to the "Rotary Angle" figure.

Note 2) Direction of rotation viewed from the rod end when the piston rod is retracting.

Note 3) At 0.5 MPa.

Rotary Angle

During unclamping
(Extension end)
80° to 100°
(90°±10°)
L type

During unclamping
(Extension end)
80° to 100°
(90°±10°)
R type

Clamp part
Non-rotating accuracy
±0.7° to 1.2°
During clamping (Retraction end)

Theoretical Output

Unit: N

Bore size (mm)	Rod size (mm)	Operating direction	Piston area (cm ²)	Operating pressure (MPa)			
				0.3	0.5	0.7	1.0
20	12	R	2	60.8	100	139	200
		H	3	90.2	149	208	298
25	12	R	3.7	112	185	258	370
		H	4.9	149	245	341	490
32	16	R	6	182	300	418	600
		H	8	243	400	557	800
40	16	R	10.5	319	525	731	1050
		H	12.5	380	625	870	1250
50	20	R	16.5	502	825	1149	1648
		H	19.6	596	980	1365	1961
63	20	R	28	851	1400	1950	2801
		H	31.2	948	1560	2172	3121

Note) Theoretical output (N) = Pressure (MPa) x Piston area (cm²) x 100

Operating direction
R: Rod end (Clamp)
H: Head end (Unclamp)

Option/Arm

Bore size (mm)	Part no.	Accessories
20	MK-A020Z	Clamp bolt, Hexagon socket head cap screw, Hexagon nut, Spring washer
25		
32		
40	MK-A032Z	
50		
63	MK2T-A063	

Mounting Bracket/Flange

Bore size (mm)	Part no.	Accessories
20	CQS-F020	Centering location ring, Set pin, Bolt for cylinder body
25	CQS-F025	
32	MK2-F032	
40	MK2-F040	
50	MK2-F050	
63	MK2-F063	

Weight/Through-hole Mounting

Unit: g

Clamp stroke (mm)	Bore size (mm)					
	20	25	32	40	50	63
10	260	295	353	635	—	—
20	300	335	555	680	1170	1620
50	—	—	—	—	1420	1890

Additional Weight

Unit: g

Bore size (mm)	20	25	32	40	50	63
With boss on head end	2	3	5	7	13	25
With arm	100	100	200	200	350	350
Head end flange (including mounting bolt)	133	153	166	198	345	531

Calculation: (Example) MK2G20-10RFN

• Standard calculation: MK2B20-10R 260 g
 • Extra weight calculation: Head end flange 133 g
 With boss on head end 2 g
 With arm 100 g
 495 g

Series MK2

Construction

MK2□20, 25

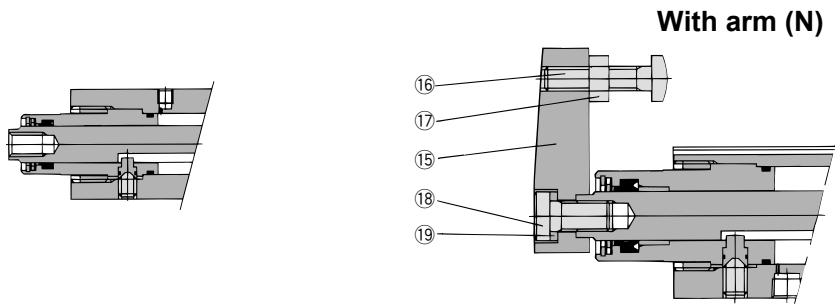

MK2□32

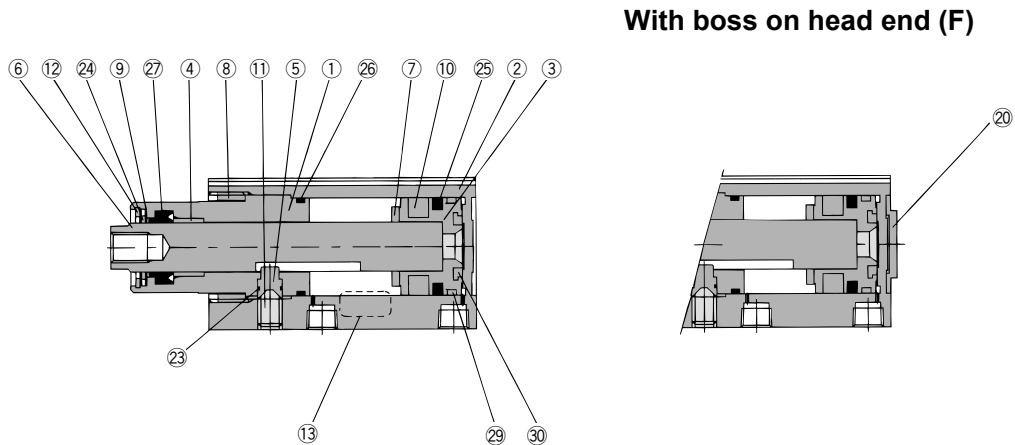

MK2□40 to 63

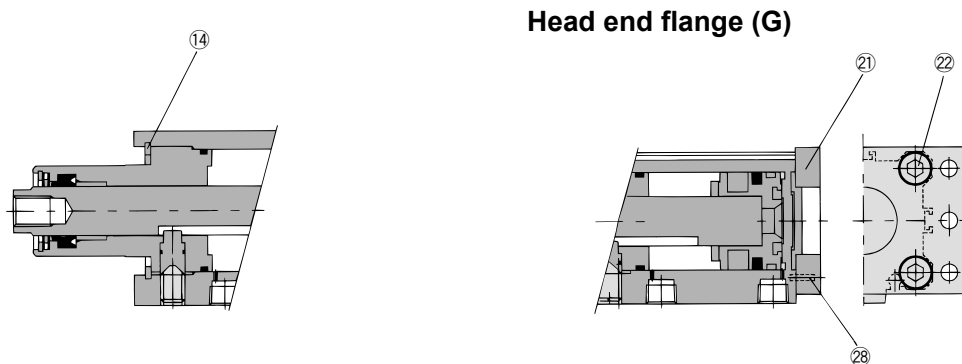

Component Parts

No.	Description	Material	Note
1	Rod cover	Aluminium alloy	
2	Cylinder tube	Aluminium alloy	
3	Piston	Aluminium alloy	
4	Bushing	Copper bearing material	ø32 to ø63 only
5	Guide pin	Stainless steel	Nitrided
6	Piston rod	Stainless steel	ø20, ø25 Nitrided
		Carbon steel	ø32 to ø63 Heated, Nickel plated
7	Bumper	Urethane	
8	Ring nut	Copper alloy	ø20 to ø32 only
9	Scraper pressure	Stainless steel	
10	Magnet	—	
11	Hexagon socket head set screw	Chromium molybdenum steel	Sharp end section: 90°
12	Round R-type retaining ring	Spring steel	
13	Name plate	Aluminium	
14	C-type retaining ring	Carbon tool steel	ø40 to ø63 only
15	Arm	Rolled steel	

Component Parts

No.	Description	Material	Note
16	Clamp bolt	Chromium molybdenum steel	
17	Hexagon nut	Rolled steel	
18	Hexagon socket head cap screw	Chromium molybdenum steel	
19	Spring washer	Hard steel	
20	Centering location ring	Aluminium alloy	
21	Flange	Rolled steel	
22	Hexagon socket head cap screw	Chromium molybdenum steel	Qty. ø20, ø25: 2 ø32 to ø63: 4
23	O-ring	NBR	
24	Coil scraper	Phosphor bronze	
25	Piston seal	NBR	
26	Gasket	NBR	
27	Rod seal	NBR	
28	Parallel pin	Stainless steel	
29	Wear ring	Resin	
30	Bumper B	Urethane	

Replacement Parts: Seal Kit

Bore size (mm)	20	25	32	40	50	63
Kit no.	Not able to disassemble			MK2-40-PS	MK2-50-PS	MK2-63-PS
Content	Set of nos. above 23 24 25 26 27					

* Seal kit includes 23 to 27. Order the seal kit, basing on each bore size.

⚠️ Precautions

Be sure to read this before handling. Refer to back page 1 for Safety Instructions and "Precautions for Handling Pneumatic Devices" (M-03-E3A) for Common Precautions.

⚠️ Caution

Clamp Arm Mounting

- Use a clamp arm that is available as an option. To fabricate a clamp arm, make sure that the allowable bending moment and the inertial moment are within the specified range. If a clamp arm that exceeds the specified value is installed, the internal mechanism in the cylinder could become damaged.

Ensuring Safety

- If one side of the piston is pressurised by supplying air with the clamp arm attached, the piston will move vertically while the clamp arm rotates. This operation could be hazardous to personnel, as their hands or feet could get caught by the clamp arm, or could lead to equipment damage. Therefore, it is important to secure as a danger zone a cylindrical area with the length of the clamp arm as its radius, and the stroke plus 20 mm as its height.

Installation and Adjustment/ Clamp Arm Removal and Reinstallation

- During the removal or reinstallation of the clamp arm, make sure to use a wrench or a vise to secure the clamp arm before removing or tightening the bolt. This is to prevent the bolt tightening torque from being applied to the piston rod, which could damage the cylinder's internal mechanism.

Mounting Bolt for MK2B

Mounting: Mounting bolt for through-hole type is available.

Ordering: Add the word "MK2B" to the mounting bolt size.

Example) **M5 x 75 L (MK2B)**

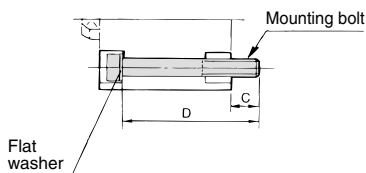

Note) Be sure to use a flat washer to mount cylinders via through-holes.

Cylinder model	C	D	Mounting bolt size
MK2B20-10	8.5	75	M5 x 75 L
MK2B20-20		85	M5 x 85 L
MK2B25-10	10.5	80	M5 x 80 L
MK2B25-20		90	M5 x 90 L
MK2B32-10	10	90	M5 x 90 L
MK2B32-20		100	M5 x 100 L
MK2B40-10	6	80	M5 x 80 L
MK2B40-20		90	M5 x 90 L
MK2B50-20	10.5	105	M6 x 105 L
MK2B50-50	10.5	135	M6 x 135 L
MK2B63-20	9	105	M8 x 105 L
MK2B63-50		135	M8 x 135 L

Precautions for Designing and Mounting Arms

When arms are to be made separately, their length and weight should be within the following range.

1. Allowable bending moment

Use the arm length and operating pressure in Graph (1) to select an allowable bending moment loaded piston rod.

Graph (1)

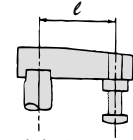
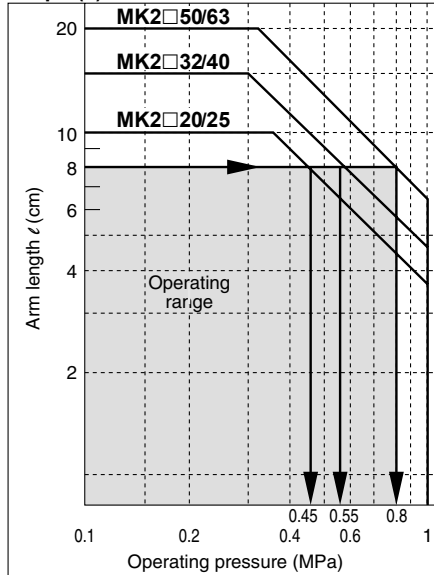

When the arm length is 8 cm, pressure should be less than
 MK2 20/25: 0.45 MPa
 MK2 32/40: 0.55 MPa
 MK2 50/63: 0.8 MPa.

2. Moment of inertia

When the arm is long and heavy, damage of internal parts may be caused due to inertia. Use the inertia moment and cylinder speed in Graph (2) basing on the arm requirements.

Graph (2)

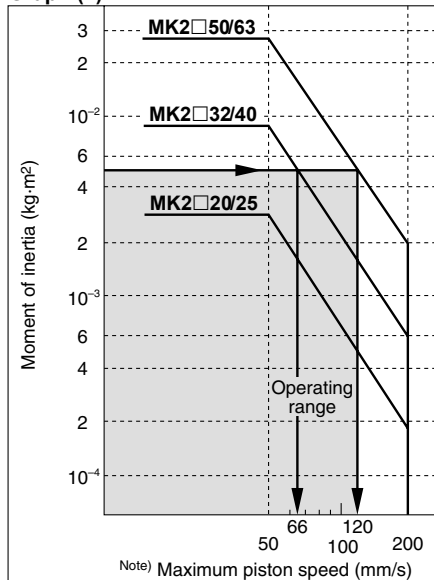

When the arm's moment of inertia is 5×10^{-3} kg·m², the cylinder speed should be less than
 MK2 32/40: 66 mm/s
 MK2 50/63: 120 mm/s.
 For calculating the moment of inertia, refer to front matter 1, 2, back page 8.

Note) The maximum piston speed is equivalent to approximately 1.6x the average piston speed. (Rough indication)

- To attach and detach the arm to and from the piston rod, fix the arm with a wrench or vise and then tighten the bolt. (If an excessive force is applied in the rotary direction, it may cause damage to the internal mechanism.) Refer to the following table for the tightening torque for mounting.

Bore size (mm)	Proper tightening torque (N·m)
20, 25	4 to 6
32, 40	8 to 10
50, 63	14 to 16

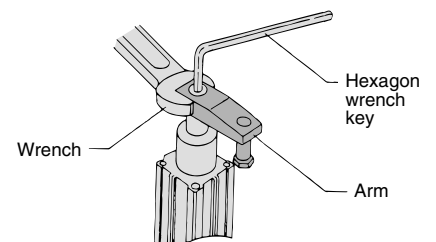

Series MK2

Dimensions: $\phi 20$, $\phi 25$

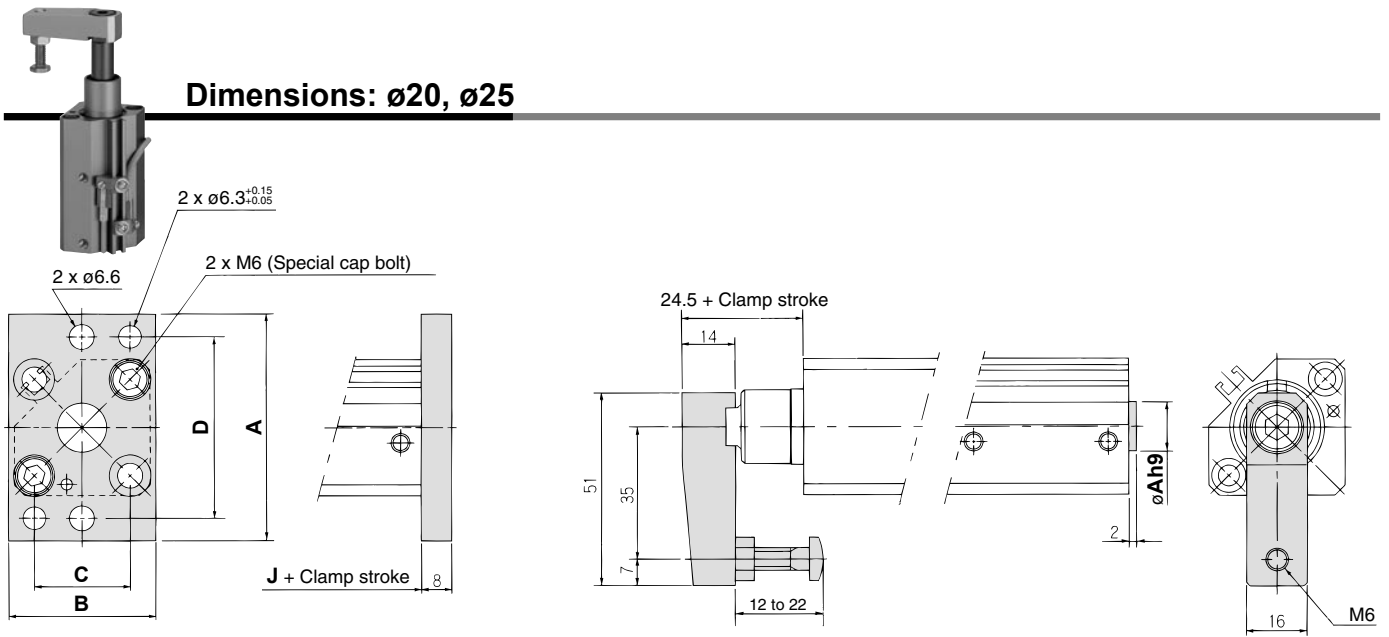

Head End Flange (mm)

Model	A	B	C	D
MK2G20	60	39	25.5 ^{+0.1}	48 ^{+0.15}
MK2G25	64	42	28 ^{+0.1}	52 ^{+0.15}

With Boss on Head End (mm)

Model	$\phi Ah9$
MK2□20-□□F	13 ⁰ _{-0.043}
MK2□25-□□F	15 ⁰ _{-0.043}

With arm

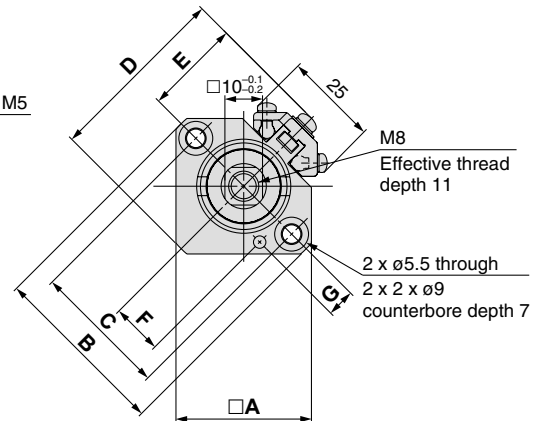
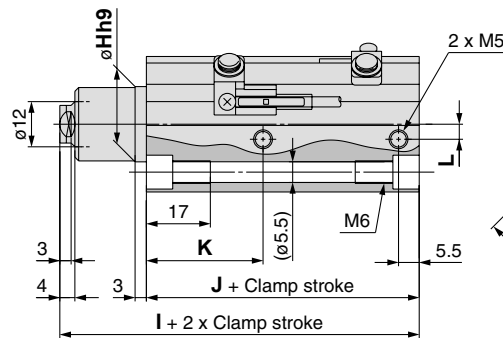
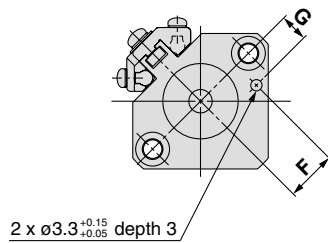

Through-hole/Both Ends Tapped Common (Standard) (mm)

Model	□A	B	C	D	E	F	G	$\phi Hh9$	I	J	K	L
MK2B20	36	46.8	36	49	25.5	13.5 ^{+0.15}	7.5 ^{+0.15}	20 ⁰ _{-0.052}	75.5	62.5	31	4
MK2B25	40	52	40	54.5	28.5	16 ^{+0.15}	8 ^{+0.15}	23 ⁰ _{-0.052}	78.5	65.5	32	5

Note) Dimension when the rod is extended is to be added to the clamp stroke plus rotary stroke.

Rotary Clamp Cylinder: Heavy Duty Type **Series MK2**



Dimensions: $\varnothing 32$, $\varnothing 40$, $\varnothing 50$, $\varnothing 63$

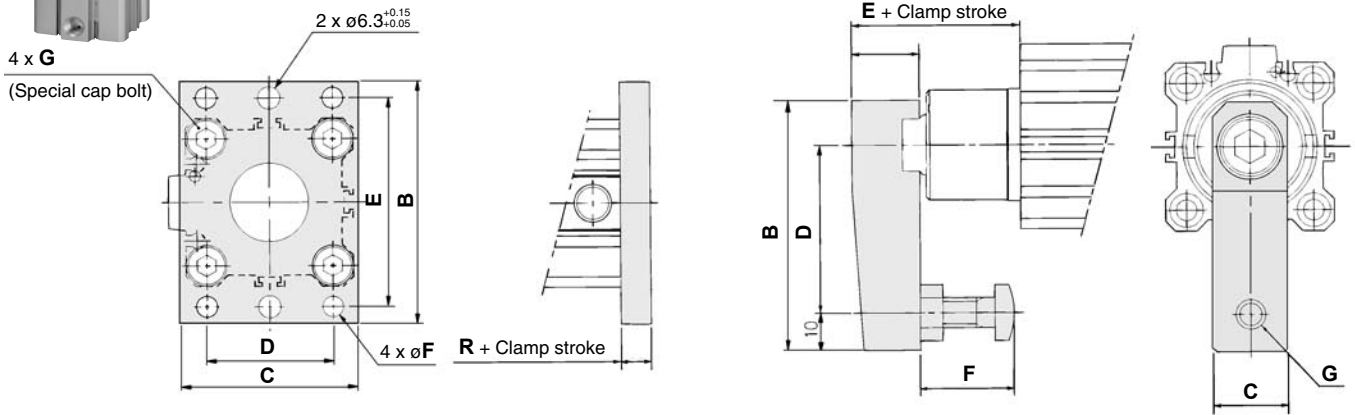

Head End Flange

Model	A	B	C	D	E	$\varnothing F$	G
MK2G32	8	65	48	34 $^{\pm 0.1}$	56 $^{\pm 0.15}$	5.5	M6
MK2G40	8	72	54	40 $^{\pm 0.1}$	62 $^{\pm 0.15}$	5.5	M6
MK2G50	9	89	67	50 $^{\pm 0.1}$	76 $^{\pm 0.15}$	6.6	M8
MK2G63	9	108	80	60 $^{\pm 0.1}$	92 $^{\pm 0.15}$	9	M10

With Arm

Model	A	B	C	D	E	F	G
MK2\square32-$\square$$\square$N	18	67	20	45	39	15 to 25	M8
MK2\square40-$\square$$\square$N	18	67	20	45	46		M8
MK2\square50-$\square$$\square$N	22	88	22	65	58	30 to 40	M10
MK2\square63-$\square$$\square$N	22	88	22	65	57.5		M10

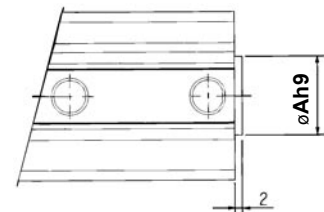

With Boss on Head End

Model	$\varnothing Ah9$
MK2\square32-$\square$$\square$F	21 $^0_{-0.052}$
MK2\square40-$\square$$\square$F	28 $^0_{-0.052}$
MK2$\square$$\frac{50}{63}$-$\square$$\square$F	35 $^0_{-0.062}$

Note) The figures below illustrate auto switches D-M9 \square , M9 \square W, M9 \square A, and A9 \square .

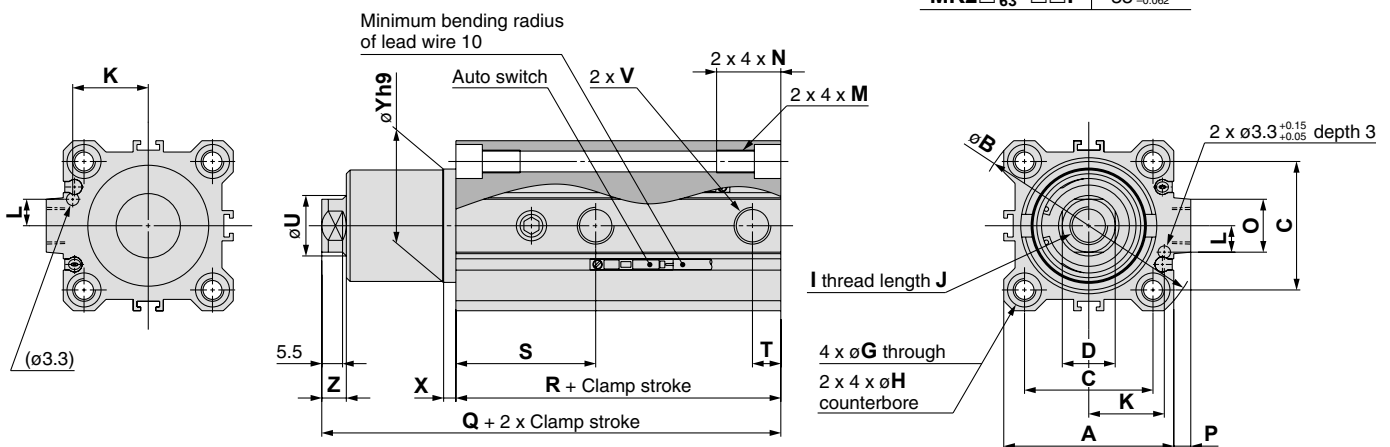

Through-hole/Both Ends Tapped Common (Standard)

Model	$\square A$	B	C	D	E	F	$\varnothing G$	$\varnothing H$	I	J	K	L	M	N	O	P	Q	R	S	T	$\varnothing U$	V			X	$\varnothing Yh9$	Z
																						TN	TF				
MK2B32	45	60	34	14 $^{\pm 0.1}_{-0.2}$	54	31.5	5.5	9 depth 7	M10	12	20 $^{\pm 0.15}$	7 $^{\pm 0.15}$	M6	17	14	4.5	101.5	76	37	7.5	16	Rc1/8	NPT1/8	G1/8	3	30 $^0_{-0.062}$	6.5
MK2B40	52	69	40	14 $^{\pm 0.1}_{-0.2}$	61	35	5.5	9 depth 7	M10	12	24 $^{\pm 0.15}$	7 $^{\pm 0.15}$	M6	17	14	5	102.5	70	29.5	8	16	Rc1/8	NPT1/8	G1/8	3	30 $^0_{-0.062}$	6.5
MK2B50	64	86	50	17 $^{\pm 0.1}_{-0.2}$	73	41	6.6	11 depth 8	M12	15	30 $^{\pm 0.15}$	8 $^{\pm 0.15}$	M8	22	19	7	122	81.5	34	10.5	20	Rc1/4	NPT1/4	G1/4	3.5	37 $^0_{-0.062}$	7.5
MK2B63	77	103	60	17 $^{\pm 0.1}_{-0.2}$	86	47.5	9	14 depth 10.5	M12	15	35 $^{\pm 0.15}$	9 $^{\pm 0.15}$	M10	28.5	19	7	125	85	35	10.5	20	Rc1/4	NPT1/4	G1/4	3.5	48 $^0_{-0.062}$	7.5

- Note 1) The cylinder rod is retracted.
- Note 2) Rotary direction is viewed from the rod end when the piston rod is retracting.
- Note 3) Dimension when the rod is extended is to be added to the clamp stroke plus rotary stroke.

Series MK/MK2

Auto Switch Proper Mounting Position (Detection at Stroke End) and its Mounting Height

Applicable Cylinders: MK Series

ø12

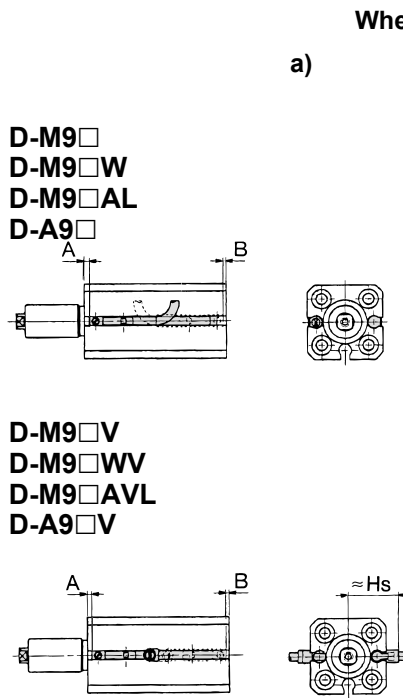

ø16

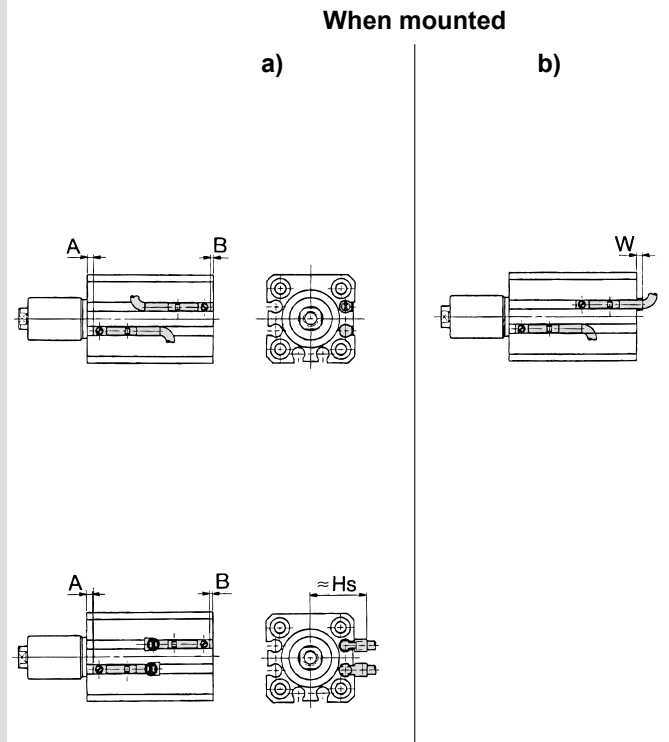

Auto Switch Proper Mounting Position

(mm)

Auto switch model	D-M9□/M9□V D-M9□W/M9□WV D-M9□AL/M9□AVL			D-A9□ D-A9□V		
	A	B	W	A	B	W
Bore size 12	11.5	4.5	5.5	7.5	0	1.5 (4)
16	12	4	6	8	0	2 (4.5)

Note 1) (): D-A93

Note 2) Size W is suitable for mounting models D-M9□, D-M9□W, D-M9□AL, and D-A9□.

Note 3) When setting an auto switch, confirm the operation and adjust its mounting position.

Auto Switch Mounting Height

(mm)

Auto switch model	D-M9□V D-M9□WV D-M9□AVL	D-A9□V
	Hs	Hs
Bore size 12	19	17
16	21	19

Auto Switch Proper Mounting Position (Detection at Stroke End) and its Mounting Height

Applicable Cylinders: MK, MK2 Series

D-M9□
D-M9□V
D-M9□W
D-M9□WV
D-M9□AL
D-M9□AVL
D-A9□
D-A9□V

ø20, ø25

ø32 to ø63

ø20, ø25

ø32 to ø63

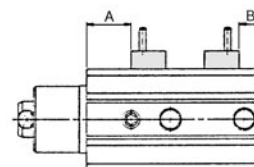
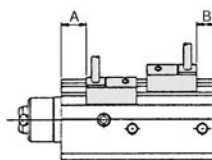
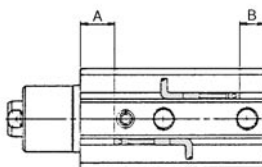
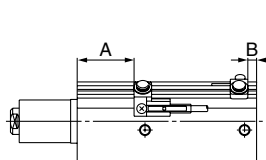

Auto Switch Proper Mounting Position

Applicable Cylinders: MK Series

Auto switch model	D-M9□ D-M9□V D-M9□WV D-M9□W D-M9□AL D-M9□AVL		D-A9□ D-A9□V		D-A73 D-A80		D-A72/A7□H D-A80H/A73C D-A80C/F7□/F79F D-J79/F7□V/J79C D-F7BA□/F7□W D-J79W/F7□WV		D-F7NTL		D-A79W		D-P4DWL	
	A	B	A	B	A	B	A	B	A	B	A	B	A	B
Bore size 20	30	7.5	26	3.5	28.5	6	29	6.5	34	11.5	26	3.5	—	—
25	30.5	8	26.5	4	29	6.5	29.5	7	34.5	12	26.5	4	—	—
32	35.5	9	31.5	5	32.5	6	33	6.5	38	11.5	30	3.5	—	—
40	26.5	11.5	22.5	7.5	23.5	8.5	24	9	29	14	21	6	19.5	4.5
50	31	14.5	27	10.5	28	11.5	28.5	12	33.5	17	25.5	9	24	7.5
63	31.5	17.5	27.5	13.5	28.5	14.5	29	15	34	20	26	12	24.5	10.5

Note) When setting an auto switch, confirm the operation and adjust its mounting position.

Auto Switch Proper Mounting Position

Applicable Cylinders: MK2 Series

Auto switch model	D-M9□ D-M9□V D-M9□W D-M9□WV D-M9□AL D-M9□AVL		D-A9□ D-A9□V		D-A73 D-A80		D-A72/A7□H D-A80H/A73C D-A80C/F7□/F79F D-J79/F7□V/J79C D-F7BA□/F7□W D-J79W/F7□WV		D-F7NTL		D-A79W		D-P4DWL	
	A	B	A	B	A	B	A	B	A	B	A	B	A	B
Bore size 20	30	8	26	4	28.5	6.5	29	7	34	12	26	4	—	—
25	31	10	27	6	29.5	8.5	30	9	34.5	14	27	6	—	—
32	36	13	32	9	33	10	33.5	10.5	38	15.5	30.5	7.5	—	—
40	27	16	23	12	24	13	24.5	13.5	29	18.5	21.5	10.5	20	9
50	31	19.5	27	15.5	28	16.5	28.5	17	33.5	22	25.5	14	24	12.5
63	31.5	22.5	27.5	18.5	28.5	19.5	29	20	34	25	26	17	24.5	15.5

Note) When setting an auto switch, confirm the operation and adjust its mounting position.

Operating Range

Auto switch model	Bore size (mm)							
	12	16	20	25	32	40	50	63
D-M9□/M9□V	2	2.5	3.5	3.5	4	4	4	5
D-M9□W/M9□WV D-M9□AL/M9□AVL	3	4	4.5	5	6.5	5.5	6.5	6.5
D-A9□/A9□V	6	7.5	10	10	9.5	9.5	9.5	11.5
D-F7□/J79 D-F7□V/J79C D-F7□W/F7□WV D-J79W D-F79F/F7BAL D-F7BAVL/F7NTL	—	—	5.5	5	6	6	6	6.5
D-A7□/A80 D-A7H/A80H D-A73C/A80C	—	—	12	12	12	11	10	12
D-A79W	—	—	13	13	13	14	14	16
D-P4DWL	—	—	—	—	—	5	5	5

* This is a guideline including hysteresis, not meant to be guaranteed. (Assuming approximately ±30% dispersion.)
There may be the case it would vary substantially depending on an ambient environment.
* Figures for models D-M9□(V), M9□W(V), M9□A(V)L, and A9□(V) with ø12 or ø16 (MK), or ø32 or more (MK, MK2), indicate the operating range when using the existing switch-mounting groove, without using switch mounting bracket BQ2-012.

Series MK/MK2

Auto Switch Mounting Bracket/Part No.

Auto switch mounting surface	Bore size (mm)				
	ø12, ø16	ø20, ø25	ø32, ø40, ø50	ø63	
Auto switch model	A, B, C side	Only on auto switch mounting rail side	Port side	A, B, C side	Port, A, B, C side
D-M9□ D-M9□V D-M9□W D-M9□WV D-M9□AL D-M9□AVL D-A9□ D-A9□V	No auto switch mounting bracket necessary.	①BQ-1 ②BQ-012 Two types of auto switch mounting bracket are used as a set. 	No auto switch mounting bracket necessary.	①BQ-2 ②BQ-012 Two types of auto switch mounting bracket are used as a set. 	No auto switch mounting bracket necessary.

Note 1) For ø32 to ø50 of each cylinder series, when mounting compact auto switches on one of the three sides other than the port side (above A, B, C side) in the figure above, a separate auto switch mounting bracket is necessary as shown in the table above, so please order one separately from the cylinder.

(Same case when mounting compact auto switches with the auto switch mounting rail, not using the compact auto switch mounting groove, for diameters ø63 to ø100.)

Example

MKA32-10R-M9BW 1 unit

BQ-2 2 pcs.

BQ-012 2 pcs.

Note 2) When the cylinder is shipped, an auto switch mounting bracket and an auto switch are included.

Auto switch model	Bore size (mm)					
	20	25	32	40	50	63
D-F7□/J79 D-F7□V D-J79C D-F7□W/J79W D-F7□WV D-F7BAL/F7BAVL D-F79F/F7NTL D-A7□/A80 D-A73C/A80C D-A7□H/A80H D-A79W	BQ-1		BQ-2			
D-P4DWL	—		BQP1-050			

Note) When the cylinder is shipped, an auto switch mounting bracket and an auto switch are included.

However, ø40 to ø63 with the D-P4DWL are assembled at the time of shipment.

[Mounting screws set made of stainless steel]

The set of stainless steel mounting screws (with nuts) described below is available and can be used depending on the operating environment. (Please order the auto switch spacer BQ-2, since it is not included.)

The "D-F7BAL/F7BAVL" switch is set on the cylinder with the stainless steel screws above when shipped.

When only a switch is shipped independently, the "BBA2" screw set is attached.

Detailed Contents of the Stainless Steel Mounting Screw Set

Part no.	Content			Applicable auto switch mounting bracket part no.	Applicable auto switch
	Description	Size	Qty.		
BBA2	Auto switch mounting screw	M3 x 8 ℓ	1	BQ-1	D-A7 D-A8 D-F7 D-J7
	Auto switch mounting screw	M3 x 10 ℓ	1	BQ-2	
	Auto switch mounting nut (Square nut)	M3	1	BQ-1	
	Auto switch mounting nut (Convex type)	M3	1	BQ-2	

Note) When using BQ-1, BBA2 may be used by itself.

When using BQ-2, BQ-2 and BBA2 should be used together as a set, and used in combination with the spacer (black resin material) and stainless steel screws.

Auto Switch Mounting Bracket Weight

Mounting bracket part no.	Weight (g)
BQ-1	1.5
BQ-2	1.5
BQ-012	5
BQP1-050	16

The following auto switches are applicable to other models than those listed in the "How to Order" section. For detailed specifications, refer to the "Best Pneumatics" catalogue.

Type	Model	Electrical entry	Features
Solid state switch	D-F7NV, F7PV, F7BV	Grommet (Perpendicular)	—
	D-F7NWV, F7BWV		Diagnostic indication (2-colour indication)
	D-F7BAVL		Water resistant
	D-F79, F7P, J79	Grommet (In-line)	—
	D-F79W, F7PW, J79W		Diagnostic indication (2-colour indication)
	D-F7BAL		Water resistant (2-colour indication)
	D-F7NTL		With timer
D-P4DWL		Magnetic field resistant	
Reed switch	D-A73	Grommet (Perpendicular)	—
	D-A80		Without indicator light
	D-A73H, A76H	Grommet (In-line)	—
	D-A80H		Without indicator light

* Pre-wired connectors are also available for solid state switches. For details, refer to the "Best Pneumatics" catalogue.

* Normally closed (NC = b contact), solid state switches (D-F9G/F9H type) are also available. For details, refer to the "Best Pneumatics" catalogue.

* The D-A7, A8, F7, and J7 cannot be mounted to ø12 and ø16 models.

Rotary Clamp Cylinder: Double Guide Type

Series **MK2T**

ø20, ø25, ø32, ø40, ø50, ø63

How to Order

MK2T B 20 - **10 R N** - **M9BW** -

Rotary clamp cylinder
Double guide type

Mounting bracket

B	Through-hole/Both ends tapped common (Standard)
G	Head end flange

* Mounting bracket is included, (but not assembled).

Bore size

20	20 mm	40	40 mm
25	25 mm	50	50 mm
32	32 mm	63	63 mm

Cylinder port

—	M thread	ø20, ø25
	Rc	
TN	NPT	ø32 to ø63
TF	G	

Clamp stroke

Symbol	Clamp stroke	Applicable bore size
10	10 mm	ø20 to ø40
20	20 mm	ø20 to ø63
50	50 mm	ø50 to ø63

Number of auto switches

—	2 pcs.
S	1 pc.

Auto switch type

—	Without auto switch (Built-in magnet)
---	---------------------------------------

* For applicable auto switch models, refer to the table below.

Body option

—	Standard (Female thread)
N	With arm

* Arms are included when shipped, (but not assembled).

Rotary direction (Unclamp → Clamp)

R	Clockwise
L	Counterclockwise

Made to Order
(Refer to page 20 and 40.)

Applicable Auto Switches/Refer to page 29 through 39 for further information on auto switches.

Type	Special function	Electrical entry	Indicator/light	Wiring (Output)	Load voltage		Auto switch model				Lead wire length (m)					Pre-wired connector	Applicable load																																																																																																						
					DC	AC	Direct mounting		Rail mounting		0.5 (—)	1 (M)	3 (L)	5 (Z)	None (N)																																																																																																								
							ø20 to ø63	ø32 to ø63	Perpendicular	In-line								Perpendicular	In-line																																																																																																				
Solid state switch	—	Grommet	Yes	3-wire (NPN)	24 V	—	5 V, 12 V	—	—	—	—	●	—	●	○	—	○	IC circuit																																																																																																					
				3-wire (PNP)															—	—	—	—	—	●	—	●	○	—	○																																																																																										
		2-wire	—	—																										—	—	—	●	—	●	●	—	—																																																																																	
		—																																					—	—	—	—	—	●	—	●	●	—	—																																																																						
	Diagnostic indication (2-colour indication)	Grommet																																																Yes	3-wire (NPN)	5 V, 12 V	—	—	—	—	—	—	●	●	●	○	—	○	IC circuit																																																						
																																																			3-wire (PNP)															—	—	—	—	—	●	●	●	○	—	○																																											
	Water resistant (2-colour indication)	Grommet																																																Yes	2-wire																										12 V	—	—	—	—	—	—	●	—	●	○	—	○	IC circuit																													
																																																			3-wire (NPN)																																								—	—	—	—	—	○	○	●	○	—	○																		
	Diagnostic output (2-colour indication)	Grommet																																																Yes	3-wire (PNP)																																																			12 V	—	—	—	—	—	—	○	○	●	○	—	○	IC circuit				
																																																			2-wire																																																																	—	—	—	—
Magnetic field resistant (2-colour indication)	Grommet	Yes			4-wire	5 V, 12 V	—	—	—	—	—	—	●	—	●	○	—	○																																IC circuit																																																																					
					2-wire (No polarity)														—	—	—	—	—	—	—	●	—	●	—																						○																																																																				
Reed switch	—	Grommet	Yes	3-wire (NPN equivalent)	24 V																									—	5 V	—	—	—	—	●	—	●																																																																																	
				2-wire																																			—	—	—	—	—	—	—	—	—	—	—																																																																						
																																																				—	—	—	—	—	—	—	—	—	—																																																										
				Connector																																			No	Yes	—	200 V	100V	—	—	—	—	—	—			—										—	—	—	—	—																																																					
		Grommet	Yes																																						—												5 V, 12 V	100 V or less	—	—	—	—	—	—	—						—	—	—	—	IC circuit																																																
				Connector																																			No	Yes	—																															12 V	—	—	—	—	—	—	—	—	—	—	—	—																																			
		Grommet	Yes																																						—																																												5 V, 12 V	24 V or less	—	—	—	—	—	—	—	—	—	—	—	IC circuit																					
				Grommet																																			Yes	—	—																																																										—	—	—	—	—	—	—	—	—	—	—	—	—								
Grommet	Yes	—	—		—	—	—	—	—	—	—	—	—	—	—	—	—																																																																																																						
		Grommet		Yes														—	—	—	—	—	—	—	—	—	—	—	—	—	—	—																																																																																							

* Lead wire length symbols: 0.5 m — (Example) M9NW
 1 m M (Example) M9NWM
 3 m L (Example) M9NWL
 5 m Z (Example) M9NWZ
 None N (Example) J79CN

* Solid state switches marked with "○" are produced upon receipt of order.
 * For D-P4DW, ø40 to ø63 are available.
 * Only D-P4DW type is assembled at the time of shipment.

* Since there are other applicable auto switches than listed, refer to page 26 for details.
 * For details about auto switches with pre-wired connector, refer to page the "Best Pneumatics" catalogue.
 * Auto switches are included, (but not assembled).



Rotary Angle

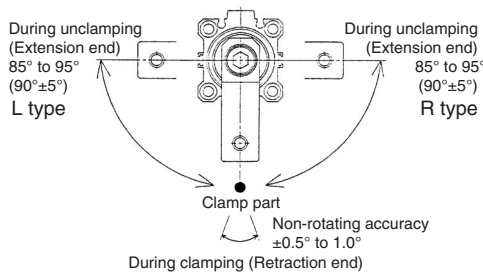

Made to Order

Symbol	Specifications
-XC89	Spatter resistant coil scraper, Lube-retainer, Grease for welding (Piston rod: S45C)
-XC91	Spatter resistant coil scraper, Grease for welding (Piston rod: S45C)



Made to Order
(For details, refer to page 40.)

Symbol	Description
X1859	With head end pin hole

Option/Arm

Bore size (mm)	Part no.	Accessories
20	MK-A020Z	Clamp bolt,
25		Hexagon socket head cap screw,
32	MK-A032Z	Hexagon nut,
40		Spring washer
50	MK-A050Z	
63	MK2T-A063	

Mounting Bracket/Flange

Bore size (mm)	Part no.	Accessories
20	CQS-F020	Hexagon socket head cap screw
25	CQS-F025	
32	MK2T-F032	
40	MK2T-F040	
50	MK2T-F050	
63	MK2T-F063	

Specifications

Bore size (mm)	20	25	32	40	50	63
Action	Double acting					
Rotation angle <small>Note 1)</small>	90° ±5°					
Rotary direction <small>Note 2)</small>	Clockwise, Counterclockwise					
Rotary stroke (mm)	19		29		33	
Clamp stroke (mm)	10, 20				20, 50	
Theoretical clamp force (N) <small>Note 3)</small>	100	185	300	525	825	1300
Fluid	Air					
Proof pressure	1.5 MPa					
Operating pressure range	0.1 to 1 MPa					
Ambient and fluid temperature	Without auto switch: -10 to 70°C (No freezing)					
	With auto switch: -10 to 60°C (No freezing)					
Lubrication	Non-lube					
Piping port size	M5 x 0.8		Rc1/8, NPT1/8, G1/8		Rc1/4, NPT1/4, G1/4	
Mounting	Through-hole/Both ends tapped common, Head end flange					
Cushion	Rubber bumper					
Stroke length tolerance	+1.0 0					
Piston speed	50 to 200 mm/s					
Non-rotating accuracy (Clamp part)	±1.0°			±0.5°		

Note 1) Refer to the "Rotary Angle" figure.

Note 2) Direction of rotation viewed from the rod end when the piston rod is retracting.

Note 3) At 0.5 MPa.

Theoretical Output

Unit: N

Bore size (mm)	Rod size (mm)	Operating direction	Piston area (cm ²)	Operating pressure (MPa)			
				0.3	0.5	0.7	1.0
20	12	R	2	60.8	100	139	200
		H	3	90.2	149	208	298
25	12	R	3.7	112	185	258	370
		H	4.9	149	245	341	490
32	16	R	6	182	300	418	600
		H	8	243	400	557	800
40	16	R	10.5	319	525	731	1050
		H	12.5	380	625	870	1250
50	20	R	16.5	502	825	1149	1648
		H	19.6	596	980	1365	1961
63	25	R	26	780	1300	1820	2600
		H	31.2	948	1560	2172	3121

Note) Theoretical output (N) = Pressure (MPa) x Piston area (cm²) x 100

Operating direction
R: Rod end (Clamp)
H: Head end (Unclamp)

Weight/Through-hole Mounting

Unit: g

Clamp stroke (mm)	Bore size (mm)					
	20	25	32	40	50	63
10	367	448	806	1008	—	—
20	433	520	914	1127	2049	2609
50	—	—	—	—	2672	3354

Additional Weight

Unit: g

Bore size (mm)	20	25	32	40	50	63
With arm	100	100	200	200	350	600
Head end flange (including mounting bolt)	133	153	166	198	345	531

Calculation: (Example) MK2TG20-10RN

- Standard calculation: MK2TB20-10R 367 g
- Extra weight calculation: Head end flange 133 g
- With arm 100 g
- 600 g

Series MK2T

Construction

MK2T□20 to 63

With arm (N)

Head end flange (G)

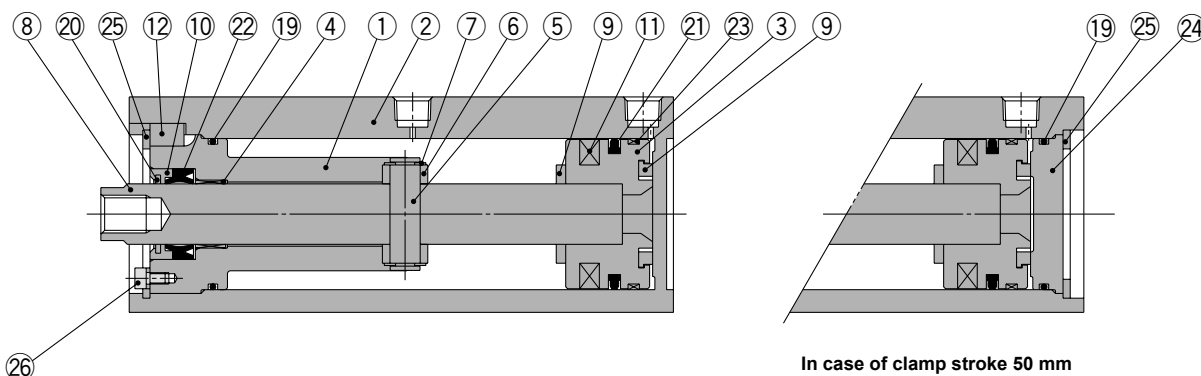
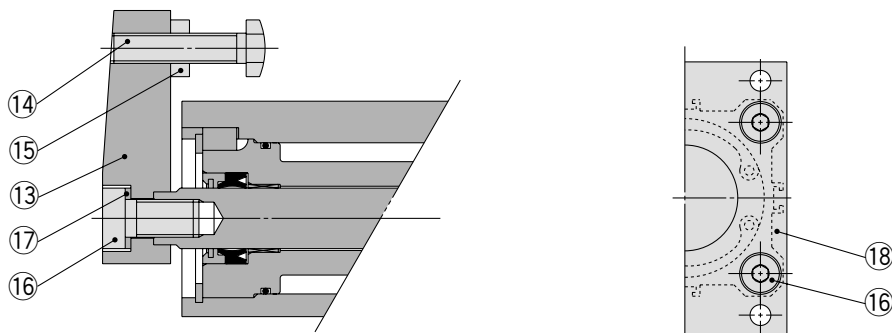

Component Parts

No.	Description	Material	Note
1	Rod cover	Structural steel	Electroless nickel plated
2	Cylinder tube	Aluminium alloy	Anodic oxide coating
3	Piston	Aluminium alloy	Trivalent chromated
4	Bushing	Oil-impregnated sintered alloy	ø20, ø25
		Bronze casted	ø32 to ø63
5	Guide shaft	Stainless steel	ø20, ø25: Hard chrome plated
		Structural steel	ø32 to ø63: Hard chrome plated
6	Guide roller	Structural steel	
7	Retaining ring	Steel for special applications	ø20, ø25: Phosphate coating ø32 to ø63: Zinc trivalent chromated
8	Piston rod	Stainless steel	ø20, ø25: Hard chrome plated
		Structural steel	ø32 to ø63: Hard chrome plated
9	Bumper	Urethane	
10	Seal retainer	Aluminium alloy	Trivalent chromated
11	Magnet	—	
12	Key	Structural steel	Zinc trivalent chromated

Component Parts

No.	Description	Material	Note
13	Arm	Structural steel	Electroless nickel plated
14	Clamp bolt	Structural steel	Electroless nickel plated
15	Hexagon nut	Structural steel	Nickel plated
16	Hexagon socket head cap screw	Structural steel	Nickel plated
17	Spring washer	Steel wire	Nickel plated
18	Flange	Structural steel	Nickel plated
19	Gasket	NBR	
20	Coil scraper	Bronze	
21	Piston seal	NBR	
22	Rod seal	NBR	
23	Wear ring	Resin	
24	Bottom plate	Aluminium alloy	Anodic oxide coating
25	Retaining ring	Steel for special applications	Phosphate coating
26	Hexagon socket head cap screw (with SW)	Structural steel	Nickel plated (ø40 to ø63 only)
	Washer	Stainless steel	ø25, ø32 only
	Hexagon socket head cap screw	Structural steel	Nickel plated (ø25, ø32 only)

Replacement Parts: Seal Kit

Bore size (mm)	20	25	32	40	50	63
Kit no.	MK2T20-PS	MK2T25-PS	MK2T32-PS	MK2T40-PS	MK2T50-PS	MK2T63-PS
Content	Set of nos. above 19 20 21 22					

* Seal kit includes 19, 20, 21, 22. Order the seal kit, basing on each bore size.

⚠️ Precautions

Be sure to read this before handling. Refer to back page 1 for Safety Instructions and "Precautions for Handling Pneumatic Devices" (M-03-E3A) for Common Precautions.

⚠️ Caution

Clamp Arm Mounting

- Use a clamp arm that is available as an option. To fabricate a clamp arm, make sure that the allowable bending moment and the inertial moment are within the specified range. If a clamp arm that exceeds the specified value is installed, the internal mechanism in the cylinder could become damaged.

Ensuring Safety

- If one side of the piston is pressurised by supplying air with the clamp arm attached, the piston will move vertically while the clamp arm rotates. This operation could be hazardous to personnel, as their hands or feet could get caught by the clamp arm, or could lead to equipment damage. Therefore, it is important to secure as a danger zone a cylindrical area with the length of the clamp arm as its radius, and the stroke plus 20 mm as its height.

Installation and Adjustment/ Clamp Arm Removal and Reinstallation

- During the removal or reinstallation of the clamp arm, make sure to use a wrench or a vise to secure the clamp arm before removing or tightening the bolt. This is to prevent the bolt tightening torque from being applied to the piston rod, which could damage the cylinder's internal mechanism.

Mounting Bolt for MK2TB

Mounting: Mounting bolt for through-hole type is available.

Ordering: Add the word "MK2TB" to the mounting bolt size.

Example) **M5 x 115 L (MK2TB) 4 pcs.**

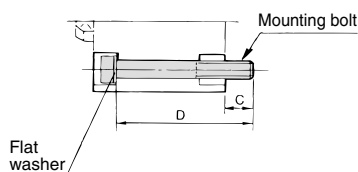

Note) Be sure to use a flat washer to mount cylinders via through-holes.

Cylinder model	C	D	Mounting bolt size
MK2TB20-10	11	115	M5 x 115 L
MK2TB20-20	11	135	M5 x 135 L
MK2TB25-10	8.5	115	M5 x 115 L
MK2TB25-20	8.5	135	M5 x 135 L
MK2TB32-10	11.5	145	M5 x 145 L
MK2TB32-20	11.5	165	M5 x 165 L
MK2TB40-10	7.5	145	M5 x 145 L
MK2TB40-20	7.5	165	M5 x 165 L
MK2TB50-20	13.5	185	M6 x 185 L
MK2TB50-50	10	245	M6 x 245 L
MK2TB63-20	13	185	M8 x 185 L
MK2TB63-50	14	250	M8 x 250 L

Precautions for Designing and Mounting Arms

When arms are to be made separately, their length and weight should be within the following range.

1. Allowable bending moment

Use the arm length and operating pressure in Graph (1) to select an allowable bending moment loaded piston rod.

Graph (1)

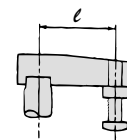
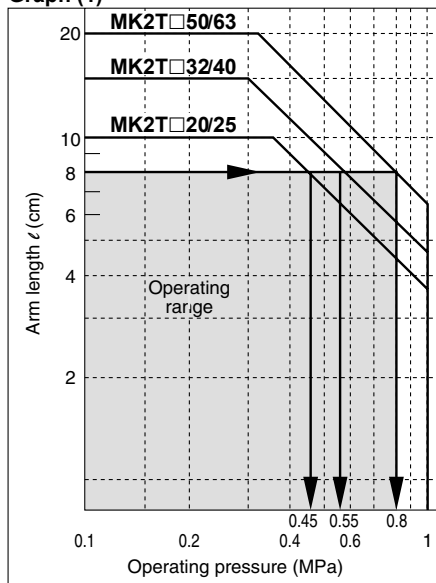

When the arm length is 8 cm, pressure should be less than
 MK2T□20/25: 0.45 MPa
 MK2T□32/40: 0.55 MPa
 MK2T□50/63: 0.8 MPa.

2. Moment of inertia

When the arm is long and heavy, damage of internal parts may be caused due to inertia. Use the inertia moment and cylinder speed in Graph (2) basing on the arm requirements.

Graph (2)

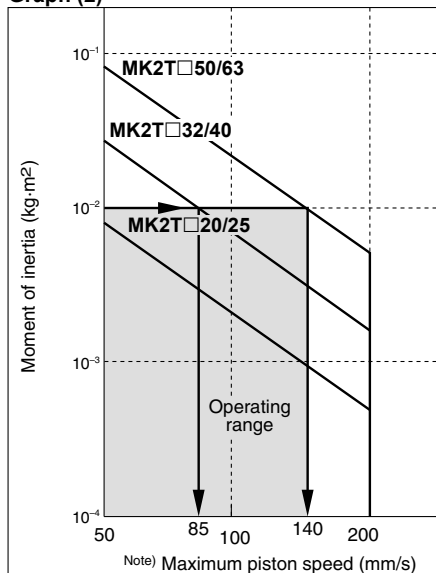

When the arm's moment of inertia is 1×10^{-2} kg·m², the cylinder speed should be less than
 MK2T□32/40: 85 mm/s
 MK2T□50/63: 140 mm/s.
 For calculating the moment of inertia, refer to front matter 1, 2, back page 8.

Note) The maximum piston speed is equivalent to approximately 1.6x the average piston speed. (Rough indication)

- To attach and detach the arm to and from the piston rod, fix the arm with a wrench or vise and then tighten the bolt.

(If an excessive force is applied in the rotary direction, it may cause damage to the internal mechanism.)

Refer to the following table for the tightening torque for mounting.

Bore size (mm)	Proper tightening torque (N·m)
20, 25	4 to 6
32, 40	8 to 10
50	14 to 16
63	106 to 127

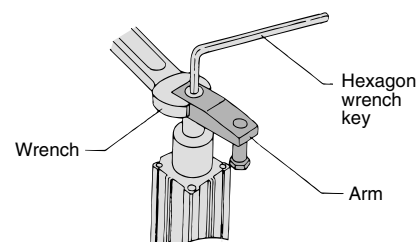

Series MK2T

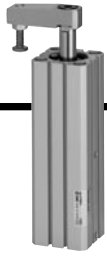

Dimensions: $\phi 20$, $\phi 25$

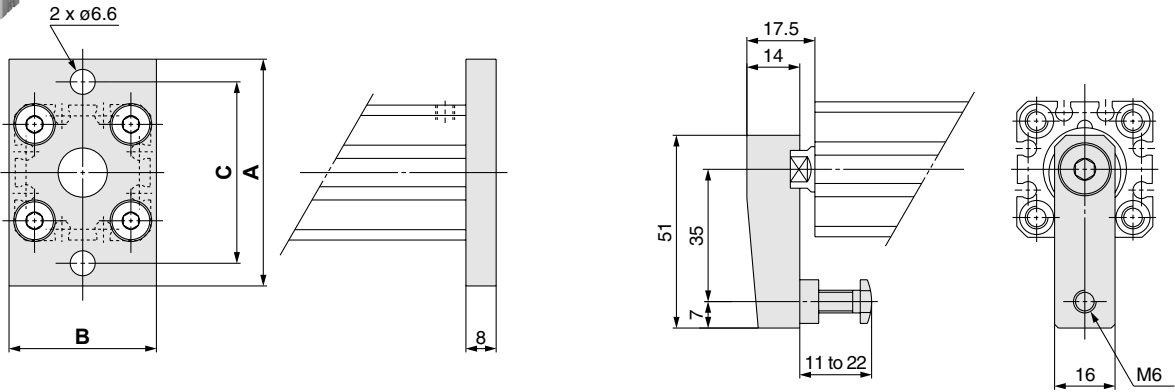

Head End Flange (mm)

Model	A	B	C
MK2TG20	60	39	48
MK2TG25	64	42	52

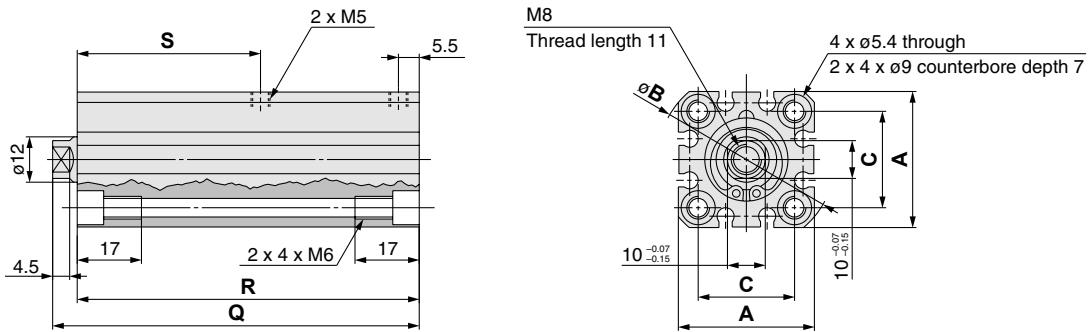

Through-hole/Both Ends Tapped Common (Standard) (mm)

Bore size	A	ϕB	C	Clamp stroke 10 mm			Clamp stroke 20 mm		
				Q	R	S	Q	R	S
20	36	47	25.5	116.5	110.5	59	136.5	130.5	69
25	40	52	28	119	113	59	139	133	69

Rotary Clamp Cylinder: Double Guide Type **Series MK2T**



Dimensions: $\varnothing 32$, $\varnothing 40$, $\varnothing 50$, $\varnothing 63$

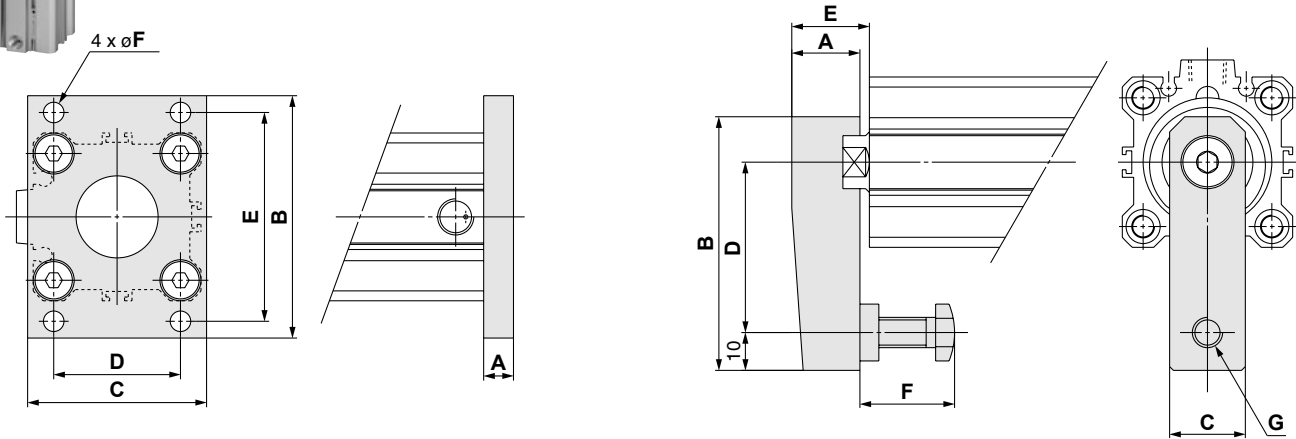

Head End Flange

(mm)

Model	A	B	C	D	E	$\varnothing F$
MK2TG32	8	65	48	34	56	5.5
MK2TG40	8	72	54	40	62	5.5
MK2TG50	9	89	67	50	76	6.6
MK2TG63	9	108	80	60	92	9

With Arm

(mm)

Model	A	B	C	D	E	F	G
MK2T□32□-□□N	18	67	20	45	21.5	15 to 25	M8
MK2T□40□-□□N	18	67	20	45	21	15 to 25	M8
MK2T□50□-□□N	22	88	22	65	29.5	20 to 40	M10
MK2T□63□-□□N	32	91	32	65	34.5	20 to 40	M10

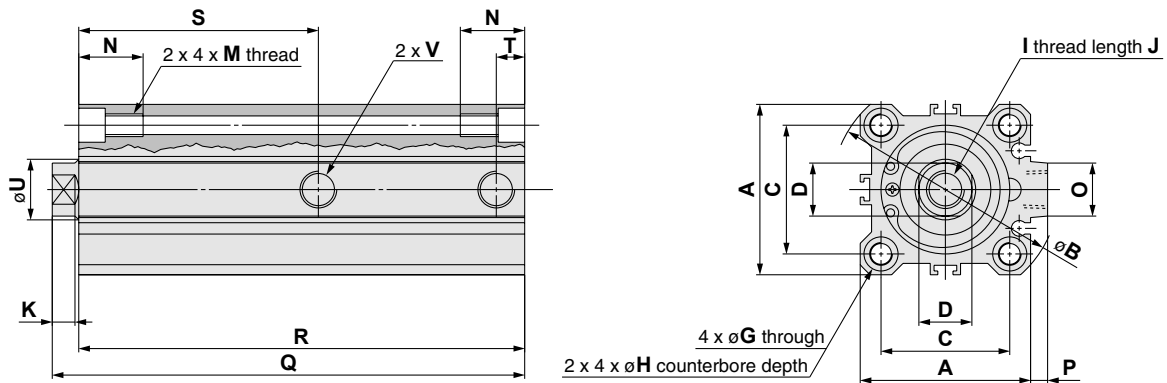

Through-hole/Both Ends Tapped Common (Standard)

(mm)

Bore size	A	$\varnothing B$	C	D	G	H	I	J	K	M	N	O	P	$\varnothing U$	V		
															Nil	TN	TF
32	45	60	34	14 ^{-0.07} _{-0.15}	5.5	9 depth 7	M10	12	6	M6	17	14	4.5	16	Rc1/8	NPT1/8	G1/8
40	52	69	40	14 ^{-0.07} _{-0.15}	5.5	9 depth 7	M10	12	6	M6	17	14	5	16	Rc1/8	NPT1/8	G1/8
50	64	86	50	17 ^{-0.07} _{-0.15}	6.6	11 depth 8	M12	15	7	M8	22	19	7	20	Rc1/4	NPT1/4	G1/4
63	77	103	60	22 ^{-0.07} _{-0.15}	9	14 depth 10.5	M16	21	8	M10	28.5	19	7	25	Rc1/4	NPT1/4	G1/4

Bore size	Clamp stroke 10 mm				Clamp stroke 20 mm				Clamp stroke 50 mm			
	Q	R	S	T	Q	R	S	T	Q	R	S	T
32	148	140	74	7.5	168	160	84	7.5	—	—	—	—
40	151.5	144	75	8	171.5	164	85	8	—	—	—	—
50	—	—	—	—	191	179	91.5	12.5	254.5	242.5	121.5	14
63	—	—	—	—	192	182	93	10.5	256	246	123	15

Series MK2T

Auto Switch Proper Mounting Position (Detection at Stroke End)

ø20 to ø63

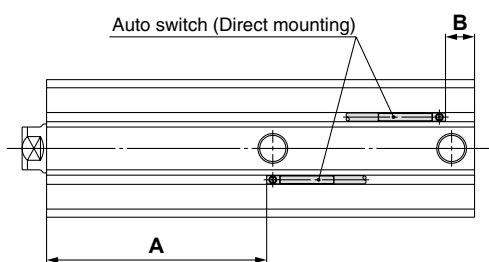

ø32 to ø63

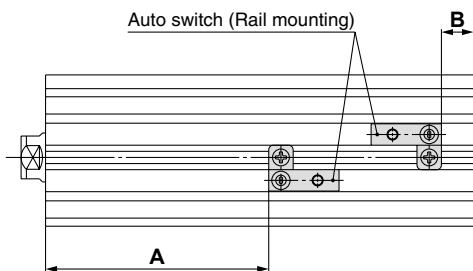

Mounting	Rail mounting								Direct mounting					
	D-A7 D-A8		D-A7□H/A80H D-A73C/A80C D-F7□/F79F/J79 D-F7□V/J79C D-F7BA□/F7□W D-J79W/F7□WV		D-A79W		D-P4DWL		D-M9□ D-M9□V D-M9□W D-M9□WV D-M9□AL D-M9□AVL		D-A9□ D-A9□V		D-F7NTL	
	A	B	A	B	A	B	A	B	A	B	A	B	A	B
MK2T20	—	—	—	—	—	—	—	—	60.5	9	56.5	5	63	11.5
MK2T25	—	—	—	—	—	—	—	—	61	11	57	7	63.5	13.5
MK2T32	73 (73.5)	10.5 (11)	73.5	11	70.5	8	—	—	76	13.5	72	9.5	78.5	16
MK2T40	74 (74.5)	13 (13.5)	74.5	13.5	71.5	10.5	70	9	77	16	73	12	79.5	18.5
MK2T50-20st	89.5 (90)	18.5 (19)	90	19	87	16	85.5	14.5	92.5	21.5	88.5	17.5	95	24
MK2T50-50st	119.5 (120)	22 (22.5)	120	22.5	117	19.5	115.5	18	122.5	25	118.5	21	125	27.5
MK2T63-20st	91.5 (92)	19.5 (20)	92	20	89	17	87.5	15.5	94.5	22.5	90.5	18.5	97	25
MK2T63-50st	121.5 (122)	23.5 (24)	122	24	119	21	117.5	19.5	124.5	26.5	120.5	22.5	127	29

* (): D-A72

Note) When setting an auto switch, confirm the operation and adjust its mounting position.

Operating Range

Operating Range (Dimensions)

(mm)

Auto switch model	Bore size					
	20	25	32	40	50	63
D-M9□/M9□V	—	—	4.5	4.5	5	5
D-M9□W/M9□WV D-M9□AL/M9□AVL	—	—	6.5	5.5	6.5	6.5
D-A9□/A9□V	9	9.5	9	9.5	9.5	11
D-F7□/J79 D-F7□V/F79F/J79C D-F7□W/F7□WV D-F79F/F7BAL/F7BAVL/F7NTL	—	—	6	6	6	6.5
D-A7□/A80 D-A7H/A80H D-A73C/A80C	—	—	9.5	11.5	11	13.5
D-A79W	—	—	6	7	7	9.5
D-P4DWL	—	—	—	5	5	5

* This is a guideline including hysteresis, not meant to be guaranteed.

(Assuming approximately ±30% dispersion.)

It could vary substantially depending on the ambient environment

The following auto switches are applicable to other models than those listed in the "How to Order" section. For detailed specifications, refer to the "Best Pneumatics" catalogue.

Type	Model	Electrical entry	Features	Applicable bore size
Solid state switch	D-F7NTL	Grommet (In-line)	With timer	ø32 to ø63
	D-F7BAVL	Grommet (Perpendicular)	Water resistant	
	D-F7BAL	Grommet (In-line)		
	D-P5DWL	Grommet (In-line)	Magnetic field resistant	
Reed switch	D-A80	Grommet (Perpendicular)	Without indicator light	ø32 to ø63
	D-A80H	Grommet (In-line)		
	D-A80C	Connector (Perpendicular)		
	D-A90	Grommet (In-line)		ø20 to ø63
	D-A90V	Grommet (Perpendicular)		

* Pre-wired connectors are also available for solid state switches. For details, refer to the "Best Pneumatics" catalogue.

* Normally closed (NC = b contact), solid state switches (D-F9G/F9H type) are also available. For details, refer to the "Best Pneumatics" catalogue.

Auto Switch Mounting Bracket/Part No.

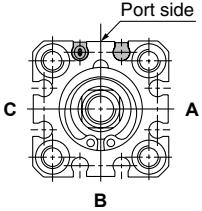
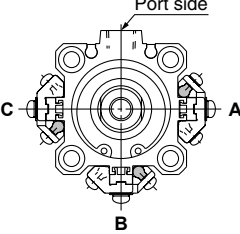
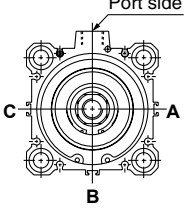
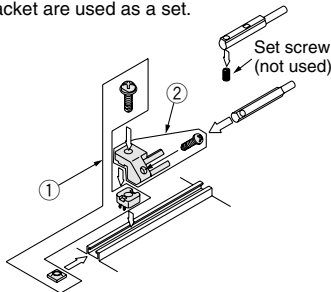
Auto switch mounting surface	Bore size (mm)		
	ø20, ø25	ø32, ø40, ø50	ø63
			
Auto switch model	Auto switch mounting surface A, B, C side	Port side	Auto switch mounting surface A, B, C side
	No auto switch mounting bracket necessary.	No auto switch mounting bracket necessary.	①BQ-2 ②BQ2-012 Two types of auto switch mounting bracket are used as a set. 
D-A9 □ D-A9 □V D-M9 □ D-M9 □V D-M9 □W D-M9 □WV D-M9 □AL D-M9 □AVL			No auto switch mounting bracket necessary.

Note 1) For ø32 to ø50 of each cylinder series, when mounting compact auto switches on one of the three sides other than the port side (above A, B, C side) in the figure above, a separate auto switch mounting bracket is necessary as shown in the table above, so please order one separately from the cylinder.
 (Same case when mounting compact auto switches with the auto switch mounting rail, not using the compact auto switch mounting groove, for diameters ø63.)

Example

MK2TB32-10R-M9BW 1 unit
 BQ-2 2 pcs.
 BQ2-012 2 pcs.

Note 2) When the cylinder is shipped, an auto switch mounting bracket and an auto switch are included.

Auto switch model	Bore size (mm)			
	32	40	50	63
D-A7 □/A80 D-A73C/A80C D-A7 □H/A80H D-A79W D-F7 □/J79 D-F7 □V D-J79C D-F7 □W/J79W D-F7 □WV D-F7BAL/F7BAVL D-F79F/F7NTL				BQ-2
D-P4DWL	—			BQP1-050

Note) When the cylinder is shipped, an auto switch mounting bracket and an auto switch are included.
 However, ø40 to ø63 D-P4DWL are assembled at the time of shipment.

[Mounting screws set made of stainless steel]

The set of stainless steel mounting screws (with nuts) described below is available and can be used depending on the operating environment. (Please order the auto switch spacer BQ-2, since it is not included.)

"D-F7BAL/F7BAVL" switch is set on the cylinder with the stainless steel screws above when shipped.

When only a switch is shipped independently, the "BBA2" screws are attached.

Detailed Contents of the Stainless Steel Mounting Screw Set

Part no.	Content			Applicable auto switch mounting bracket part no.	Applicable auto switch
	Description	Size	Qty.		
BBA2	Auto switch mounting screw	M3 x 8 ℓ	1	BQ-1	D-A7 D-A8 D-F7 D-J7
		M3 x 10 ℓ	1	BQ-2	
	Auto switch mounting nut (Square nut)	M3	1	BQ-1	
	Auto switch mounting nut (Convex type)	M3	1	BQ-2	

Note) When using BQ-1, BBA2 may be used by itself.

When using BQ-2, BQ-2 and BBA2 should be used together as a set, and used in combination with the spacer (black resin material) and stainless steel screws.

Auto Switch Mounting Bracket Weight

Mounting bracket part no.	Weight (g)
BQ-1	1.5
BQ-2	1.5
BQ2-012	5
BQP1-050	16

Series MK/MK2/MK2T

Auto Switch Specifications

Auto Switch Common Specifications

Type	Reed switch	Solid state switch
Leakage current	None	3-wire: 100 μ A or less 2-wire: 0.8 mA or less
Operating time	1.2 ms	1 ms or less *2)
Impact resistance	300 m/s ²	1000 m/s ²
Insulation resistance	50 M Ω or more at 500 VDC Mega (between lead wire and case)	
Withstand voltage	1500 VAC for 1 minute (between lead wire and case) *1)	1000 VAC for 1 minute (between lead wire and case)
Ambient temperature	-10 to 60°C	
Enclosure	IEC60529 standard IP67, JIS C 0920 waterproof construction	
Standards	Conforming to CE standards	

*1) For connector type D-A73C and A80C, 1000 VAC for 1 minute (between lead wire and case).

*2) Except solid state switch with timer D-F7NLT, and magnetic field resistant 2-colour indication solid state switch D-P4DWL.

Lead Wire Length

Lead wire length indication

(Example) **D-M9BW** **L**

Lead wire length

—	0.5 m
M	1 m
L	3 m
Z	5 m

Note 1) Applicable auto switch with 5 m lead wire "Z"

Solid state switch: Manufactured upon receipt of order as standard.

Note 2) To designate solid state switch with flexible specifications, add "-61" after the lead wire length. Flexible cable is used for the D-M9□(V), D-M9□W(V), D-M9□A(V), D-M9□A(V) as standard. There is no need to place the suffix -61 to the end of part number.

(Example) **D-F79F-61**

Flexible specification

Note 3) 1 m (M): D-M9□W, D-M9□A(V)

Lead Wire Part No. with Connector (applicable to connector type only)

Model	Lead wire length	Standard/Flexible
D-LC05	0.5 m	Standard
D-LC30	3.0 m	Standard
D-LC50	5.0 m	Standard

Contact Protection Box: CD-P11/CD-P12

<Applicable switch model>

D-A9/A9□V, A7□(H)(C), A80(H)(C), A79W type

The above auto switch type does not have a built-in contact protection circuit.

① Where the operation load is an inductive load.

② Where the wiring length to load is greater than 5 m.

③ Where the load voltage is 100/200 VAC.

Therefore, use a contact protection box with the switch for any of the above cases:

The contact life may be shortened (due to permanent energising conditions).

④ Where the load voltage is 110 VAC.

When the load voltage is increased by more than 10% to the rating of applicable auto switches (except D-A73C/A80C/A79W) above, use a contact protection box (CD-P11) to reduce the upper limit of the load current by 10% so that it can be set within the range of the load current range, 110 VAC.

Specifications

Part no.	CD-P11		CD-P12
Load voltage	100 VAC	200 VAC	24 VDC
Max. load current	25 mA	12.5 mA	50 mA

* Lead wire length — Switch connection side 0.5 m
Load connection side 0.5 m



Internal Circuit

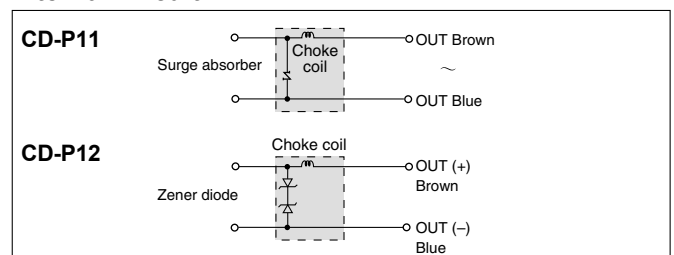

Dimensions

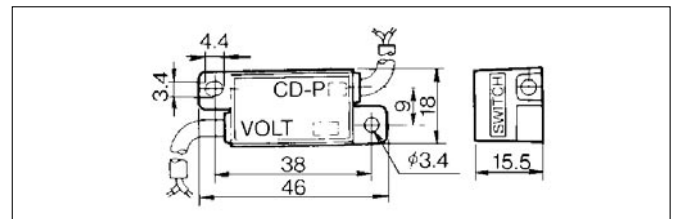

Connection

To connect a switch unit to a contact protection box, connect the lead wire from the side of the contact protection box marked SWITCH to the lead wire coming out of the switch unit. Keep the switch as close as possible to the contact protection box, with a lead wire length of no more than 1 meter.

Auto Switch Connections and Examples

Basic Wiring

Solid state 3-wire, NPN

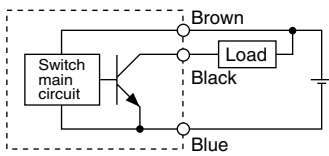

Solid state 3-wire, PNP

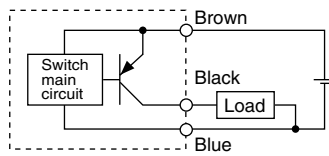

2-wire (Solid state)

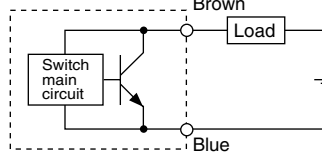

2-wire (Reed)

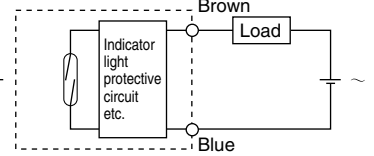

(Power supplies for switch and load are separate.)

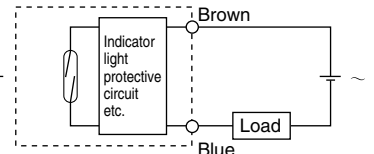
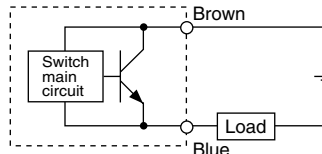
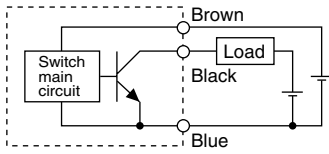

Example of Connection to PLC (Programmable Logic Controller)

• Sink input specification 3-wire, NPN

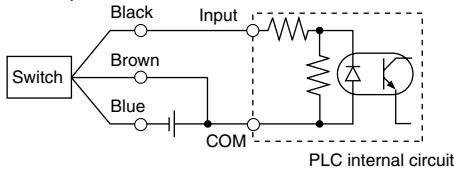

• Source input specification 3-wire, PNP

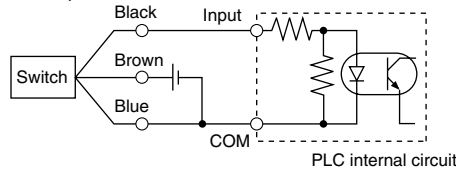

Connect according to the applicable PLC input specifications, since the connection method will vary depending on the PLC input specifications.

2-wire

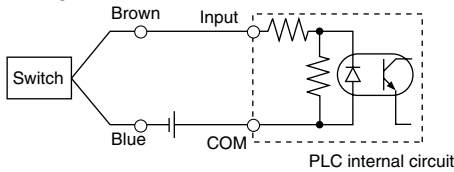

2-wire

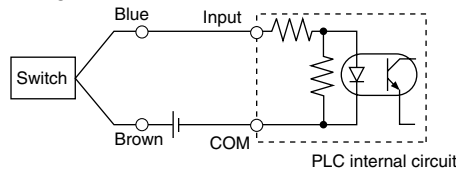

Example of AND (Serial) and OR (Parallel) Connection

• 3-wire

AND connection for NPN output (using relays)

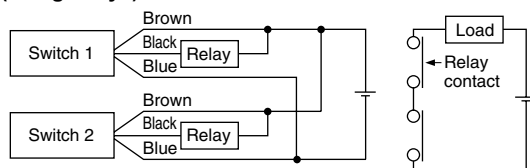

AND connection for NPN output (performed with switches only)

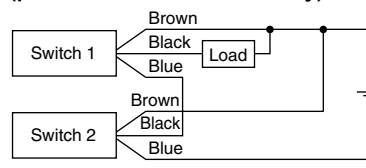

OR connection for NPN output

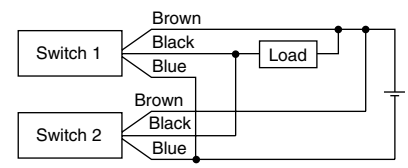

The indicator lights will illuminate when both switches are turned ON.

2-wire with 2-switch AND connection

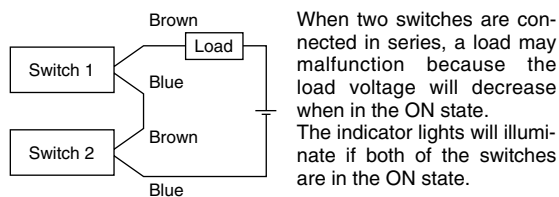

When two switches are connected in series, a load may malfunction because the load voltage will decrease when in the ON state. The indicator lights will illuminate if both of the switches are in the ON state.

$$\begin{aligned} \text{Load voltage at ON} &= \text{Power supply voltage} - \text{Residual voltage} \times 2 \text{ pcs.} \\ &= 24 \text{ V} - 4 \text{ V} \times 2 \text{ pcs.} \\ &= 16 \text{ V} \end{aligned}$$

Example: Power supply is 24 VDC.
Internal voltage drop in switch is 4 V.

2-wire with 2-switch OR connection

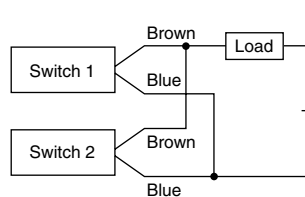

(Solid state)

When two switches are connected in parallel, a malfunction may occur because the load voltage will increase when in the OFF state.

$$\begin{aligned} \text{Load voltage at OFF} &= \text{Leakage current} \times 2 \text{ pcs.} \\ &\quad \times \text{Load impedance} \\ &= 1 \text{ mA} \times 2 \text{ pcs.} \times 3 \text{ k}\Omega \\ &= 6 \text{ V} \end{aligned}$$

Example: Load impedance is 3 kΩ.
Leakage current from switch is 1 mA.

(Reed)

Because there is no current leakage, the load voltage will not increase when turned OFF. However, depending on the number of switches in the ON state, the indicator lights may sometimes dim or not light because of the dispersion and reduction of the current flowing to the switches.

Reed Switch: Direct Mounting Style D-A90(V)/D-A93(V)/D-A96(V)

Grommet

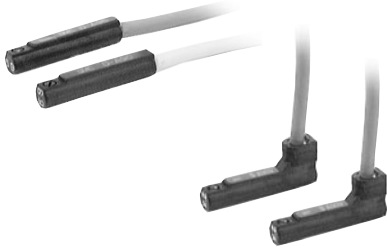

Caution

Precautions

Fix the switch with the existing screw installed on the switch body. The switch may be damaged if a screw other than the one supplied is used.

Auto Switch Internal Circuit

D-A90(V)

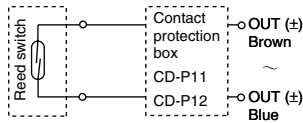

D-A93(V)

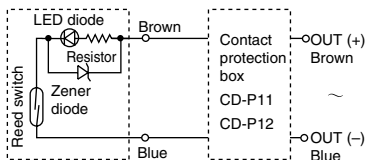

D-A96(V)

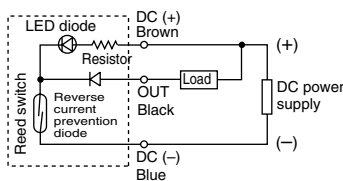

- Note) ① In case the operation load is an inductive load.
 ② In case the wiring load is greater than 5 m.
 ③ In case the load voltage is 100 VAC.

Use the auto switch with a contact protection box in any of the above mentioned cases. (For details about the contact protection box, refer to page 27.)

Auto Switch Specifications

PLC: Programmable Logic Controller

D-A90(V) (Without indicator light)						
Auto switch model	D-A90	D-A90V	D-A90	D-A90V	D-A90	D-A90V
Electrical entry direction	In-line	Perpendicular	In-line	Perpendicular	In-line	Perpendicular
Applicable load	IC circuit, Relay, PLC					
Load voltage	24 VAC/DC or less		48 VAC/DC or less		100 VAC/DC or less	
Maximum load current	50 mA		40 mA		20 mA	
Contact protection circuit	None					
Internal resistance	1 Ω or less (including lead wire length of 3 m)					
Standards	Conforming to CE standards					
D-A93(V)/D-A96(V) (With indicator light)						
Auto switch model	D-A93	D-A93V	D-A93	D-A93V	D-A96	D-A96V
Electrical entry direction	In-line	Perpendicular	In-line	Perpendicular	In-line	Perpendicular
Applicable load	Relay, PLC				IC circuit	
Load voltage	24 VDC		100 VAC		4 to 8 VDC	
Load current range and max. load current	5 to 40 mA		5 to 20 mA		20 mA	
Contact protection circuit	None					
Internal voltage drop	D-A93 — 2.4 V or less (to 20 mA)/3 V or less (to 40 mA) D-A93V — 2.7 V or less				0.8 V or less	
Indicator light	Red LED illuminates when turned ON.					
Standards	Conforming to CE standards					

Lead wires

D-A90(V)/D-A93(V) — Oilproof heavy-duty vinyl cable: $\phi 2.7$, 0.18 mm² x 2 cores (Brown, Blue), 0.5 m
 D-A96(V) — Oilproof heavy-duty vinyl cable: $\phi 2.7$, 0.15 mm² x 3 cores (Brown, Black, Blue), 0.5 m

Note 1) Refer to page 27 for reed switch common specifications.

Note 2) Refer to page 27 for lead wire lengths.

Weight

Unit: g

Auto switch model	D-A90(V)	D-A93(V)	D-A96(V)
Lead wire length (m)	0.5	6	8
	3	30	41

Dimensions

Unit: mm

D-A90/A93/A96

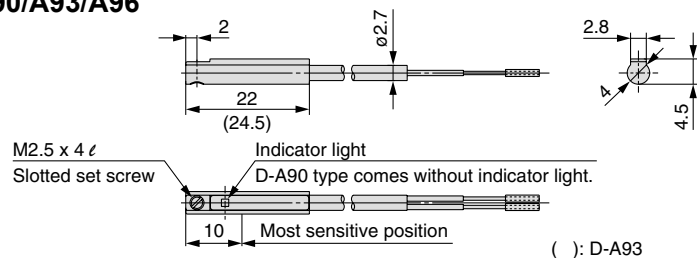

D-A90V/A93V/A96V

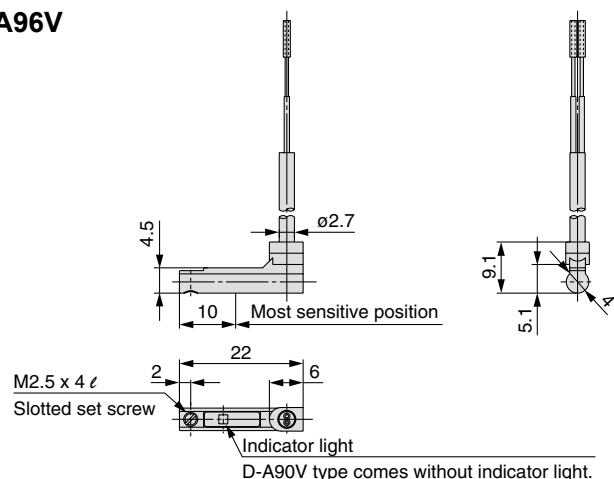

Reed Switch: Rail Mounting Style D-A72



Grommet
Electrical entry direction: Perpendicular



Auto Switch Specifications

PLC: Programmable Logic Controller

D-A72 (With indicator light)	
Auto switch model	D-A72
Applicable load	Relay, PLC
Load voltage	200 VAC
Load current range ^{Note 3)}	5 to 10 mA
Contact protection circuit	None
Internal resistance	2.4 V or less
Indicator light	Red LED illuminates when turned ON.
Standards	Conforming to CE standards

● Lead wires — Oilproof heavy-duty vinyl cable: $\phi 3.4$, $0.2 \text{ mm}^2 \times 2$ cores (Brown, Blue), 0.5 m

Note 1) Refer to page 27 for reed switch common specifications.

Note 2) Refer to page 27 for lead wire lengths.

Note 3) Under 5 mA, the strength of the indicator light is poor. In some cases, visibility of the indicator light is not be possible if the output signal is less than 2.5 mA. However, there is no problem in terms of contact output, if an output signal exceeds 1 mA or more.

Auto Switch Internal Circuit

D-A72

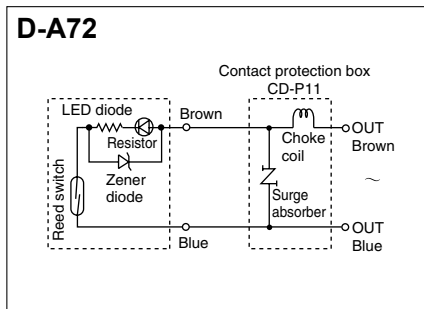

Note) For D-A72, be sure to use the contact protection box. (For details about the contact protection box, refer to page 27).

Weight

Unit: g

Auto switch model	D-A72	
Lead wire length (m)	0.5	10
	3	47
	5	—

Dimensions

Unit: mm

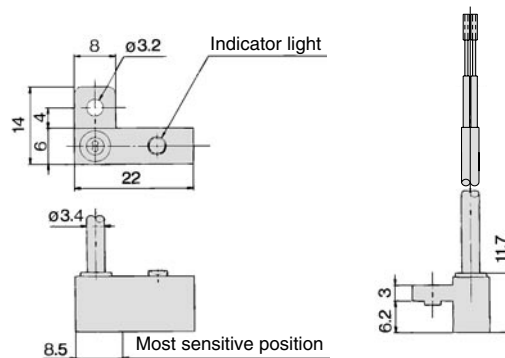

Reed Switch: Rail Mounting Style D-A72H



Grommet
Electrical entry direction: In-line



Auto Switch Internal Circuit

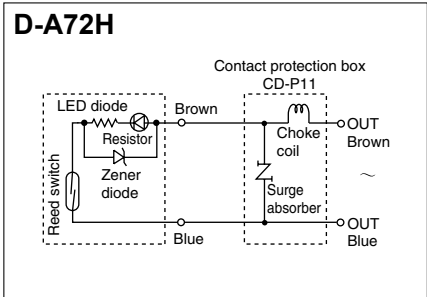

Note) For D-A72H, be sure to use the contact protection box. (For details about the contact protection box, refer to page 27.)

Auto Switch Specifications

PLC: Programmable Logic Controller

D-A72H (With indicator light)	
Auto switch model	D-A72H
Applicable load	Relay, PLC
Load voltage	200 VAC
Maximum load current and Load current range ^{Note 3)}	5 to 10 mA
Contact protection circuit	None
Internal resistance	2.4 V or less
Indicator light	Red LED illuminates when turned ON.
Standards	Conforming to CE standards

• Lead wires — Oilproof heavy-duty vinyl cable: 0.2 mm² x 2 cores (Brown, Blue), 0.5 m

Note 1) Refer to page 27 for reed switch common specifications.

Note 2) Refer to page 27 for lead wire lengths.

Note 3) Under 5 mA, the strength of the indicator light is poor. In some cases, visibility of the indicator light is not possible if the output signal is less than 2.5 mA. However, there is no problem in terms of contact output, if an output signal exceeds 1 mA or more.

Weight

Unit: g

Auto switch model	D-A72H	
Lead wire length (m)	0.5	10
	3	47
	5	—

Dimensions

Unit: mm

D-A7□H/A80H

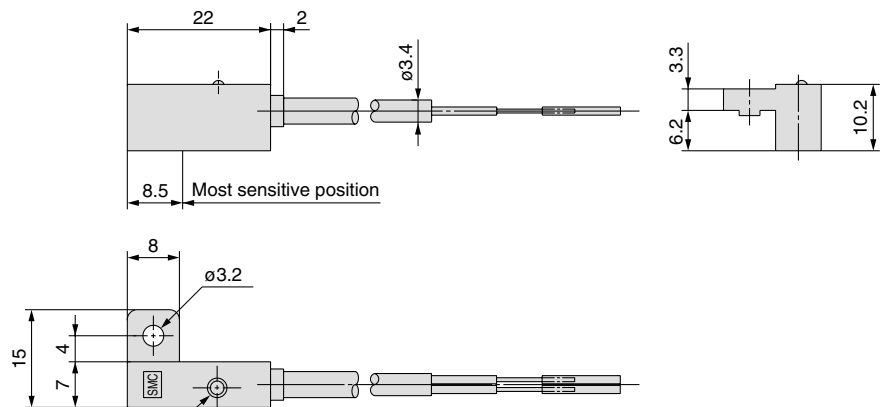

Indicator light
D-A80H type comes without indicator light.

Reed Switch: Rail Mounting Style D-A73C/D-A80C



Connector



Caution

Precautions

1. Confirm that the connector is appropriately tightened. If tightened insufficiently, the waterproof performance will deteriorate.
2. For how to handle a connector, refer to the figures below.

Auto Switch Internal Circuit

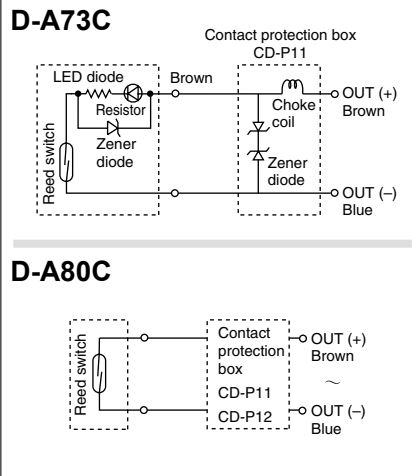

- Note) ① In case the operation load is an inductive load.
② In case the wiring load is greater than 5 m.

Use the auto switch with a contact protection box in any of the above mentioned cases. (For details about the contact protection box, refer to page 27.)

How to Insert the Connector

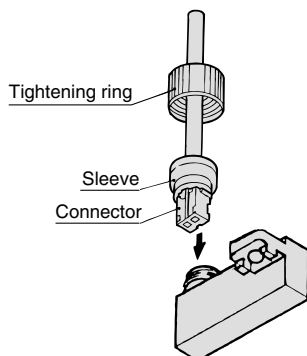

Turn the connector so it faces the direction shown in the figure, and after inserting it until the sleeve hits the auto switch, screw on the tightening ring. (Do not screw it on using pliers or other tools.)

Auto Switch Specifications

PLC: Programmable Logic Controller

D-A73C (With indicator light)	
Auto switch model	D-A73C
Applicable load	Relay, PLC
Load voltage	24 VDC
Load voltage ^{Note 4)}	5 to 40 mA
Contact protection circuit	None
Internal resistance	2.4 V or less
Indicator light	Red LED illuminates when turned ON.
Standards	Conforming to CE standards
D-A80C (Without indicator light)	
Auto switch model	D-A80C
Applicable load	Relay, IC circuit, PLC
Load voltage	24 VAC/DC
Maximum load current	50 mA
Contact protection circuit	None
Internal resistance	1 Ω or less (including lead wire length of 3 m)
Standards	Conforming to CE standards

- Lead wires — Oilproof heavy-duty vinyl cable: 3.4 mm² x 2 cores (Brown, Blue), 0.5 m

Note 1) Refer to page 27 for reed switch common specifications.

Note 2) Refer to page 27 for lead wire lengths.

Note 3) Lead wire with connector may be shipped attached to the switch.

Note 4) Under 5 mA, the strength of the indicator light is poor. In some cases, visibility of the indicator light is not possible if the output signal is less than 2.5 mA. However, there is no problem in terms of contact output, if an output signal exceeds 1 mA or more.

Weight

Unit: g

Auto switch model	D-A73C	D-A80C
Lead wire length (m)		
0.5	12	12
3	54	54
5	84	84

Dimensions

Unit: mm

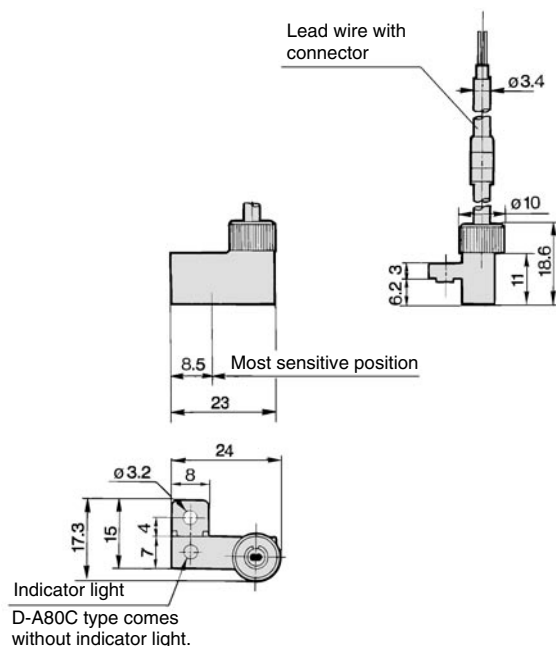

2-Colour Indication Solid State Switch: Rail Mounting Style D-A79W



Grommet

- The optimum operating position can be determined by the colour of the light. (Red → Green ← Red)



Auto Switch Internal Circuit

D-A79W

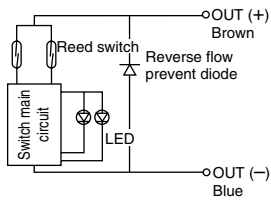

Indicator light / Display method

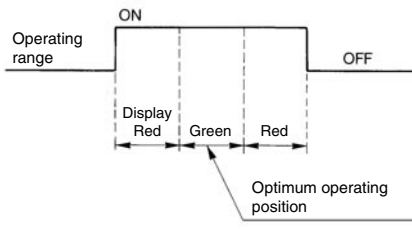

- Note) ① In case the operation load is an inductive load.
② In case the wiring load is greater than 5 m.

Use the auto switch with a contact protection box in any of the above mentioned cases. (For details about the contact protection box, refer to page 27.)

Auto Switch Specifications

PLC: Programmable Logic Controller

D-A79W (With indicator light)	
Auto switch model	D-A79W
Applicable load	Relay, PLC
Load voltage	24 VDC
Load current range ^{Note 3)}	5 to 40 mA
Contact protection circuit	None
Internal voltage drop	4 V or less
Indicator light	Operating position Red LED illuminates. Optimum operating position Green LED illuminates.
Standards	Conforming to CE standards

- Lead wires — Oilproof heavy-duty vinyl cable: $\phi 3.4$, $0.2 \text{ mm}^2 \times 2$ cores (Brown, Blue), 0.5 m

Note 1) Refer to page 27 for reed switch common specifications.

Note 2) Refer to page 27 for lead wire lengths.

Note 3) Under 5 mA, the strength of the indicator light is poor. In some cases, visibility of the indicator light is not possible if the output signal is less than 2.5 mA. However, there is no problem in terms of contact output, if an output signal exceeds 1 mA or more.

Weight

Unit: g

Auto switch model		D-A79W
Lead wire length (m)	0.5	11
	3	53
	5	—

Dimensions

Unit: mm

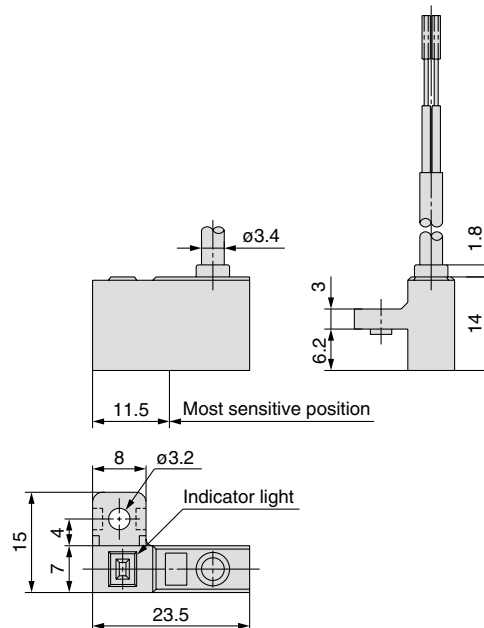

Solid State Switch: Direct Mounting Style D-M9N(V)/D-M9P(V)/D-M9B(V)

Grommet

- 2-wire load current is reduced (2.5 to 40 mA).
- UL certified (style 2844) lead cable is used.
- Flexibility is 1.5 times greater than the conventional model (SMC comparison).
- Using flexible cable as standard spec.



⚠ Caution

Precautions

Fix the switch with the existing screw installed on the switch body. The switch may be damaged if a screw other than the one supplied is used.

Auto Switch Internal Circuit

D-M9N(V)

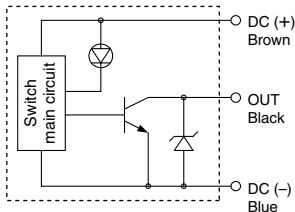

D-M9P(V)

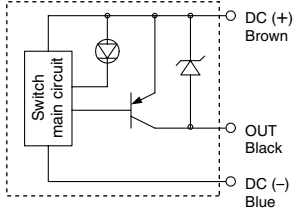

D-M9B(V)

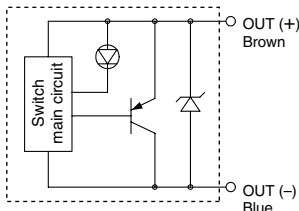

Auto Switch Specifications

PLC: Programmable Logic Controller

D-M9□(V) (With indicator light)						
Auto switch model	D-M9N	D-M9NV	D-M9P	D-M9PV	D-M9B	D-M9BV
Electrical entry direction	In-line	Perpendicular	In-line	Perpendicular	In-line	Perpendicular
Wiring type	3-wire				2-wire	
Output type	NPN		PNP		—	
Applicable load	IC circuit, Relay, PLC				24 VDC relay, PLC	
Power supply voltage	5, 12, 24 VDC (4.5 to 28 V)				—	
Current consumption	10 mA or less				—	
Load voltage	28 VDC or less		—		24 VDC (10 to 28 VDC)	
Load current	40 mA or less				2.5 to 40 mA	
Internal voltage drop	0.8 V or less				4 V or less	
Leakage current	100 μA or less at 24 VDC				0.8 mA or less	
Indicator light	Red LED illuminates when turned ON.					
Standards	Conforming to CE standards					

- Lead wires — Oilproof heavy-duty vinyl cable: $\phi 2.7 \times 3.2$ ellipse
 D-M9B(V) 0.15 mm² x 2 cores
 D-M9N(V), D-M9P(V) 0.15 mm² x 3 cores

Note 1) Refer to page 27 for solid state switch common specifications.

Note 2) Refer to page 27 for lead wire lengths.

Weight

Unit: g

Auto switch model	D-M9N(V)	D-M9P(V)	D-M9B(V)
Lead wire length (m)			
0.5	8	8	7
3	41	41	38
5	68	68	63

Dimensions

Unit: mm

D-M9□

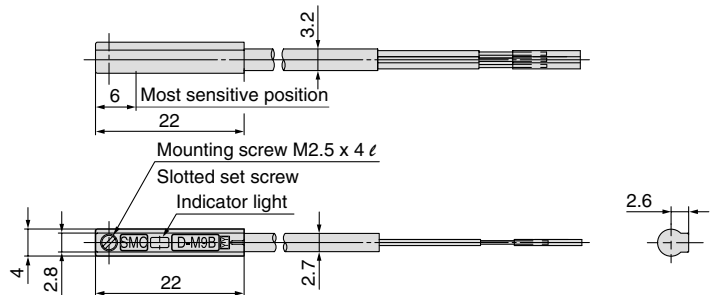

D-M9□V

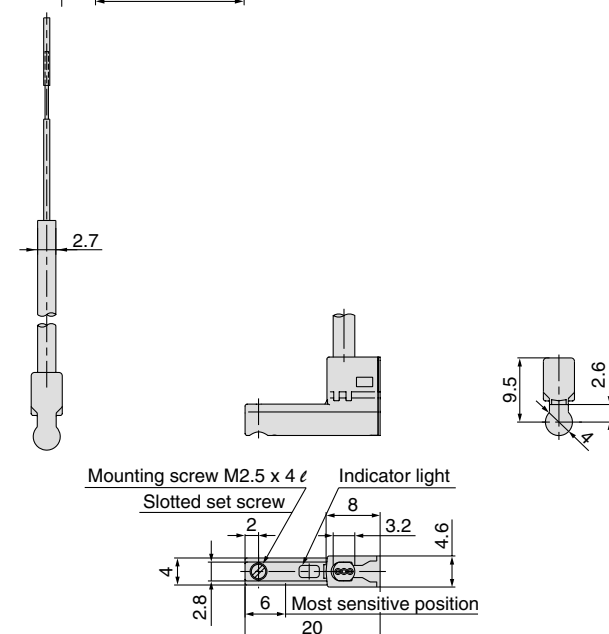

Solid State Switch: Rail Mounting Style D-J79C



Connector

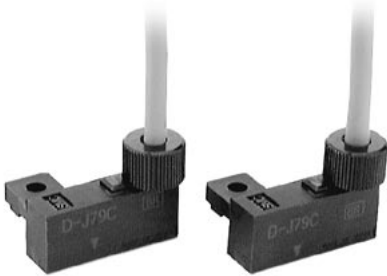

Caution

Precautions

1. Confirm that the connector is appropriately tightened. If tightened insufficiently, the waterproof performance will deteriorate.
2. For how to handle a connector, refer to the below figure.

Auto Switch Internal Circuit

D-J79C

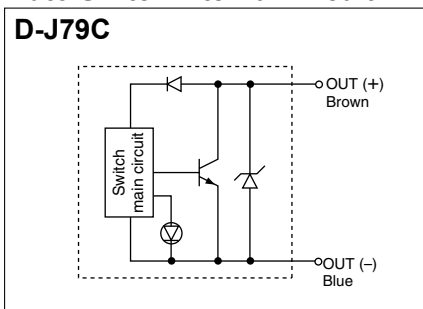

How to Insert the Connector

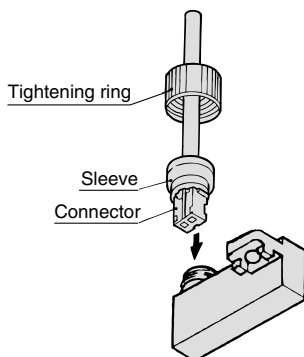

Turn the connector so it faces the direction shown in the figure, and after inserting it until the sleeve hits the auto switch, screw on the tightening ring.
(Do not screw it on using pliers or other tools.)

Auto Switch Specifications

PLC: Programmable Logic Controller

D-J79C	
Auto switch model	D-J79C
Wiring type	2-wire
Output type	—
Applicable load	24 VDC Relay, PLC
Power supply voltage	—
Current consumption	—
Load voltage	24 VDC (10 to 28 VDC)
Load current	5 to 40 mA
Internal voltage drop	4 V or less
Leakage current	0.8 mA or less at 24 VDC
Indicator light	Red LED illuminates when ON.
Standards	Conforming to CE standards

- Lead wires — Oilproof heavy-duty vinyl cable: $\phi 3.4$, $0.2 \text{ mm}^2 \times 2$ cores (Brown, Blue), 0.5 m
- Note 1) Refer to page 27 for solid state switch common specifications.
Note 2) Refer to page 27 for lead wire lengths and lead wire with connector.

Weight

Unit: g

Auto switch model		D-J79C
Lead wire length (m)	0.5	13
	3	52
	5	83

Dimensions

Unit: mm

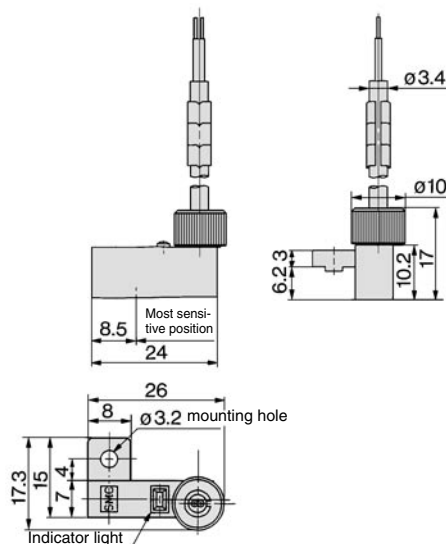

2-Colour Indication Solid State Switch: Direct Mounting Style

D-M9NW(V)/D-M9PW(V)/D-M9BW(V)

Grommet

- 2-wire load current is reduced (2.5 to 40 mA).
- UL certified (style 2844) lead cable is used.
- Flexibility is 1.5 times greater than the conventional model (SMC comparison).
- Using flexible cable as standard spec.
- The optimum operating position can be determined by the colour of the light. (Red → Green ← Red)



Auto Switch Internal Circuit

D-M9NW(V)

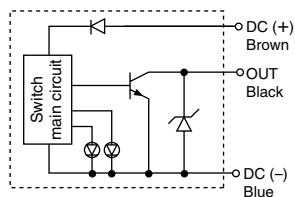

D-M9PW(V)

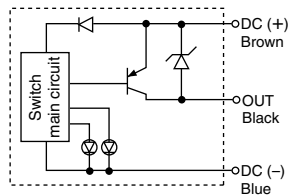

D-M9BW(V)

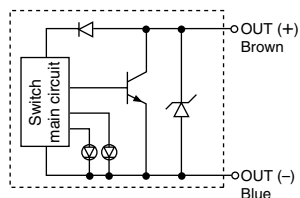

Indicator light / Display method

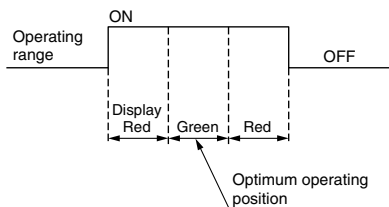

Auto Switch Specifications

PLC: Programmable Logic Controller

D-M9□W(V) (With indicator light)						
Auto switch model	D-M9NW	D-M9NWV	D-M9PW	D-M9PWV	D-M9BW	D-M9BWV
Electrical entry direction	In-line	Perpendicular	In-line	Perpendicular	In-line	Perpendicular
Wiring type	3-wire				2-wire	
Output type	NPN		PNP		—	
Applicable load	IC circuit, Relay, PLC				24 VDC relay, PLC	
Power supply voltage	5, 12, 24 VDC (4.5 to 28 V)				—	
Current consumption	10 mA or less				—	
Load voltage	28 VDC or less		—		24 VDC (10 to 28 VDC)	
Load current	40 mA or less				2.5 to 40 mA	
Internal voltage drop	0.8 V or less at 10 mA (2 V or less at 40 mA)				4 V or less	
Leakage current	100 μA or less at 24 VDC				0.8 mA or less	
Indicator light	Operating position Red LED illuminates. Optimum operating position Green LED illuminates.					
Standards	Conforming to CE standards					

- Lead wires — Oilproof flexible heavy-duty vinyl cable: $\phi 2.7 \times 3.2$ ellipse
D-M9BW(V) 0.15 mm² x 2 cores
D-M9NW(V), D-M9PW(V) 0.15 mm² x 3 cores

Note 1) Refer to page 27 for solid state switch common specifications.

Note 2) Refer to page 27 for lead wire lengths.

Weight

Unit: g

Auto switch model	D-M9NW(V)	D-M9PW(V)	D-M9BW(V)
Lead wire length (m)			
0.5	8	8	7
1	14	14	13
3	41	41	38
5	68	68	63

Dimensions

Unit: mm

D-M9□W

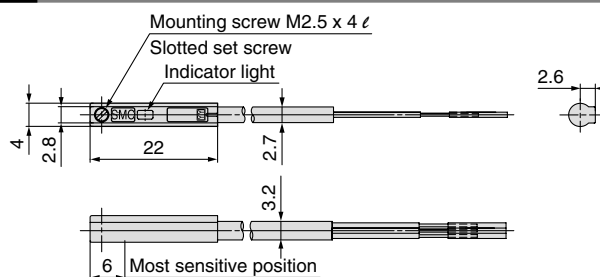

D-M9□WV

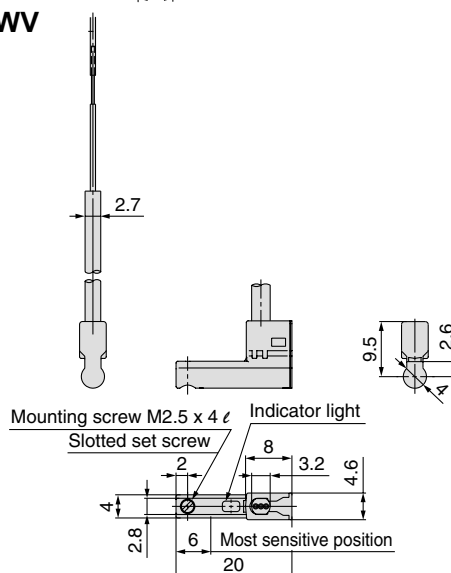

Water Resistant 2-Colour Indication Solid State Switch: Direct Mounting Style

D-M9NA(V)/D-M9PA(V)/D-M9BA(V)

Grommet

- Water (coolant) resistant type
- 2-wire load current is reduced (2.5 to 40 mA).
- UL certified (style 2844) lead cable is used.
- Using flexible cable as standard spec.
- The optimum operating position can be determined by the colour of the light. (Red → Green ← Red)



Auto Switch Internal Circuit

D-M9NA(V)

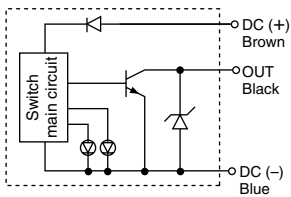

D-M9PA(V)

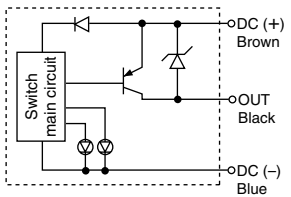

D-M9BA(V)

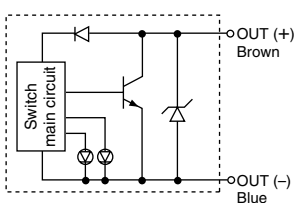

Indicator light / Display method

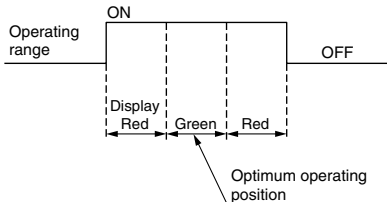

Auto Switch Specifications

PLC: Programmable Logic Controller

D-M9□A(V) (With indicator light)						
Auto switch model	D-M9NA	D-M9NAV	D-M9PA	D-M9PAV	D-M9BA	D-M9BAV
Electrical entry direction	In-line	Perpendicular	In-line	Perpendicular	In-line	Perpendicular
Wiring type	3-wire				2-wire	
Output type	NPN		PNP		—	
Applicable load	IC circuit, Relay, PLC				24 VDC relay, PLC	
Power supply voltage	5, 12, 24 VDC (4.5 to 28 V)				—	
Current consumption	10 mA or less				—	
Load voltage	28 VDC or less		—		24 VDC (10 to 28 VDC)	
Load current	40 mA or less				2.5 to 40 mA	
Internal voltage drop	0.8 V or less at 10 mA (2 V or less at 40 mA)				4 V or less	
Leakage current	100 μA or less at 24 VDC				0.8 mA or less	
Indicator light	Operating position Red LED illuminates. Optimum operating position Green LED illuminates.					
Standards	Conforming to CE standards					

- Lead wires — Oilproof flexible heavy-duty vinyl cable: $\phi 2.7 \times 3.2$ ellipse
D-M9BA(V) 0.15 mm² x 2 cores
D-M9NA(V), D-M9PA(V) 0.15 mm² x 3 cores

Note 1) Refer to page 27 for solid state switch common specifications.

Note 2) Refer to page 27 for lead wire lengths.

Weight

Unit: g

Auto switch model	D-M9NA(V)	D-M9PA(V)	D-M9BA(V)	
Lead wire length (m)	0.5	8	8	7
	1	14	14	13
	3	41	41	38
	5	68	68	63

Dimensions

Unit: mm

D-M9□A

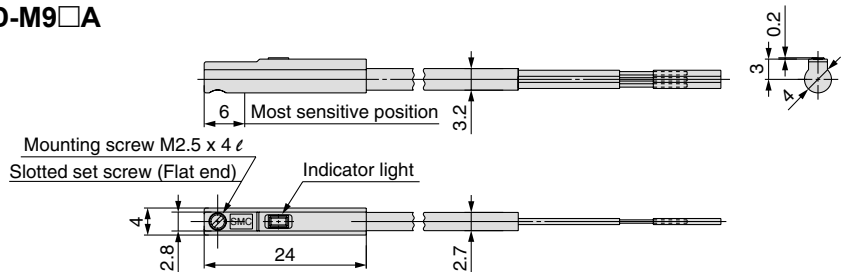

D-M9□AV

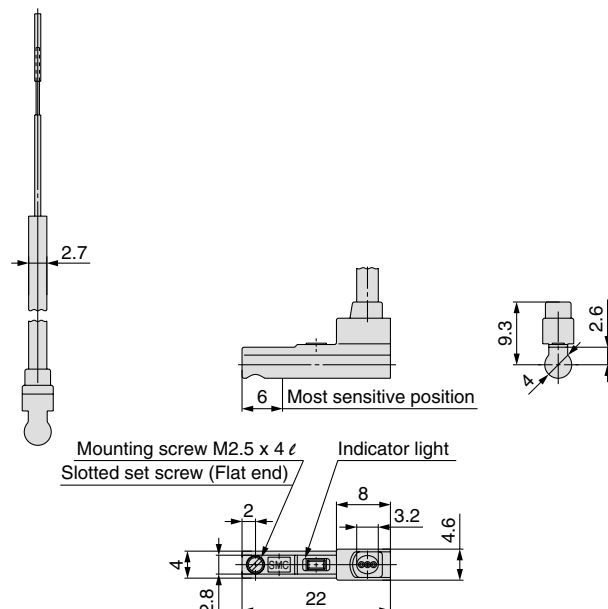

2-Colour Indication with Diagnostic Output Solid State Switch: Rail Mounting Style D-F79F



Grommet

- Since the output signal can be detected in an unsteady detecting area, the difference of detecting position can be confirmed by the side of PLC (Programmable Logic Controller).
- The optimum operating position can be determined by the colour of the light. (Red → Green ← Red)



Auto Switch Internal Circuit

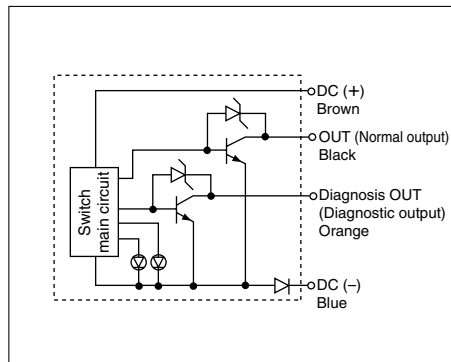

Auto Switch Specifications

PLC: Programmable Logic Controller

D-F79F (With indicator light)	
Auto switch model	D-F79F
Wiring type	4-wire
Output type	NPN
Diagnostic output type	Normal operation
Applicable load	IC circuit, Relay, PLC
Power supply voltage	5, 12, 24 VDC (4.5 to 28 VDC)
Current consumption	10 mA or less
Load voltage	28 VDC or less
Load current	50 mA or less at the total amount of normal output and diagnostic output
Internal voltage drop	1.5 V or less (0.8 V or less at 5 mA)
Leakage current	100 μ A or less at 24 VDC
Indicator light	Operating position Red LED illuminates. Optimum operating position Green LED illuminates.
Standards	Conforming to CE standards

- Lead wires — Oilproof heavy-duty vinyl cable: ϕ 3.4, 0.2 mm² x 4 cores (Brown, Black, Orange, Blue), 0.5 m
- Note 1) Refer to page 27 for solid state switch common specifications.
- Note 2) Refer to page 27 for lead wire lengths.

Weight

Unit: g

Auto switch model		D-F79F
Lead wire length (m)	0.5	13
	3	56
	5	90

Diagnostic Output Operation

The diagnostic signal is output within unsteady detecting area (where indicator light is Red), and the diagnostic output becomes OFF when the detecting position remains within the optimum operating position (where indicator is Green). When the detecting position is not adjusted, the diagnostic output becomes ON.

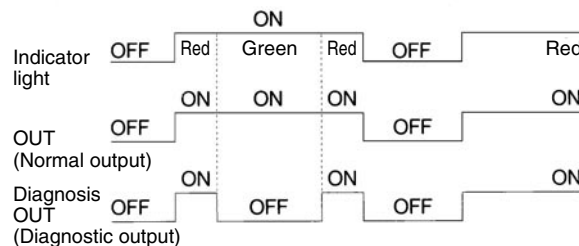

Dimensions

Unit: mm

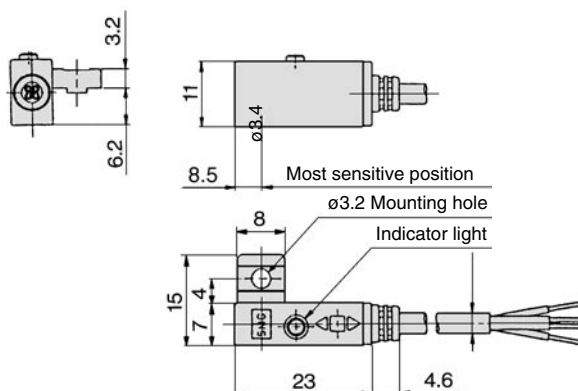

Magnetic Field Resistant 2-Colour Indication Solid State Switch: Rail Mounting Style

D-P4DWL/Z



Grommet

- It is possible to use in an environment which generates a magnetic field disturbance (AC magnetic field).
- The optimum operating position can be determined by the colour of the light. (Red → Green ← Red)



Caution

Precautions

For single-phase AC welding machines. Not applicable for DC inverter welding machines (including rectifying type) and or condenser type welding.

Auto Switch Internal Circuit

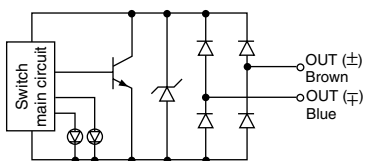

Indicator light / Display method

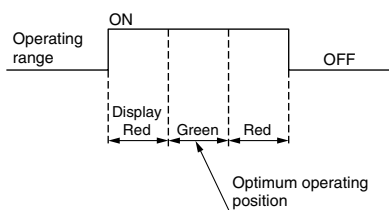

Auto Switch Specifications

PLC: Programmable Logic Controller

D-P4DW□ (With indicator light)		
Auto switch model	D-P4DWL	D-P4DWZ
Wiring type	2-wire (No polarity)	
Applicable load	24 VDC relay, PLC	
Load voltage	24 VDC (20 to 28 VDC)	
Load current	6 to 40 mA or less	
Internal voltage drop	5 V or less	
Leakage current	1 mA or less at 24 VDC	
Operating time	40 ms or less	
Indicator light	Operating position.....Red LED illuminates when turned ON. Optimum operating position.....Green LED illuminates when turned ON.	
Standards	Conforming to CE standards	

- Lead wire — Oilproof fire resistant heavy-duty vinyl cable, $\phi 6$, 0.5 mm², 2 cores, D-P4DWL: 3 m, D-P4DWZ: 5 m
 - Impact resistance — Switch part 1000 m/s²
 - Insulation resistance — 50 M Ω or more at 500 VDC Mega (between lead wire and case)
 - Withstand voltage — 1000 VAC for 1 minute (between lead wire and case)
 - Ambient temperature — -10 to 60°C
 - Enclosure — IEC60529 standard IP67, JIS 0920 waterproof construction
- Note 1) Refer to page 27 for solid state switch common specifications.
Note 2) Refer to page 27 for lead wire lengths.

Weight

Unit: g

Auto switch model	D-P4DW	
Lead wire length (m)	0.5	—
	3	150
	5	244

Magnetic Field Resistance

If the current of the AC welding machine is 16000 A or lower, the switch can be used, even if the distance between the welding conductor (gun cable) and the cylinder or switch is 0 mm. Please contact SMC when the AC welding current exceeds 16000 A.

Dimensions

Unit: mm

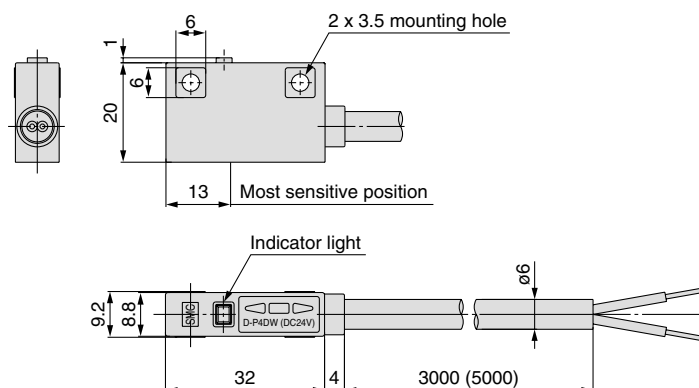

Series MK/MK2T Made to Order



1 Heat Resistant Cylinder (-10 to 150°C)

Symbol
XB6

Air cylinder with special seal material and grease, so that it could be used even at high temperatures up to 150°C from -10°C.

How to Order

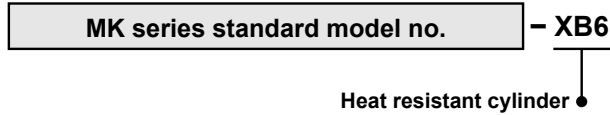

- Note 1) Operate without lubrication from a pneumatic system lubricator.
- Note 2) Please contact SMC for details on the maintenance intervals for this cylinder, which differs from those of the standard cylinder.
- Note 3) In principle, it is impossible to make built-in magnet type and/or with auto switch. Please contact SMC for availability with auto switch and/or heat resistant cylinder with heat resistant auto switch.
- Note 4) Piston speed is ranged from 50 to 200 mm/s.

Specifications

Applicable series	MK
Ambient temperature range	-10 to 150°C
Seal material	Fluoro rubber
Grease	Heat resistant grease
Specifications other than above and external dimensions	Same as standard product

Warning Precautions

Be aware that smoking cigarettes, etc. after your hands have come into contact with the grease used in this cylinder can create a gas that is hazardous to humans.

2 With Head End Pin Hole

Symbol
X1859

How to Order

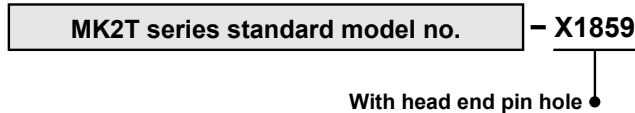

Specifications

Applicable series	MK2T
Bore size	ø32, ø40, ø50, ø63
Specifications other than above	Same as standard product

Dimensions

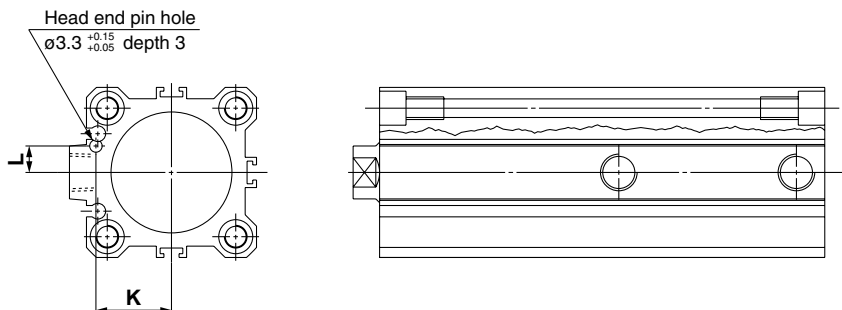

Bore size (mm)	K	L
32	20 ±0.15	7 ±0.15
40	24 ±0.15	7 ±0.15
50	30 ±0.15	8 ±0.15
63	35 ±0.15	9 ±0.15



* Dimensions other than above are the same as basic type.



Series MK/MK2/MK2T Safety Instructions

These safety instructions are intended to prevent a hazardous situation and/or equipment damage. These instructions indicate the level of potential hazard by labels of "Caution", "Warning" or "Danger". To ensure safety, be sure to observe ISO 4414 ^{Note 1)}, JIS B 8370 ^{Note 2)} and other safety practices.

■ Explanation of the Labels

Labels	Explanation of the labels
 Danger	In extreme conditions, there is a possible result of serious injury or loss of life.
 Warning	Operator error could result in serious injury or loss of life.
 Caution	Operator error could result in injury ^{Note 3)} or equipment damage. ^{Note 4)}

Note 1) ISO 4414: Pneumatic fluid power – General rules relating to systems

Note 2) JIS B 8370: General Rules for Pneumatic Equipment

Note 3) Injury indicates light wounds, burns and electrical shocks that do not require hospitalization or hospital visits for long-term medical treatment.

Note 4) Equipment damage refers to extensive damage to the equipment and surrounding devices.

■ Selection/Handling/Applications

1. The compatibility of the pneumatic equipment is the responsibility of the person who designs the pneumatic system or decides its specifications.

Since the products specified here are used in various operating conditions, their compatibility for the specific pneumatic system must be based on specifications or post analysis and/or tests to meet the specific requirements. The expected performance and safety assurance are the responsibility of the person who has determined the compatibility of the system. This person should continuously review the suitability of all items specified, referring to the latest catalogue information with a view to giving due consideration to any possibility of equipment failure when configuring a system.

2. Only trained personnel should operate pneumatically operated machinery and equipment.

Compressed air can be dangerous if handled incorrectly. Assembly, handling or repair of pneumatic systems should be performed by trained and experienced operators. (Understanding JIS B 8370 General Rules for Pneumatic Equipment, and other safety rules are included.)

3. Do not service machinery/equipment or attempt to remove components until safety is confirmed.

1. Inspection and maintenance of machinery/equipment should only be performed once measures to prevent falling or runaway of the driven objects have been confirmed.
2. When equipment is removed, confirm that safety process as mentioned above. Turn off the supply pressure for this equipment and exhaust all residual compressed air in the system, and release all the energy (liquid pressure, spring, condenser, gravity).
3. Before machinery/equipment is restarted, take measures to prevent quick extension of a cylinder piston rod, etc.

4. If the equipment will be used in the following conditions or environment, please contact SMC first and be sure to take all necessary safety precautions.

1. Conditions and environments beyond the given specifications, or if product is used outdoors.
2. Installation on equipment in conjunction with atomic energy, railway, air navigation, vehicles, medical equipment, food and beverages, recreation equipment, emergency stop circuits, clutch and brake circuits in press applications, or safety equipment.
3. An application which has the possibility of having negative effects on people and/or property, requiring special safety analysis.
4. If the products are used in an interlock circuit, prepare a double interlock style circuit with a mechanical protection function for the prevention of a breakdown. And, examine the devices periodically if they function normally or not.

■ Exemption from Liability

1. SMC, its officers and employees shall be exempted from liability for any loss or damage arising out of earthquakes or fire, action by a third person, accidents, customer error with or without intention, product misuse, and any other damages caused by abnormal operating conditions.

2. SMC, its officers and employees shall be exempted from liability for any direct or indirect loss or damage, including consequential loss or damage, loss of profits, or loss of chance, claims, demands, proceedings, costs, expenses, awards, judgments and any other liability whatsoever including legal costs and expenses, which may be suffered or incurred, whether in tort (including negligence), contract, breach of statutory duty, equity or otherwise.

3. SMC is exempted from liability for any damages caused by operations not contained in the catalogues and/or instruction manuals, and operations outside of the specification range.

4. SMC is exempted from liability for any loss or damage whatsoever caused by malfunctions of its products when combined with other devices or software.



Series MK/MK2/MK2T

Auto Switches

Precautions 1

Be sure to read this before handling.

Design and Selection

Warning

1. Confirm the specifications.

Read the specifications carefully and use this product appropriately.

The product may be damaged or malfunction if it is used outside the range of specifications of current load, voltage, temperature or impact. We do not guarantee any damage in any case the product is used outside of the specification range.

2. Keep wiring as short as possible.

<Reed switch>

As the length of the wiring to a load gets longer, the rush current at switching ON becomes greater, and this may shorten the product's life. (The switch will stay ON all the time.)

Use a contact protection box when the wire length is 5 m or longer.

<Solid state switch>

Although wire length should not affect switch function, use a wire 100 m or shorter.

If the wiring is longer it will likely increase noise although the length is less than 100 m.

When the wire length is long, we recommend attaching the ferrite core to the both ends of the cable to prevent excess noise. Since the solid state switch is a semiconductor switch which has no contacts, no contact protection box is needed.

3. Do not use a load that generates surge voltage. If a surge voltage is generated, the discharge occurs at the contact, possibly resulting in the shortening of product life.

<Reed switch>

If driving a load such as a relay that generates a surge voltage, use a switch with a built-in contact protection circuit or use a contact protection box.

<Solid state switch>

Although a zener diode for surge protection is connected at the output side of a solid state switch, damage may still occur if the surge is applied repeatedly. When a load, such as a relay or solenoid, which generates surge is directly driven, use a type of switch with a built-in surge absorbing element.

4. Caution when using in an interlock circuit

When an auto switch is used for an interlock signal requiring high reliability, devise a double interlock system to avoid trouble by providing a mechanical protection function, or by also using another switch (sensor) together with the auto switch. Also perform periodic maintenance and confirm proper operation.

5. Do not make any modifications (including exchanging the printed circuit boards) to the product.

It may cause human injuries and accidents.

Caution

1. Use caution when multiple actuators are used and close to each other.

When two or more auto switch actuators are lined up in close proximity to each other, magnetic field interference may cause the switches to malfunction. Maintain a minimum cylinder separation of 40 mm. (When the allowable interval is specified for each cylinder series, use the indicated value.)

Use of a magnetic screen plate (MU-S025) or magnetic screen tape can reduce the interference of magnetic force.

2. Take note of the internal voltage drop of the auto switch.

<Reed switch>

1) Auto switches with an indicator light (except Model D-A96, A96V, A76H)

- If auto switches are connected in series as shown below, take note that there will be a large voltage drop because of internal resistance in the light emitting diodes. (Refer to the internal voltage drop in the auto switch specifications.) [The voltage drop will be "n" times larger when "n" auto switches are connected.]

Even though an auto switch operates normally, the load may not operate.

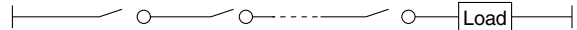

- In the same way, when operating under a specified voltage, although an auto switch may operate normally, the load may not operate. Therefore, the formula below should be satisfied after confirming the minimum operating voltage of the load.

$$\text{Supply voltage} - \text{Internal voltage drop of switch} > \text{Minimum operating voltage of load}$$

2) If the internal resistance of a light emitting diode causes a problem, select a switch without an indicator light (Model D-A90, A90V, A80(H)(C)).

<Solid state switch>

3) Generally, the internal voltage drop will be greater with a 2-wire solid state switch than with a reed switch. Take the same precautions as in 1).

Also, note that a 12 VDC relay is not applicable.

3. Pay attention to leakage current.

<Solid state switch>

With a 2-wire solid state switch, current (leakage current) flows to the load to operate the internal circuit even when in the OFF state.

$$\text{Operating current of load (OFF condition)} > \text{Leakage current}$$

If the criteria given in the above formula are not met, it will not reset correctly (stays ON). Use a 3-wire switch if this specification will not be satisfied.

Moreover, leakage current flow to the load will be "n" times larger when "n" auto switches are connected in parallel.

4. Ensure sufficient clearance for maintenance activities.

When designing an application, be sure to allow sufficient clearance for maintenance and inspections.



Series MK/MK2/MK2T

Auto Switches

Precautions 2

Be sure to read this before handling.

Mounting and Adjustment

Warning

1. Operating manual

Install the products and operate them only after reading the operating manual carefully and understanding its contents. Also, keep the manual where it can be referred to as necessary.

2. Do not drop or bump.

Do not drop, bump or apply excessive impacts (300 m/s² or more for reed switches and 1000 m/s² or more for solid state switches) while handling. Although the body of the auto switch may not be damaged, the inside of the auto switch could be damaged and cause a malfunction.

3. Mount auto switches using the proper fastening torque.

When a switch is tightened beyond the range of fastening torque, the mounting screws, auto switches, auto switch mounting bracket, etc. may be damaged. On the other hand, tightening below the range of fastening torque may allow the switch to slip out of position. (Refer to the auto switch mounting for each series regarding auto switch mounting, moving, and fastening torque, etc.)

4. Mount an auto switch at the center of the operating range.

Adjust the mounting position of an auto switch so that the piston stops at the center of the operating range (the range in which a switch is ON). (The mounting position shown in a catalog indicates the optimum position at stroke end.) If mounted at the end of the operating range (around the borderline of ON and OFF), operation will be unstable or the service life will be shortened.

<D-M9□(V)>

When the auto switch is used to replace old series auto switch, it may not activate depending on operating condition because of its shorter operating range.

Such as

- **Application where the stop position of actuator may vary and exceed the operating range of the auto switch, for example, pushing, pressing, clamping operation, etc.**
- **Application where the auto switch is used for detecting an intermediate stop position of the actuator. (In this case the detecting time will be reduced.)**

In these applications, set the auto switch to the center of the required detecting range.

Caution

1. Do not carry an actuator by the auto switch lead wires.

Never carry a cylinder (actuator) by its lead wires. This may not only cause broken lead wires, but it may cause internal elements of the auto switch to be damaged by the stress.

2. Fix the auto switch with appropriate screw installed on the auto switch body. If using other screws, auto switch may be damaged.

Wiring

Warning

1. Confirm proper insulation of wiring.

Be certain that there is no faulty wiring insulation (contact with other circuits, ground fault, improper insulation between terminals, etc.). Damage may occur due to excess current flow into a switch.

2. Do not wire with power lines or high-voltage lines.

Wire separately from power lines or high-voltage lines, avoiding parallel wiring or wiring in the same conduit with these lines. Control circuits, including auto switches, may malfunction due to noise from these other lines.

Caution

1. Avoid repeatedly bending or stretching lead wires.

Repeated bending or tensile force applied to the lead wire may cause the sheath to fall off or disconnection of the wire.

If bending or tensile force are not avoidable, fix the lead wire close to the switch and allow a bend radius of R40 to 80 mm or larger. Consult SMC for details. Stress and tensile force applied to the connection between the cable and switch increases the possibility of disconnection.

Fix the cable in the middle so that it is not movable in the area where it connects with the switch.

2. Be sure to connect the load before power is applied.

<2-wire type>

If the power is turned ON when an auto switch is not connected to a load, the switch will be instantly damaged because of excess current.

It is the same as when the 2-wire brown cord (+, output) is directly connected to the (+) power supply terminal.

3. Do not allow short circuit of loads.

<Reed switch>

If the power is turned ON with a load in a short circuited condition, the switch will be instantly damaged because of excess current flow into the switch.

<Solid state switch>

Model D-M9□(V) and all models of PNP output type switches do not have built-in short circuit prevention circuits. If loads are short circuited, the switches will be instantly damaged, as in the case of reed switches.

Take special care to avoid reverse wiring with the power supply line (brown) and the output line (black) on 3-wire type switches.



Series MK/MK2/MK2T

Auto Switches

Precautions 3

Be sure to read this before handling.

Wiring

⚠ Caution

4. Avoid incorrect wiring.

<Reed switch>

A 24 VDC switch with indicator light has polarity. The brown lead wire is (+) and the blue lead wire (-).

1) If connections are reversed, a switch will operate, however, the light emitting diode will not light up. (For D-A79W, the output signal will be sent, but the LED will not operate.)

Also note that a current greater than that specified will damage a light emitting diode and it will no longer operate.

Applicable models:

D-A93, A73(H)(C), A79W

<Solid state switch>

1) If connections are reversed on a 2-wire type switch, the auto switch will not be damaged if protected by a protection circuit, but the switch will always stay in an ON state.

However, it is still necessary to avoid reversed connections, since the auto switch could be damaged by a load short circuit in this condition.

2) If connections are reversed (power supply line + and power supply line -) on a 3-wire type switch, the switch will be protected by a protection circuit. However, if the power supply line (+) is connected to the blue wire and the power supply line (-) is connected to the black wire, the auto switch will be damaged.

<D-M9□>

The D-M9□ does not have built-in short circuit protection circuit. Be aware that if the power supply connection is reversed (e.g. (+) power supply wire and (-) power supply wire connection is reversed), the auto switch will be damaged.

5. When the cable sheath is stripped, confirm the stripping direction. The insulator may be split or damaged depending on the direction. (D-M9□, M9□W, M9□A(V)L only)

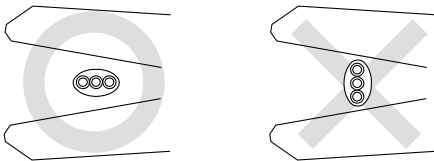

Recommended Tool

Model name	Model no.
Wire stripper	D-M9N-SWY

* Stripper for a round cable (ø2.0) can be used for a 2-wire type cable.

Operating Environment

⚠ Warning

1. Never use in an atmosphere of explosive gases.

The construction of auto switches is not intended to prevent explosion. Never use in an atmosphere with an explosive gas since this may cause a serious explosion.

2. Do not use in an area where a magnetic field is generated.

Auto switches will malfunction or magnets inside actuators will become demagnetised.

3. Do not use in an environment where the auto switch will be continually exposed to water.

Although switches, satisfy IEC standard IP67 construction (JIS C 0920: waterproof construction), do not use switches in applications where continually exposed to water splash or spray. Poor insulation or swelling of the potting resin inside auto switches may cause malfunction.

4. Do not use in an environment with oil or chemicals.

Consult SMC if auto switches will be used in an environment with coolant, cleaning solvent, various oils or chemicals. If auto switches are used under these conditions for even a short time, they may be adversely affected by improper insulation, malfunction due to swelling of the potting resin, or hardening of the lead wires.

5. Do not use in an environment with temperature cycles.

Consult SMC if switches are used where there are temperature cycles other than normal temperature changes, as they may be adversely affected internally.

6. Do not use in an environment where there is excessive impact shock.

<Reed switch>

When excessive impact (300 m/s² or more) is applied to a reed switch during operation, the contact point will malfunction and generate or cut off a signal momentarily (1 ms or less). Consult SMC regarding the need to use a solid state switch depending upon the environment.

7. Do not use in an area where surges are generated.

<Solid state switch>

When there are units (solenoid type lifter, high-frequency induction furnace, motor, etc.) which generate large surges in the area around actuators with solid state auto switches, this may cause deterioration or damage to the auto switches. Avoid sources of surge generation and crossed lines.



Series *MK/MK2/MK2T* Auto Switches Precautions 4

Be sure to read this before handling.

Operating Environment

Caution

1. Avoid accumulation of iron debris or close contact with magnetic substances.

When a large amount of ferrous debris such as machining chips or spatter is accumulated, or a magnetic substance (something attracted by a magnet) is brought into close proximity with an auto switch actuator, it may cause the auto switch (actuator) to malfunction due to a loss of the magnetic force inside the actuator.

2. Consult SMC concerning water resistance, elasticity of lead wires, usage at welding sites, etc.

3. Do not use in direct sunlight.

4. Do not mount the product in locations where it is exposed to radiant heat.

Maintenance

Warning

1. Perform the following maintenance periodically in order to prevent possible danger due to unexpected auto switch malfunction.

- 1) Securely tighten auto switch mounting screws.
If screws become loose or the mounting position is dislocated, retighten them after readjusting the mounting position.
- 2) Confirm that there is no damage to lead wires.
To prevent faulty insulation, replace auto switches or repair lead wires, etc., if damage is discovered.
- 3) Confirm the lighting of the green light on the 2-colour indicator type auto switch.
Confirm that the green LED is on when stopped at the established position. If the red LED is on, the mounting position is not appropriate. Readjust the mounting position until the green LED lights up.

2. Maintenance procedures are outlined in the operating manual.

Not following proper procedures could cause the product to malfunction and could lead to damage to the equipment or machine.

3. Removal of equipment, and supply/exhaust of compressed air

Before any machinery or equipment is removed, first ensure that the appropriate measures are in place to prevent the fall or erratic movement of driven objects and equipment, then cut off the electric power and reduce the pressure in the system to zero. Only then should you proceed with the removal of any machinery and equipment.

When machinery is restarted, proceed with caution after confirming that appropriate measures are in place to prevent actuators from moving suddenly.



Series MK/MK2/MK2T Specific Product Precautions 1

Be sure to read this before handling.

Refer to back page 1 for Safety Instructions and "Precautions for Handling Pneumatic Devices" (M-03-E3A) for Common Precautions.

Operating Environment

⚠ Warning

1. Do not use the cylinder under the following environments:

- 1) Areas in which fluids such as cutting oil splash on the piston rod.
- 2) Areas in which foreign matter such as particles, cutting chips, dust, or spatter is present.
- 3) Areas in which the ambient temperature exceeds the operating range.
- 4) Areas exposed to direct sunlight.
- 5) Environments that pose the risk of corrosion.

Clamp Arm Removal and Reinstallation

⚠ Warning

1. To remove and reinstall the arm on the piston rod, instead of securing the cylinder body, use a wrench to secure the arm to loosen or to tighten the bolt (Fig. (1)).

An excessive amount of rotational force will be applied to the piston rod if the bolt is tightened by securing the cylinder body, which could damage the internal parts.

To fabricate an arm, make sure to machine a detect portion that corresponds to the parallel section at the rod end.

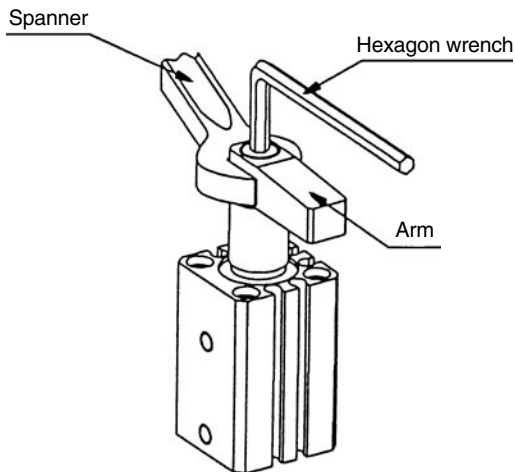
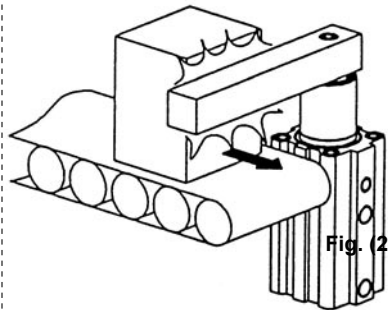

Fig. (1)

Mounting Arms for Width Across Flats (MK Only)

⚠ Warning

1. When installing the arm for the parallel section at the rod end, the strength of the piston rod might be insufficient depending on the direction in which the arm is installed. Therefore, make sure to install the arm in the direction indicated in Figure A. (Fig. (2))



Speed Adjustment

⚠ Warning

1. Make sure to connect a speed controller to the cylinder and adjust it so that the cylinder speed will be within a range of 50 to 200 mm/s.

If a clamp arm other than the available option is used, make sure to select an appropriate arm after calculating the inertial moment of the arm.

To operate a speed controller, make sure that the valve is fully closed, and gradually open the valve to adjust the speed.



Series MK/MK2/MK2T

Specific Product Precautions 2

Be sure to read this before handling.

Refer to back page 1 for Safety Instructions and "Precautions for Handling Pneumatic Devices" (M-03-E3A) for Common Precautions.

Operating Environment

Warning

1. A cylinder could malfunction or the non-rotating accuracy could be affected if a rotational force is applied to the piston rod. Therefore, observe the particulars given below before operating the cylinder.

- 1) Make sure to mount the cylinder vertically (Fig. (3)). (MK, MK2 only)
- 2) Do not perform any work (such as clamping or acting as a stopper, etc.) in the rotary direction (Fig. (4)).
- 3) To clamp, make sure to do so within the clamp stroke (straight-line stroke) range (Fig. (5)).
- 4) Make sure that the clamping surface of the workpiece is perpendicular to the cylinder's axial line (Fig. (6)).
- 5) Do not operate the cylinder in such a way that an external force causes the workpiece to move while being clamped (Fig. (7)).
- 6) Furthermore, do not operate the cylinder in an application in which a rotational force will be applied to the piston rod.

1) Do not operate the cylinder horizontally.

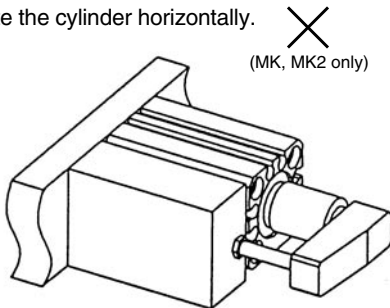

Fig. (3)

2) Do not perform any work in the rotary direction.

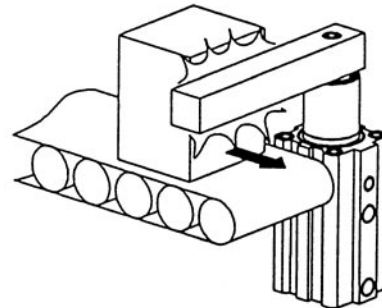

Fig. (4)

3) Do not clamp during the rotary stroke.

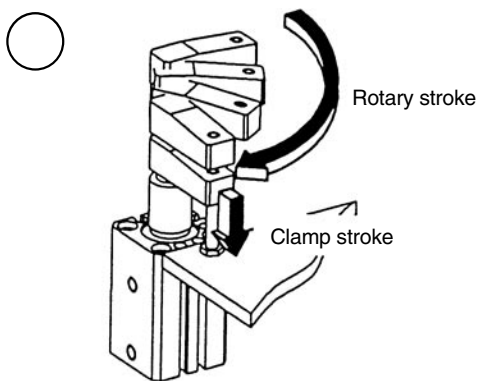
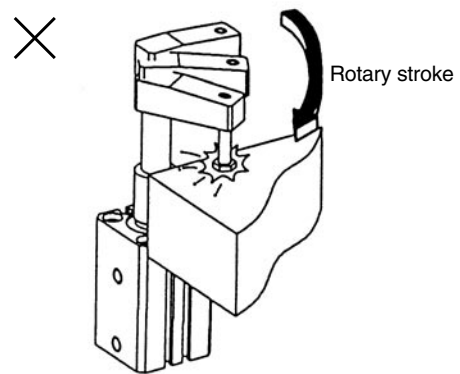

Fig. (5)



4) Do not clamp on a slanted surface.

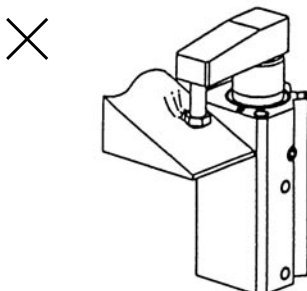

Fig. (6)

5) Make sure that the workpiece does not move during clamping.

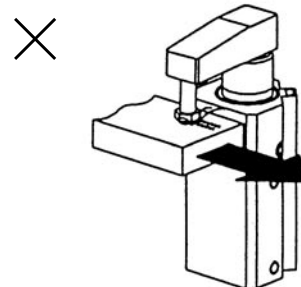

Fig. (7)



Series MK/MK2/MK2T Specific Product Precautions 3

Be sure to read this before handling.
Refer to back page 2 through 5 for Auto Switches precautions.

Mounting

- When a magnetic substrate surrounds the cylinder as shown in the figure below (including when the magnetic substrate is only on one side of the cylinder), the movement of the auto switch may become unstable, so please check it separately.

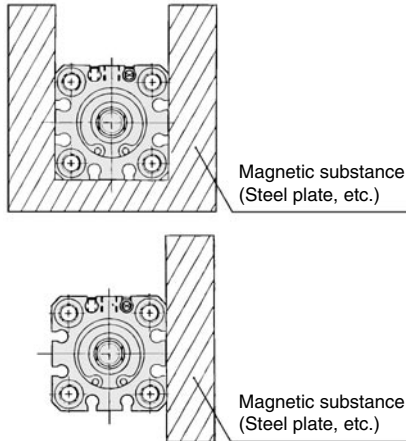

With Magnetic Field Resistant Auto Switch D-P4DWL

- If welding cables or welding gun electrodes are in the vicinity of the cylinder, the magnets in the cylinder could be affected by the external magnetic fields. (Contact SMC if the welding amperage exceeds 16000 A.) If the source of strong magnetism comes in contact with the cylinder or an auto switch, make sure to install the cylinder away from the source of the magnetism. If the cylinder is to be used in an environment in which spatter will come in direct contact with the lead wires, cover the lead wires with a protective tube. For the protective tube, use a tube I.D. $\phi 7$ or more, which excels in heat resistance and flexibility. Contact SMC if an inverter welder or a DC welder will be used.

Calculation of Moment of Inertia

I: Moment of inertia (kg·m²) m: Load mass (kg)

1. Thin shaft

Position of rotational axis:
Vertical to the bar and through the end

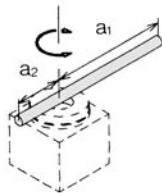

$$I = m_1 \cdot \frac{a_1^2}{3} + m_2 \cdot \frac{a_2^2}{3}$$

4. Thin rectangular plate (Rectangular parallelepiped)

Position of rotational axis:
Vertical to the plate and through the end

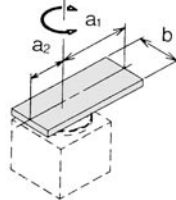

$$I = m_1 \cdot \frac{4a_1^2 + b^2}{12} + m_2 \cdot \frac{4a_2^2 + b^2}{12}$$

2. Thin shaft

Position of rotational axis:
Perpendicular to the shaft through the center of gravity

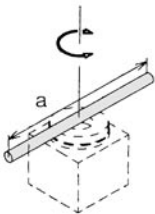

$$I = m \cdot \frac{a^2}{12}$$

5. Thin rectangular plate (Rectangular parallelepiped)

Position of rotational axis:
Through the center of gravity and vertical to the plate
(Same as also thick rectangular plate)

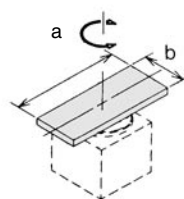

$$I = m \cdot \frac{a^2 + b^2}{12}$$

3. Thin rectangular plate (Rectangular parallelepiped)

Position of rotational axis:
Parallel to side b through the center of gravity

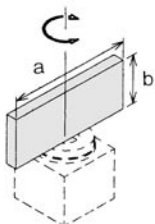

$$I = m \cdot \frac{a^2}{12}$$

6. Load at the end of lever arm

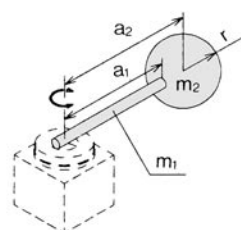

$$I = m_1 \cdot \frac{a_1^2}{3} + m_2 \cdot a_2^2 + K$$

$$k = m_2 \cdot \frac{2r^2}{5}$$

EUROPEAN SUBSIDIARIES:

Austria

SMC Pneumatik GmbH (Austria).
Girakstrasse 8, A-2100 Korneuburg
Phone: +43 2262-62280, Fax: +43 2262-62285
E-mail: office@smc.at
http://www.smc.at

France

SMC Pneumatique, S.A.
1, Boulevard de Strasbourg, Parc Gustave Eiffel
Bussy Saint Georges F-77607 Marne La Vallée Cedex 3
Phone: +33 (0)1-6476 1000, Fax: +33 (0)1-6476 1010
E-mail: contact@smc-france.fr
http://www.smc-france.fr

Netherlands

SMC Pneumatics BV
De Ruyterkade 120, NL-1011 AB Amsterdam
Phone: +31 (0)20-5318888, Fax: +31 (0)20-5318880
E-mail: info@smcpneumatics.nl
http://www.smcneumatics.nl

Spain

SMC España, S.A.
Zuazobidea 14, 01015 Vitoria
Phone: +34 945-184 100, Fax: +34 945-184 124
E-mail: post@smc.smces.es
http://www.smc.eu

Belgium

SMC Pneumatics N.V./S.A.
Nijverheidsstraat 20, B-2160 Wommelgem
Phone: +32 (0)3-355-1464, Fax: +32 (0)3-355-1466
E-mail: info@smcpneumatics.be
http://www.smcneumatics.be

Germany

SMC Pneumatik GmbH
Boschring 13-15, D-63329 Egelsbach
Phone: +49 (0)6103-4020, Fax: +49 (0)6103-402139
E-mail: info@smc-pneumatik.de
http://www.smc-pneumatik.de

Norway

SMC Pneumatics Norway A/S
Vollsveien 13 C, Granfos Næringspark N-1366 Lysaker
Tel: +47 67 12 90 20, Fax: +47 67 12 90 21
E-mail: post@smc-norge.no
http://www.smc-norge.no

Sweden

SMC Pneumatics Sweden AB
Ekhagsvägen 29-31, S-141 71 Huddinge
Phone: +46 (0)8-603 12 00, Fax: +46 (0)8-603 12 90
E-mail: post@smcpneumatics.se
http://www.smc.nu

Bulgaria

SMC Industrial Automation Bulgaria EOOD
Business Park Sofia, Building 8 - 6th floor, BG-1715 Sofia
Phone: +359 2 9744492, Fax: +359 2 9744519
E-mail: office@smc.bg
http://www.smc.bg

Greece

SMC Hellas EPE
Anagenniseos 7-9 - P.C. 14342, N. Philadelphia, Athens
Phone: +30-210-2717265, Fax: +30-210-2717766
E-mail: sales@smchellas.gr
http://www.smchellas.gr

Poland

SMC Industrial Automation Polska Sp.z.o.o.
ul. Poloneza 89, PL-02-826 Warszawa
Phone: +48 22 211 9600, Fax: +48 22 211 9617
E-mail: office@smc.pl
http://www.smc.pl

Switzerland

SMC Pneumatik AG
Dorfstrasse 7, CH-8484 Weisslingen
Phone: +41 (0)52-396-3131, Fax: +41 (0)52-396-3191
E-mail: info@smc.ch
http://www.smc.ch

Croatia

SMC Industrijska automatika d.o.o.
Crnomerec 12, HR-10000 ZAGREB
Phone: +385 1 377 66 74, Fax: +385 1 377 66 74
E-mail: office@smc.hr
http://www.smc.hr

Hungary

SMC Hungary Ipari Automatizálási Kft.
Torbágy út 19, H-2045 Törökbálint
Phone: +36 23 511 390, Fax: +36 23 511 391
E-mail: office@smc.hu
http://www.smc.hu

Portugal

SMC Sucursal Portugal, S.A.
Rua de Eng^o Ferreira Dias 452, 4100-246 Porto
Phone: +351 226 166 570, Fax: +351 226 166 589
E-mail: postpt@smc.smces.es
http://www.smc.eu

Turkey

Entek Pnömatik San. ve Tic. A*.
Perpa Ticaret Merkezi B Blok Kat:11 No: 1625, TR-34386, Okmeydanı, Istanbul
Phone: +90 (0)212-444-0762, Fax: +90 (0)212-221-1519
E-mail: smc@entek.com.tr
http://www.entek.com.tr

Czech Republic

SMC Industrial Automation CZ s.r.o.
Hudcova 78a, CZ-61200 Brno
Phone: +420 5 414 24611, Fax: +420 5 412 18034
E-mail: office@smc.cz
http://www.smc.cz

Ireland

SMC Pneumatics (Ireland) Ltd.
2002 Citywest Business Campus, Naas Road, Saggart, Co. Dublin
Phone: +353 (0)1-403 9000, Fax: +353 (0)1-464-0500
E-mail: sales@smcpneumatics.ie
http://www.smcneumatics.ie

Romania

SMC Romania srl
Str Frunzei 29, Sector 2, Bucharest
Phone: +40 213205111, Fax: +40 213261489
E-mail: smcromania@smcromania.ro
http://www.smcromania.ro

UK

SMC Pneumatics (UK) Ltd
Vincent Avenue, Crownhill, Milton Keynes, MK8 0AN
Phone: +44 (0)800 1382930 Fax: +44 (0)1908-555064
E-mail: sales@smcpneumatics.co.uk
http://www.smcneumatics.co.uk

Denmark

SMC Pneumatik A/S
Egeskovvej 1, 8700 Horsens
Phone: +45 70252900, Fax: +45 70252901
E-mail: smc@smcdk.com
http://www.smcdk.com

Italy

SMC Italia S.p.A
Via Garibaldi 62, I-20061 Carugate, (Milano)
Phone: +39 (0)2-92711, Fax: +39 (0)2-9271365
E-mail: mailbox@smcitalia.it
http://www.smcitalia.it

Russia

SMC Pneumatik LLC.
4B Sverdlovskaja nab, St. Petersburg 195009
Phone: +7 812 718 5445, Fax: +7 812 718 5449
E-mail: info@smc-pneumatik.ru
http://www.smc-pneumatik.ru

Estonia

SMC Pneumatics Estonia OÜ
Laki 12, 106 21 Tallinn
Phone: +372 6510370, Fax: +372 65110371
E-mail: smc@smcpneumatics.ee
http://www.smcneumatics.ee

Latvia

SMC Pneumatics Latvia SIA
Smerla 1-705, Riga LV-1006
Phone: +371 781-77-00, Fax: +371 781-77-01
E-mail: info@smclv.lv
http://www.smclv.lv

Slovakia

SMC Priemyselna Automatizacia, s.r.o.
Fatranska 1223, 01301 Teplicka Nad Vahom
Phone: +421 41 3213212 - 6 Fax: +421 41 3213210
E-mail: office@smc.sk
http://www.smc.sk

Finland

SMC Pneumatics Finland Oy
PL72, Tiistinniityntie 4, SF-02231 ESPOO
Phone: +358 207 513513, Fax: +358 207 513595
E-mail: smcfin@smc.fi
http://www.smc.fi

Lithuania

SMC Pneumatics Lietuva, UAB
Oslo g.1, LT-04123 Vilnius
Phone: +370 5 264 81 26, Fax: +370 5 264 81 26

Slovenia

SMC industrijska Avtomatika d.o.o.
Mirska cesta 7, SI-8210 Trebnje
Phone: +386 7 3885412 Fax: +386 7 3885435
E-mail: office@smc.si
http://www.smc.si

OTHER SUBSIDIARIES WORLDWIDE:

ARGENTINA, AUSTRALIA, BOLIVIA, BRASIL, CANADA, CHILE,
CHINA, HONG KONG, INDIA, INDONESIA, MALAYSIA, MEXICO,
NEW ZEALAND, PHILIPPINES, SINGAPORE, SOUTH KOREA,
TAIWAN, THAILAND, USA, VENEZUELA

<http://www.smc.eu>
<http://www.smcworld.com>