

# D. P. Lube (Unit)

# Series ALD(U)600/900

- Centralized control of multi-point lubrication
- Low oil consumption volume
- Simplified oil feeding volume setting in which only the pressure differential is adjusted.
- Oil can be replenished by merely opening and closing the oil filler plug without stopping the air line.
- The condition of the generation of micromist can be checked from the oil filler port.



ALD600



ALDU600 (with panel)

## Float Switch Specifications

Voltage	200 VAC, 200 VDC
Max. cut off capacity	12 VAC, 10 W DC
Max. cut off current	0.6 A AC, 0.5 A DC
Contact point construction	1a, 1b
Level indication	Bottom limit indication

## Standard Specifications

Model name	D.P. Lube		D.P. Lube Unit <sup>(1)</sup>	
	ALD600	ALD900	ALDU600	ALDU900
Port size <sup>(2)</sup>	3/4 1	1 1/4 1 1/2 2	3/4 1	1 1/4 1 1/2 2
Fluid	Air			
Proof pressure	1.5 MPa			
Operating pressure range	0.1 to 1.0 MPa		0.15 to 1.0 MPa	
Operating pressure differential range	0.03 to 0.1 MPa			
Recommended press. differential	0.05 MPa			
Press. differential setting min. flow <sup>(3)</sup>	102 ℓ/min (ANR)			
Bowl capacity between levels (cm <sup>3</sup> )	2000	5000	2000	5000
Recommended lubricant	Turbine oil Class 1 (With no additives), ISO VG32			
Ambient and fluid temperature	5 to 60°C			
Bowl material	Epoxy resin with glass fiber, Polycarbonate			
Weight (kg)	8.9	21.3	11.1 (18.6) <sup>(4)</sup>	31.6 (48.1) <sup>(4)</sup>



Note1) D.P. Lube unit has an attached filter at primary side of D.P. Lube.

Note2) Port of D.P. Lube unit is union.

Note3) Condition: Inlet pressure = 0.5 MPa, Pressure differential = 0.05 MPa

Note4) ( ) is weight with panel.

## Accessory (Option) Part No.

Description	Model	Part no.			
		ALD600	ALD900	ALDU600	ALDU900
Bracket		126130P	126044P	126130P	126044P 113449 <sup>(1)</sup> 113543 <sup>(2)</sup>
Panel		—	—	12661P	12651-1P
Float switch	S1	IS430-1	IS420-1	IS430-1	IS420-1
	S2	IS430-2	IS420-2	IS430-2	IS420-2



Note1) Bracket for filter mounting: For Rc 1 1/4, 1 1/2 } Thread machining on filter body is needed.

Note2) Bracket for filter mounting: For Rc 2

## How to Order

ALD	9	00	20	B	S1
<b>Style</b>					<b>Float switch</b>
ALD					Nil
ALDU					S1
<b>Body size (Standard)</b>					1b (without oil ON)
6	1B				S2
9	2B				1a (without oil OFF)
<b>Thread type</b>					<b>Accessory</b>
Nil					Symbol
N					Description
<b>Port size</b>					Nil
06	3/4				B
10	1				P
12	1 1/4				—
14	1 1/2				B
20	2				Bracket
					P
					Panel

F.R.L.

AV

AU

AF

AR

IR

VEX

AMR

ITV

IC

VBA

VE□

VY1

G

PPA

AL

# Series ALD600/900

## Piping Example

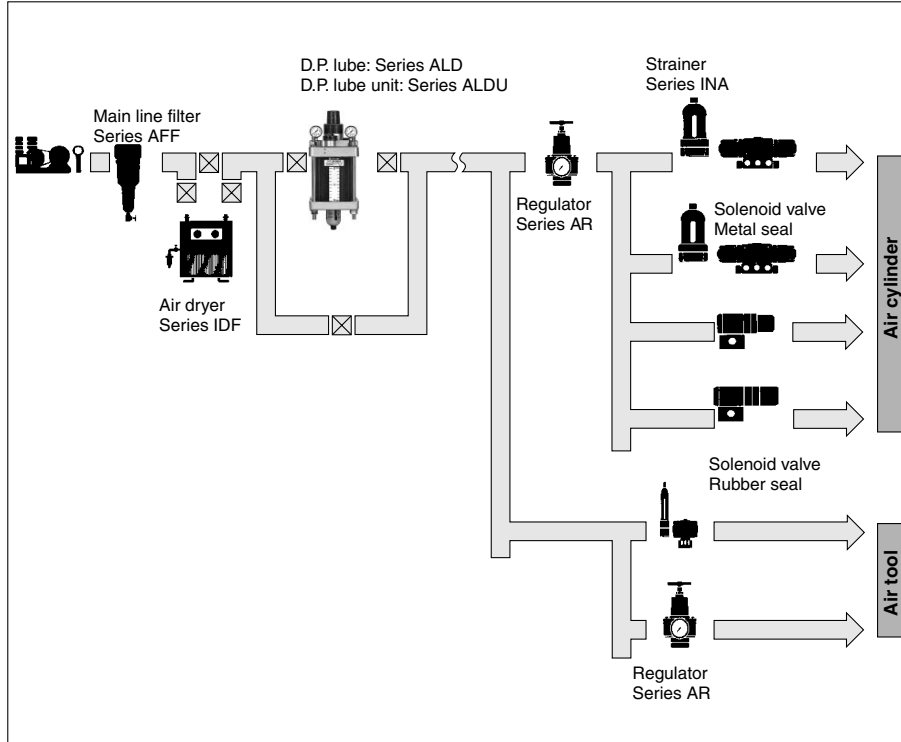

## Flow Characteristics

**ALD600-10** Condition: Inlet pressure 0.5 MPa, Pressure differential setting flow 250  $\ell$ /min (ANR)

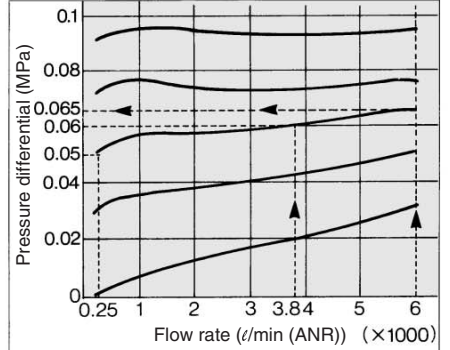

### How to read the graph (Example)

With the flow rate set to 250  $\ell$ /min (ANR) and the pressure differential set to 0.05 MPa, by changing the flow rate to 3800  $\ell$ /min (ANR) and 6000  $\ell$ /min (ANR), the pressure differential will change from the initial 0.05 MPa to 0.06 MPa, and to 0.065 MPa.

## ALD900-20

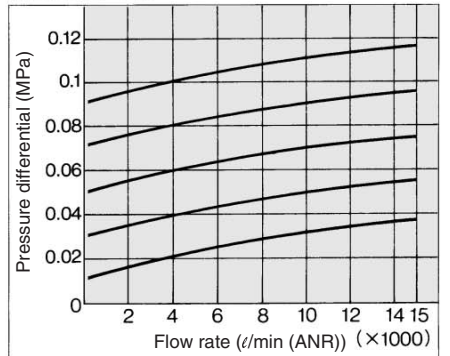

## Pressure Differential and Mist Generation

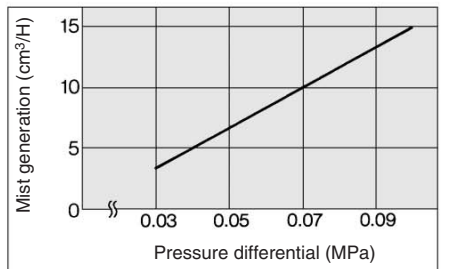

## Min. Flow for Pressure Differential Setting

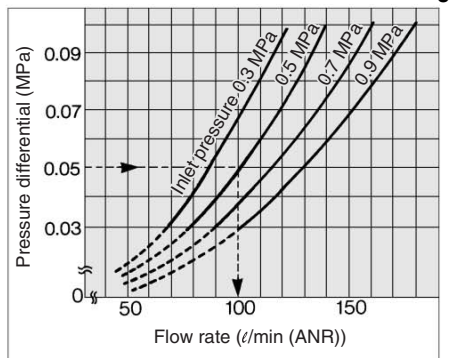

### How to read the graph (Example)

When the inlet pressure is 0.5 MPa, a flow rate that is greater than 102  $\ell$ /min(ANR) will be necessary to set the pressure differential to 0.05 MPa. Below this flow rate, the pressure differential cannot be set to 0.05 MPa.

## Circuit

### ALD600

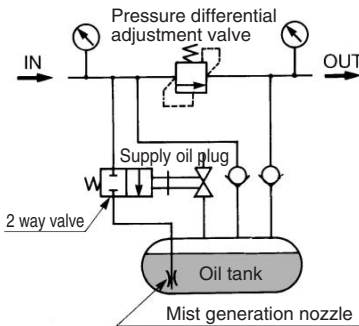

### ALD900

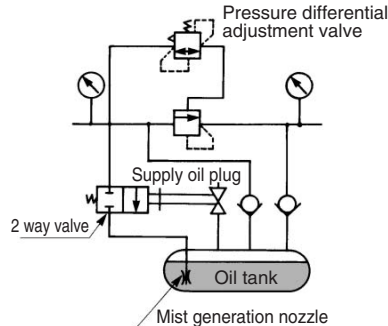

### ALDU600

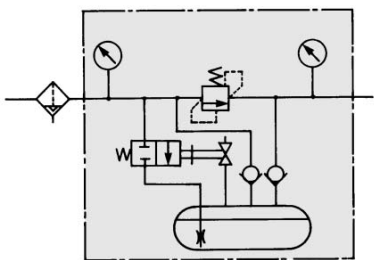

### ALDU900

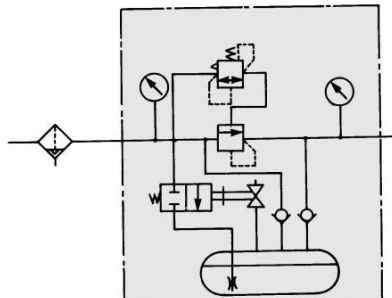

## Construction

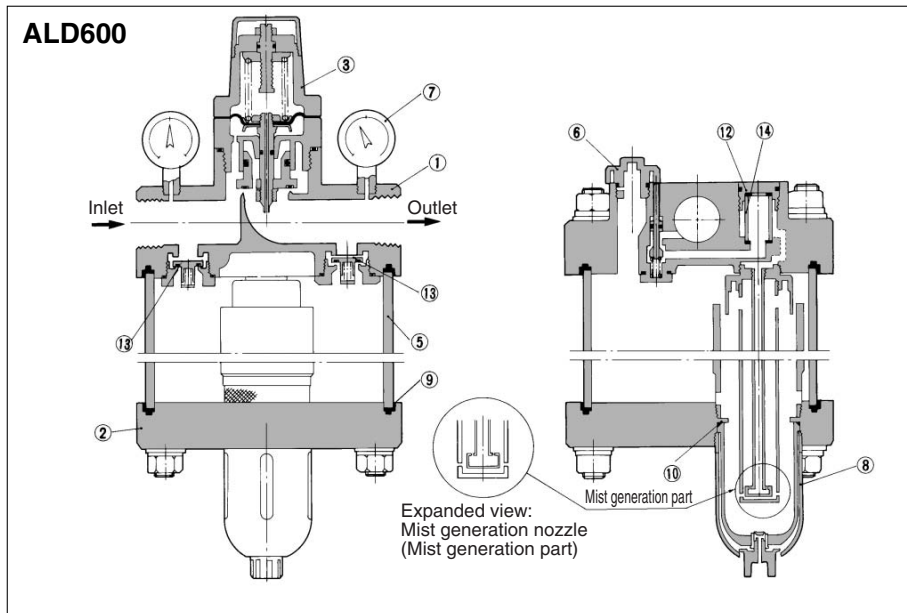

## ALD900

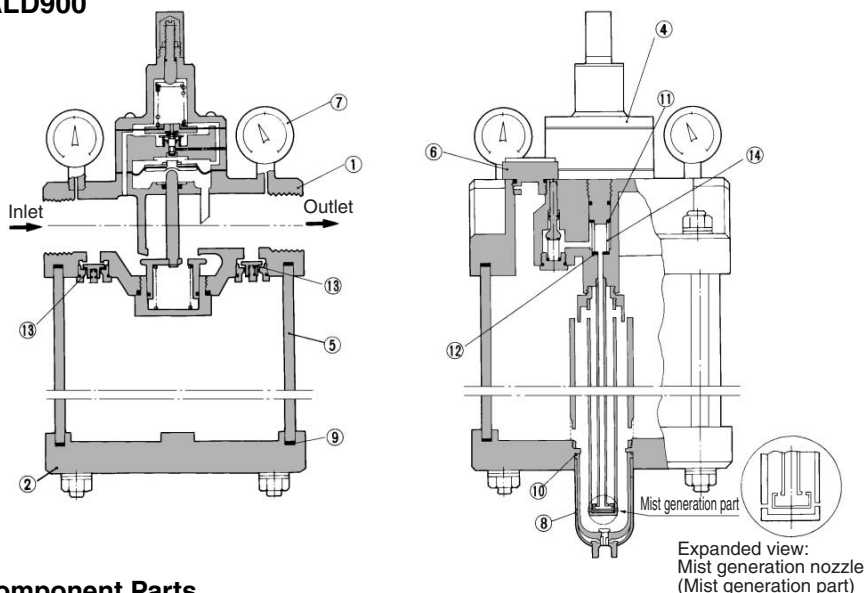

### Component Parts

No.	Description	Material	
		ALD600	ALD900
①	Body	Aluminum die-casted	Aluminum casted
②	Bottom cover	Aluminum die-casted	Aluminum casted

### Replacement Parts

No.	Description	Material	Part no.	
			ALD600	ALD900
③	Check valve assembly	—	12612AP	—
④	Pilot body assembly	—	—	12609AP
⑤	Bowl assembly	Glass fiber-inserted epoxy resin	126139-1A	126059-1A
⑥	Lubrication plug assembly	Zinc die-casted, NBR	126115AP	126115AP
⑦	Pressure gauge (2 pcs.)	—	GA46-10-01	GA46-10-02
⑧	Bowl assembly	—	AF11-2	AF11-2
⑨	Sealing (2 pcs.)	NBR	126140	126060
⑩	O-ring	NBR	11307	11307
⑪	Seal	NBR	—	126046
⑫	Seal	NBR	126047 (2)	126047
⑬	Check valve assembly (2 pcs.)	—	126127A	126022A
⑭	Filter element	Bronze	11294-70B	11294-70B

## ⚠ Precautions

Be sure to read before handling. Refer to pages 14-21-3 to 14-21-4 for Safety Instructions and Common Precautions.

### Caution on Design

#### ⚠ Warning

1. Epoxy resin containing glass fiber and polycarbonate is used in some parts of the D.P. Lube and the D.P. Lube Unit. These units cannot be used in an environment or in a location that is exposed to synthetic oil, thinner, acetone, alcohol, organic solvents such as ethylene chloride, chemicals such as sulfuric acid or nitric acid, cutting oil, kerosene, gasoline, or a threadlock agent, etc., because they will be damaged.

### Mounting/Adjustment

#### ⚠ Caution

1. Provide about 30 cm of space above and below the D.P. Lube or the D.P. Lube Unit to facilitate their maintenance and inspection.
2. When the line is stopped, do not adjust or set the differential pressure, as it could cause the differential adjustment valve to break.
3. When setting the pressure differential, if there is a fluctuation in the operating flow rate, set the pressure differential at the lower flow rate range.

### Piping

#### ⚠ Warning

1. The drain pipe for the air filter in the D.P. Lube Unit must have a minimum pipe bore of  $\phi 10$ , and a maximum length of 5 m. Avoid using a riser pipe because it could cause the auto-drain to malfunction.
2. If installing an air tank, install it on the IN side of the D.P. Lube Unit. If it is installed on the OUT side, the micromist could be arrested by the air tank, which could lead to insufficient feeding of oil.

### Maintenance

#### ⚠ Warning

1. Before removing the oil filler plug, loosen it two and a half turns to completely release the pressure inside the case. This will prevent the oil filler plug from flying out.

F.R.L.

AV

AU

AF

AR

IR

VEX

AMR

ITV

IC

VBA

VE□

VY1

G

PPA

AL

# Series ALD600/900

## D.P. Lube ALD600-□06 to 10, ALD900-□12 to 20

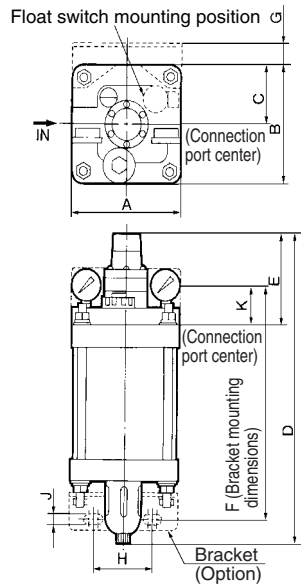

Model	Port size	A	B	C	D	E	Bracket dimensions				
							F	G	H	J	K
ALD600-□06 to 10	3/4, 1	175	175	87.5	460	135	345	32.5	95	14	57
ALD900-□12 to 20	1 1/4, 1 1/2, 2	250	250	125	613	209	419.2	0	120	14	49.6

## Related Products: Strainer

At the terminal of an air pressure line in which a D.P. Lube is used, install a strainer (filtration rate of 5 μm) upstream with a metal seal solenoid valve, which is susceptible to dust.

Mounting orientation is upward.

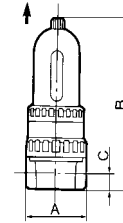

Model	Port size Rc	A	B	C
INA-11-402	1/4	63	141	15
INA-11-403	3/8	63	164.5	15
INA-11-404	1/4, 3/8, 1/2	80	170	15
INA-11-405	3/4	85	180	20
INA-11-406	3/4, 1	90	230	22
INA-11-407	1	100	251	22

## D.P. Lube Unit ALDU600-□06 to 10, ALDU900-□12 to 20

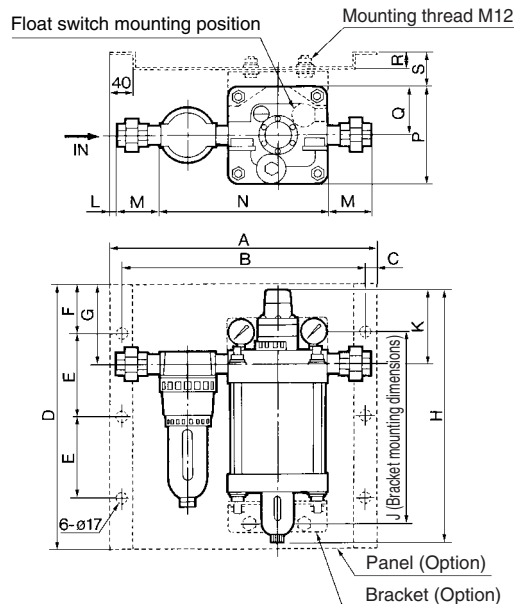

Model	Port size	A	B	C	D	E	F	G	H	J	K	L	M	N	P	Q	R	S
ALDU600-□06	3/4	470	430	20	480	150	90	145	460	345	135	43	67	283	175	87.5	30	62.5
ALDU600-□10	1											10	77	296				
ALDU900-□12	1 1/4	710	670	20	700	230	120	222	615	419.2	209	57	85	424	250	125	33.2	33.2
ALDU900-□14	1 1/2											51	90	424				
ALDU900-□20	2											16	100	476				