



# 3 Port Solenoid Valve Rubber Seal, Body Ported Series VZ100

## How to Order

**Body ported** VZ1 1 0 5 L [ ] M5 [ ]

**Type of actuation**

1	Normally closed (A) 2 3 1 (R)(P)
2	Normally open (A) 2 3 1 (R)(P)

Regarding VZ120, R port is a supply port.

**Rated voltage**

1	100 VAC, 50/60 Hz
2	200 VAC, 50/60 Hz
3*	110 VAC, 50/60 Hz
4*	220 VAC, 50/60 Hz
5	24 VDC
6*	12 VDC
9*	Other

\* Option

**Option**

F: With foot bracket

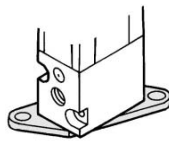

Note) Bracket is not mounted.

**Port size**







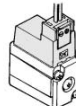

M5	M5 x 0.8
----	----------

**Light/Surge voltage suppressor**

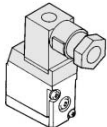
Nil	None
Z*	With light/surge voltage suppressor
S	With surge voltage suppressor

\* Not available for "GZ", "HZ" and "DOZ"

**Electrical entry**

Grommet	L plug connector	M plug connector		DIN terminal
<b>G:</b> Lead wire length 300 mm	<b>L:</b> With lead wire (Length 300 mm)	<b>M:</b> With lead wire (Length 300 mm)	<b>MN:</b> Without lead wire	<b>D:</b> With connector
				
<b>H:</b> Lead wire length 600 mm	<b>LN:</b> Without lead wire	<b>LO:</b> Without connector	<b>MO:</b> Without connector	<b>DO:</b> Without connector
				

\* "LN", "MN" type: With 2 sockets.

- V100
- SY
- SYJ
- VK
- VZ**
- VT
- VP
- VG
- VP
- S070
- VQ
- VKF
- VQZ
- VZ
- VS
- VFN

# Series VZ100

Low power consumption:  
1.8 W DC

Applicable for vacuum use  
-100 kPa



For manifold use, refer to the pages 4-6-8 to 4-6-11.



**Made to Order Specifications**  
(For details, refer to page 4-6-46.)

## Option

Description	Part no.	Note
With foot bracket	DXT170-34-1A	Mounting screw (M3 x 6)
Silencer	M5 AN120-M5 (ø8 x 17ℓ)	For valve unit (R port), Noise reduction: 21 dB or more, Effective area 5 mm <sup>2</sup>

## Specifications

Fluid	Air
Operating pressure range	Refer to the table below.
Ambient and fluid temperature (°C)	-10 to 50 (No freezing. Refer to page 4-18-4.)
Response time (ms) <sup>(1)</sup>	15 or less
Max. operating frequency (Hz)	15
Flow Characteristics	Refer to the table below.
Manual override	Non-locking push type
Lubrication	Not required
Mounting orientation	Unrestricted
Shock/Vibration resistance (m/s <sup>2</sup> ) <sup>(2)</sup>	300/50
Enclosure	Dustproof



Note 1) Based on dynamic performance test, JIS B 8374-1981. (Coil temperature: 20°C, at rated voltage, without surge suppressor)

Note 2) Impact resistance: No malfunction occurred when it is tested with a drop tester in the axial direction and at the right angles to the main valve and armature in both energized and de-energized states every once for each condition. (Values at the initial period)

Vibration resistance: No malfunction occurred in a one-sweep test between 45 and 1000 Hz. Test was performed at both energized and de-energized states in the axial direction and at the right angles to the main valve and armature. (Values at the initial period)

## Solenoid Specifications

\* Option

Electrical entry	Grommet (G)/(H), L plug connector (L), M plug connector (M), DIN terminal (D)		
Coil rated voltage (V)	AC50/60 Hz	100, 200, 24*, 48*, 110*, 220*	
	DC	24, 6*, 12*, 48*	
Allowable voltage fluctuation (%)	-15 to +10% of rated voltage		
Power consumption (W) Note)	DC	1.8 (With indicator light 2.1)	
[Current mA]		[24 VDC: 75 (With indicator light 87.5)]	
Apparent power (VA) Note)	AC	Inrush	4.5/50 Hz, 4.2/60 Hz [ 100 VAC: 45/50 Hz, 42/60 Hz ]
			200 VAC: 22.5/50 Hz, 21/60 Hz ]
[Current mA]	AC	Holding	3.5/50 Hz, 3/60 Hz [ 100 VAC: 35/50 Hz, 30/60 Hz ]
			200 VAC: 17.5/50 Hz, 15/60 Hz ]
Surge voltage suppressor	DC: Diode, AC: ZNR		
Indicator light	DC: LED (Red), AC: Neon bulb		



Note) At rated voltage

## Operating Pressure

Model	Type of actuation	Operating pressure range (MPa)	Vacuum specifications (MPa)		Port size	Weight (g) Note)
			1 (P) port	R port		
Body ported	VZ110	N.C.	0 to 0.7	-27 kPa to 0.6	M5 x 0.8	70
	VZ120	N.O.	0 to 0.5	-100 kPa to 0		



Note) Weight stands for grommet type

## Flow Characteristics

Model	Type of actuation	Port size	Flow characteristics						
			Supply side			Exhaust side			
			N.C.: 1 → 2 (P → A)	N.O.: 3 → 2 (R → A)		N.C.: 2 → 3 (A → R)	N.O.: 2 → 1 (A → P)		
			C [dm <sup>3</sup> /(s·bar)]	b	Cv	C [dm <sup>3</sup> /(s·bar)]	b	Cv	
Body ported	VZ110	N.C.	M5 x 0.8	0.11	0.026	0.023	0.19	0.071	0.042
	VZ120	N.O.		0.19	0.071	0.042	0.13	0.18	0.031

## Construction

### VZ110 (N.C.)

JIS Symbol

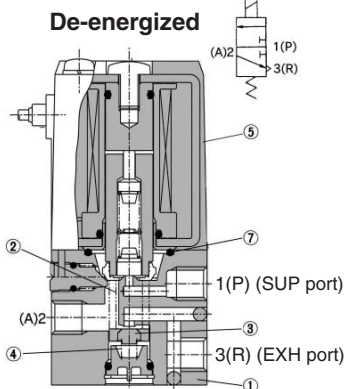

### VZ120 (N.O.)

JIS Symbol

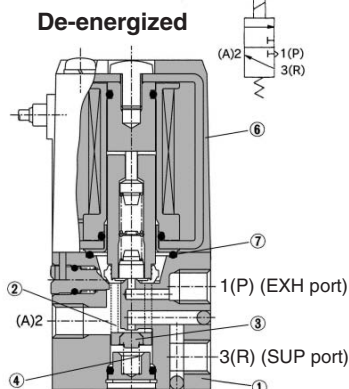

## Component Parts

No.	Description	Material	Note
①	Body	ZDC	Platinum silver
②	Push rod	Resin	
③	EXH poppet	NBR	
④	N.C. Back up spring	Stainless steel	
	N.O. Poppet spring		

## Replacement Parts

No.	Description	Part no.	Material	Note
⑤	Solenoid assembly	DXT170-A-□□□	Epoxy Stainless steel	VZ110
⑥	Solenoid assembly	DXT170-E-□□□	Epoxy Stainless steel	VZ120
⑦	O-ring	13 x 11 x 1	NBR	Common with Series VZ <sub>3</sub> 00

# 3 Port Solenoid Valve Rubber Seal, Body Ported **Series VZ100**



**Body Ported**

**Grommet (G), (H)**  
VZ1□0-□<sup>G</sup>□-M5(-F)

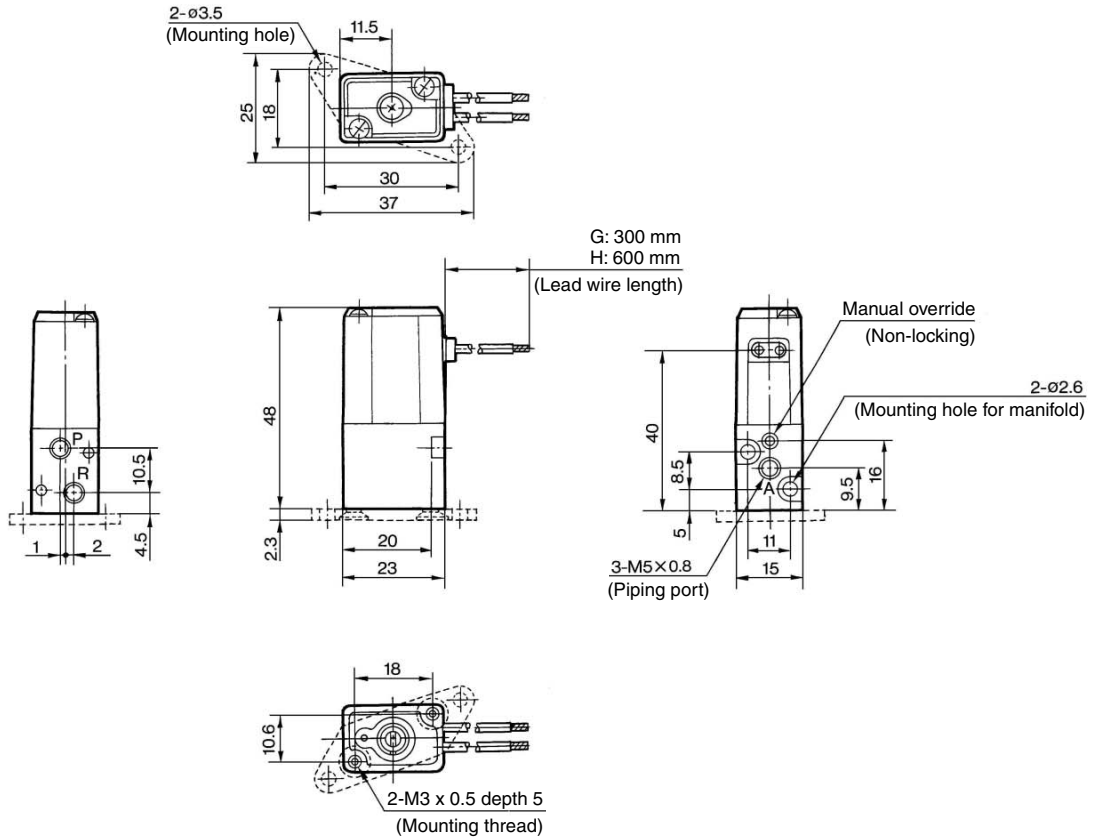

**L plug connector (L)**  
VZ1□0-□L□-M5

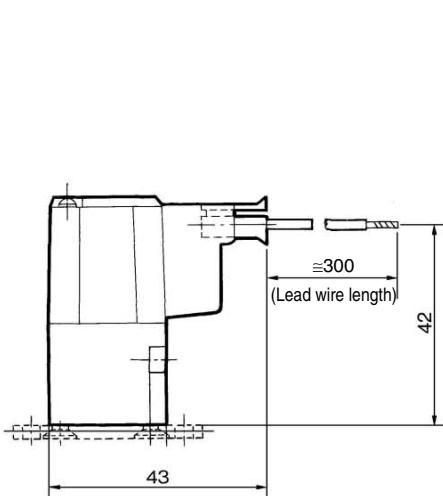

**M plug connector (M)**  
VZ1□0-□M□-M5

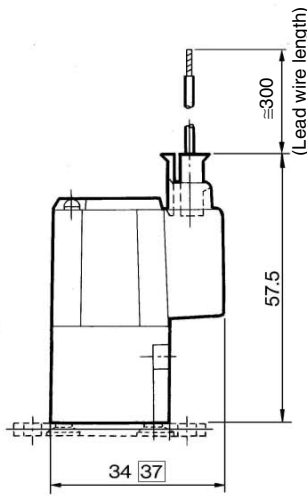

**DIN terminal (D)**  
VZ1□0-□D□-M5

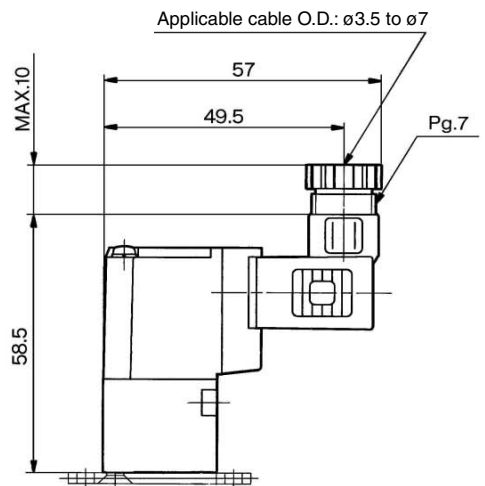

□: With light/surge voltage suppressor

V100

SY

SYJ

VK

**VZ**

VT

VP

VG

VP

S070

VQ

VKF

VQZ

VZ

VS

VFN

# Manifold Specifications



## Manifold Specifications

Model		VV3Z1-01-□1	VV4Z1-20-□1
Manifold type		Single base/B mount	
P(SUP)/R(EXH)		Common SUP/Common EXH	
Valve stations		2 to 20 stations <sup>(1)</sup>	
A port	Location	Valve	
Porting specifications	Direction	Top	
	Port size	1(P), 3(R) port	M5 x 0.8
		2(A) port	M5 x 0.8

- Note 1) If there are more than 10 stations, exhaust from both sides of manifold.  
 Note 2) Not able to use VZ120 and VZ110 on the same manifold base.  
 Note 3) In the case of VZ120, supply air to 3 (R) port and exhaust from 1(P) port.

## Flow Characteristics

Manifold	Port size		Flow characteristics					
			1 → 2 (P → A)			2 → 3 (A → R)		
	1(P), 3(R) Port	A, B Port	C [dm <sup>3</sup> /(s·bar)]	b	Cv	C [dm <sup>3</sup> /(s·bar)]	b	Cv
VV3Z1-01-□1	M5 x 0.8	M5 x 0.8	0.13	0.13	0.03	0.22	0.074	0.048
VV4Z1-20-□1	1/8	M5 x 0.8	0.13	0.1	0.03	0.22	0.15	0.052

## How to Order Manifold

Instruct by specifying the valves and blanking plate assembly to be mounted on the manifold along with the manifold base model no.

- (Example) VV3Z1-01-031.....1 pc. (Manifold base)  
 \*VZ110-5LZ-M5.....2 pcs. (Valve)  
 \*DXT170-25-1A.....1 pc. (Blanking plate assembly)

↳ The asterisk denotes the symbol for assembly. Prefix it to the part nos. of the solenoid valve, etc.

## Option

### Combinations of Solenoid Valve, Gasket and Manifold

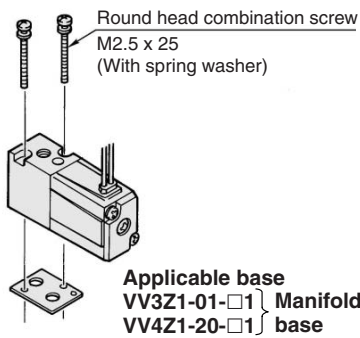

### Blanking Plate Assembly

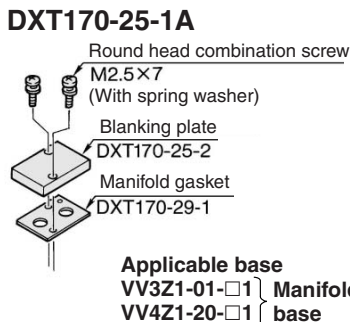

### Individual EXH Spacer Assembly

#### DXT170-48-1A

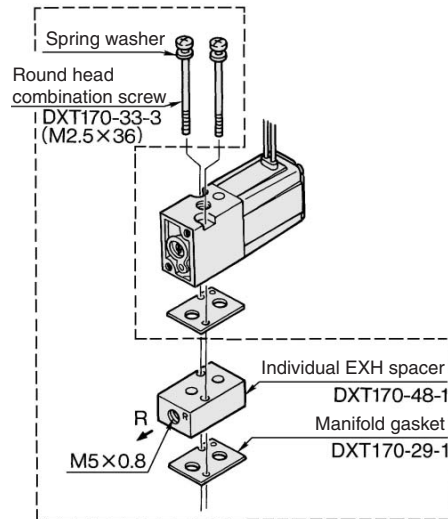

Applicable base  
VV3Z1-01-□1 } Manifold  
VV4Z1-20-□1 } base

### Individual SUP Spacer Assembly

#### DXT170-44-1A

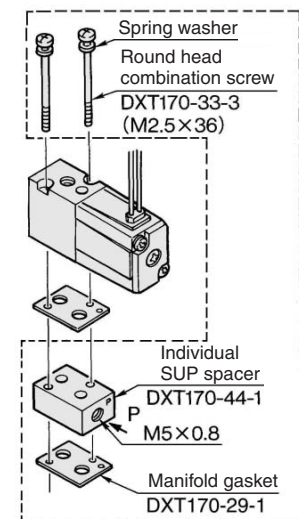

Applicable base  
VV3Z1-01-□1 } Manifold  
VV4Z1-20-□1 } base

**Caution** Mounting Screw Tightening Torques

M2.5: 0.45 N·m

## Warning

When mounting a solenoid valve on the manifold base or sub-plate, etc., the mounting direction is determined. If mounted in the wrong direction, the equipment to be wired might result in malfunction. Refer to dimensions of this catalog and use caution to the mounting direction.

# 3 Port Solenoid Valve Rubber Seal, Body Ported **Series VZ100**

## Type 01

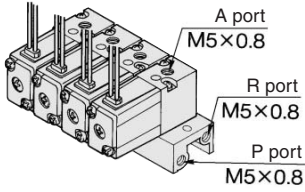

### How to Order

**VV3Z1 - 01 - 05 1 -**   

Stations	
02	2 stations
⋮	⋮
20	20 stations

#### Option

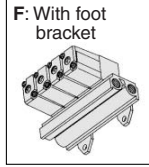

\* Bracket is not mounted.

**Applicable solenoid valve**  
VZ110-□□□-M5  
VZ120-□□□-M5  
**Applicable blanking plate assembly**  
DXT170-25-1A  
**Individual EXH spacer assembly**  
DXT170-48-1A  
**Individual SUP spacer assembly**  
DXT170-44-1A



Note) • If there are more than 10 stations, exhaust from both sides of manifold.  
• It is not able to use VZ110 and VZ120 on the same manifold base.

V100

SY

SYJ

VK

**VZ**

## Type 20

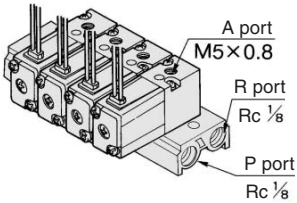

### How to Order

**VV4Z1 - 20 - 05 1 -**      

Stations	
02	2 stations
⋮	⋮
20	20 stations

#### Thread type

Nil	Rc
00F	G
00N	NPT
00T	NPTF

#### Option

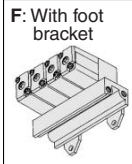

\* Bracket is not mounted.

**Applicable solenoid valve**  
VZ110-□□□-M5  
VZ120-□□□-M5  
**Applicable blanking plate assembly**  
DXT170-25-1A  
**Individual EXH Spacer assembly**  
DXT170-48-1A  
**Individual SUP Spacer assembly**  
DXT170-44-1A



Note) • If there are more than 10 stations, supply air to SUP port on both sides of the manifold and exhaust from EXH port on both sides of the manifold.  
• It is not able to use VZ110 and VZ120 on the same manifold base.

VT

VP

VG

VP

S070

VQ

VKF

VQZ

VZ

VS

VFN



# 3 Port Solenoid Valve Rubber Seal, Body Ported **Series VZ100**

## Type 20 Manifold: Top Ported

VV4Z1-20-Stations 1(-F)  
Grommet (G), (H)

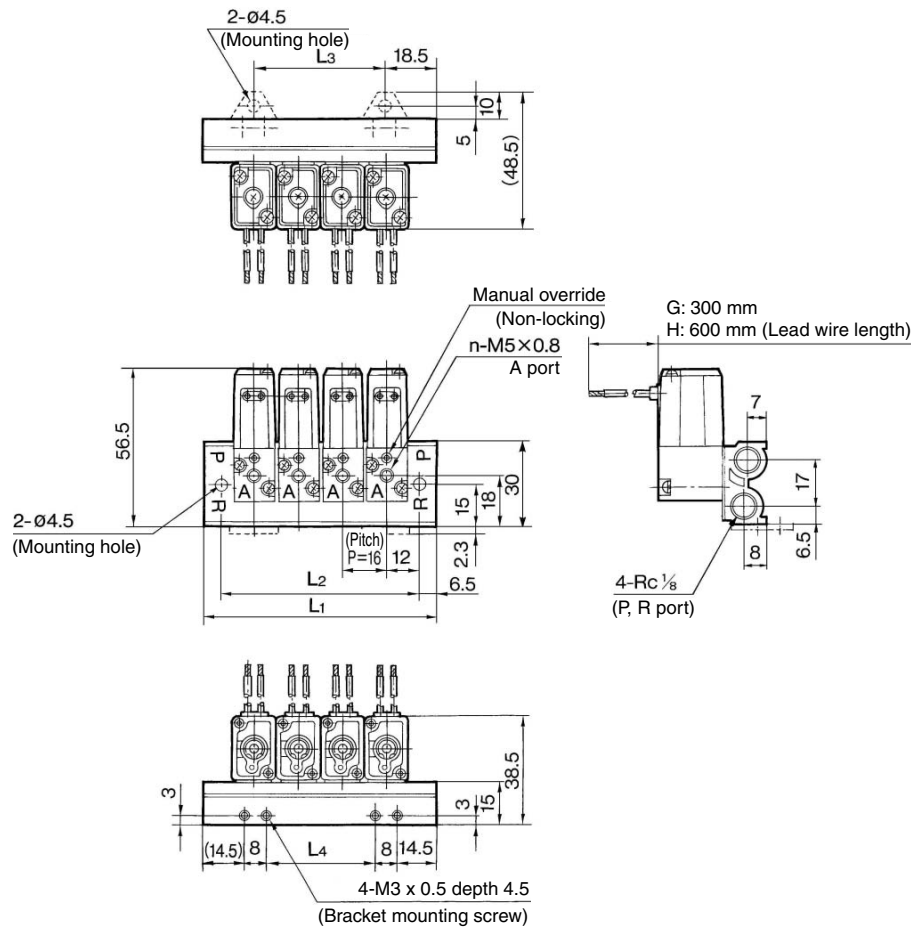

Stations n	2	3	4	5	6	7	8	9	10	11	12	13	14	15	16	17	18	19	20
L1	53	69	85	101	117	133	149	165	181	197	213	229	245	261	277	293	309	325	341
L2	40	56	72	88	104	120	136	152	168	184	200	216	232	248	264	280	296	312	328
L3	16	32	48	64	80	96	112	128	144	160	176	192	208	224	240	256	272	288	304
L4	8	24	40	56	72	88	104	120	136	152	168	184	200	216	232	248	264	280	296

### L plug connector (L)

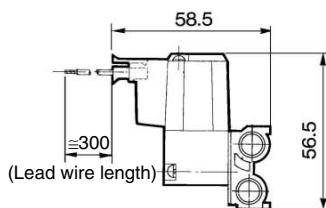

### M plug connector (M)

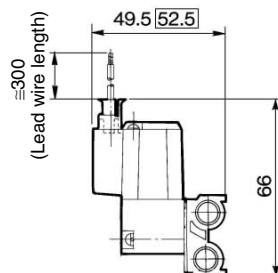

### DIN terminal (D)

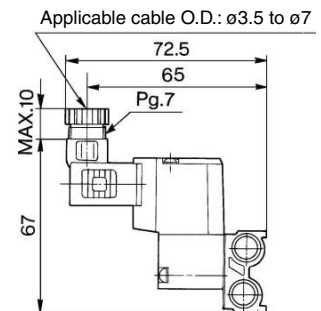

: With light/surge voltage suppressor

V100

SY

SYJ

VK

**VZ**

VT

VP

VG

VP

S070

VQ

VKF

VQZ

VZ

VS

VFN

# Series VZ

# Made to Order Specifications:

## 1. Solenoid Valve: Opposite Mounting of Solenoid Assembly

### Applicable solenoid valve series

VZ100/300/500

### Model no.

VZ1  0 -    (-  ) - X1

VZ<sub>5</sub><sup>3</sup>   -    (-  ) - X1

• Entry is the same as standard products.

### Dimensions: VZ110-□G-M5-X1

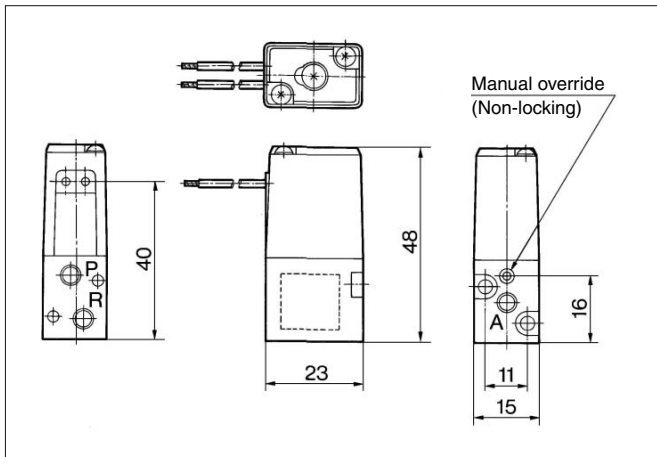

## 2. Solenoid Valve: External Pilot Specifications

● Applicable for individual use of body ported external pilot type

### Applicable solenoid valve series

VZ300/500

### Model no.

VZ<sub>5</sub><sup>3</sup>  2R -     (-  ) - X20

• Entry is the same as standard products.

### Specifications

Operating pressure range (MPa)	Main pressure	-100 kPa to 0.7
	External pilot pressure	0.15 to 0.7
Pilot exhaust method	Pilot valve individual exhaust	

### Dimensions

VZ300: 8 mm longer in total length

VZ500: 8 mm longer in total length

### Dimensions: VZ312R-□G-M5-X20

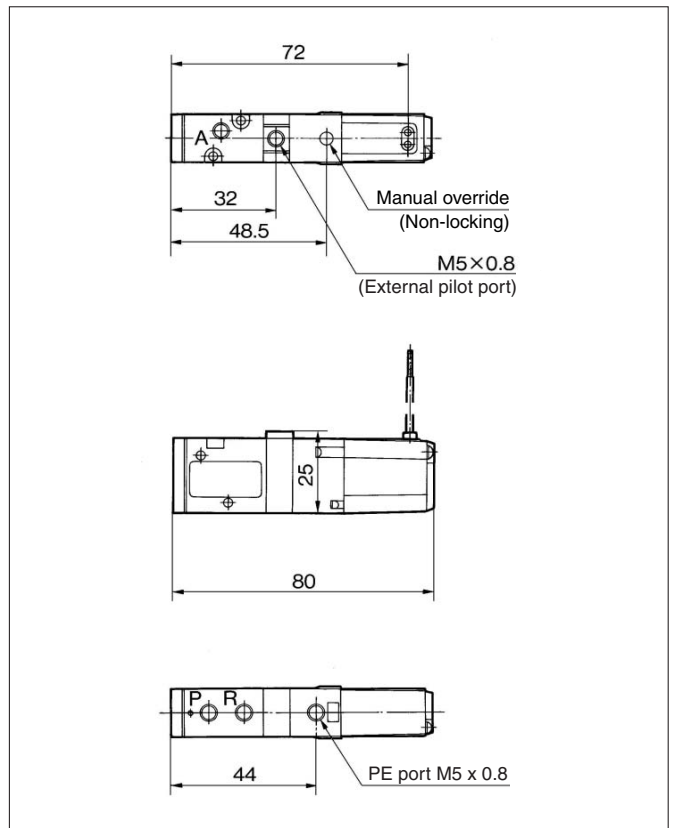

## 3/2 DIRECT ACTING SOLENOID VALVE 10-32Nom PORTED

### TECHNICAL SPECIFICATIONS

- ✓ N/O or N/C Option
- ✓ 10-32Nom Body Ported, possible to Manifold Mount
- ✓ Cv 0.05
- ✓ Optional Lamp and Surge Voltage Suppressor
- ✓ Suitable for Pressure or Vacuum

Fluid	Air
Ambient and Fluid Temperature	Max 50°C / 122°F
Response Time	15ms or less
Max Operating Frequency	15c/s
Manual Override	Non-locking type
Lubrication	Not required (Use turbine oil ±1 (ISO VG32) if lubrication is provided)
Enclosure	Dust Proof

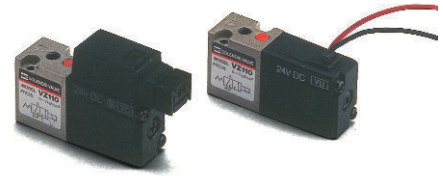

### SOLENOID SPECIFICATIONS

Electrical Entry	Grommet (G), Plug connector (M)		
Voltages	AC	240V, 110V, 24V	
	DC	12V, 24V	
Allowable Voltage	-15~+10% of rated voltage		
Coil Insulation	Class E or equivalent (120°C)		
Temperature Rise	45°C or less / 113°F or less		
Power Consumption	DC	1.8W/2.1W (W/LED)	
Apparent Power	AC	Inrush	4.5VA/50Hz, 4.2VA/60Hz
		Holding	3.5VA/50Hz, 3VA/60Hz
Surge Voltage Suppressor	DC: Diode, AC: ZNR		
Indicator Light	DC: LED (Red), AC: Neon lamp		

### SYMBOLS

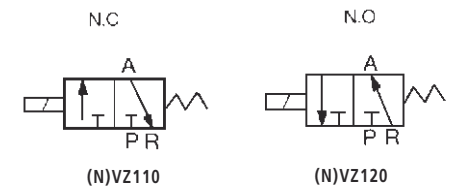

### ACCESSORIES

#### (N)VZ100 SOLENOID VALVE

- DXT170-123-A-30 ..... Plug with 3m lead
- DXT170-34-1A ..... Foot bracket with screws

### FLOW SPECIFICATIONS

Body Type	Model	Type Of Actuation	Operating Pressure Range kgf/cm <sup>2</sup>	Vacuum Application		Effective Orifice mm <sup>2</sup> (Cv Factor)	Port Size	Weight
				P Port	R Port			
Body Ported	(N)VZ110-**-M5	NC	0 ~ 7MPa 0 ~ 100PSI	22in-Hg 0~85PSI	VAC ~0PSI	P->A 0.6 (0.034) A->R 0.9 (0.05)	10-32Nom (M5x0.8)	0.15g
	(N)VZ110-**-M5	NO	0 ~ 5MPa 0 ~ 70PSI	22in-Hg 0~85PSI	VAC ~55PSI	R->A 0.6 (0.034) A->P 0.6 (0.034)		

Note: In case of (N)VZ120 Supply Air to 'R' Port. "P" Port will be the Exhaust Port.



Observe Operating Pressure Ranges - see Technical Specifications for details

### HOW TO ORDER

#### (N)VZ100 SOLENOID VALVE

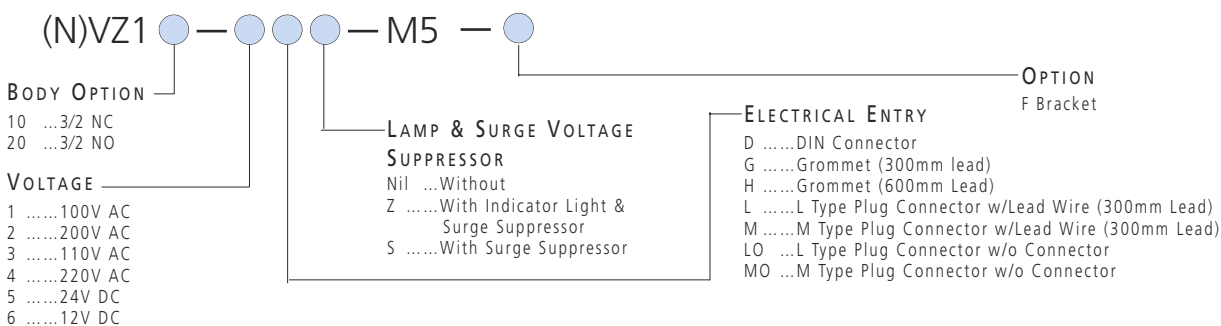

DIMENSIONS  
SEE NEXT PAGE

## DIMENSIONS (N)VZ100 BODY PORTED GROMMET TYPE

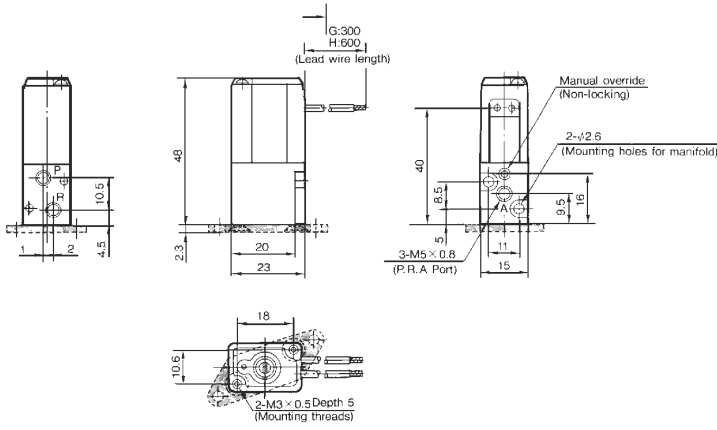

## DIMENSIONS (N)VZ100 BODY PORTED MN PLUG TYPE

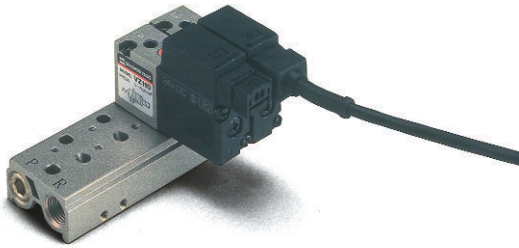
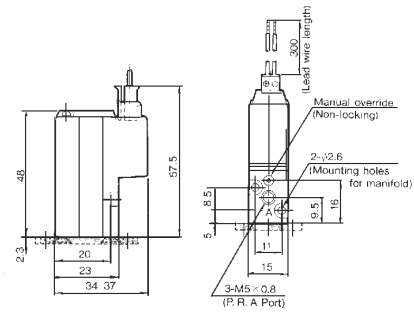

## SERIES (N)VZ100 MANIFOLDS

2 - 9 station manifold with a common supply and exhaust.

### HOW TO ORDER

MANIFOLD TYPE 20 TOP PORTED

(N)VV4Z1—20— 1

STATIONS  
02 ...2 Stations  
to  
20 ...20 Stations

THREAD TYPE  
- .....PT  
00T ...NPTF

OPTION  
F .....Bracket

## DIMENSIONS MANIFOLD TYPE 20 TOP PORTED M PLUG TYPE

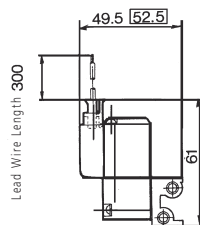

## DIMENSIONS MANIFOLD TYPE 20 TOP PORTED GROMMET TYPE

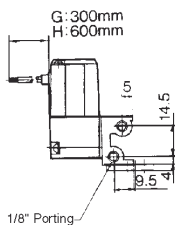
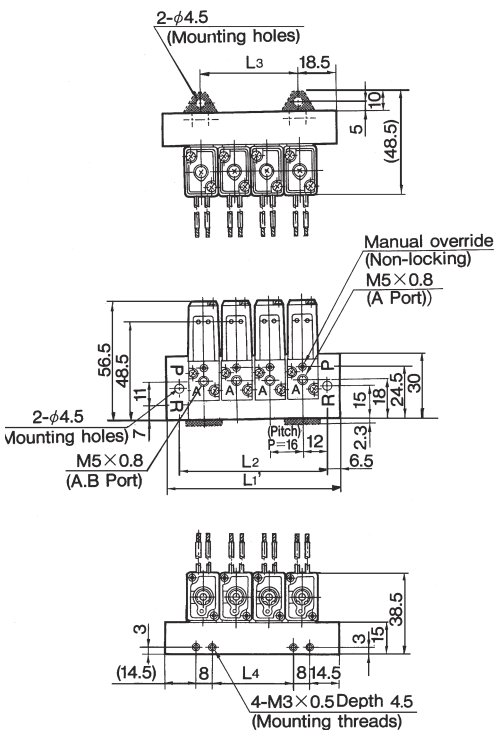

### ACCESSORIES

MANIFOLD TYPE 20 TOP PORTED

DXT170-25-1A .....Blanking Plate Assembly

Stations (n)	2	3	4	5	6	7	8	9	10
L1	53	69	85	101	117	133	149	165	181
L2	40	56	72	88	104	120	136	152	168
L3	16	32	48	64	80	96	112	128	144
L4	8	24	40	56	72	88	104	120	136

SEE INSIDE FRONT COVER FOR  
DETAILS OF YOUR LOCAL SALES OFFICE



FOR FURTHER TECHNICAL  
DETAILS ON THIS  
PRODUCT REQUEST  
CATALOG REFERENCE  
E120