

3 Port Solenoid Valve

Series VKF300

Rubber Seal Direct Operated Poppet Type



VV061
VV100
V100
S070
VQD
VQD-V
VKF
VK
VT
VS4
VS3

Compact yet provides a large flow capacity

Body width 18 mm

Available in vacuum applications (-101.2 kPa)

Can be used in vacuum/release circuits

Universal porting

N.C./N.O. type can be switched by supplying air to port 1 (P) or 3 (R). 2 way valves and selector valves can also be freely used.

Various manifold piping directions

Output port: Manifold set-up allowing 360° rotation of 2 (A) entry direction (in 90° increments)

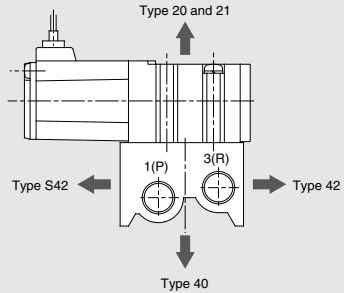

Easy manual operation

Since manual overrides are located in 2 directions, on the top and on the side of the valve, manual override operation is possible and is unaffected by mounting space and piping direction, etc.

Ozone resistant (Series 80-)

FKM (Fluororubber) is used for the fluid-contact rubber materials, allowing for use even in ozone environments.

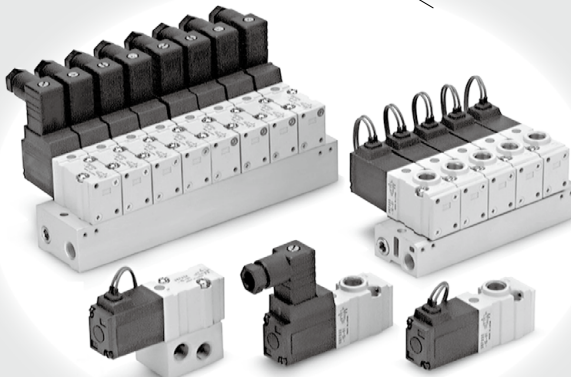
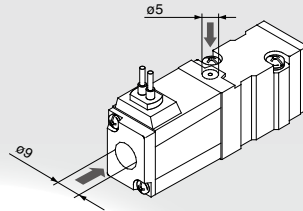

3 Port Solenoid Valve Direct Operated Poppet Type Series VKF300



How to Order Valves

Rated voltage

1	100 VAC, 50/60 Hz
2	200 VAC, 50/60 Hz
3*	110 VAC, 50/60 Hz
4*	220 VAC, 50/60 Hz
5	24 VDC
6*	12 VDC
7*	240 VAC, 50/60 Hz

* Semi-Standard
For other rated voltages,
please consult with SMC.

Electrical entry

G: Grommet (Lead wire length: 300 mm)	H: Grommet (Lead wire length: 600 mm)	D: DIN terminal	DO: DIN terminal* (Without connector)
--	--	------------------------	---

* Refer to page 1978 for Connector part no.

Port size

M5	M5 x 0.8
01	Rc 1/8 (A port)

Thread type

NII	RC
F	G
N	NPT
T	NPTF

* For the port size
01 only.

Body ported
(Single type)

VKF332 □ — 5 G □ — M5 □ — □ (With bracket)

Body ported
(For manifold)

VKF333 □ — 5 G □ — M5 □ — □

Base mounted

VKF334 □ — 5 G □ — 01 □ — □

CE-compliant

NII	—
Q	CE-compliant

Valve option

V	For vacuum
Y*	For low power consumption
W*	For vacuum/low power consumption
E*	Continuous duty type

* Applicable voltage: 12 and 24 VDC

Port size

01	Rc 1/8 (With sub-plate)
NII	Without sub-plate

Light/Surge voltage suppressor

NII	None
S	With surge voltage suppressor
Z	With light/surge voltage suppressor (Type "D" only)

* Since the indicator light is built in the
connector, thus, "DOZ" is not available.

Flow Characteristics/Weight

Valve model	Operating pressure range (MPa)	Port size	Flow characteristics						Weight (g)	
			1 → 2 (P → A)			2 → 3 (A → R)			Grommet	DIN terminal
			C [dm ³ /(s·bar)]	b	Cv	C [dm ³ /(s·bar)]	b	Cv		
Body ported	0 to 0.7	M5 x 0.8 Rc 1/8	0.67	0.10	0.15	0.41	0.39	0.11	80 ⁽¹⁾	90 ⁽¹⁾
			0.56	0.13	0.13	0.32	0.25	0.09		
			0.56	0.13	0.13	0.32	0.25	0.09		
			0.67	0.10	0.15	0.41	0.39	0.11		
Base mounted (With sub-plate)	-101.2 kPa to 0.1		0.56	0.13	0.13	0.32	0.25	0.09	120	130
			0.68	0.13	0.15	0.59	0.31	0.14		
			0.56	0.13	0.13	0.32	0.25	0.09		
			0.56	0.13	0.13	0.32	0.25	0.09		
	0 to 0.7	0.68	0.13	0.15	0.59	0.31	0.14			
		0.56	0.13	0.13	0.32	0.25	0.09			
		0.56	0.13	0.13	0.32	0.25	0.09			
		0.68	0.13	0.15	0.59	0.31	0.14			
-101.2 kPa to 0.1	0.56	0.13	0.13	0.32	0.25	0.09				
	0.56	0.13	0.13	0.32	0.25	0.09				

Note 1) VKF33□: Add 10 g to each when equipped with bracket.

3 Port Solenoid Valve Direct Operated Poppet Type *Series VKF300*

Standard Specifications



Body ported



Base mounted

Symbol

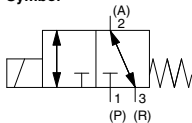

Valve specifications	Type of actuation		Direct operated type 2 position single solenoid
	Fluid		Air
	Ambient and fluid temperature		Max. 50°C
	Response time (at 0.5 MPa) ⁽¹⁾		10 ms or less (Standard), 15 ms or less (Low power consumption type)
	Manual override		Non-locking push type
	Lubrication		Not required (Use turbine oil Class 1 ISO VG32, if lubricated.)
Electricity specifications	Mounting orientation		Unrestricted
	Impact/Vibration resistance ⁽²⁾		300/50 m/s ²
	Enclosure		Dustproof
	Electrical entry		Grommet (G), DIN terminal (D)
	Rated voltage	AC	100, 110, 200, 220, 240 V
		DC	6, 12, 24, 48 V
	Allowable voltage fluctuation		±10% of rated voltage
	Apparent power (AC)	Inrush	9.5 VA/50 Hz, 8 VA/60 Hz
		Holding	7 VA/50 Hz, 5 VA/60 Hz
	Power consumption (DC)	Wo indicator light	4 W (Standard), 2 W (Low power consumption type)
W/ indicator light		4.3 W (Standard), 2.3 W (Low power consumption type)	
Surge voltage suppressor	AC	Varistor	
	DC	Diode (Varistor for 12 VDC or less)	
	AC	Neon bulb	
Indicator light	DC	LED	

Note 1) Based on dynamic performance test, JIS B 8374-1981. (Coil temperature: 20°C, at rated voltage, without surge voltage suppressor)

* When equipped with DC solenoid/surge voltage suppressor, a delay of about 20 to 30 msec. occurs in the OFF response time.

Note 2) Impact resistance: No malfunction occurred when it is tested with a drop tester in the axial direction and at the right angles to the main valve and armature in both energized and de-energized states every once for each condition. (Values at the initial period)

Vibration resistance: No malfunction occurred in a one-sweep test between 45 and 2000 Hz. Test was performed at both energized and de-energized states in the axial direction and at the right angles to the main valve and armature. (Values at the initial period)

Construction

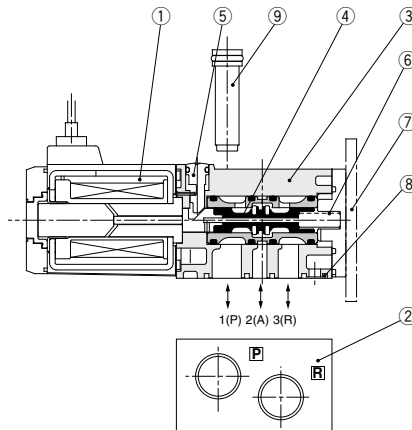

Component Parts

No.	Description	Material	Note
①	Solenoid coil assembly	—	
②	Sub-plate	Aluminum die-casted	For VKF334: VKF300-S-01
③	Body	Aluminum die-casted	
④	Spool/Sleeve	Aluminum	
⑤	Manual override	Resin	
⑥	Return spring	Stainless steel	
⑦	Bracket assembly	Steel	For VKF332: VKF300-13A-2
⑧	Gasket assembly (With mounting screw)	—	For VKF333: VKF300-11A-2 For VKF334: VKF300-11A-1
⑨	Bushing assembly	Resin	For VKF333: VKF300-6A-1 2 sets per unit required

Series VKF300

Dimensions: Single Type

Body ported

Grommet: VKF332□-□G-M5
01

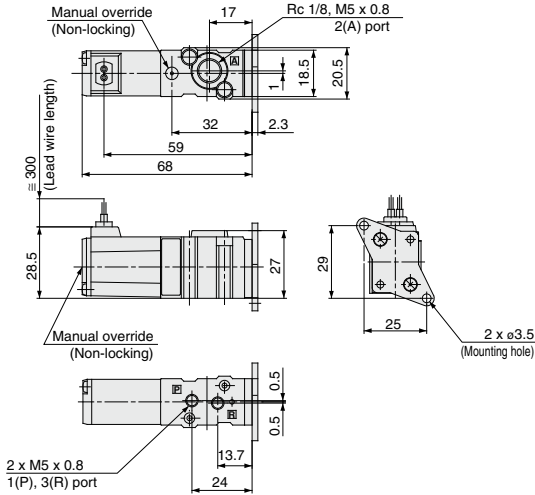

DIN terminal: VKF332□-□D-M5
01

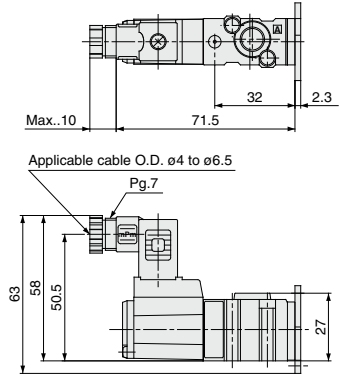

Refer to grommet type for other dimensions.

Base mounted

Grommet: VKF334□-□G-01

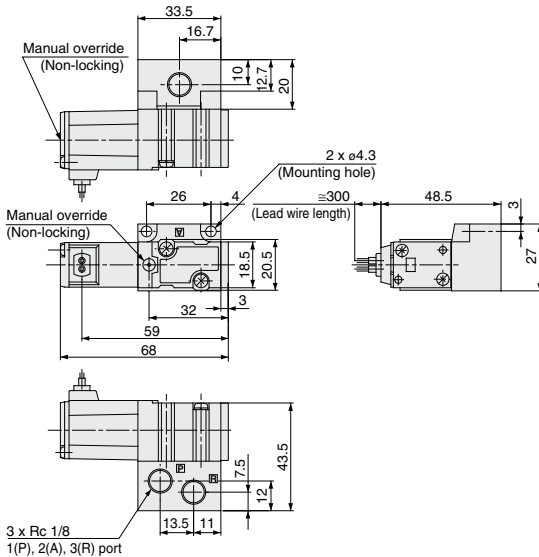

DIN terminal: VKF334□-□D-01

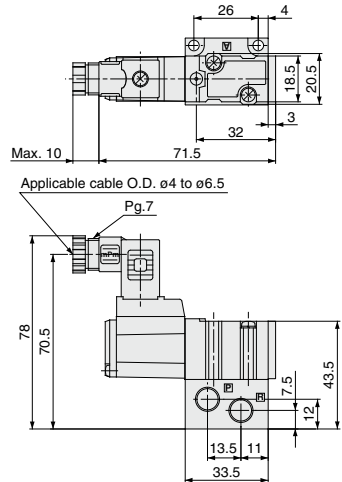

Refer to grommet type for other dimensions.

How to Order Manifold

Body ported

Common SUP/Common EXH

Type 20: Body ported (A port top ported)

2(A) port:
Rc 1/8, M5 x 0.8

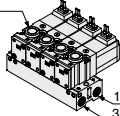

1(P) port: Rc 1/8
3(R) port: Rc 1/8

How to Order

VV3KF3-20-05

Valve stations

01	1 station
:	:
20	20 stations

Option

Nil	None
F	With bracket (Not mounted)

Thread type

Nil	Rc
00F	G
00N	NPT
00T	NPTF

Applicable solenoid valve
VKF333□-□□□-M5 (-Q)
VKF333□-□□□-01 (-Q)

Applicable blanking plate assembly
VK300-42-1A

Bracket
VK300-43-1A

CE-compliant

Nil	—
Q	CE-compliant

VV061

VV100

V100

S070

VQD

VQD-V

VKF

VK

VT

VS4

VS3

Common SUP/Individual EXH

Type 21: Body ported (A port top ported)

2(A) port:
Rc 1/8, M5 x 0.8

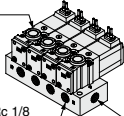

3(R) port: Rc 1/8

1(P) port: Rc 1/8

How to Order

VV3KF3-21-05

Valve stations

01	1 station
:	:
20	20 stations

Thread type

Nil	Rc
00F	G
00N	NPT
00T	NPTF

Applicable solenoid valve
VKF333□-□□□-M5 (-Q)
VKF333□-□□□-01 (-Q)

Applicable blanking plate assembly
VK300-42-1A

CE-compliant

Nil	—
Q	CE-compliant

Base mounted

Common SUP/Common EXH

Type 40: Base mounted (A port bottom ported)

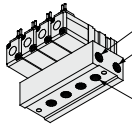

1(P) port: Rc 1/8
3(R) port: Rc 1/8

2(A) port: Rc 1/8

How to Order

VV3KF3-40-05-01

Valve stations

01	1 station
:	:
20	20 stations

Port size
01 Rc 1/8

Thread type

Nil	Rc
F	G
N	NPT
T	NPTF

Applicable solenoid valve
VKF334□-□□□ (-Q)

Applicable blanking plate assembly
VK300-42-1A

Bracket
VK300-43-1A

CE-compliant

Nil	—
Q	CE-compliant

Option

Nil	None
F	With bracket (Not mounted)

Type 42: Base mounted (A port side ported)

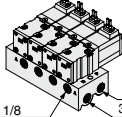

2(A) port: Rc 1/8

1(P) port: Rc 1/8
3(R) port: Rc 1/8

How to Order

VV3KF3-42-05-01

Solenoid direction

Nil	Solenoid on opposite A port
S	Solenoid on same side as A port

Applicable solenoid valve
VKF334□-□□□ (-Q)

Applicable blanking plate assembly
VK300-42-1A

CE-compliant

Nil	—
Q	CE-compliant

Type S42 (Solenoid on same side as port A)

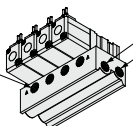

2(A) port: Rc 1/8

1(P) port: Rc 1/8
3(R) port: Rc 1/8

Valve stations

01	1 station
:	:
20	20 stations

Thread type

Nil	Rc
F	G
N	NPT
T	NPTF

Port size

01	Rc 1/8
C4	ø4 cassette
C6	ø6 cassette

Series VKF300

Dimensions: Manifold

Body ported

Type 20 Manifold Common SUP, Common EXH/Top Ported

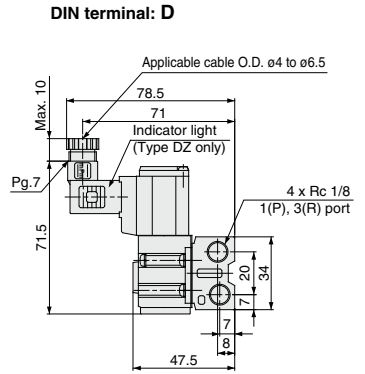
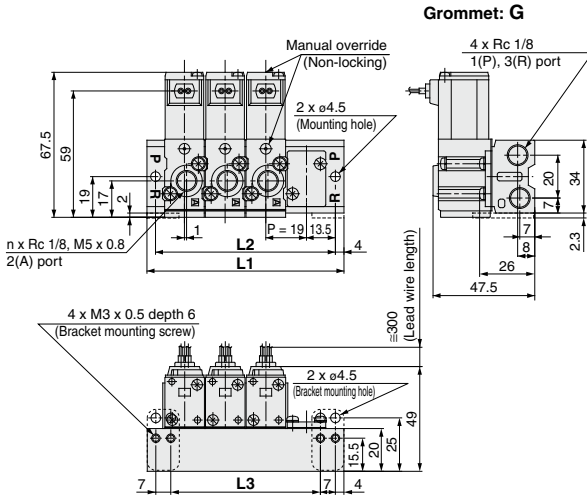

L Dimension

n	1	2	3	4	5	6	7	8	9	10	11	12	13	14	15	16	17	18	19	20
L1	35	54	73	92	111	130	149	168	187	206	225	244	263	282	301	320	339	358	377	396
L2	27	46	65	84	103	122	141	160	179	198	217	236	255	274	293	312	331	350	369	388
L3	13	32	51	70	89	108	127	146	165	184	203	222	241	260	279	298	317	336	355	374

n: Stations

Type 21 Manifold Common SUP, Individual EXH/Top Ported

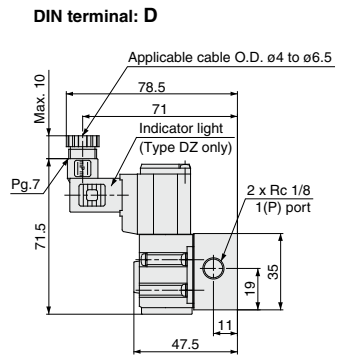
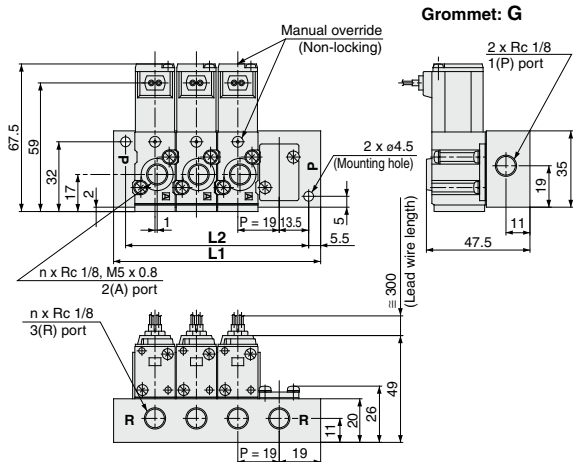

L Dimension

n	1	2	3	4	5	6	7	8	9	10	11	12	13	14	15	16	17	18	19	20
L1	38	57	76	95	114	133	152	171	190	209	228	247	266	285	304	323	342	361	380	399
L2	27	46	65	84	103	122	141	160	179	198	217	236	255	274	293	312	331	350	369	388

n: Stations

3 Port Solenoid Valve Direct Operated Poppet Type **Series VKF300**

Base mounted

Type 40 Manifold Common SUP, Common EXH/Bottom Ported

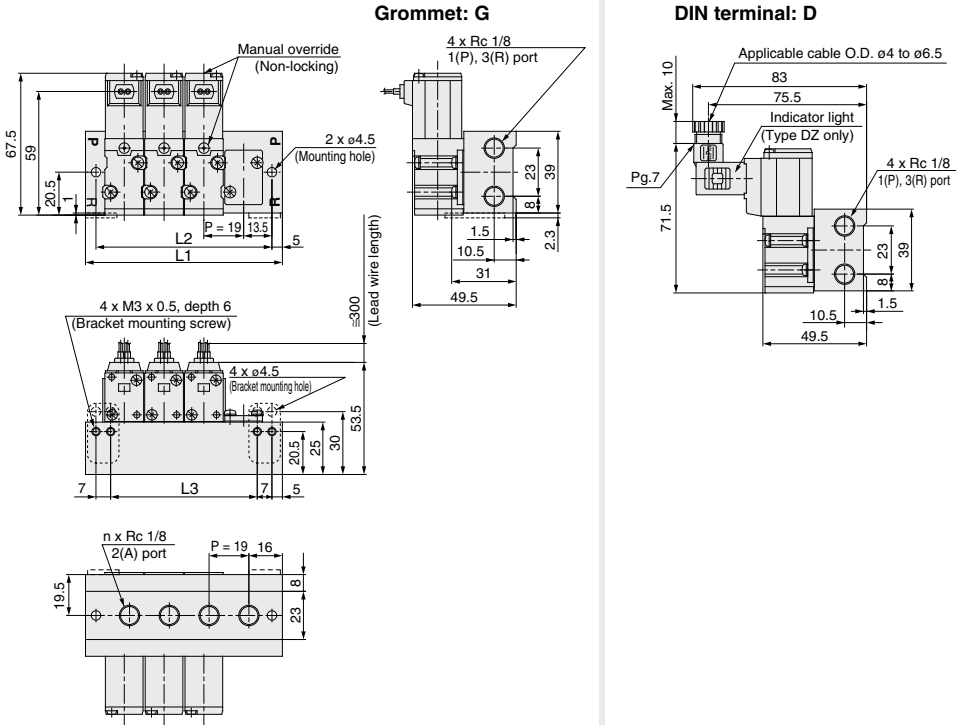

L Dimension

n: Stations

L \ n	1	2	3	4	5	6	7	8	9	10	11	12	13	14	15	16	17	18	19	20
L1	37	56	75	94	113	132	151	170	189	208	227	246	265	284	303	322	341	360	379	398
L2	27	46	65	84	103	122	141	160	179	198	217	236	255	274	293	312	331	350	369	388
L3	13	32	51	70	89	108	127	146	165	184	203	222	241	260	279	298	317	336	355	374

VV061

VV100

V100

S070

VQD

VQD-V

VKF

VK

VT

VS4

VS3

Series VKF300

Dimensions: Manifold

Base mounted

Type 42 Manifold Common SUP, Common EXH/Side Ported

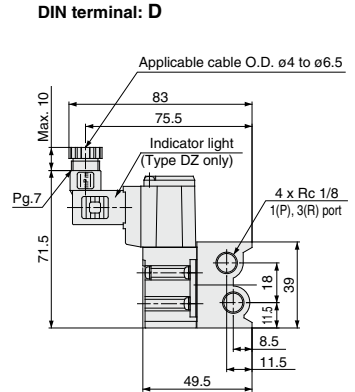
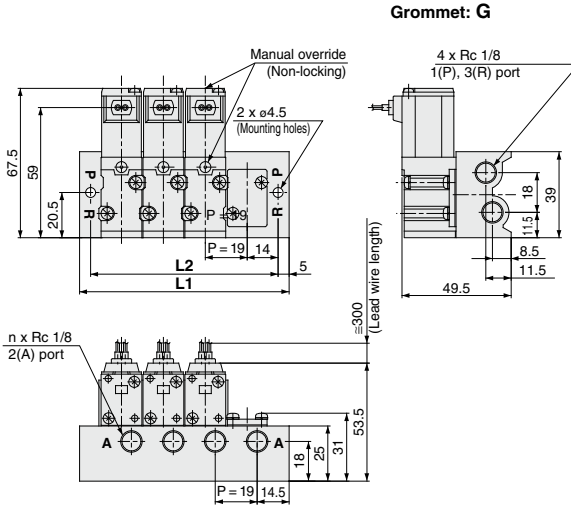

Type S42 Manifold Common SUP, Common EXH/Side Ported: Same direction as solenoid

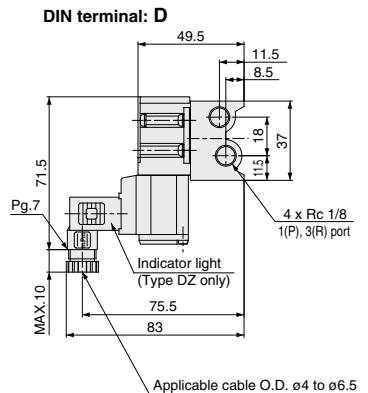
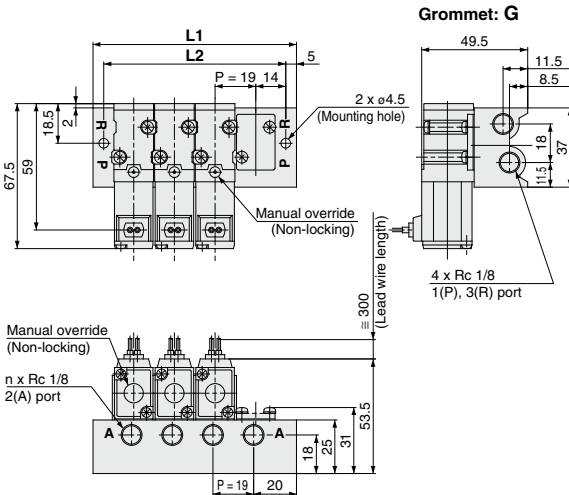

L Dimension

L	n	1	2	3	4	5	6	7	8	9	10	11	12	13	14	15	16	17	18	19	20
L1		38	57	76	95	114	133	152	171	190	209	228	247	266	285	304	323	342	361	380	399
L2		28	47	66	85	104	123	142	161	180	199	218	237	256	275	294	313	332	351	370	389

n: Stations



Series VKF300 Specific Product Precautions 1

Be sure to read before handling. Refer to front matter 53 for Safety Instructions and pages 3 to 8 for 3/4/5 Port Solenoid Valve Precautions.

Manual Override Operation

Warning

Connected actuator is started by manual operation. Use the manual override after confirming that there is no danger.

■ Non-locking push type (Tool required)

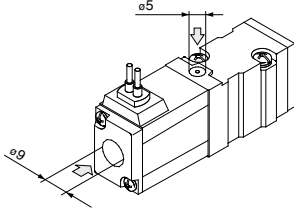

There are manual overrides in 2 directions, on the top and on the side (solenoid side). By pressing either of the manual overrides in the direction of the arrow (R) until it stops (approx. 1 mm), it will turn ON, and it turns OFF when released.

Mounting of Valves

Caution

After confirming the gasket is correctly placed under the valve, securely tighten the bolts with the proper torque shown in the table below.

Proper tightening torque (N·m)
0.6 to 0.8

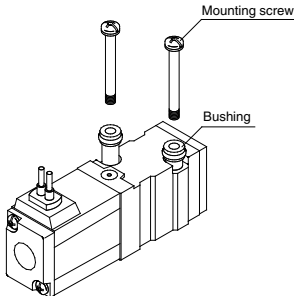

The bushing may be damaged if the tightening torque of 0.8 N·m is exceeded. In the event that damage does occur, be sure to replace the bushing.

SUP Block bushing assembly no.	VKF300-6A-1
--------------------------------	-------------

• 2 sets per unit are required.

Light/Surge Voltage Suppressor

Caution

	Grommet type (G)	DIN terminal type (D)	Symbol
AC	Without indicator light 	No.1 No.2	S
	With indicator light None	No.1 No.2	Z
12 VDC or less	Without indicator light 	No.1 No.2	S
	With indicator light None	No.1 No.2	Z
24 VDC or more	Without indicator light 	No.1 No.2	S
	With indicator light None	No.1 No.2	Z

Precautions on connection of 24 V or more DC

For the grommet type, connect the positive (+) side to the red lead wire and connect the negative (-) side to the black lead wire. For the DIN terminal, connect the positive (+) side to the connector's no.1 terminal and connect the negative (-) side to the no.2 terminal. (See the markings on the terminal block.)

* For 12 V or less DC, positive (+) and negative (-) can be connected in either direction.

● Grommet type

● DIN terminal type

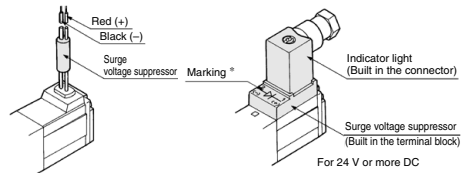

* Marking

For AC and 12 VDC or less 24 VDC or more



Symbol

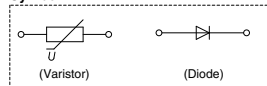

VV061

VV100

V100

S070

VQD

VQD-V

VKF

VK

VT

VS4

VS3



Series VKF300 Specific Product Precautions 2

Be sure to read before handling. Refer to front matter 53 for Safety Instructions and pages 3 to 8 for 3/4/5 Port Solenoid Valve Precautions.

How to Wire DIN Terminal

Warning

• Connection

1. Loosen the set screw and pull out the connector from the terminal block of the solenoid.
2. After removing the holding screw, insert a flat head screwdriver, etc. into the notch on the bottom of the terminal block and pry it up, separating the terminal block and the housing.
3. Loosen the terminal screws (slotted screws) on the terminal block, insert the core of the lead wire into the terminal in accordance with the prescribed connection method, and attach securely with the terminal screws.
4. Tighten the ground nut to secure the wire.

• Change of electrical entry (Orientation)

After separating terminal block and housing, the cord entry direction can be changed by attaching the housing in the desired direction (4 directions in 90 increments).

*In the case of indicator light, avoid damaging the light with lead wire.

• Precautions

The connector should be inserted and pulled out in a straight line without tilting diagonally.

• Applicable cable

O.D.: $\phi 4$ to $\phi 6.5$

(Reference)

0.5 mm² 2 core and 3 core wires equivalent to JIS C 3306

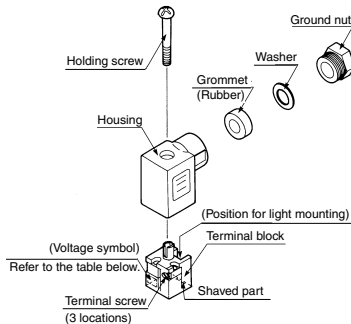

• Connector part no. VK300-82-1

• Part no. for connector with indicator light

Rated voltage	Voltage symbol	Part no.
100 VAC	A1	VK300-82-2-01
200 VAC	A2	VK300-82-2-02
24 VAC	A3	VK300-82-2-07
6 VDC	LW06	VK300-82-4-51
12 VDC	LW2	VK300-82-4-06
24 VDC	LD4	VK300-82-3-05
48 VDC	LD8	VK300-82-3-53

• Circuit with indicator light

AC
Circuit diagram

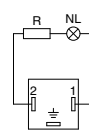

NL: Neon bulb
R: Resistor

12 VDC or less
Circuit diagram

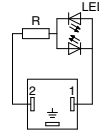

LED: Light emitting diode
R: Resistor

24 VDC or more
Circuit diagram

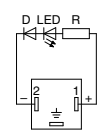

D: Protective diode
LED: Light emitting diode
R: Resistor

How to Calculate the Flow Rate

For obtaining the flow rate, refer to front matters 42 to 45.