

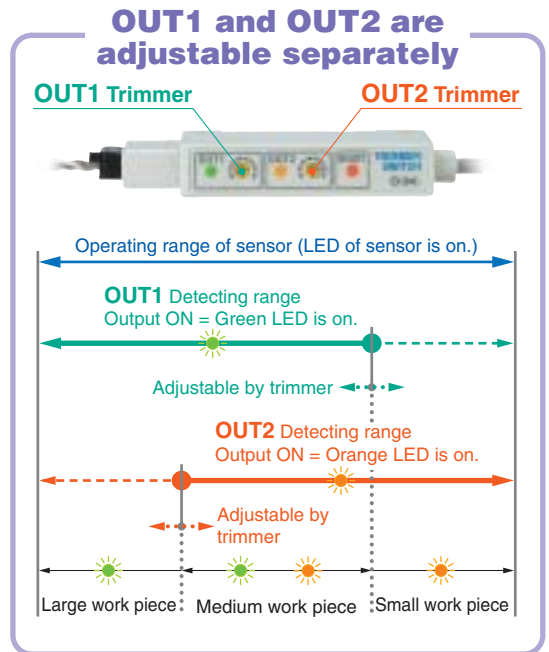

Trimmer Auto Switch

Series **D-□7K/D-R□K**

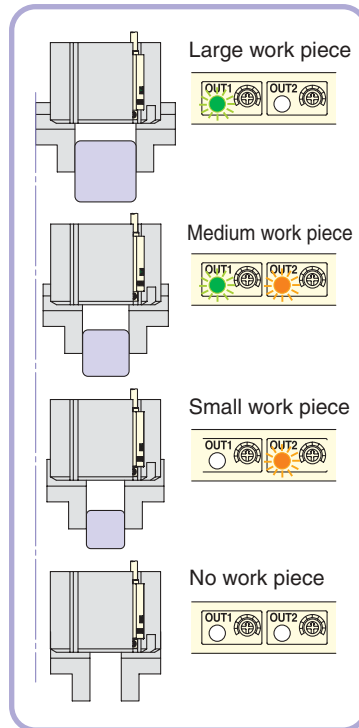
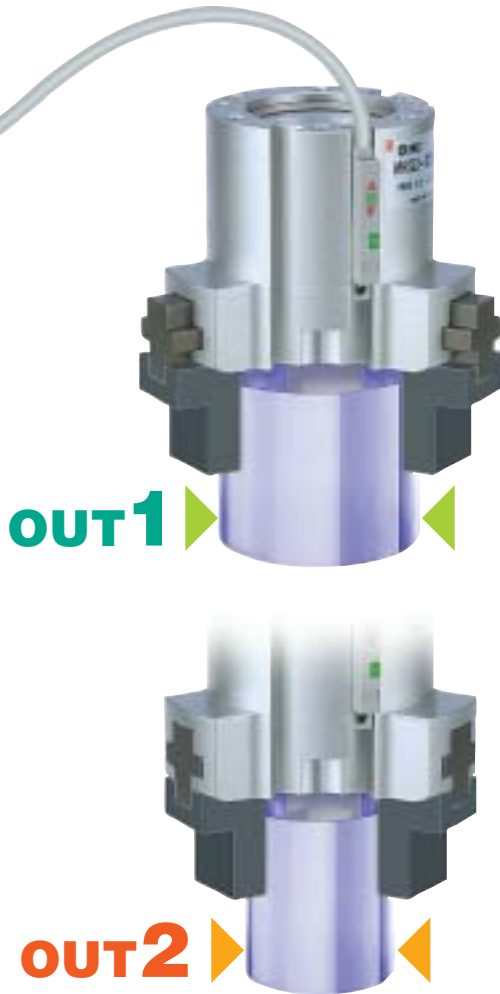

Minimum width to detect
0.5 mm
 With one switch, various sized work pieces can be detected by the difference of more than 0.5mm.
 * From 0.5mm to detectable width dependant on applied actuator.

One auto switch allows work pieces to be distinguished easily.

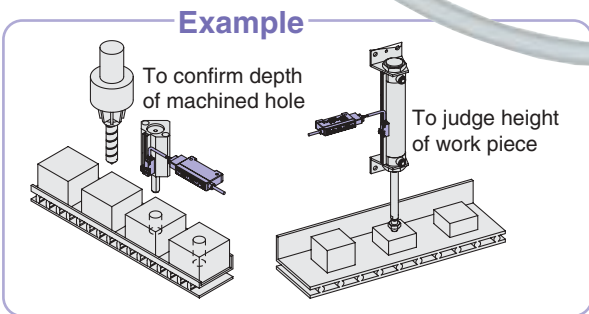

- **Can be mounted on a standard actuator**
 Direct mounting type, rail mounting type
- **Two types of mounting amplifier**
 DIN rail mounting, Direct mounting
- **Joining of connector**
 Sensor and amplifier can be connected without restriction.
- **IP 67 (Sensor)**
 IP40 for amplifier

Trimmer Auto Switch

D-□7K/D-R□K



Sensor unit

Direct mounting type



Rail mounting type



Amplifier unit



Internal Circuit

Sensor unit

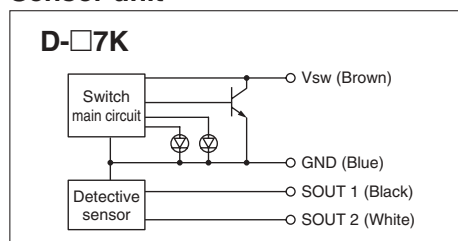

Amplifier unit

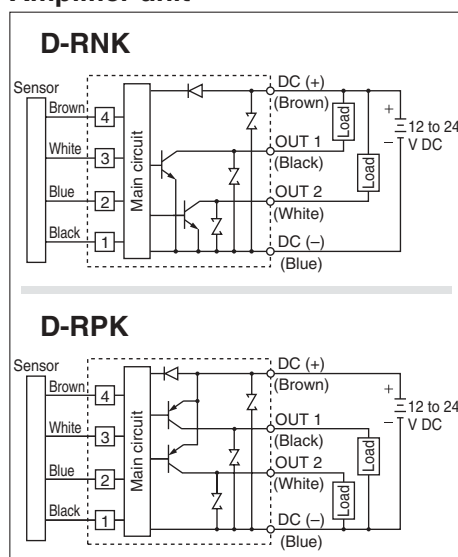

Specifications

Sensor unit

Model	D-F7K	D-Y7K
Mounting	Rail mounting	Direct mounting
Applicable amplifier unit	D-RNK, D-RPK	
Status indication	Operating position: red light is ON. Suitable operating position: green light is ON.	
Electrical entry	Grommet	
Lead wire	Oil proof vinyl heavy insulation cable $\phi 3.5$ 0.14 mm ² 4 cores 3 m With one e-con connector ^{Note)}	
Impact resistance	980 m/s ²	
Insulation resistance	50 M Ω (500 VDC) between lead wire and case	
Withstand voltage	1000 VAC for 1 min. between lead wire and case	
Ambient temperature	-10 to 60 °C	
Enclosure	IP67	
Weight	58 g (with connector)	

Note) The e-con connector is not attached to the lead wire. They will be supplied loose in the same shipment.

Amplifier unit (with sensor unit)

Model	D-RNK	D-RPK
Applicable sensor unit	D-F7K, D-Y7K	
Application	For relay and PLC	
Power supply voltage	12 to 24 VDC	
Current consumption	40 mA or less	
Output specification	NPN open collector Two outputs	PNP open collector Two outputs
Load voltage	28 VDC or less	—
Load current	80 mA or less	
Internal voltage drop	1.5 V or less	
Leakage current	100 μ A or less	
Response time	1 ms or less	
Status indication	READY: Red light emitting diode when the piston position detected. (When the sensor is connected). OUT 1: Green light emitting diode when ON OUT 2: Orange light emitting diode when ON	
Electrical entry	Connection to sensor	e-con connector
	Power supply/output cable	Grommet
Lead wire	Oil proof vinyl heavy insulation cable $\phi 3.5$ 0.14 mm ² 4 cores 3 m	
Impact resistance	98 m/s ²	
Insulation resistance	50 M Ω (500 VDC) between lead wire and case	
Withstand voltage	1000 V AC for 1 min. (between lead wire and case)	
Ambient temperature	-10 to 60 °C	
Enclosure	IP40	
Weight	70 g	

Descriptions

Sensor unit

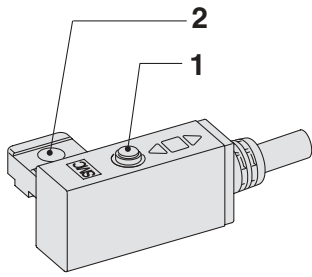

D-F7K

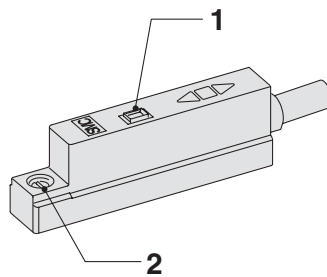

D-Y7K

Sensor unit

1	Indicator light	Red light turns ON when sensor detects the magnet field. Green light is ON during the suitable position to detect the magnetic field (including most sensitive position).
2	ø3.2 mounting hole M2.5 x 4L slotted set screw	Fixes the sensor to the actuator.

Amplifier unit

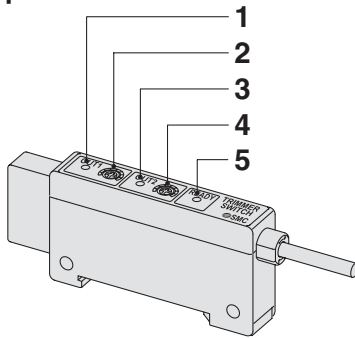

D-R□K

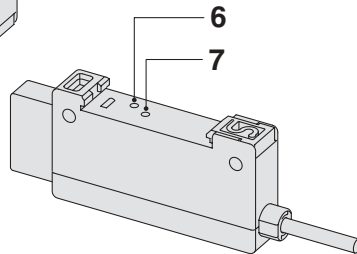

Amplifier unit

1	Output (OUT1) indication: green	Lights up when OUT1 outputs.
2	OUT1 adjusting trimmer	Adjusts the output range of OUT1 when sensor unit detects the magnetic field.
3	Output (OUT2) indication: orange	Lights up when OUT2 outputs.
4	OUT2 adjusting trimmer	Adjusts the output range of OUT2 when sensor unit detects the magnetic field.
5	Confirmation of detection at sensor unit (READY): red	Lights up when sensor unit is detecting the magnetic field. While its lighting, output ranges of OUT1 and OUT2 are adjustable.
6	Offset adjusting trimmer (ADJ)	Adjusts the sensor unit at the time of connection. Once adjusts, no need to re-adjust as long as the sensor unit is not replaced. Adjustment must be undertaken while the sensor unit is removed from the actuator. Refer to the operation manual for details.
7	Confirmation of offset adjustment (OFFSET): red	Lights up when offset adjustment is completed.

Refer to the operation manual for how to adjust/set.

Applicable actuator and operation range (angle)

The operating ranges are provided as guidelines including the hysteresis and are not guaranteed value. Consult SMC for alternative actuators than those shown below.

Sensor unit D-Y7K

Air gripper

Model	Bore size (mm)										
	10	12	16	20	25	32	40	50	63	80	100
Parallel gripper MHZ2	4	—	5	7	7	8	8.5	—	—	—	—
Wide opening MHL2	6.8	—	8	8.5	10.5	11	12.5	—	—	—	—
Parallel gripper MHS2 (2 finger)	—	—	—	—	—	6.5	7	7.5	8.5	—	—
Parallel gripper MHS3 (3 finger)	—	—	—	—	—	6.5	7	7.5	8	—	—
Parallel gripper MHS4 (4 finger)	—	—	—	—	—	6.5	7	7.5	8.5	—	—
Angular gripper MHC2	30° to -10°	—	30° to -10°	30° to -10°	22.5° to -10°	—	—	—	—	—	—
180° opening/closing MHW2	—	—	—	88° to -5°	54° to -6°	58° to -5°	41° to -5°	30° to -4°	—	—	—

Air cylinder

Model	10	12	16	20	25	32	40	50	63	80	100
Compact guide cylinder MGP	—	3.5	5	4.5	4.5	5.5	5.5	5.5	5.5	5.5	6
Air cylinder CA2	—	—	—	—	—	—	4	4	6	6	6

Sensor unit D-F7K

Air cylinder

Model	Bore size (mm)												
	12	16	20	25	32	40	50	63	80	100	125	140	160
Compact cylinder CQ2	4.5	5.5	5.5	5	5.5	5.5	5.5	6	5.5	6	7.5	7.5	7.5
Air cylinder CM2	—	—	3.5	3.5	3.5	3.5	—	—	—	—	—	—	—

D-□7K/D-R□K

Dimensions

Sensor unit

D-F7K

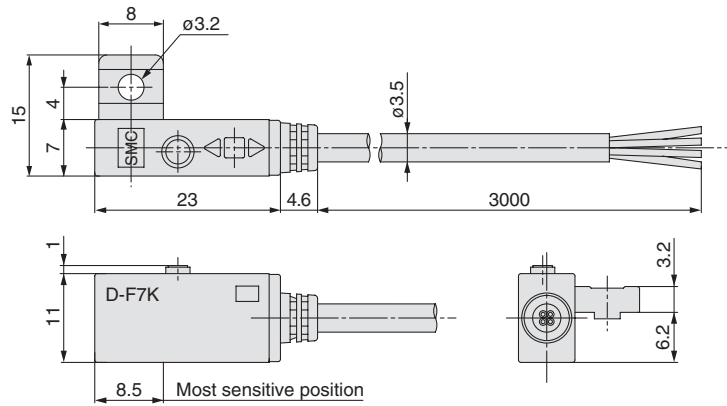

D-Y7K

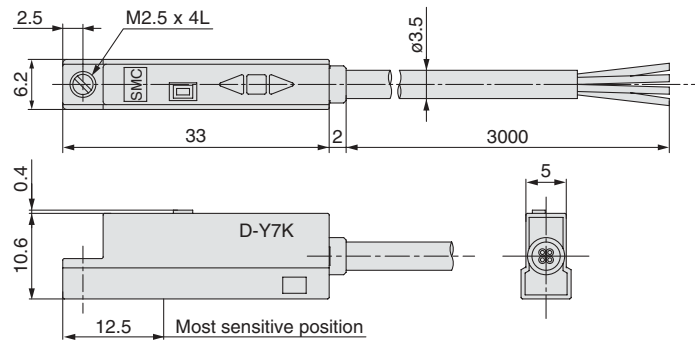

Amplifier unit

D-R□K

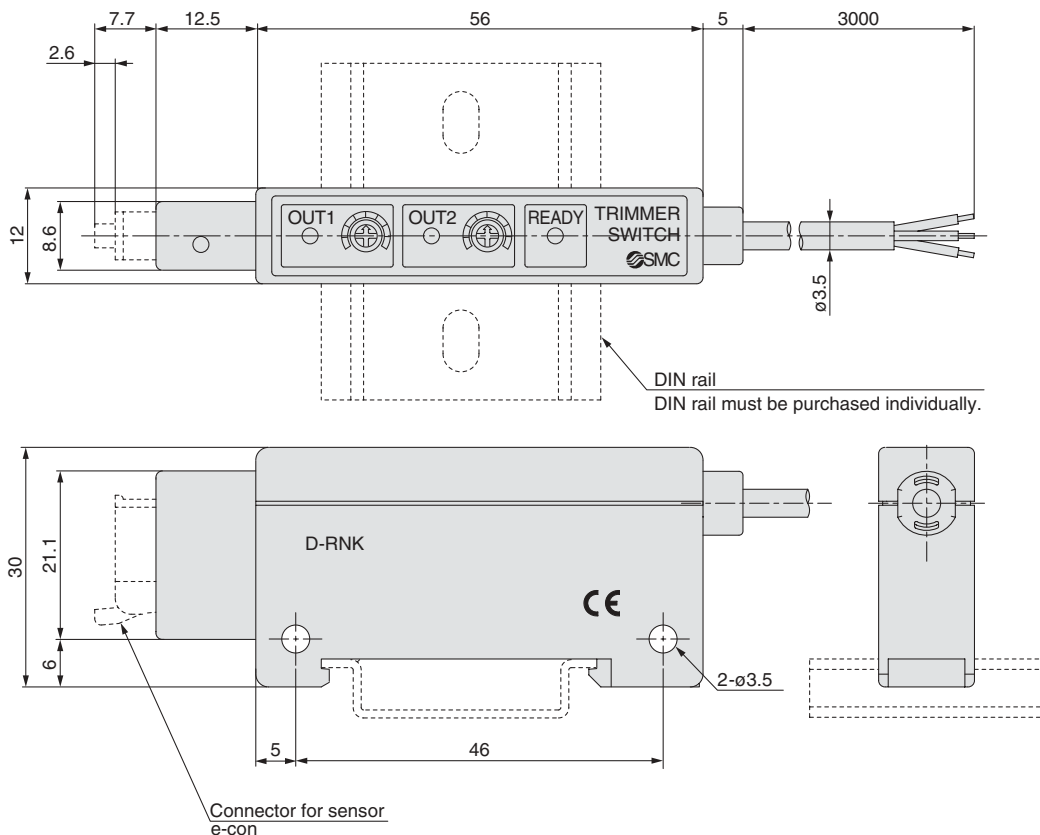





Trimmer Auto Switch

Safety Instructions

These safety instructions are intended to prevent a hazardous situation and/or equipment damage. These instructions indicate the level of potential hazard by a label of "**Caution**", "**Warning**" or "**Danger**". To ensure safety, be sure to observe ISO 4414 Note 1), JIS B 8370 Note 2) and other safety practices.

 **Caution** : Operator error could result in injury or equipment damage.

 **Warning** : Operator error could result in serious injury or loss of life.

 **Danger** : In extreme conditions, there is a possible result of serious injury or loss of life.

Note 1) ISO 4414: Pneumatic fluid power – General rules relating to systems

Note 2) JIS B 8370: Pneumatic system axiom

Warning

1. The compatibility of pneumatic equipment is the responsibility of the person who designs the pneumatic system or decides its specifications.

Since the products specified here are used in various operating conditions, their compatibility with the specific pneumatic system must be based on specifications or after analysis and/or tests to meet your specific requirements. The expected performance and safety assurance will be the responsibility of the person who has determined the compatibility of the system. This person should continuously review the suitability of all items specified, referring to the latest catalog information with a view to giving due consideration to any possibility of equipment failure when configuring a system.

2. Only trained personnel should operate pneumatically operated machinery and equipment.

Compressed air can be dangerous if handled incorrectly. Assembly, handling or maintenance of pneumatic systems should be performed by trained and experienced operators.

3. Do not service machinery/equipment or attempt to remove components until safety is confirmed.

1. Inspection and maintenance of machinery/equipment should only be performed after confirmation of safe locked-out control positions.
2. When equipment is to be removed, confirm the safety process as mentioned above. Cut the supply pressure for this equipment and exhaust all residual compressed air in the system.
3. Before machinery/equipment is restarted, take measures to prevent shooting-out of cylinder piston rod, etc. (Bleed air into the system gradually to create back pressure.)

4. Contact SMC if the product is to be used in any of the following conditions:

1. Conditions and environments beyond the given specifications, or if product is used outdoors.
2. Installation on equipment in conjunction with atomic energy, railway, air navigation, vehicles, medical equipment, food and beverages, recreation equipment, emergency stop circuits, press applications, or safety equipment.
3. An application which has the possibility of having negative effects on people, property, and therefore requires special safety analysis.



Trimmer Auto Switch Precautions 1

Be sure to read before handling

Design & Selection

Warning

1. Confirm the specifications.

Read the specifications carefully and use this product appropriately. The product may be damaged or malfunction if it is used outside the range of specifications of current load, voltage, temperature or impact.

2. Take precautions when multiple cylinders are used close together.

When multiple auto switch cylinders are used in close proximity, magnetic field interference may cause the switches to malfunction. Maintain a minimum cylinder separation of 40mm. (When the allowable separation is indicated for each cylinder series, use the specified value.)

3. Keep the wiring as short as possible.

Use a wire 3m or shorter between the sensor and amplifier. Although wire length of power supply/output cable should not affect switch function, use a wire 100m or shorter.

4. Take precautions for the internal voltage drop of the switch.

5. Pay attention to leakage current.

Although a varistor for surge protection is connected at the output side of a trimmer auto switch, damage may still occur if the surge is applied repeatedly. When a load, such as a relay, solenoid, which generates surge is directly driven, use a type of switch with a built-in surge absorbing element.

6. Cautions for use in an interlock circuit.

When an auto switch is used for an interlock signal requiring high reliability, devise a double interlock system to avoid trouble by providing a mechanical protection function, or by also using another switch (sensor) together with the trimmer auto switch. Also perform periodic maintenance and confirm proper operation.

7. Ensure sufficient clearance for maintenance activities.

When designing an application, be sure to allow sufficient clearance for maintenance and inspections.

Mounting & Adjustment

Warning

1. Do not drop or bump.

Do not drop, bump or apply excessive impacts (980m/s² or more for sensor unit and 98m/s² or more for amplifier unit) while handling.

Although the body of the switch may not be damaged, the inside of the switch could be damaged and cause a malfunction.

2. Do not carry a cylinder by the auto switch lead wires.

Never carry a cylinder by its lead wires. This may not only break the lead wires, but it may cause internal elements of the switch to be damaged by the stress.

3. Mount switches using the proper tightening torque.

When a switch is tightened beyond the range of tightening torque, the mounting screws, mounting bracket or switch may be damaged. On the other hand, tightening below the range of tightening torque may allow the switch to slip out of position.

Wiring

Warning

1. Avoid repeatedly bending or stretching lead wires.

Broken lead wires will result from applying bending stress or stretching forces to the lead wires.

2. Be sure to connect the connector for sensor to the amplifier before power is applied.

3. Confirm proper insulation of wiring.

Be certain that there is no faulty wiring insulation (contact with other circuits, ground fault, improper insulation between terminals, etc.). Damage may occur due to excess current flow into a switch.

4. Do not wire with power lines or high voltage lines.

Wire separately from power lines or high voltage lines, avoiding parallel wiring or wiring in the same conduit with these lines. Control circuits, including auto switches, may malfunction due to noise from these other lines.

5. Do not allow short circuit of loads.

Output is automatically stopped when the protection circuit is working, as the output unit registers any excess current flow, if loads are short circuited. Should this occur, shut off the power supply, remove the cause of this excess current flow and switch on the power again. Take special care to avoid reverse wiring between the power supply line (brown) and the output line (black, white).

6. Avoid incorrect wiring.

If the connections are reversed (power supply line + and power supply line -), the switch will be protected by a protection circuit. However, if the power supply line (-) is connected to the black, white wire, the switch will be damaged.



Trimmer Auto Switch Precautions 2

Be sure to read before handling

Operating Environment

Warning

1. Never use in an atmosphere with explosive gases.

The structure of trimmer auto switches is not designed to prevent explosion. Never use in an atmosphere with an explosive gas since this may cause a serious explosion.

2. Do not use in an area where a magnetic field is generated.

Trimmer auto switches will malfunction or magnets inside cylinders will become demagnetized.

3. Do not use in an environment where the trimmer auto switch will be continually exposed to water.

Although the sensor units of trimmer auto switches satisfy the IEC standard IP67 structure (JIS C0920: watertight construction), do not use trimmer auto switches in applications where continually exposed to water splash or spray. Poor insulation or swelling of the potting resin inside switches may cause malfunction.
(Amplifier part D-RNK and RPK: IP40)

4. Do not use in an environment with oil or chemicals.

Consult SMC if auto switches will be used in an environment with coolant, cleaning solvent, various oils or chemicals. If auto switches are used under these conditions for even a short time, they may be adversely affected by improper insulation, malfunction due to swelling of the potting resin, or hardening of the lead wires.

5. Do not use in an environment with temperature cycles.

Consult SMC if switches are used where there are temperature cycles other than normal temperature changes, as they may be adversely affected.

6. Do not use in an area where surges are generated.

When there are units (solenoid type lifter, high frequency induction furnace, motor, etc.) which generate a large amount of surge in the area around cylinders with trimmer auto switches, this may cause deterioration or damage to the circuit element inside the switch. Take measures against sources of surge generation and take caution to crossed lines.

7. Avoid accumulation of iron powder or close contact with magnetic substances.

When a large amount of ferrous powder such as machining chips or spatter is accumulated, or a magnetic substance is brought into close proximity with an auto switch cylinder, it may cause the auto switch to malfunction due to a loss of the magnetic force inside the cylinder.

8. Take measures against freezing when operating at 5°C or less.

Maintenance

Warning

1. Perform the following maintenance periodically in order to prevent possible danger due to unexpected trimmer auto switch malfunction.

- 1) Secure and tighten switch mounting screws.
If screws become loose or the mounting position is dislocated, retighten them after readjusting the mounting position.
- 2) Confirm that there is no damage to lead wires.
To prevent faulty insulation, replace switches or repair lead wires, etc., if damage is discovered.

Other

Warning

1. Consult SMC concerning water resistance, elasticity of lead wires, and usage at welding sites, etc.



Trimmer Auto Switch Precautions 3

Be sure to read before handling

Wiring

⚠ Caution

1. Connection and removal of connector

- Hold the lever and connector body with two fingers and insert the connector straight into the pin until it is locked with a click sound.
- To remove the connector, pull it out straight while pressing the lever with one finger.

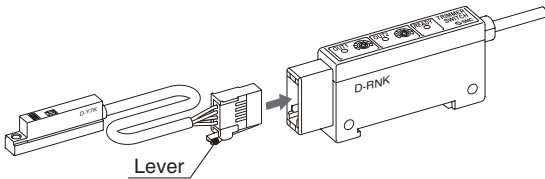

2. Connection of sensor connector

- Cut the sensor cable as illustrated to the right.
- Referring to the table below, insert each lead wire of the cable at the position marked with a number corresponding to the color of the lead wire.

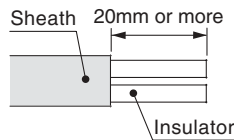

Connector no.	Wire core color
1	Black (SOUT1)
2	Blue (GND)
3	White (SOUT2)
4	Brown (Vsw)

- Confirm that the numbers on the connector match the colors of the wires and that the wires are inserted to the bottom. Press part A by hand for temporary fixing.
- Press in the central part of Part A vertically with a tool such as pliers.
- A sensor connector cannot be taken apart for reuse once it is crimped. If the wire arrangement is incorrect or if the wire insertion fails, use a new sensor connector.

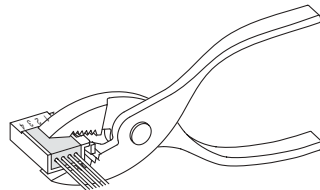
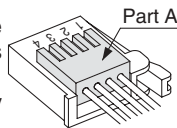

Manufacturer	Part no.
Tyco Electronics AMP	1473562-4

- For detailed information about e-con connectors, please consult the manufacturers of the respective connectors.

Mounting of Amplifier Unit

⚠ Caution

- Use mounting screws (M3 x 16L) or DIN rail (35mm width).
- Adjust offset before mounting of the amplifier unit.

1. Mounting with screws

- Tighten two M3 x 16L mounting screws at a tightening torque of 0.5 to 0.7 N·m.
- Mounting surface should be flat and even. A bumpy or uneven mounting surface can result in damage to the case.

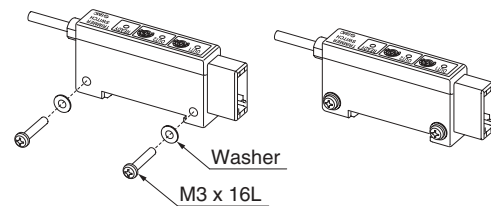

2. Mounting and removal to DIN rail

Mounting

- Hook the claw 1 of the amplifier body to the upper part of DIN rail, press down and push horizontally until the claw 2 is locked with a click sound.

Removal

- To remove from the DIN rail, push the amplifier body upward and then pull it horizontally to release from the claw 1 side.

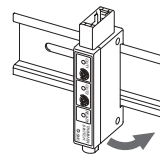
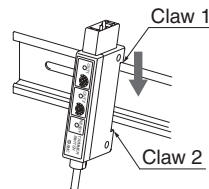

- In the case of mounting to the DIN rail, SMC recommends the following end plates: as detailed in the table on the right. Consult each manufacturer for the handling and details of end plate.

Manufacturer	Part no.
OMRON Corporation	PFP-M
IDEC IZUMI Corporation	BNL6

3. Refer to each applicable actuator's catalog for the mounting of sensor unit.

SMC CORPORATION

1-16-4 Shimbashi, Minato-ku, Tokyo 105-8659, JAPAN
 Tel: 03-3502-2740 Fax: 03-3508-2480
 URL <http://www.smcworld.com>
 © 2003 SMC CORPORATION All Rights Reserved

1st printing November, 2003 D-YGA P-120 (YG)

This catalog is printed on recycled paper with concern for the global environment.

All specifications in this catalog are subject to change without notice.

Printed in Japan.