

4/5 Port Solenoid Valve

Power Consumption
0.1 W
 With Power Saving Circuit

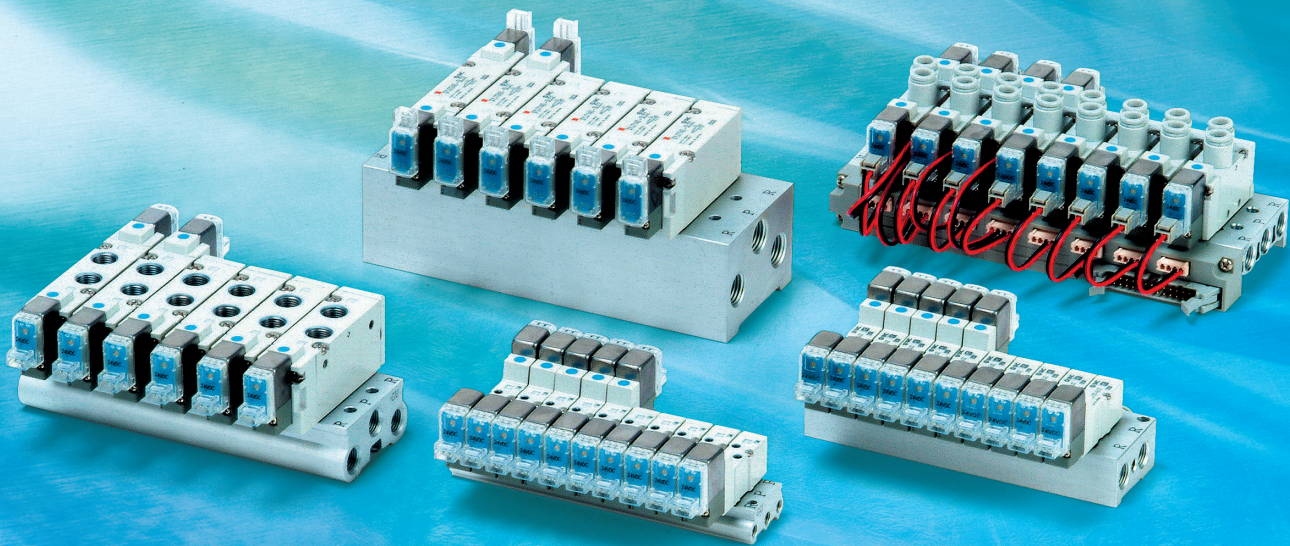

Series SYJ3000/5000/7000

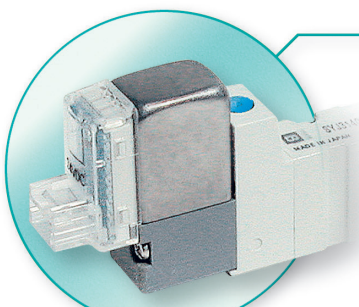

Cover (stainless steel)

● Improved pilot valve



Pilot valve cover is stronger using stainless steel.
 Mounting thread is also reinforced from size M1.7 to M2.

● Flow Characteristics

Series	Flow characteristics			
	C [(dm ³ /s·bar)]	b	Cv	Q[l/mibn(ANR)]
SYJ3000	0.46	0.36	0.12	122
SYJ5000	0.83	0.32	0.21	214
SYJ7000	2.9	0.35	0.74	762

Rubber Seal 4/5 Port Solenoid Valve Series SYJ3000/5000/7000

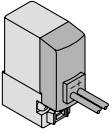
Variations

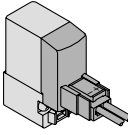
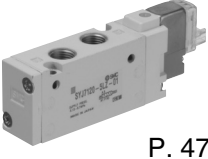
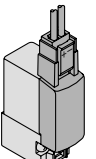
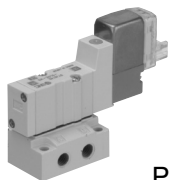
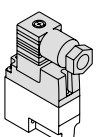
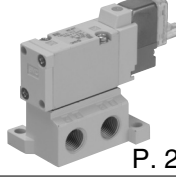
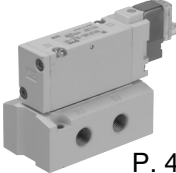
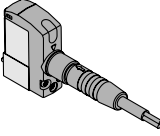
	Series	Sonic conductance: C [dm ³ /(s·bar)]	Type of actuation	Voltage	Electrical entry	Option	Manual override		
						With light/surge voltage suppressor			
Body ported	SYJ3000  P. 1	Effective area 0.9 mm ² { 4/2 → 5/3 } { (A/B → EA/EB) }		For DC ■ 24 VDC 12 VDC 6 VDC 5 VDC 3 VDC	Grommet 	For DC ■ With surge voltage suppressor			
	SYJ5000  P. 23	0.47 { 4/2 → 5/3 } { (A/B → EA/EB) }						L plug connector 	■ With light/ surge voltage suppressor
	SYJ7000  P. 47	2.4 { 4/2 → 5/3 } { (A/B → EA/EB) }						2 Position ● Single ● Double M plug connector 	
Base mounted	SYJ3000  P. 1	0.46 { 4/2 → 5/3 } { (A/B → EA/EB) }	3 Position ● Closed center ● Exhaust center ● Pressure center	For AC ■ 100 VAC ^{50/60} Hz 110 VAC ^{50/60} Hz 200 VAC ^{50/60} Hz 220 VAC ^{50/60} Hz	DIN terminal  (SYJ5000, 7000 only)	For AC ^{Note)} ■ With light/surge voltage suppressor	■ Non-locking push type ■ Push-turn locking slotted type ■ Push-turn locking lever type		
	SYJ5000  P. 23	0.83 { 4/2 → 5/3 } { (A/B → EA/EB) }							
	SYJ7000  P. 47	2.9 { 4/2 → 5/3 } { (A/B → EA/EB) }	M8 connector 						

 Note) All AC voltage models have built-in surge voltage suppressor.

Series SYJ3000/5000/7000

Manifold Variations

Valve series	A, B port location	A, B port size									Manifold option			Flat ribbon cable manifold			
		M3	M5	1/8	With one-touch fitting						Individual SUP spacer assembly	Individual EXH spacer assembly	Interface regulator				
					Applicable tubing O.D.												
					ø4	ø6	ø8	N3	N7	N9							
Body ported	SYJ3000	Top	●	—	—	—	—	—	—	—	—	—	—	—	—	●	
	SYJ5000	Top	—	●	—	●	●	—	●	●	—	●	●	—	—	●	
	SYJ7000	Top	—	—	●	—	●	●	—	●	●	—	—	—	—	●	
Base mounted	SYJ3000	Side	●	●	—	●	—	—	●	—	—	—	—	—	—	●	
		Bottom	—	—	—	—	—	—	—	—	—	—	—	—	—	—	
	SYJ5000	Side	—	●	—	●	●	—	●	●	—	—	—	●	—	—	●
		Bottom	—	●	—	—	—	●	—	—	—	—	—	●	—	—	—
	SYJ7000	Side	—	—	●	—	●	—	—	●	—	—	—	—	—	—	—
		Bottom	—	—	●	—	—	—	—	—	—	—	—	—	—	—	—

Body ported

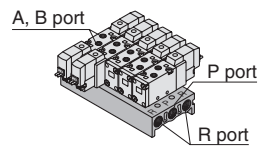

Base mounted

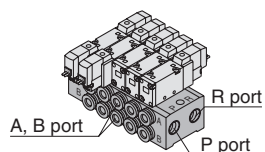
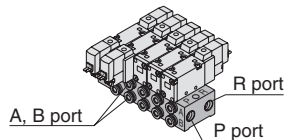
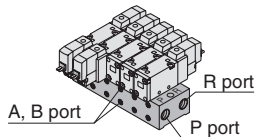
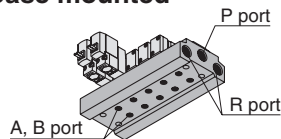

Individual SUP spacer assembly

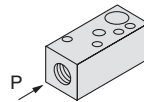

Individual EXH spacer assembly

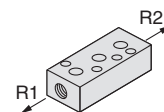

Interface regulator

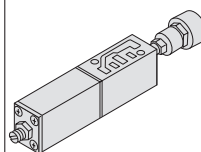

Type 21P

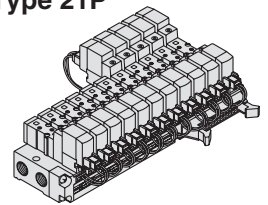

Type 32P

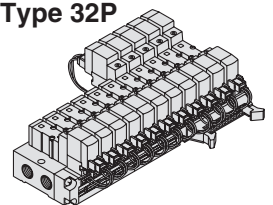

Mixed mounting of 3 port valves and 4, 5 port valves

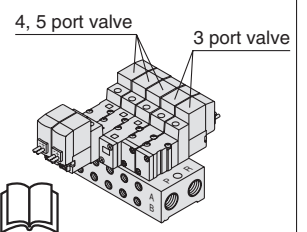

For detailed specifications about SYJ3000, refer to page 14. For SYJ5000, refer to page 38, and for SYJ7000, refer to page 61.

Rubber Seal 4/5 Port Solenoid Valve



Series SYJ3000



For details about certified products conforming to international standards, visit us at www.smcworld.com.

Specifications

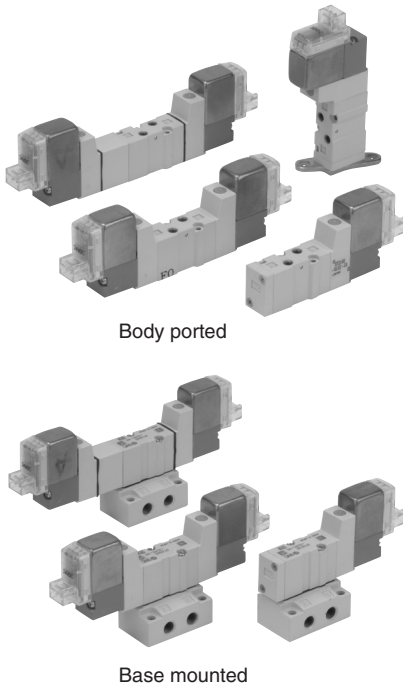

Body ported

Base mounted

Fluid		Air
Operating pressure range (MPa)	2 position single	0.15 to 0.7
	2 position double	0.1 to 0.7
	3 position	0.2 to 0.7
Ambient and fluid temperature (°C)		-10 to 50 (No freezing. Refer to back page 3.)
Response time (ms) (at 0.5 MPa) ^{Note 1)}	2 position single, double	15 or less
	3 position	30 or less
Max. operating frequency (Hz)	2 position single, double	10
	3 position	3
Manual override (Manual operation)	Non-locking push type, Push-turn locking slotted type, Push-turn locking lever type	
Pilot exhaust method	Individual exhaust for the pilot valve, Common exhaust for the pilot and main valve	
Lubrication	Not required	
Mounting orientation	Unrestricted	
Shock/Vibration resistance (m/s²) ^{Note 2)}	150/30	
Enclosure	Dust proof (* M8 connector conforms to IP65.)	



* Based on IEC60529

Note 1) Based on dynamic performance test, JIS B 8375-1981. (Coil temperature: 20°C, at rated voltage, without surge voltage suppressor)

Note 2) Impact resistance: No malfunction occurred when it is tested in the axial direction and at the right angles to the main valve and armature in both energised and de-energised states every once for each condition. (Value in the initial state)

Vibration resistance: No malfunction occurred in one sweep test between 45 and 2000 Hz. Test was performed to axis and right angle directions of the main valve when pilot signal is ON and OFF. (Value in the initial state)

Solenoid Specifications

JIS Symbol 5 port

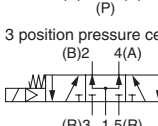
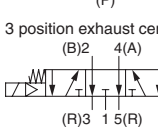
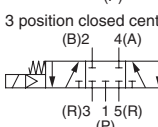
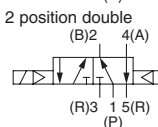
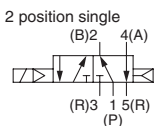

4 port (manifold)

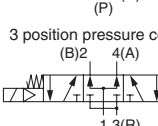
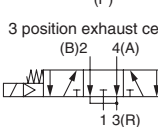
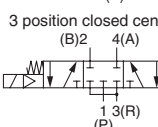
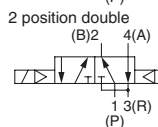
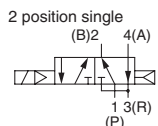

Electrical entry	Gromet (G), (H), L plug connector (L), M plug connector (M), M8 connector (W)	
Coil rated voltage (V)	DC	24, 12, 6, 5, 3
Allowable voltage fluctuation	10% of rated voltage *	
Power consumption (W)	DC	Standard 0.35 (With light: 0.4)
		With power saving circuit 0.1 (With light only)
Surge voltage suppressor	Diode (Non-polarity type: Valistor)	
Indicator light	LED	



* S, Z and T type (with power saving circuit) should be used within the following allowable voltage fluctuation range due to a voltage drop caused by the internal circuit. S and Z type: 24 VDC: -7% to +10%, 12 VDC: -4% to +10%
T type: 24 VDC: -8% to +10%, 12 VDC: -6% to +10%

Bracket Mounting

① Insert the lower hook of the mounting bracket into the groove on the bottom of the valve as shown.

② Press the valve and mounting bracket together until the upper hook of the bracket snaps into place in the groove on top of the valve.

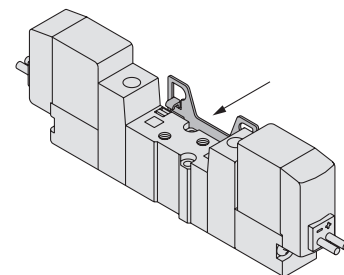
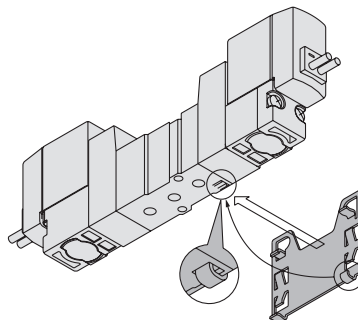

Made to Order
(For details, refer to page 78.)

Flow Characteristics/Weight

Valve model		Type of actuation		Port size		Weight (g) ^{Note 3, 4)}			Effective area (mm ²)	Flow characteristics ^{Note 2)}													
				1, 5, 3 (P, EA, EB)	4, 2 (A, B)	Grommet	L/M plug connector	M8 connector		1R4/2 (PRA/B)				4/2R5/3 (A/BREA/EB)									
				C [dm ³ /(s·bar)]	b	Cv	Q _l [l/min/(ANR)]*	C [dm ³ /(s·bar)]		b	Cv	Q _l [l/min/(ANR)]*											
5 port Base mounted (with sub-plate)	SYJ314□	2 position	Single	M5	M5	62 (36)	63 (37)	67 (41)	—	0.46	0.36	0.12	122	0.46	0.35	0.12	121						
	SYJ324□		Double			79 (53)	81 (55)	89 (63)															
	SYJ334□	3 position	Closed center			—	0.47	0.33										0.12	122	0.47	0.31	0.12	120
	SYJ344□		Exhaust center																				
SYJ354□	Pressure center	—	0.58 [0.32]	0.42 [0.33]	0.16 [0.080]				160 [83]	0.46	0.32	0.11	118										
SYJ312□	2 position													Single	M3	M3	36						
SYJ322□						Double	53	55						63									
SYJ332□	3 position					Closed center	—	0.56						0.58			0.66	—					
SYJ342□		Exhaust center	56	58	66																		
SYJ352□	Pressure center	—	—																				
SYJ313□	2 position			Single	1/8	M5			36	37	41	—											
SYJ323□				Double			53	55	63														
SYJ333□	3 position			Closed center			—	0.56	0.58	0.66	—												
SYJ343□		Exhaust center	56	58									66										
SYJ353□	Pressure center	—	—																				



Note 1) Dedicated for manifold base. For details, refer to page 11.

Note 2) [] denotes the normal position. Exhaust center: 4/2 R 5/3, Pressure center: 1 R 4/2

Note 3) (): Without sub-plate.

* These values have been calculated according to ISO6358 and represent the flow rate measured in standard conditions at an upstream of 0.6MPa (relative pressure) and a differential pressure of 0.1MPa.

Cylinder Speed Chart

Use as a guide for selection.
Please confirm the actual conditions with SMC Sizing Program.

Body Ported

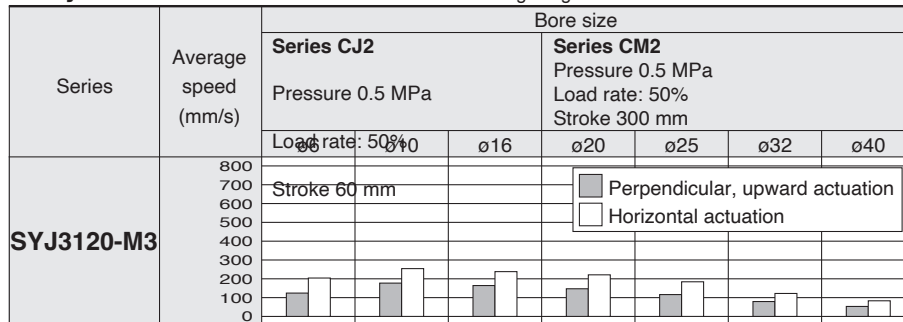

Base Mounted

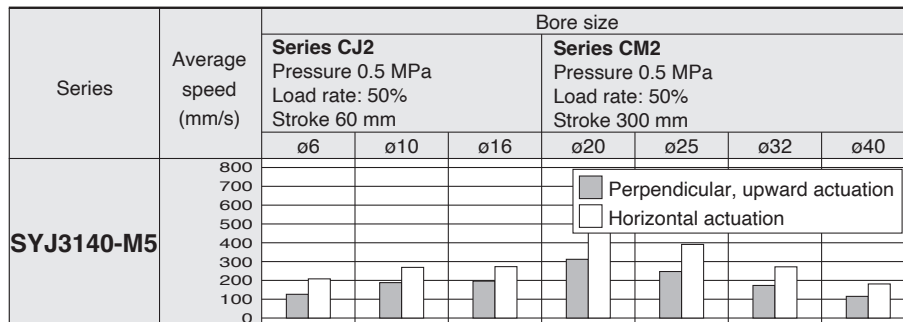

* Cylinder is in extending. Speed controller is meter-out, which is directly connected with cylinder and its needle is fully opened.

* Average speed of cylinder is obtained by dividing the full stroke time by the stroke.

* Load factor: ((Load weight x 9.8) / Theoretical force) x 100%

Conditions

Body ported		Series CJ2	Series CM2
SYJ3120-M3	Tubing bore x Length	ø4 x 1 m	
	Speed controller	AS1301F-04	
	Silencer	AN120-M3	

Base mounted		Series CJ2	Series CM2
SYJ3140-M5	Tubing bore x Length	ø6 x 1 m	
	Speed controller	AS2001F-06	AS2301F-06
	Silencer	AN120-M5	

How to Order

Type of actuation

1	2 position single solenoid
2	2 position double solenoid
3	3 position closed center
4	3 position exhaust center
5	3 position pressure center

Light/surge voltage suppressor

-	Without light/surge voltage suppressor
S	With surge voltage suppressor
Z	With light/surge voltage suppressor
R	With surge voltage suppressor (Non-polar type)
U	With light/surge voltage suppressor (Non-polar type)



* Power saving circuit is only available in the "Z" type.

Bracket

-: Without bracket
F: With bracket

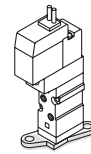

Single

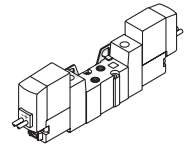

Double

* Brackets cannot be retrofitted.



Note • The double solenoid mounting bracket is supplied unattached.
• To order the double solenoid bracket for use with a single solenoid valve, order the single solenoid valve without a bracket and order the bracket (VJ3000-13-1) separately.
(Example) SYJ3120-5M-M3 VJ3000-13-1

5 port

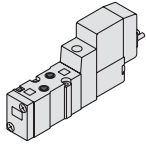

(Type 20 Manifold)

Rated voltage

DC	
5	24 VDC
6	12 VDC
V	6 VDC
S	5 VDC
R	3 VDC

Body ported

SYJ3 1 2 0 □ 5 M □ □ - M3 - □ - Q

Base mounted (4 port)

SYJ3 2 3 0 □ 5 M □ □ - Q (Manifold use only)

Base mounted (5 port)

SYJ3 2 4 0 □ 5 M □ □ - □ - Q

4 port

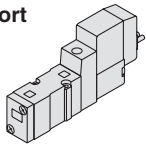

(For manifold type 31, S31, 32, S32)

5 port

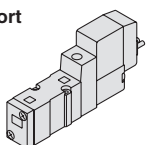

(For sub-plate, manifold type 41, S41, 46, S46)

Coil specifications

-	Standard
T	With power saving circuit (24, 12 VDC only)



* Power saving circuit is not available in the case of W□ type.

Body option

0: Pilot valve individual exhaust for the pilot valve

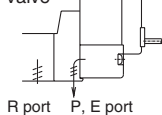

3: Common exhaust type for main and pilot valve

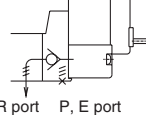

Manual override

-: Non-locking push type

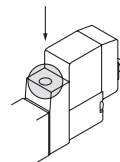

D: Push-turn locking slotted type

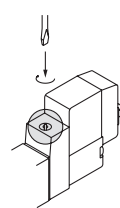

E: Push-turn locking lever type

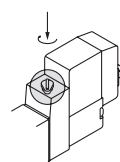

Port size

-: Without sub-plate

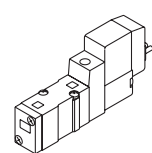

(With gasket and screws)

M5: With M5 port sub-plate

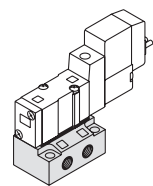

Electrical entry

24, 12, 6, 5, 3 VDC				24, 12, 6, 5, 3 VDC	
Grommet	L plug connector	M plug connector		M8 connector *	
G: Lead wire length 300 mm	L: With lead wire (Length 300 mm)	M: With lead wire (Length 300 mm)	MN: Without lead wire	WO: Without connector cable	
H: Lead wire length 600 mm	LN: Without lead wire	LO: Without connector	MO: Without connector	W□: With connector cable (Note 1)	



* LN, MN type: with 2 sockets.
* For connector cable of M8 connector, refer to back page 10.
* Connector M8 type "WA" conforming to IEC 60947-5-2 standard, is also available. For details, see page 80.

Note 1) Enter the cable length symbols in □. Please be sure to fill in the blank referring to back page 10.



Note) When placing an order for body ported solenoid valve as a single unit, mounting bolt for manifold and gasket are not attached. Order them separately, if necessary. (For details, refer to page 15.)

Construction

2 position single

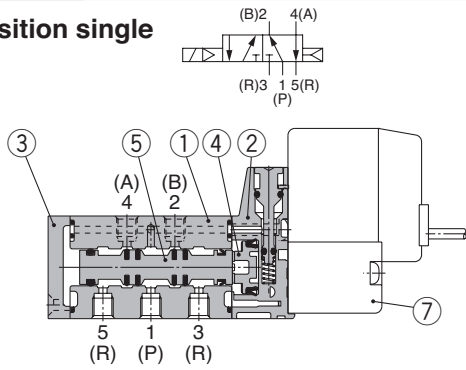

2 position double

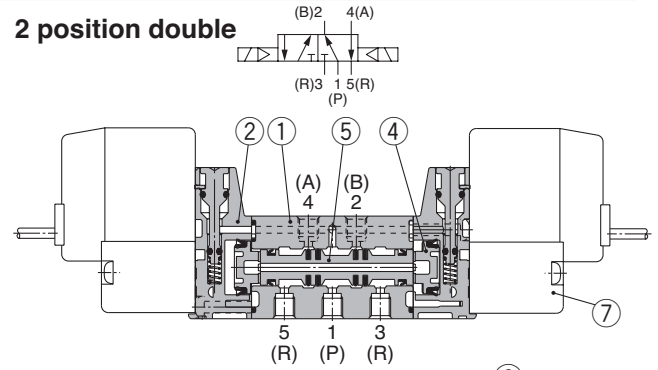

3 position closed center/exhaust center/pressure center

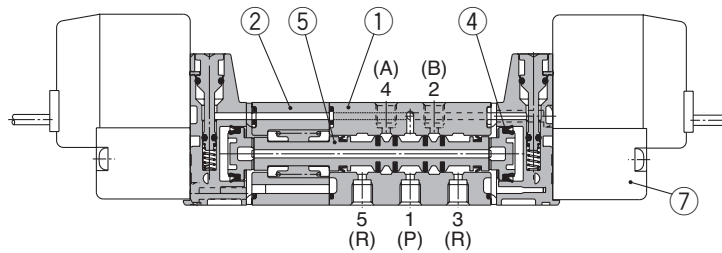
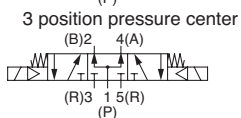
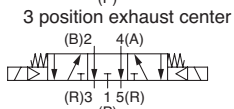
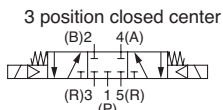

(This figure shows a closed center type.)

Component Parts

No.	Description	Material	Note
1	Body	Zinc die-casted	White
2	Piston plate	Resin	White
3	End cover	Resin	White
4	Piston	Resin	
5	Spool valve assembly	Aluminum, H-NBR	

Replacement Parts

No.	Description	No.	Note
6	Sub-plate	SYJ3000-22-1-Q	Zinc die-casted
7	Pilot valve	V111 (T) - □□□	

How to Order Pilot Valve Assembly

V111 □ — 5 G □

Coil specifications

-	Standard
T	With power saving circuit (24, 12 VDC only)

* Power saving circuit is not available in the case of W□ type.

Rated voltage

5	24 VDC
6	12 VDC
V	6 VDC
S	5 VDC
R	3 VDC

* For type W□, DC voltage is only available.

Light/surge voltage suppressor

-	Without light/surge voltage suppressor
S	With surge voltage suppressor
Z	With light/surge voltage suppressor
R	With surge voltage suppressor (Non-polar type)
U	With light/surge voltage suppressor (Non-polar type)

* Power saving circuit is only available in the "Z" type.

Electrical entry

G	Grommet, 300 mm lead wire
H	Grommet, 600 mm lead wire
L	L plug connector
LN	L plug connector
LO	L plug connector
M	M plug connector
MN	M plug connector
MO	M plug connector
WO	M8 connector
W□	M8 connector

* For connector cable of M8 connector, refer to back page 10.
Note 1) Enter the cable length symbols in □. Please be sure to fill in the blank referring to back page 10.

How to Order Connector Assembly for L/M Plug Connector

For DC : SY100-30-4A- □

Without lead wire (with connector and 2 of sockets only) : SY100-30-A

Lead wire length

-	300 mm
6	600 mm
10	1000 mm
15	1500 mm
20	2000 mm
25	2500 mm
30	3000 mm
50	5000 mm

How to Order M8 Connector Cable

V100-49-1- □

Cable length

1	300 mm
2	500 mm
3	1000 mm
4	2000 mm
7	5000 mm

Series SYJ3000

2 Position Single

Grommet (G), (H): SYJ3120-□^G□□-M3-Q

With bracket:
SYJ3120-□^G□□-M3-F-Q

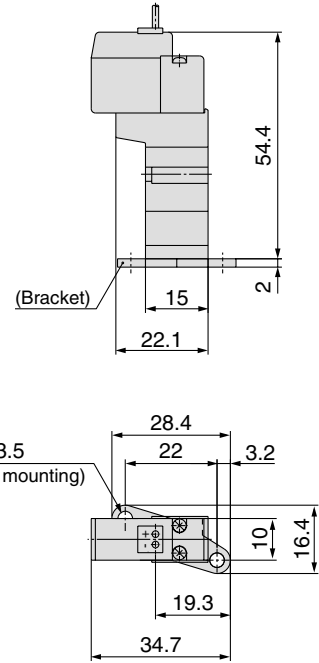
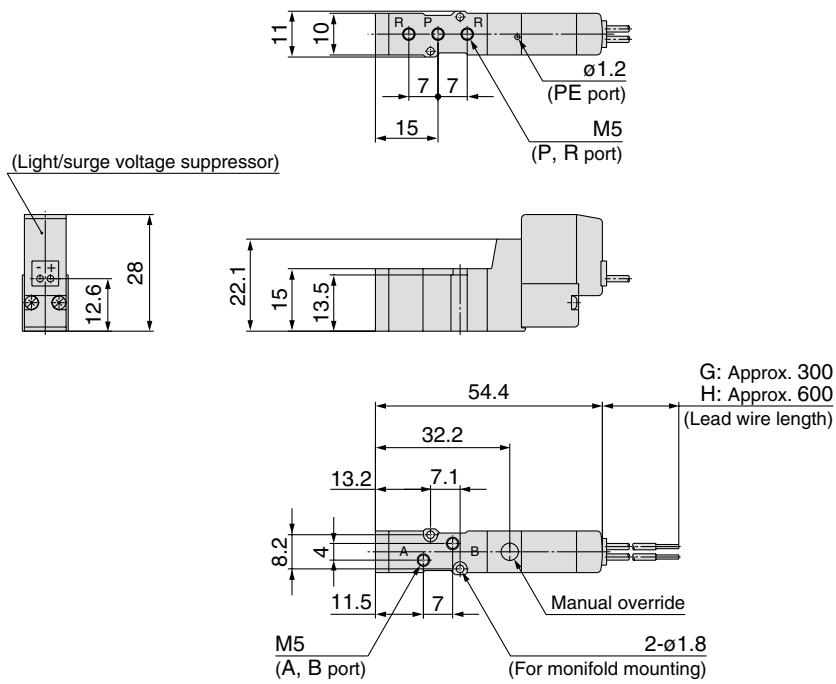

L plug connector (L):
SYJ3120-□L□□-M3 (-F)-Q

M plug connector (M):
SYJ3120-□M□□-M3 (-F)-Q

M8 connector (WO):
SYJ3120-□WO□□-M3 (-F)-Q

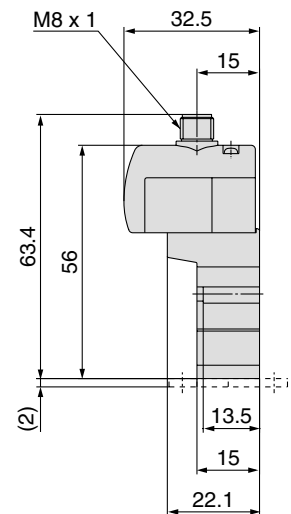
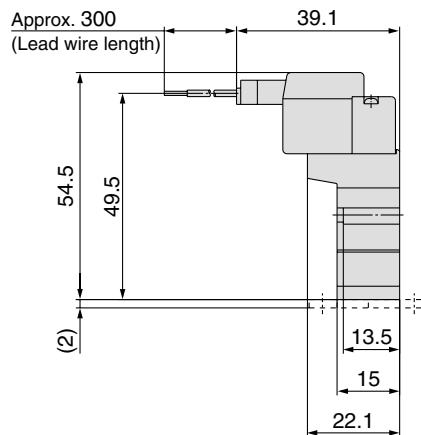
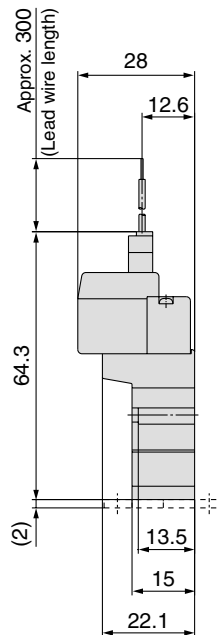

Refer to back page 11 for dimensions with connector cable.

2 Position Double

Grommet (G), (H): SYJ3220-□^G□□-M3 (-F)-Q

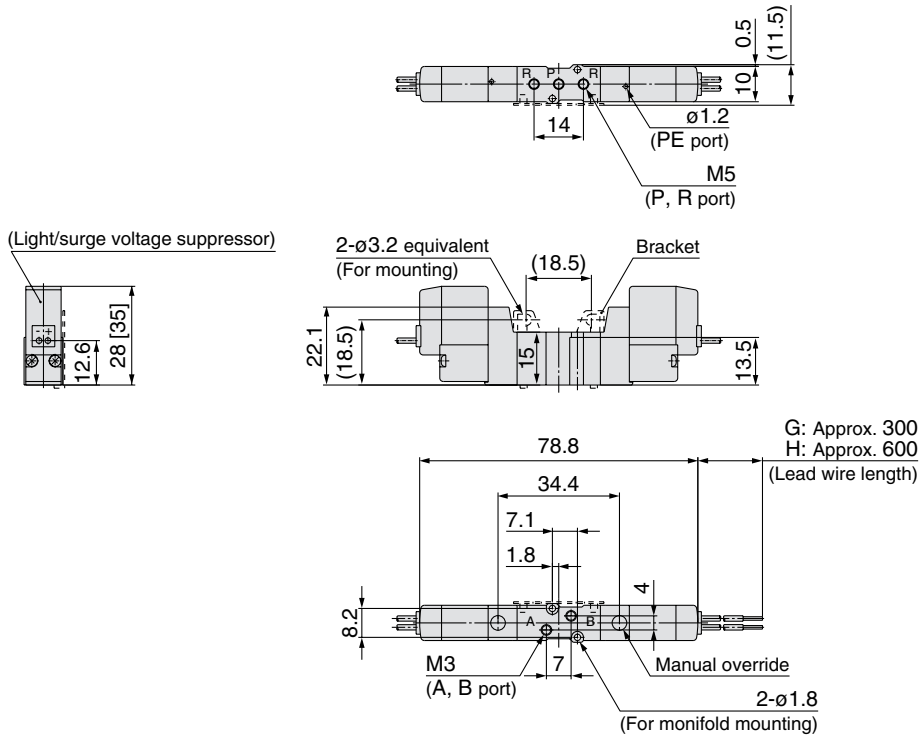

L plug connector (L):
SYJ3220-□L□□-M3 (-F)-Q

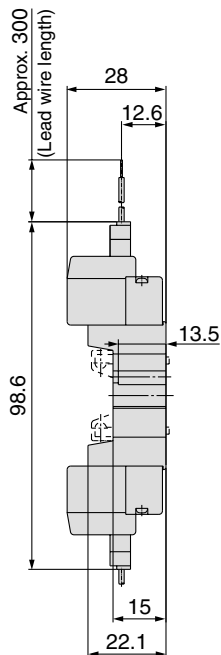

M plug connector (M):
SYJ3220-□M□□-M3 (-F)-Q

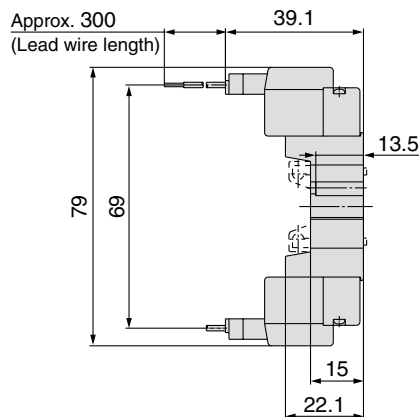

M8 connector (WO):
SYJ3220-□WO□□-M3 (-F)-Q

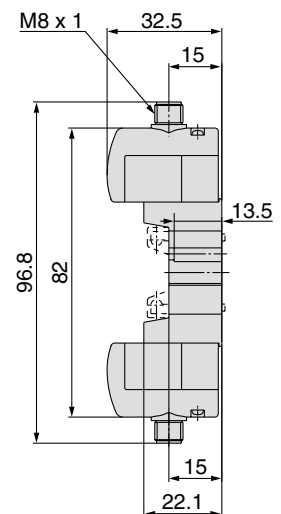

Refer to back page 11 for dimensions with connector cable.

Series SYJ3000

3 Position Closed Center/Exhaust Center/Pressure Center

Grommet (G), (H): SYJ3 $\frac{3}{4}$ 20-□^G□□-M3 (-F)-Q

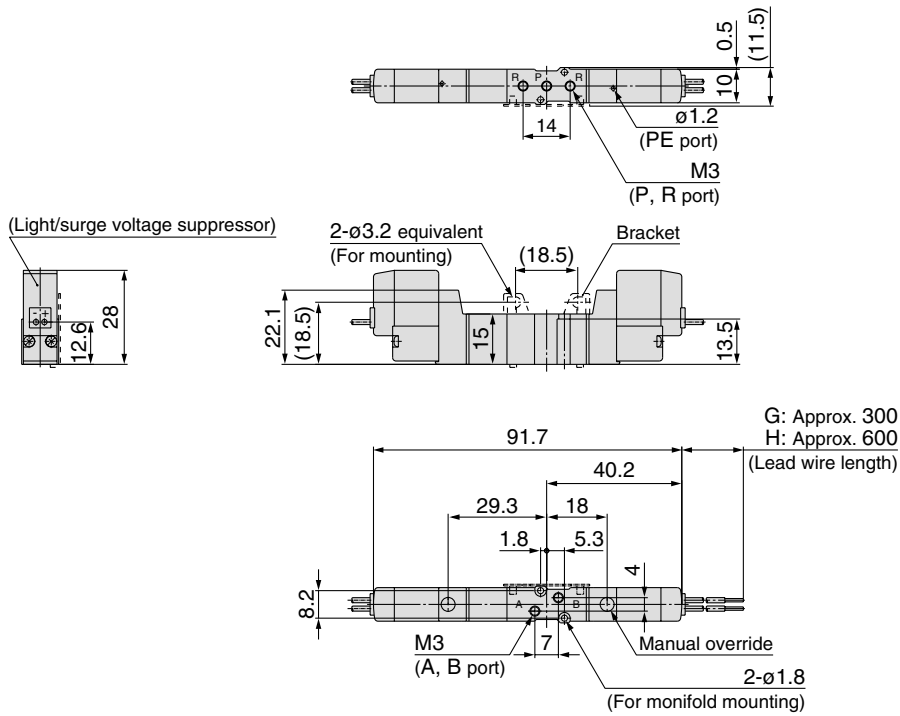

L plug connector (L):
SYJ3 $\frac{3}{4}$ 20-□L□□-M3 (-F)-Q

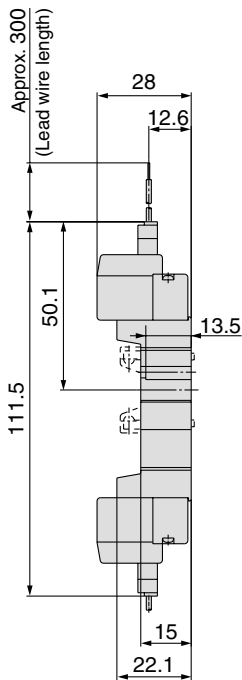

M plug connector (M):
SYJ3 $\frac{3}{4}$ 20-□M□□-M3 (-F)-Q

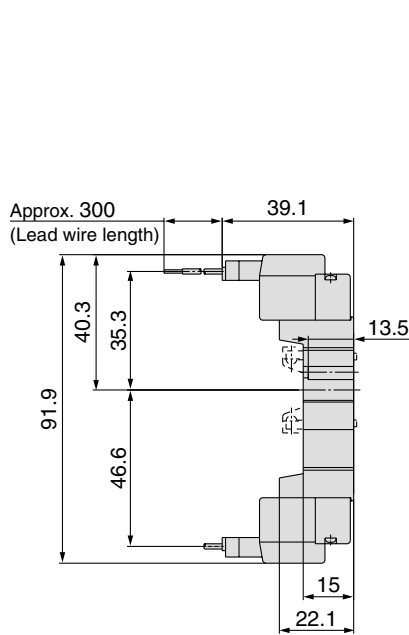

M8 connector (WO):
SYJ3 $\frac{3}{4}$ 20-□WO□□-M3 (-F)-Q

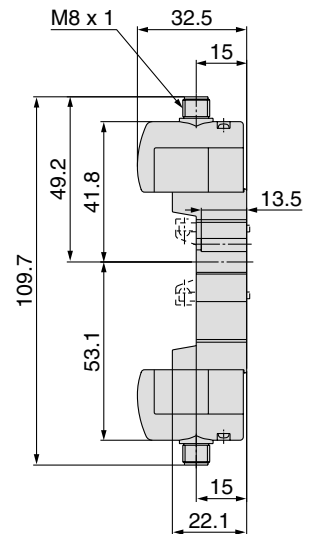

Refer to back page 11 for dimensions with connector cable.

2 Position Single

Grommet (G), (H): SYJ3140-□_H□□-M5-Q

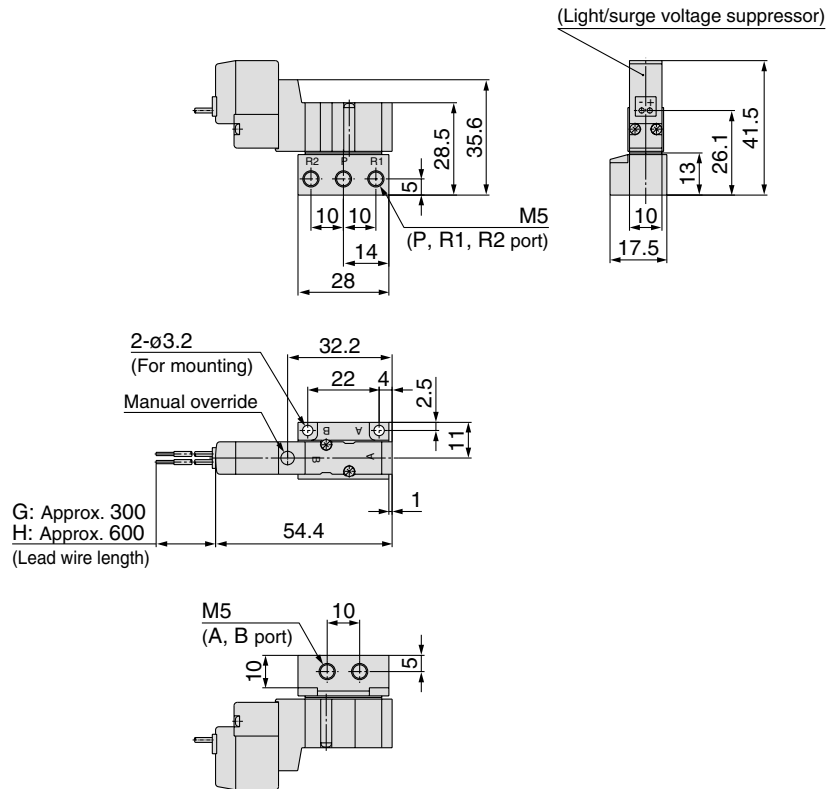

L plug connector (L):
SYJ3140-□L□□-M5-Q

M plug connector (M):
SYJ3140-□M□□-M5-Q

M8 connector (WO):
SYJ3140-□WO□□-M5-Q

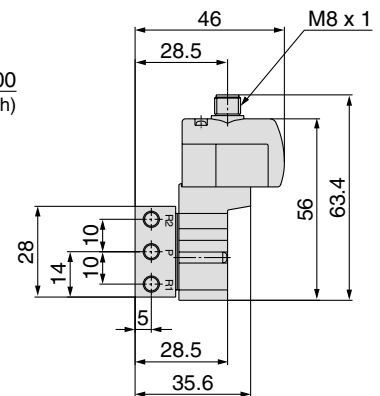
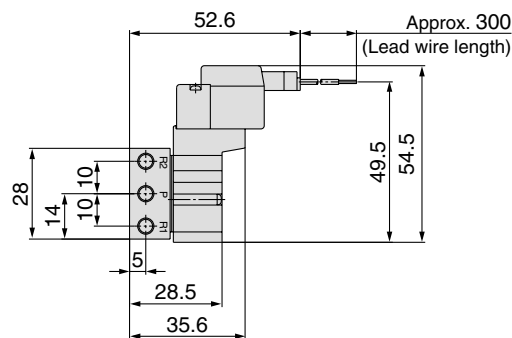
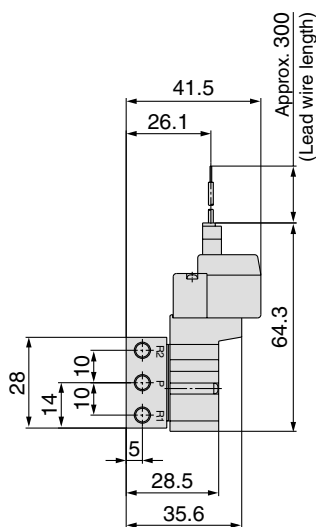

Refer to back page 11 for dimensions with connector cable.

Series SYJ3000

2 Position Double

Grommet (G), (H): SYJ3240-□_G□□-M5-Q

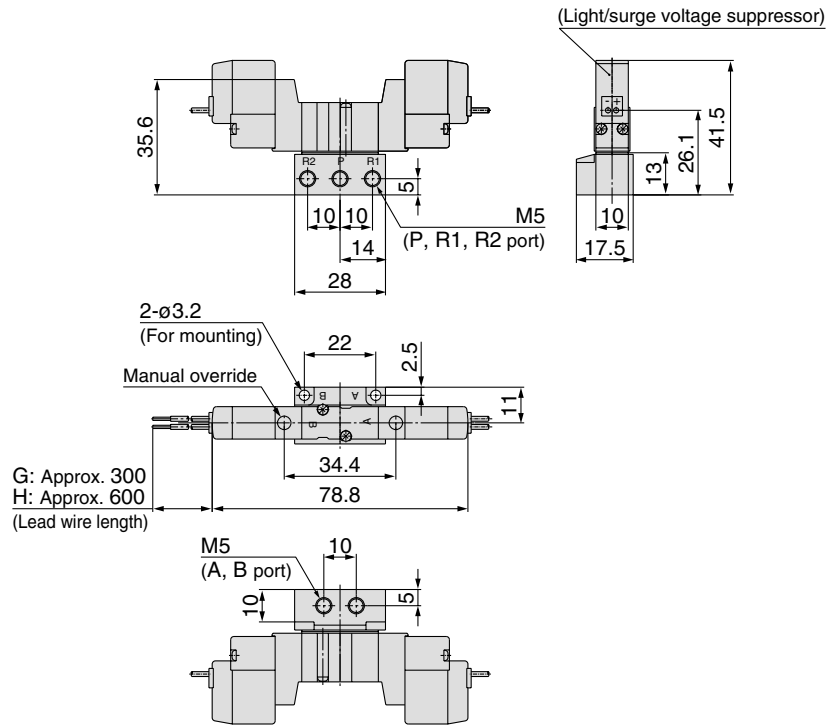

L plug connector (L):
SYJ3240-□L□□-M5-Q

M plug connector (M):
SYJ3240-□M□□-M5-Q

M8 connector (WO):
SYJ3240-□WO□□-M5-Q

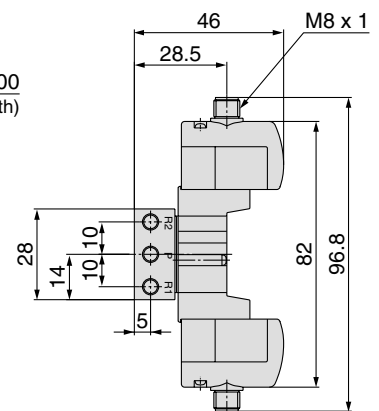
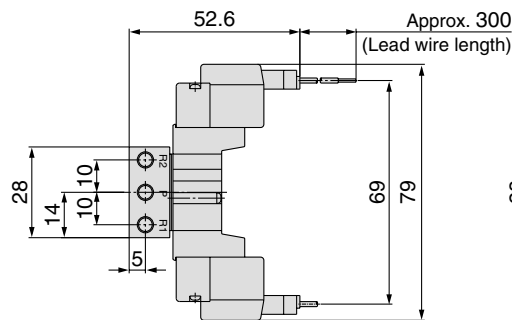
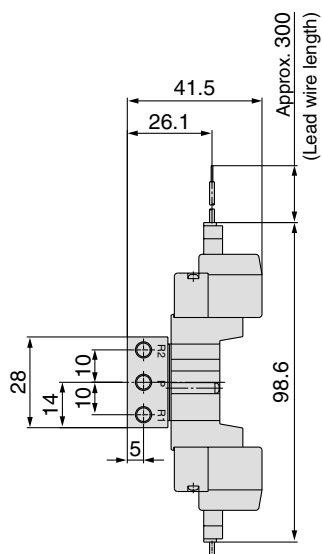

Refer to back page 11 for dimensions with connector cable.

3 Position Closed Center/Exhaust Center/Pressure Center

Grommet (G), (H): SYJ3³/₅40-□^G□□-M5-Q

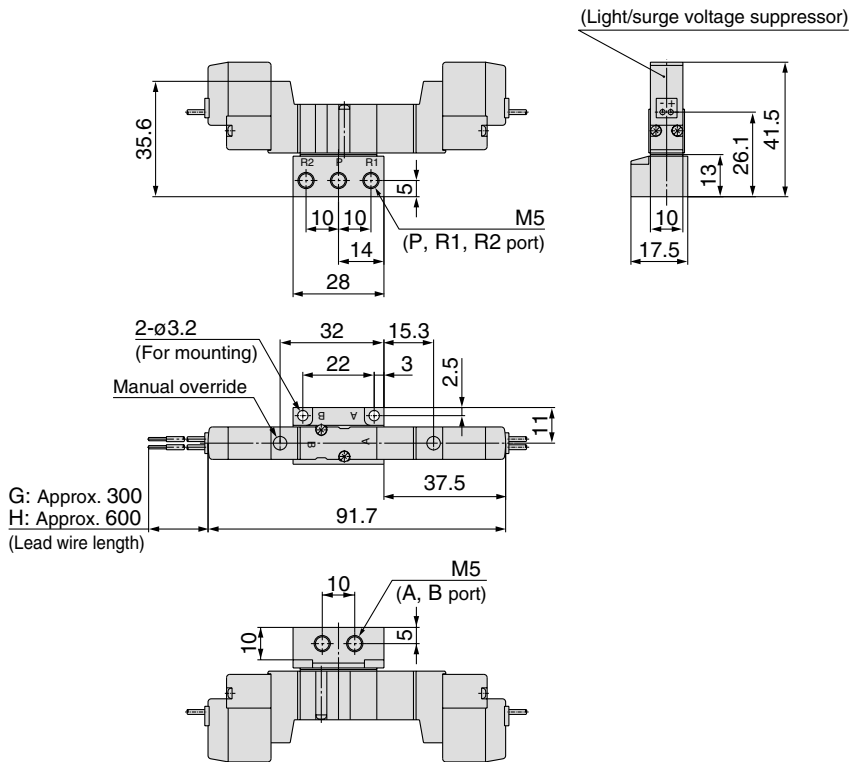

L plug connector (L):
SYJ3³/₅40-□L□□-M5-Q

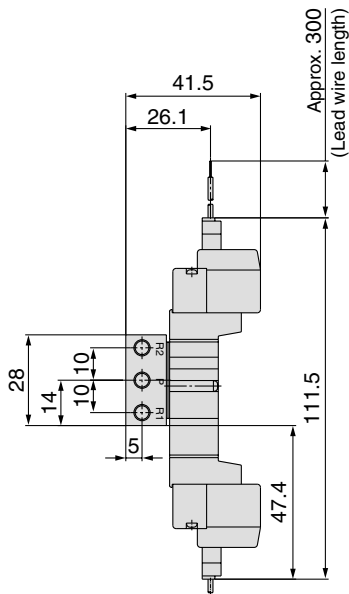

M plug connector (M):
SYJ3³/₅40-□M□□-M5-Q

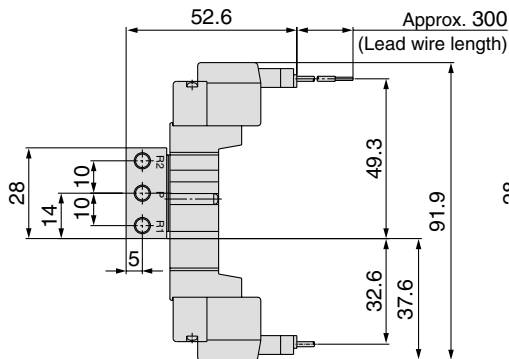

M8 connector (WO):
SYJ3³/₅40(R)-□WO□□-M5□-Q

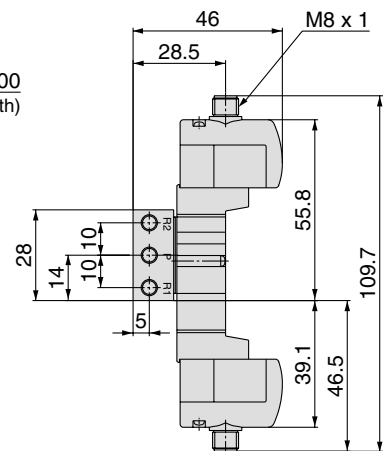

Refer to back page 11 for dimensions with connector cable.

Series SYJ3000 Manifold Specifications

Manifold Standard

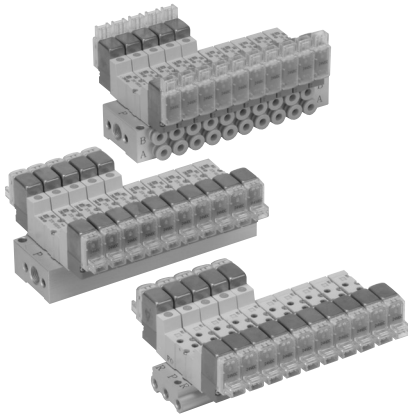

Manifold Specifications

Model		Type 20	Type 31, S31	Type 32, S32	Type 41, S41	Type 46, S46
Manifold type		Single base/B mount				
P (SUP), R (EXH)		Common SUP/Common EXH				Common SUP Individual EXH
Valve stations		2 to 20 stations				
A, B port Porting specifications	Location	Valve	Base			
	Direction	Top	Side			
Port size	P, R port	M5		1/8		P: 1/8 R: M5
	A, B port	M3		M5, C4 (One-touch fitting for ø4)		

Flow Characteristics

Manifold			Port size		Flow characteristics								Effective area (mm ²)
					1→4/2 (P→A/B)				4/2→5/3 (A/B→R)				
Body ported for internal pilot	Type	SYJ3□□□	1(P), 5/3(R) Port	2(B), 4(A) Port	C [dm ³ /(s·bar)]	b	Cv	Q _l /min (ANR) [*]	C [dm ³ /(s·bar)]	b	Cv	Q _l /min (ANR) [*]	
	Type SS5YJ3-20	SYJ3□2□	M5	M3	—	—	—	—	—	—	—	—	0.9
	Type SS5YJ3- ³¹ _{S31}	SYJ3□3□	M5	M3	—	—	—	—	—	—	—	—	0.9
Base mounted for internal pilot	Type SS5YJ3-32-M5	SYJ3□3□	1/8	M5	0.25	0.19	0.060	60	0.32	0.25	0.077	79	—
	Type SS5YJ3-32-C4			C4	0.25	0.18	0.059	59	0.30	0.27	0.075	75	—
	Type SS5YJ3-S32-M5	SYJ3□3□	1/8	M5	0.25	0.26	0.060	62	0.29	0.15	0.062	68	—
	Type SS5YJ3-S32-C4			C4	0.24	0.21	0.057	58	0.27	0.18	0.062	64	—
	Type SS5YJ3-41-M5	SYJ3□4□	1/8	M5	0.32	0.25	0.081	79	0.33	0.19	0.079	79	—
	Type SS5YJ3-41-C4			C4	0.32	0.28	0.079	80	0.35	0.24	0.084	86	—
	Type SS5YJ3-S41-M5	SYJ3□4□	1/8	M5	0.33	0.29	0.082	83	0.34	0.17	0.081	80	—
	Type SS5YJ3-S41-C4			C4	0.32	0.27	0.079	80	0.34	0.24	0.084	83	—
	Type SS5YJ3-46-M5	SYJ3□4□	1/8	M5	0.20	0.25	0.048	49	0.10	0.12	0.024	23	—
	Type SS5YJ3-46-C4			C4	0.21	0.27	0.050	52	0.21	0.13	0.047	48	—
	Type SS5YJ3-S46-M5	SYJ3□4□	M5	M5	0.20	0.25	0.048	49	0.19	0.16	0.024	45	—
	Type SS5YJ3-S46-C4			C4	0.22	0.34	0.057	57	0.10	0.090	0.024	23	—



Note) Value at manifold base mounted, 2 position single operating

* These values have been calculated according to ISO6358 and represent the flow rate measured in standard conditions at an upstream of 0.6MPa (relative pressure) and a differential pressure of 0.1MPa.

How to Order Manifold (Example)

Instruct by specifying the valves and blanking plate assembly to be mounted on the manifold along with the manifold base model no.

Example:

● SS5YJ3-20-03-Q 1 set (Manifold base) ● SS5YJ3-S41-03-C4-Q 1 set (Manifold base)

* SYJ3120-5G-M3-Q 2 sets (Valve) * SYJ3140-5LZ-Q 2 sets (Valve)

* SYJ3000-21-1A-Q 1 set (Blanking plate assembly) * SYJ3000-21-2A-Q 1 set (Blanking plate assembly)

↳ The asterisk denotes the symbol for assembly. Prefix it to the part nos. of the solenoid valve, etc.

* Use manifold specification sheet.

Flat Ribbon Cable Manifold

- Multiple valve wiring is simplified through the use of the flat cable connector.

- Clean appearance**

In the case of a flat ribbon cable type, each valve is wired on the print board of manifold base to allow the external wiring to be piped all together with 26 pins MIL connector.

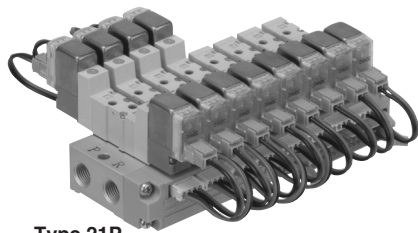

Type 21P

Flat Ribbon Cable Manifold Specifications

Model		Type 21P	Type 32P
Manifold type		Single base/B mount	
P (SUP), R (EXH)		Common SUP, Common EXH	
Valve stations		4 to 12 stations	
A, B port Porting specifications	Location	Valve	Base
	Direction	Top	Side
Port size	P, R port	1/8	
	A, B port	M3	M5, C4 (One-touch fitting for Ø4)
Applicable flat ribbon cable connector		Socket: 26 pins MIL type with strain relief (MIL-C-83503)	
Internal wiring		In common between +COM and -COM (Z type: +COM only)	
Rated voltage		24, 12 VDC	



Note) The withstand voltage specification for the wiring unit section conforms to JIS C 0704, Grade 1 or its equivalent.

Flow Characteristics

Manifold			Port size		Flow characteristics						Effective area (mm ²)	
					1→4/2 (P→A/B)			4/2→5/3 (A/B→R)				
Body ported for internal pilot	Type SS5YJ3-21P	SYJ3□23	1(P), 5/3(R) Port	2(B), 4(A) Port	C [dm ³ /(s·bar)]	b	Cv	Q[l/min (ANR)]*	C [dm ³ /(s·bar)]	b	Q[l/min (ANR)]*	
Base mounted for internal pilot	Type SS5YJ3-32P-M5	SYJ3□33	1/8	M5	0.25	0.19	0.060	60	0.32	0.25	79	—
	Type SS5YJ3-32P-C4			C4	0.25	0.18	0.059	59	0.3	0.27	75	—

Note) Value at manifold base mounted, 2 position single operating

* These values have been calculated according to ISO6358 and represent the flow rate measured in standard conditions at an upstream of 0.6MPa (relative pressure) and a differential pressure of 0.1MPa.

How to Order Manifold

- **SS5YJ3-32P-07-C4-Q**..... 1 pc. (Manifold base) * **SYJ3000-21-4A-Q**.....1 pc. (Blanking plate assembly)
- * **SYJ3133-5LOU-Q** 3 pcs. (Valve) * **SY3000-37-28A-Q**.....3 pcs. (Connector assembly)
- * **SYJ3233-5LOU-Q** 3 pcs. (Valve) * **SY3000-37-29A-Q**.....3 pcs. (Connector assembly)

The asterisk denotes the symbol for assembly. Prefix it to the part nos. of the solenoid valve, etc.

* Use manifold specification sheet.

How to Order Valve



How to Order Connector Assembly

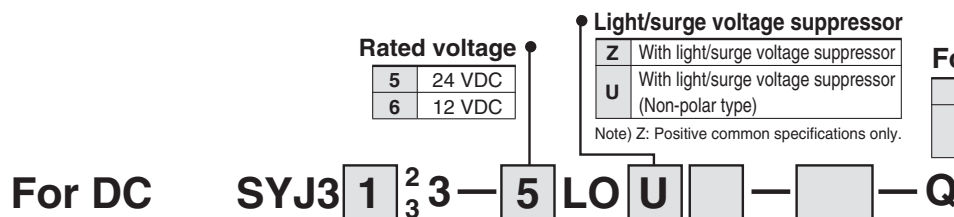

Type of actuation

1	2 position single
2	2 position double
3	3 position closed center
4	3 position exhaust center
5	3 position pressure center

A, B port size

Symbol	Port size
-	Base mounted
M3	M3

Manual override

-	Non-locking push type
D	Push-turn locking slotted type
E	Push-turn locking lever type

For 12, 24 VDC

Single solenoid	SY3000-37-28A
Double solenoid, 3 position type	SY3000-37-29A

Series SYJ3000/5000/7000

Flat Ribbon Cable Connector

AXT100-FC26-¹/₂/₃

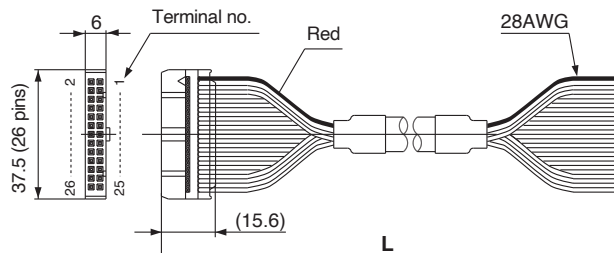

Flat ribbon cable connector

Cable length (L)	Assembly part no.
	26 pins
1.5 m	AXT100-FC26-1
3 m	AXT100-FC26-2
5 m	AXT100-FC26-3

- * When using a standard commercial connector, use a 26-pin type connector conforming to MIL-C-83503 with strain relief.
- * Cannot be used for movable wiring
- * Lengths other than the above are also available. Please contact SMC for details.

Connector Manufacturer's Example

- HIROSE ELECTRIC CO., LTD.
- 3M Japan Limited
- Fujitsu Limited
- Japan Aviation Electronics Industry, Limited
- J.S.T. Mfg. Co., Ltd.
- Oki Electric Cable Co., Ltd.

Specified Layout

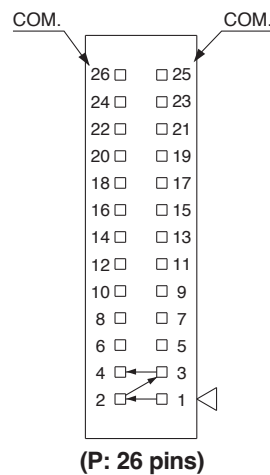

A mixture of single and double wiring can be specified on the manifold specification sheet. The maximum number of stations is determined according to the number of solenoids. The total number of solenoids should be 24 or less for P and PC. 1 solenoid is required for the 2-position single, and 2 solenoids for the 2-position double, and 3-position.

Common SUP/Common EXH



Note) For more than 10 stations, supply air to both sides of P port and exhaust air from both sides of R port.

Type 20 (5 Port/Body ported)

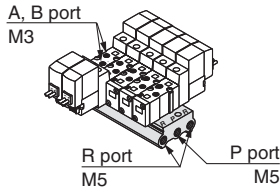

How to Order

SS5YJ3-20-05-Q

Number of stations

02	2 stations
:	:
20	20 stations

Applicable solenoid valve
SYJ3□20-□□□□-M3-Q
SYJ3□23-□□□□-M3-Q

Applicable blanking plate assembly
SYJ3000-21-1A-Q

Type 31 (4 Port/Base mounted)

Type 31 Type S31 (Single solenoid coil is on same side as the A,B port.)

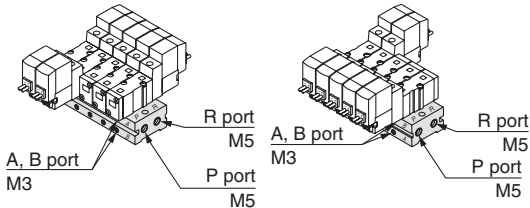

How to Order

SS5YJ3-31-05-M3-Q

Valve mounting direction

-	Single solenoid coil is on opposite side as the A,B port.
S	Single solenoid coil is on same side as the A,B port.

Stations

02	2 stations
:	:
20	20 stations

Applicable solenoid valve
SYJ3□30-□□□□-Q
SYJ3□33-□□□□-Q

Type 32 (4 Port/Base mounted)

Type 32 Type S32 (Single solenoid coil is on same side as the A,B port.)

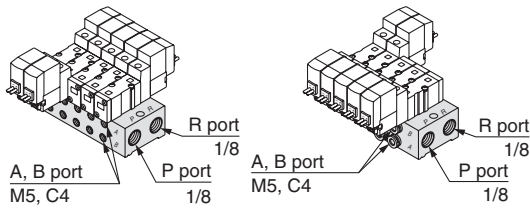

How to Order

SS5YJ3-32-05-M5-Q

Valve mounting direction

-	Single solenoid coil is on opposite side as the A,B port.
S	Single solenoid coil is on same side as the A,B port.

Stations

02	2 stations
:	:
20	20 stations

P, R port thread type

-	Rc
F	G
N	NPT
T	NPTF

A, B port size

M5	M5
C4	One-touch fitting for ø4
N3	One-touch fitting for ø5/32"

Applicable blanking plate assembly
SYJ3000-21-2A-Q

Type 41 (5 Port/Base mounted)

Type 41 Type S41 (Single solenoid coil is on same side as the A,B port.)

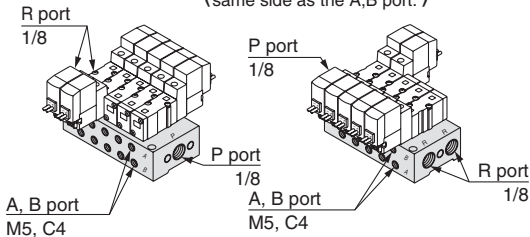

How to Order

SS5YJ3-41-05-C4-Q

Valve mounting direction

-	Single solenoid coil is on opposite side as the A,B port.
S	Single solenoid coil is on same side as the A,B port.

Stations

02	2 stations
:	:
20	20 stations

P, R port thread type

-	Rc
F	G
N	NPT
T	NPTF

A, B port size

M5	M5
C4	One-touch fitting for ø4
N3	One-touch fitting for ø5/32"

Applicable solenoid valve
SYJ3□40-□□□□-Q
SYJ3□43-□□□□-Q

Applicable blanking plate assembly
SYJ3000-21-2A-Q

Common SUP/Individual EXH



Note) For more than 10 stations, supply air to both sides of P port.

Type 46 (5 Port/Base mounted)

Type 46 Type S46 (Single solenoid coil is on same side as the A,B port.)

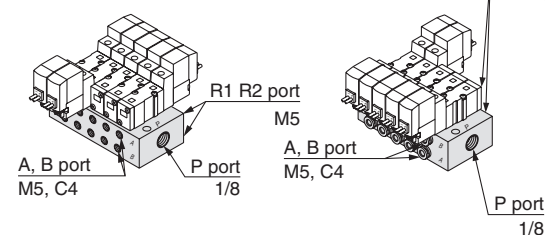

How to Order

SS5YJ3-46-05-M5-Q

Valve mounting direction

-	Single solenoid coil is on opposite side as the A,B port.
S	Single solenoid coil is on same side as the A,B port.

Stations

02	2 stations
:	:
20	20 stations

P port thread type

-	Rc
F	G
N	NPT
T	NPTF

A, B port size

M5	M5
C4	One-touch fitting for ø4
N3	One-touch fitting for ø5/32"

Applicable solenoid valve
SYJ3□40-□□□□-Q
SYJ3□43-□□□□-Q

Applicable blanking plate assembly
SYJ3000-21-2A-Q

Flat Ribbon Cable Manifold

Common SUP/Common EXH



Note) For more than 10 stations, supply air to both sides of P port and exhaust air from both sides of R port.

Type 21P

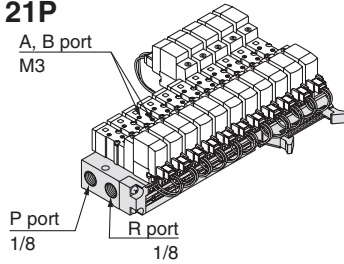

How to Order

SS5YJ3-21P-07 - **Q**

Stations	
04	4 stations
:	:
12	12 stations

P, R port thread type

-	Rc
00F	G
00N	NPT
00T	NPTF

Applicable solenoid valve
Refer to page 12.

Applicable connector assembly
Refer to page 12.

Applicable blanking plate assembly
SYJ3000-21-3A-Q
(With dust cap)

Type 32P

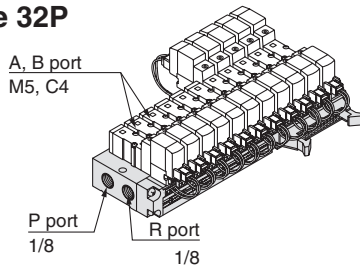

How to Order

SS5YJ3-32P-07 - **C4** - **Q**

Stations	
04	4 stations
:	:
12	12 stations

A, B port size

M5	M5
C4	One-touch fitting for $\phi 4$
N3	One-touch fitting for $\phi 5/32$

P, R port thread type

-	Rc
F	G
N	NPT
T	NPTF

Applicable solenoid valve
Refer to page 12.

Applicable connector assembly
Refer to page 12.

Applicable blanking plate assembly
SYJ3000-21-3A-Q
(With dust cap)

Mixed Installation of the SYJ300 and the SYJ3000 Valves on the Same Manifold

Series SYJ300 valves can be mounted on the manifolds for Series SYJ3000.

① SS5YJ3-20, SS5YJ3-21P

The 3 port valve can be used by simply sealing off the unused "R" port with rubber plug SYJ3000-33-1.

Applicable solenoid valves:

Series SYJ312, SYJ312M, SYJ322, SYJ322M

② SS5YJ3-31, -S31, SS5YJ3-32, -S32, SS5YJ3-46, -S46, SS5YJ3-32P

The 3 port valve can be used without modification. The A port of the valve will flow out of the B port of the manifold.

Applicable solenoid valves:

Series SYJ314, SYJ314M, SYJ324, SYJ324M

③ SS5YJ3-41, -S41

The 3 port valve can be used on the 4 port manifold by simply sealing off the unused "R" port with rubber plug SYJ3000-33-1. The A port of the valve will flow out of the B port of the manifold.

Applicable solenoid valves:

Series SYJ314, SYJ314M, SYJ324, SYJ324M

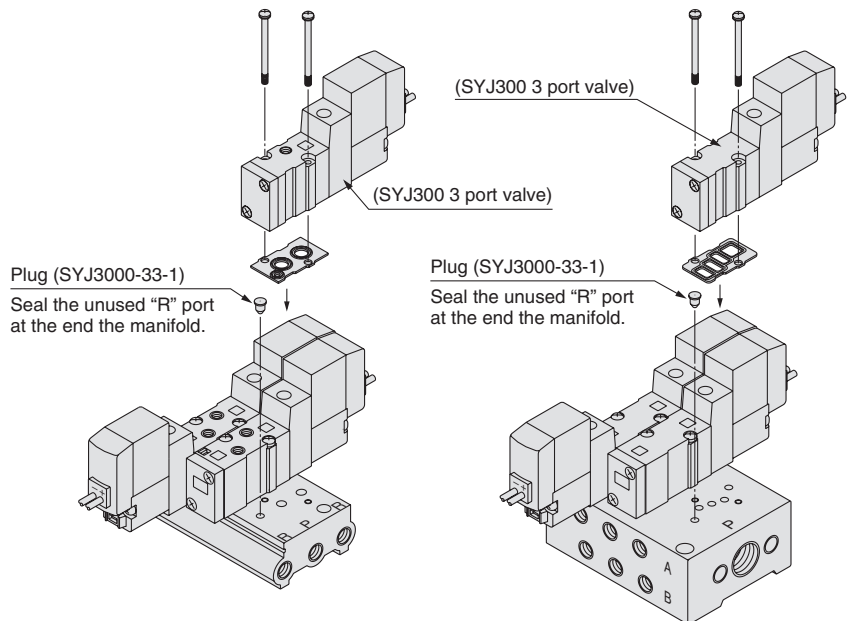

Type SS5YJ3-20

Type SS5YJ3-41

A port of the 3 port valve flows out of the manifold B port.

⚠ Caution

Mounting screw tightening torques

M1.7: 0.12 N·m

Use caution to the assembly orientation for solenoid valves, gasket, and optional parts.

Series SYJ3000

Combinations of Solenoid Valve, Manifold Gasket and Manifold Base

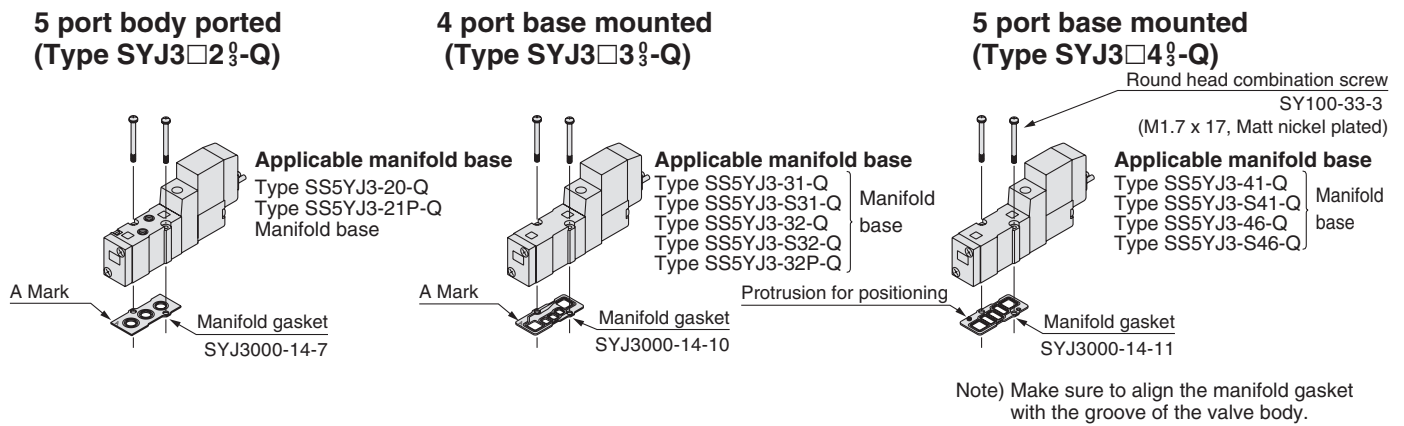

Combination of Blanking Plate Assembly and Manifold Base

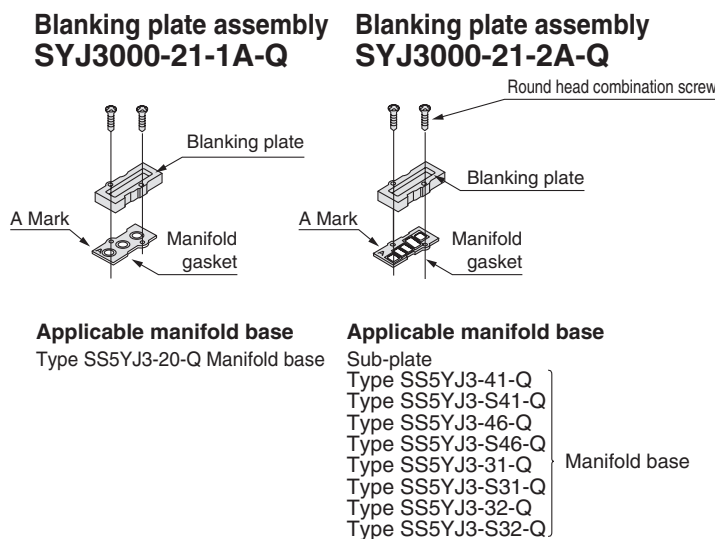

Note) Manifold gasket "SYJ3000-14-2" can be used with the following manifold bases.

Manifold base of

Type	SS5YJ3-31-Q
Type	-S31-Q
Type	-32-Q
Type	-S32-Q

Difference between SYJ3□3 $\frac{0}{3}$ and SYJ3□4 $\frac{0}{3}$

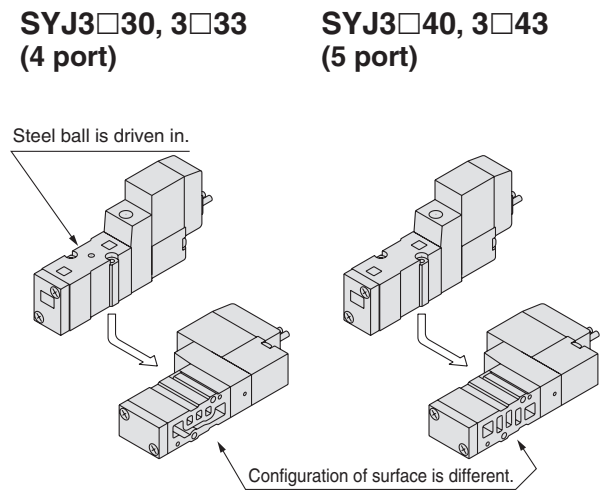

Blanking plate assembly SYJ3000-21-4A-Q

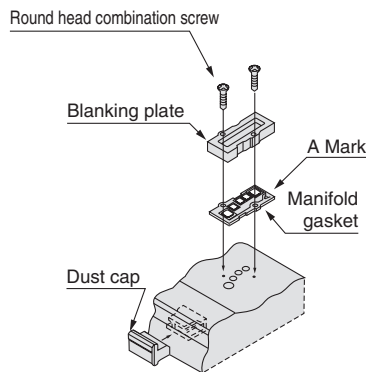

Applicable manifold base
Type SS5YJ3-32P-Q
Manifold base

Blanking plate assembly SYJ3000-21-3A-Q

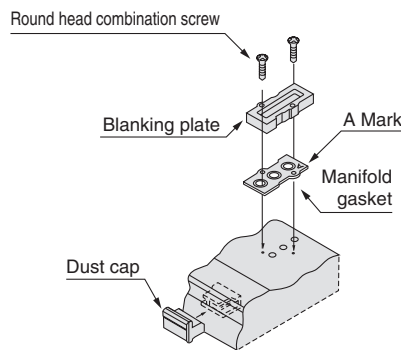

Applicable manifold base
Type SS5YJ3-21P-Q
Manifold base

Caution

Mounting screw tightening torques

M1.7: 0.12 N·m

Use caution to the assembly orientation for solenoid valves, gasket, and optional parts.

Type 20 Manifold: Top Ported/SS5YJ3-20- Stations -Q

Grommet (G)

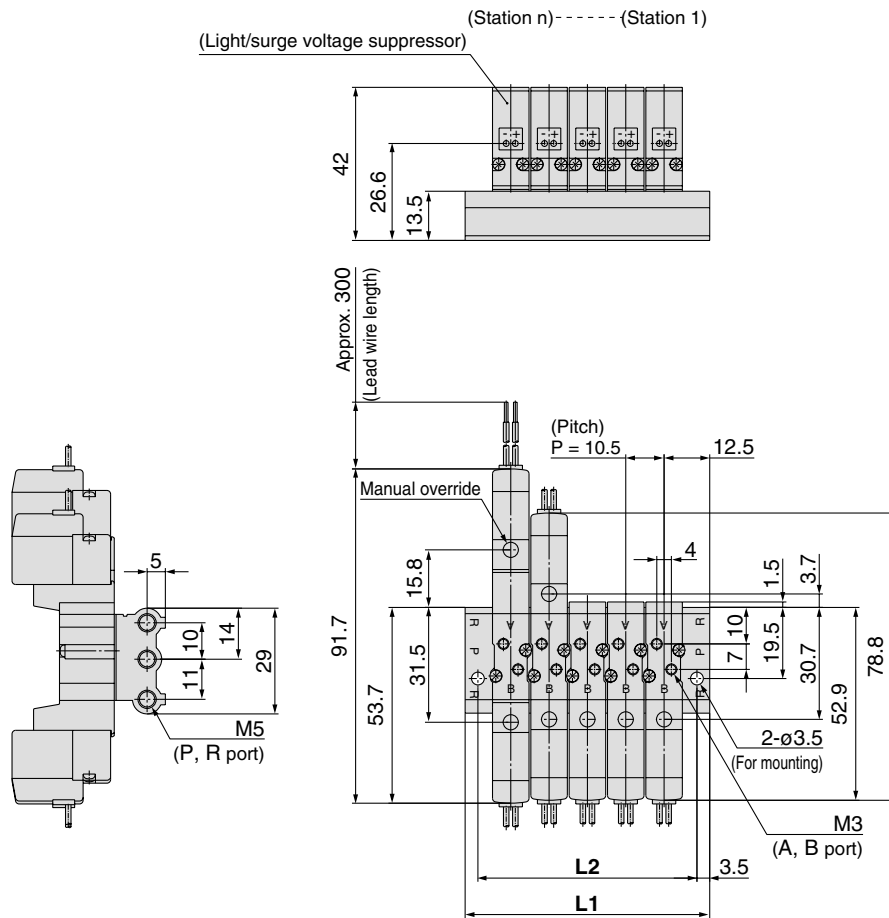

L plug connector (L)

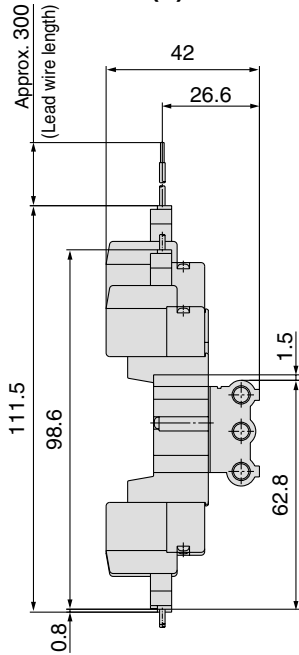

M plug connector (M)

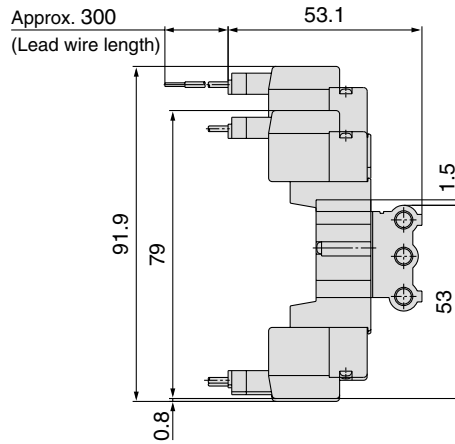

M8 connector (WO)

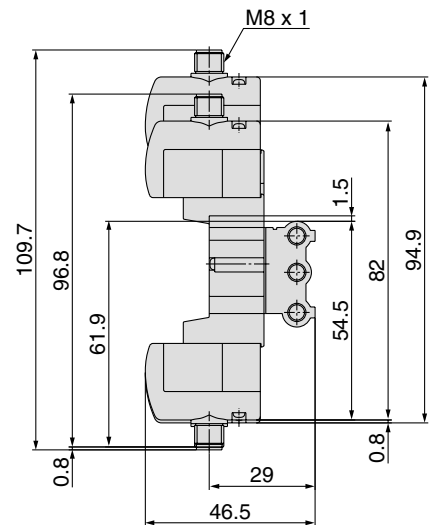

Refer to back page 11 for dimensions with connector cable.

Station n	Station 2	3	4	5	6	7	8	9	10	11	12	13	14	15	16	17	18	19	Station 20
L1	35.5	46	56.5	67	77.5	88	98.5	109	119.5	130	140.5	151	161.5	172	182.5	193	203.5	214	224.5
L2	28.5	39	49.5	60	70.5	81	91.5	102	112.5	123	133.5	144	154.5	165	175.5	186	196.5	207	217.5

Series SYJ3000

Type 31 Manifold: Side Ported/SS5YJ3-31- Stations -M3-Q

Grommet (G)

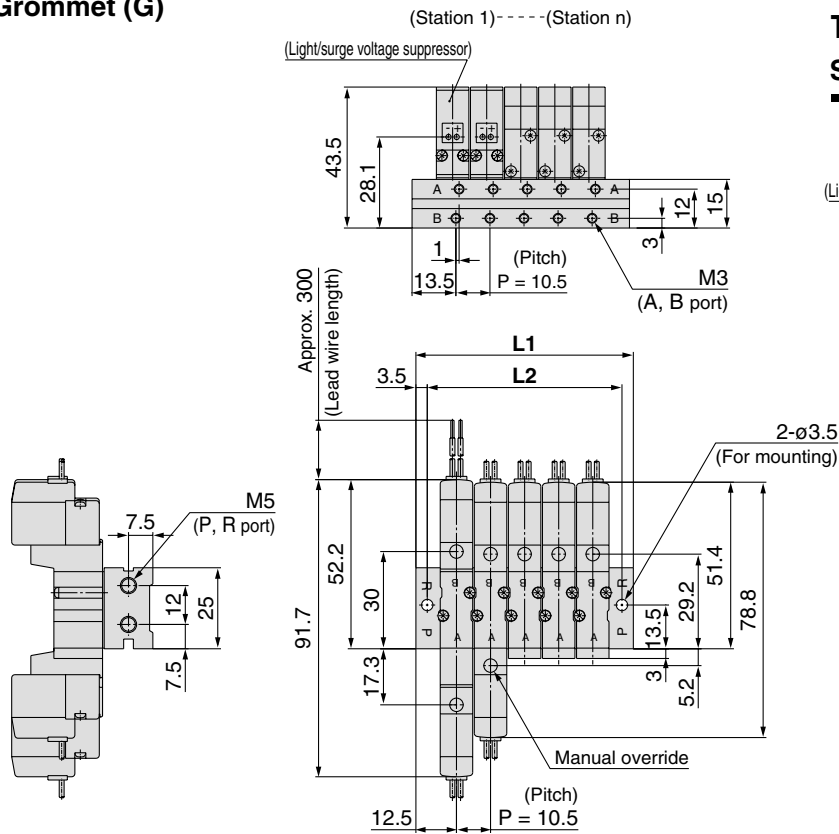

Type S31 Manifold: Side Ported SS5YJ3-S31- Stations -M3-Q

(Single solenoid coil is on same side as the A,B port.)

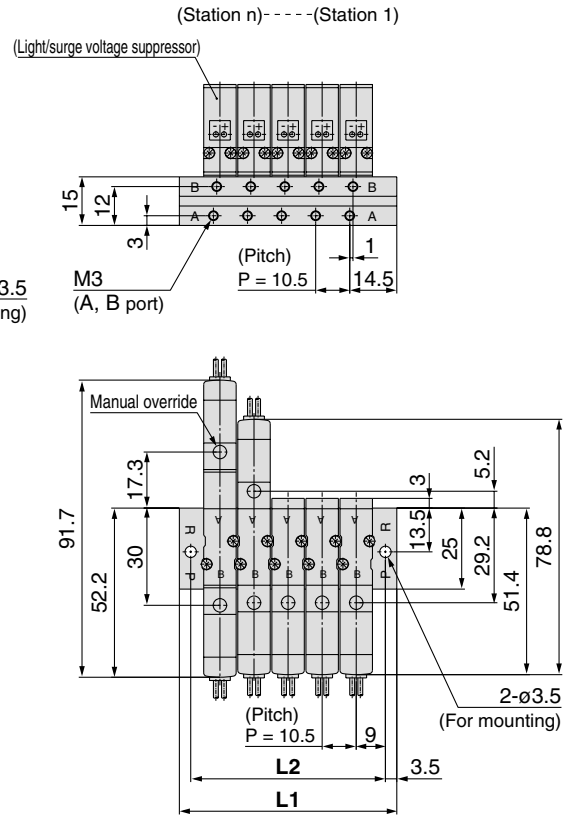

L plug connector (L)

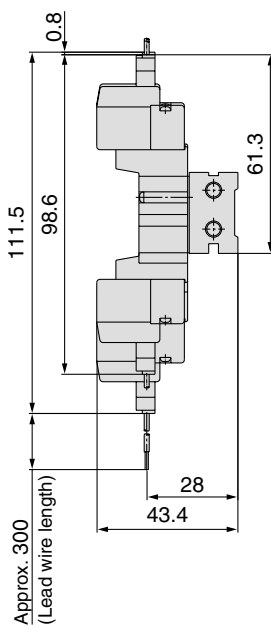

M plug connector (M)

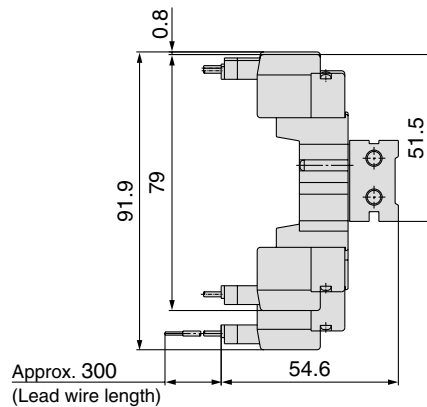

M8 connector (WO)

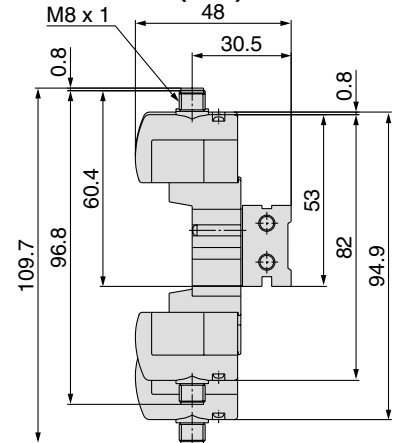

Refer to back page 11 for dimensions with connector cable.

Station n	Station 2	3	4	5	6	7	8	9	10	11	12	13	14	15	16	17	18	19	Station 20
L1	35.5	46	56.5	67	77.5	88	98.5	109	119.5	130	140.5	151	161.5	172	182.5	193	203.5	214	224.5
L2	28.5	39	49.5	60	70.5	81	91.5	102	112.5	123	133.5	144	154.5	165	175.5	186	196.5	207	217.5

Type 32 Manifold: Side Ported/SS5YJ3-32- Stations -M5, $C4$ $N3$ □ -Q

Grommet (G) For M5

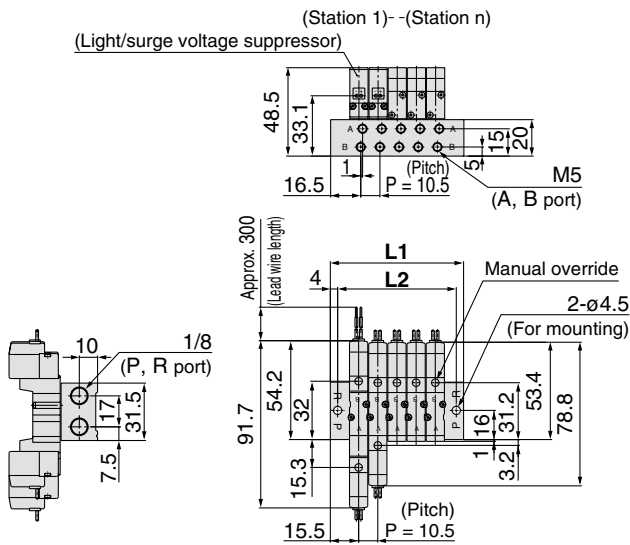

For $C4$ $N3$ □ (Built-in one-touch fitting)

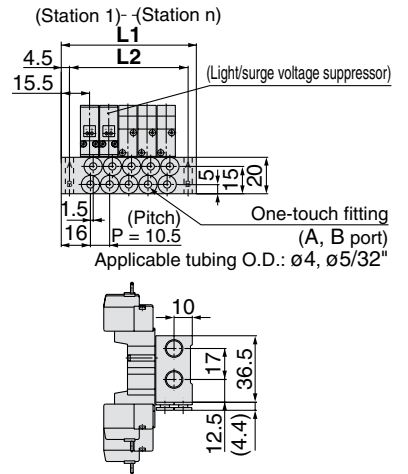

L plug connector (L)

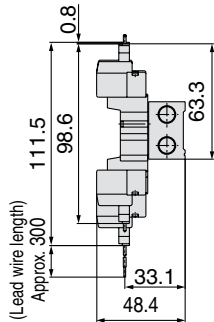

M plug connector (M)

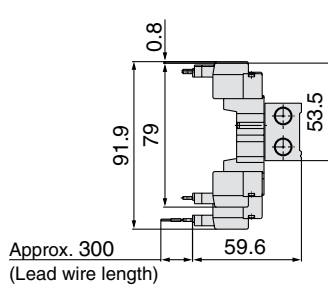

M8 connector (WO)

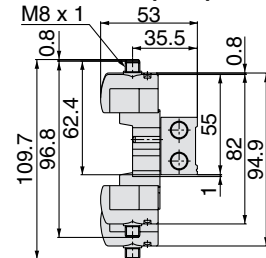

Refer to back page 11 for dimensions with connector cable.

Type S32 Manifold: Side Ported (Single solenoid coil is on same side as the A, B port.) /SS5YJ3-S32- Stations -M5, $C4$ $N3$ □ -Q

For M5

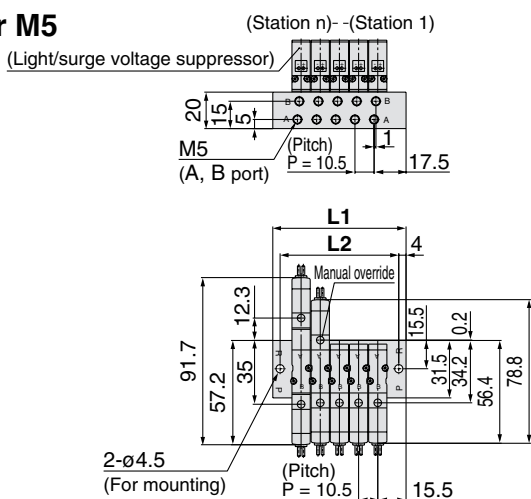

For $C4$ $N3$ □ (Built-in one-touch fitting)

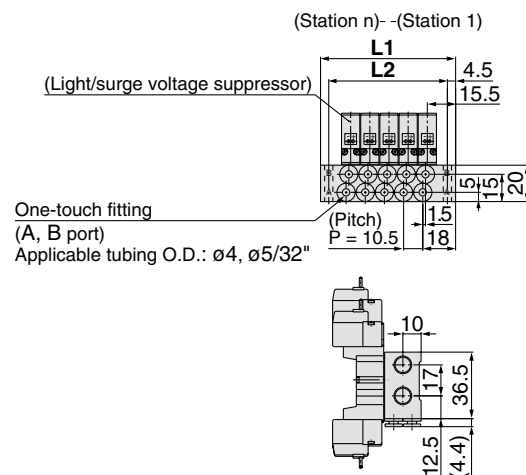

SS5YJ3-32, S32- Stations -M5-Q

Station n	Station 2	3	4	5	6	7	8	9	10	11	12	13	14	15	16	17	18	19	Station 20
L1	41.5	52	62.5	73	83.5	94	104.5	115	125.5	136	146.5	157	167.5	178	188.5	199	209.5	220	230.5
L2	33.5	44	54.5	65	75.5	86	96.5	107	117.5	128	138.5	149	159.5	170	180.5	191	201.5	212	222.5

SS5YJ3-32, S32- Stations -C4-Q

Station n	Station 2	3	4	5	6	7	8	9	10	11	12	13	14	15	16	17	18	19	Station 20
L1	42.5	53	63.5	74	84.5	95	105.5	116	126.5	137	147.5	158	168.5	179	189.5	200	210.5	221	231.5
L2	33.5	44	54.5	65	75.5	86	96.5	107	117.5	128	138.5	149	159.5	170	180.5	191	201.5	212	222.5

Series SYJ3000

Type 41 Manifold: Side Ported/SS5YJ3-41- Stations -M5, C4 N3 □ -Q

Grommet (G) For M5

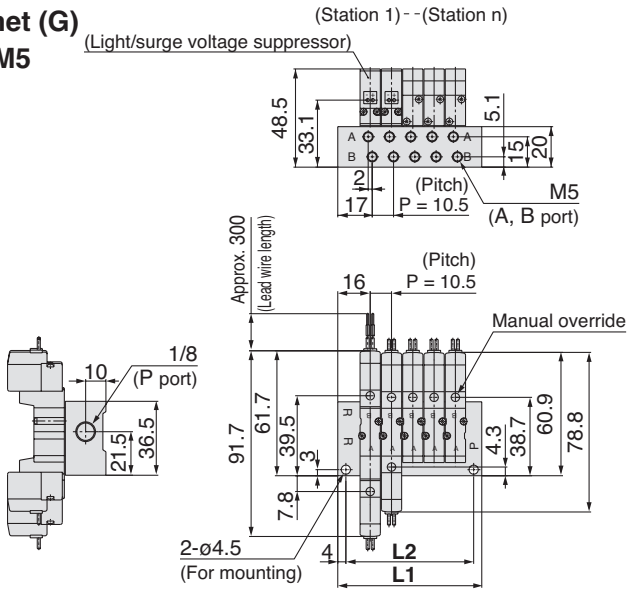

For C4 N3 □ (Built-in one-touch fitting)

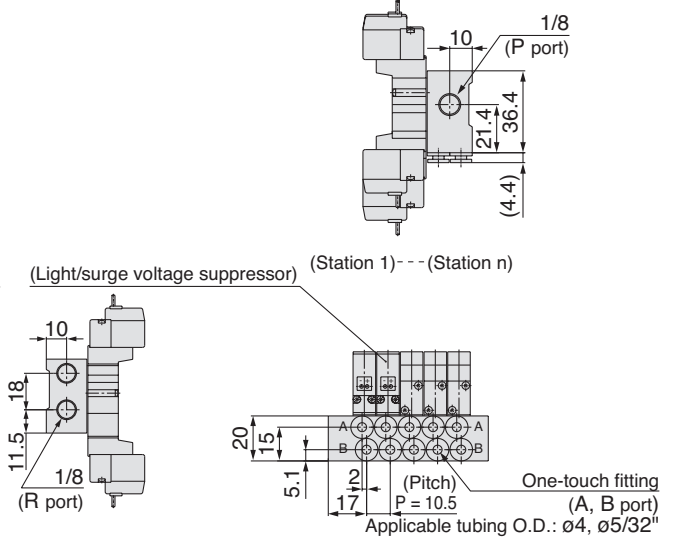

L plug connector (L)

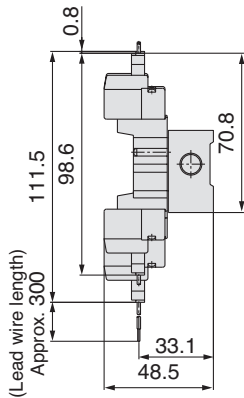

M plug connector (M)

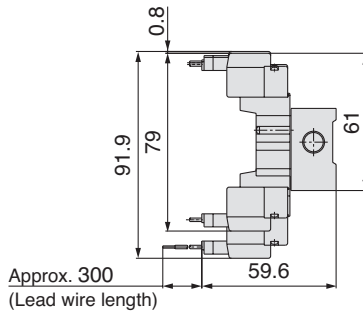

M8 connector (WO)

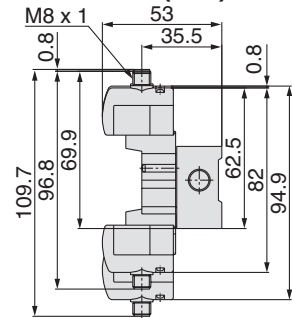

Refer to back page 11 for dimensions with connector cable.

Type S41 Manifold: Side Ported (Single solenoid coil is on same side as the A,B port) /SS5YJ3-S41- Stations -M5, C4 N3 □ -Q

For M5

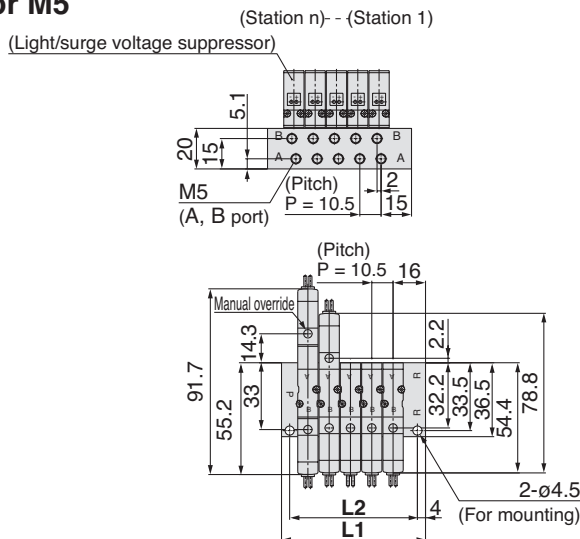

For C4 N3 □ (Built-in one-touch fitting)

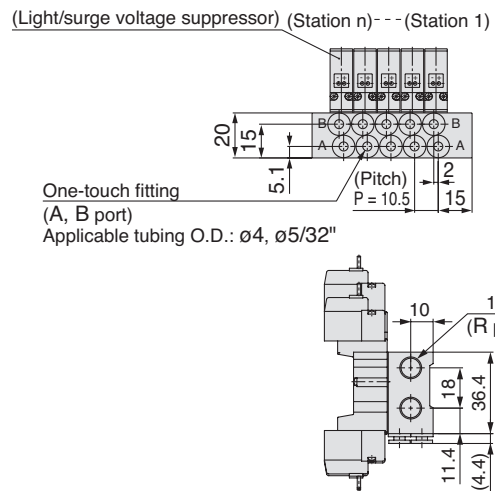

Station n	Station 2	3	4	5	6	7	8	9	10	11	12	13	14	15	16	17	18	19	Station 20
L1	39.5	50	60.5	71	81.5	92	102.5	113	123.5	134	144.5	155	165.5	176	186.5	197	207.5	218	228.5
L2	31.5	42	52.5	63	73.5	84	94.5	105	115.5	126	136.5	147	157.5	168	178.5	189	199.5	210	220.5

Type 46 Manifold: Side Ported/SS5YJ3-46- Stations -M5, C4 N3 □-Q

Grommet (G) For M5

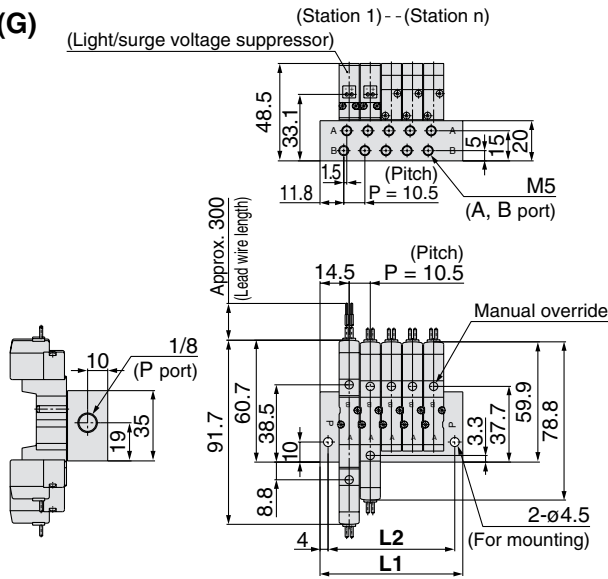

For C4 N3 □ (Built-in one-touch fitting)

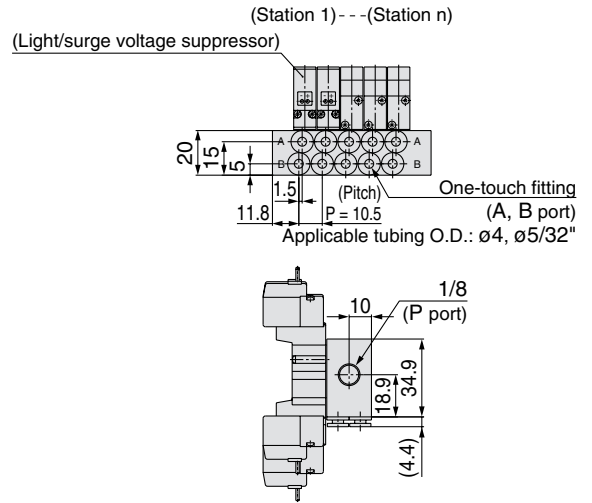

L plug connector (L)

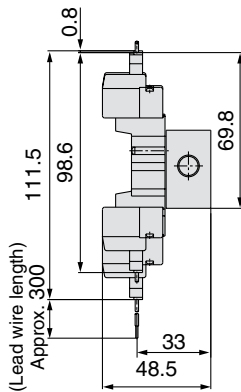

M plug connector (M)

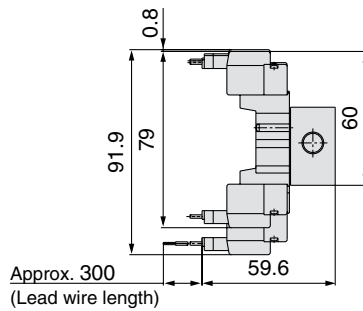

M8 connector (WO)

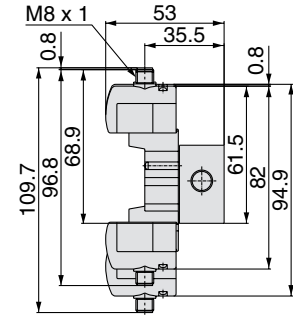

Refer to back page 11 for dimensions with connector cable.

Type S46 Manifold: Side Ported (Single solenoid coil is on same side as the A, B port.) /SS5YJ3-S46- Stations -M5, C4 N3 □-Q

For M5

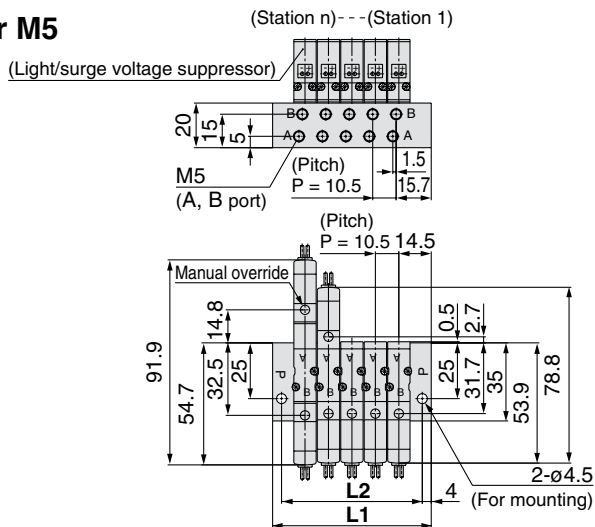

For C4 N3 □ (Built-in one-touch fitting)

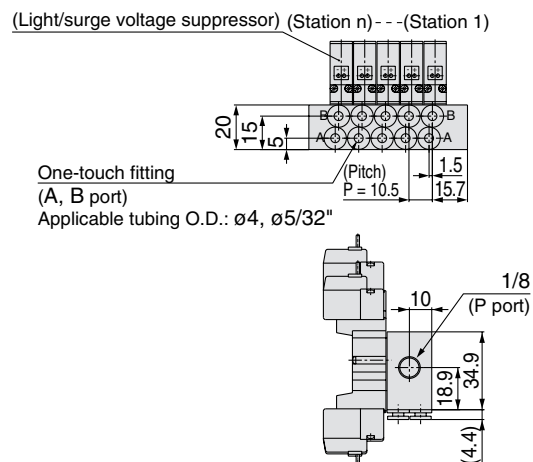

Station n	Station 2	3	4	5	6	7	8	9	10	11	12	13	14	15	16	17	18	19	Station 20
L1	39.5	50	60.5	71	81.5	92	102.5	113	123.5	134	144.5	155	165.5	176	186.5	197	207.5	218	228.5
L2	31.5	42	52.5	63	73.5	84	94.5	105	115.5	126	136.5	147	157.5	168	178.5	189	199.5	210	220.5

Series SYJ3000

Flat Ribbon Cable Manifold

SS5YJ3-21P- Stations -00□-Q

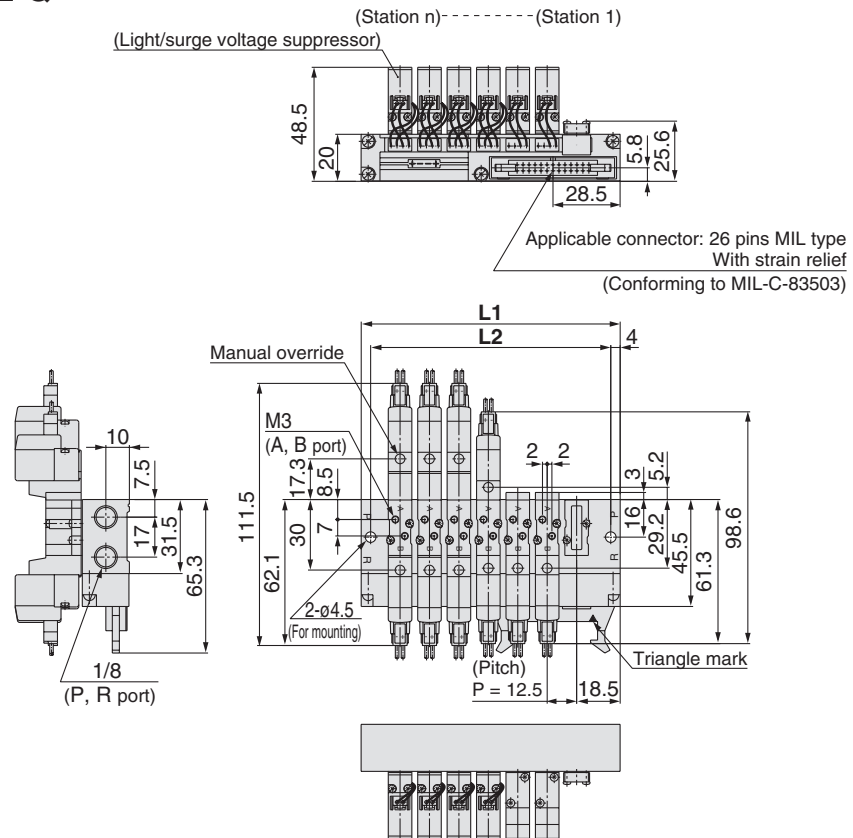

SS5YJ3-32P- Stations -M5, C4 N3 □-Q For M5

For C4 N3 □ (Built-in one-touch fitting)

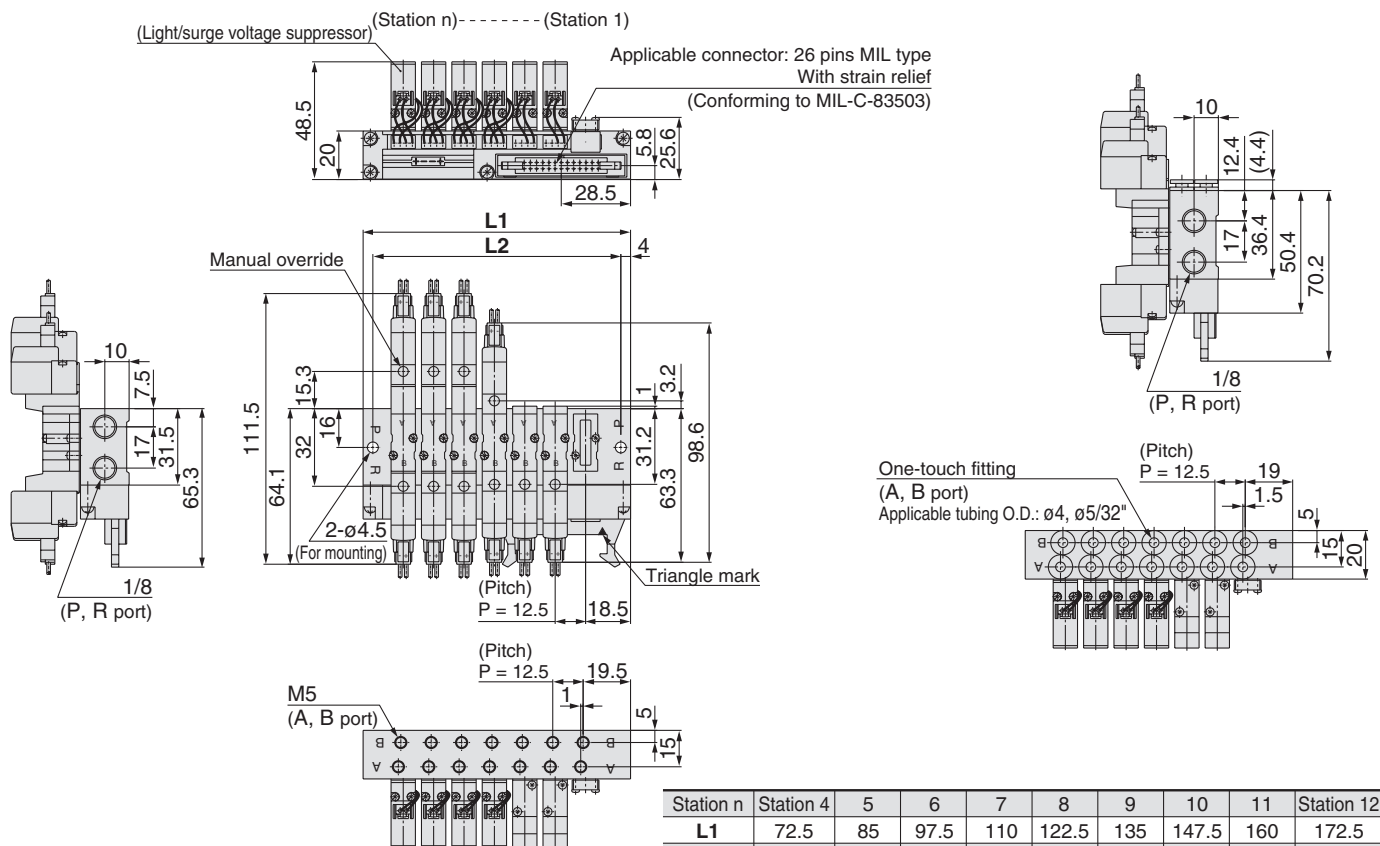

Station n	Station 4	5	6	7	8	9	10	11	Station 12
L1	72.5	85	97.5	110	122.5	135	147.5	160	172.5
L2	64.5	77	89.5	102	114.5	127	139.5	152	164.5

Flow Characteristics/Weight

Valve model	Type of actuation	Port size		Flow characteristics <small>Note 1)</small>								Weight (g) <small>Note 2, 3)</small>					
		1, 5, 3 (P, EA, EB)	4, 2 (A, B)	1→4/2 (P→A/B)				4/2→5/3 (A/B→EA/EB)				Grommet	L/M plug connector	DIN terminal	M8 connector		
				C [dm ³ /(s·bar)]	b	Cv	Q _l [l/min(ANR)]*	C [dm ³ /(s·bar)]	b	Cv	Q _l [l/min(ANR)]*						
Body ported	SYJ5□20-□-M5	2 position	Single	M5	M5 x 0.8	0.47	0.41	0.13	129	0.47	0.41	0.13	129	46	47	68	51
			Double														
		3 position	Closed center			0.49	0.44	0.13	137	0.44	0.40	0.12	120	75	77	119	85
			Exhaust center														
			Pressure center														
	SYJ5□20-□-C4	2 position	Single	M5	C4 (One-touch fitting for ø4)	0.69	0.39	0.18	186	0.44	0.39	0.12	119	53	54	75	58
			Double														
		3 position	Closed center			0.69	0.40	0.19	188	0.43	0.40	0.12	117	82	84	126	72
			Exhaust center														
			Pressure center														
SYJ5□20-□-C6	2 position	Single	M5	C6 (One-touch fitting for ø6)	0.70	0.36	0.19	185	0.47	0.40	0.12	128	53	54	75	58	
		Double															71
	3 position	Closed center			0.72	0.37	0.19	192	0.44	0.34	0.12	115	82	84	126	92	
		Exhaust center															
		Pressure center															
Base mounted	SYJ5□40-□-01	2 position	Single	1/8	1/8	0.79	0.21	0.19	190	0.83	0.32	0.21	214	80 (49)	81 (47)	102 (68)	51
			Double														
		3 position	Closed center			0.80	0.28	0.18	201	0.86	0.34	0.20	224	109 (75)	111 (77)	153 (119)	85
			Exhaust center														
			Pressure center														

Note 1) []: denotes the normal position. Exhaust center: 4/2 → 5/3, Pressure center: 1 → 4/2
 Note 2) (): Without sub-plate.
 Note 3) For DC voltages. For AC voltages add 3 g to the weight of the single solenoid and 6 g to the weight of the double solenoid and 3 position types.
 * These values have been calculated according to ISO6358 and represent the flow rate measured in standard conditions at an upstream of 0.6MPa (relative pressure) and a differential pressure of 0.1MPa.

Cylinder Speed Chart

Use as a guide for selection.
 Please confirm the actual conditions with SMC Sizing Program.

Body Ported

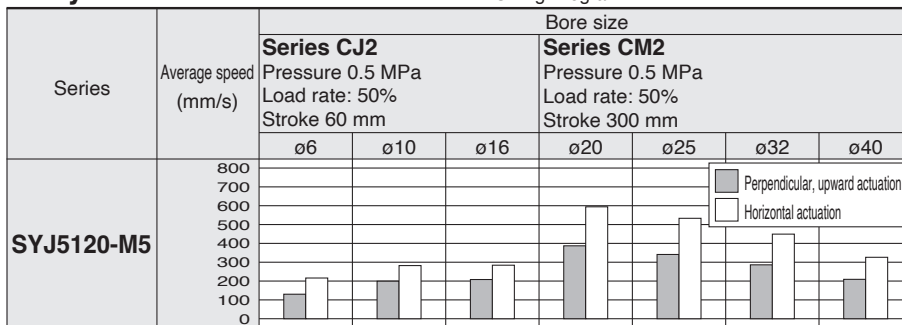

Base Mounted

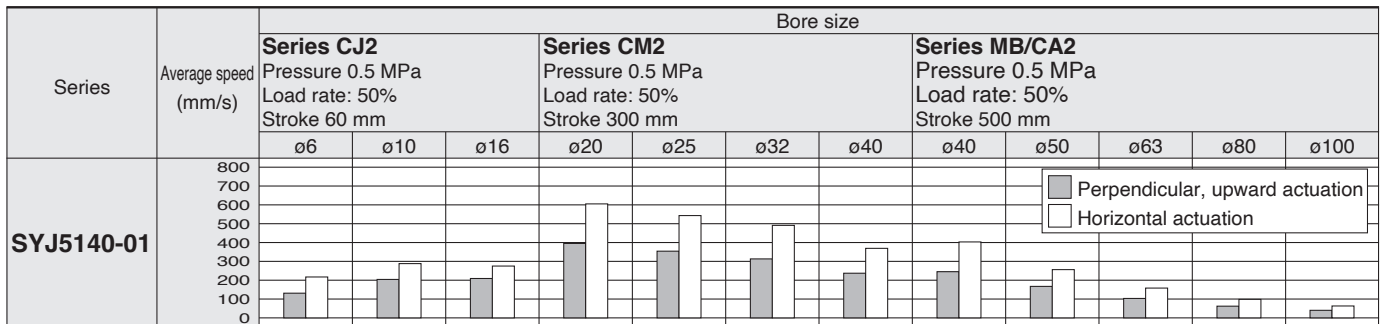

* Cylinder is in extending. Speed controller is meter-out, which is directly connected with cylinder and its needle is fully opened.
 * Average speed of cylinder is obtained by dividing the full stroke time by the stroke.
 * Load factor: ((Load weight x 9.8) / Theoretical force) x 100%

Conditions

	Body ported	Series CJ2	Series CM2	Series MB/CA2
SYJ5120-M5	Tubing bore x Length	ø4 x 1 m	ø6 x 1 m	ø8 x 1 m
	Speed controller	AS1301F-04	AS3301F-06	AS3301F-08
	Silencer	AN120-M5		

	Base mounted	Series CJ2	Series CM2	Series MB/CA2
SYJ5140-01	Tubing bore x Length	ø4 x 1 m	ø6 x 1 m	
	Speed controller	AS2301F-04	AS3001F-06	
	Silencer	AN101-01		

How to Order

Type of actuation

1	2 position single solenoid
2	2 position double solenoid
3	3 position closed center
4	3 position exhaust center
5	3 position pressure center

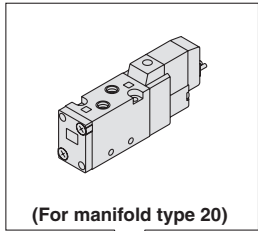

Light/surge voltage suppressor

Electrical entry for G, H, L, M, W

-	Without light/surge voltage suppressor
S	With surge voltage suppressor
Z	With light/surge voltage suppressor
R	With surge voltage suppressor (Non-polar type)
U	With light/surge voltage suppressor (Non-polar type)

* Power saving circuit is only available in the "Z" type.

Electrical entry for D

-	Without light/surge voltage suppressor
S	With surge voltage suppressor (Non-polar type)
Z	With light/surge voltage suppressor (Non-polar type)

* DOZ is not available.
* For AC voltage valves there is no "S" option. It is already built-in to the rectifier circuit.

Rated voltage

DC		AC (50/60 Hz)	
5	24 VDC	1	100 VAC
6	12 VDC	2	200 VAC
V	6 VDC	3	110 VAC [115 VAC]
S	5 VDC	4	220 VAC [230 VAC]
R	3 VDC		

* DC specifications of type D and DO is only available with 12 and 24 VDC.

* AC specification is only available with D, DO type.

A, B port size

M5	M5
C4	One-touch fitting for Ø4
C6	One-touch fitting for Ø6
N3	One-touch fitting for Ø5/32"
N7	One-touch fitting for Ø1/4"

Bracket

-: Without bracket
F: With bracket

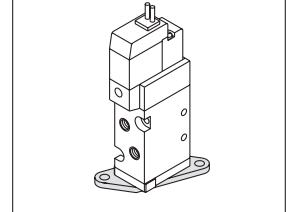

Note) The mounting bracket is supplied unattached.

Body ported

SYJ5 1 2 0 [] 5 L [] [] M5 [] Q

Base mounted

SYJ5 2 4 0 [] 5 L [] [] [] [] Q

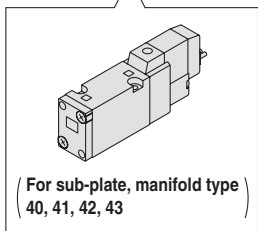

Body option

0: Pilot valve individual exhaust for the pilot valve

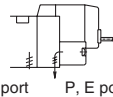

3: Common exhaust type for main and pilot valve

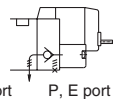

Coil specifications

-	Standard
T	With power saving circuit <24 V, 12 VDC only>

* Power saving circuit is not available in the case of D, DO or W□ type.

Manual override

-: Non-locking push type

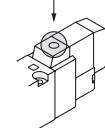

D: Push-turn locking slotted type

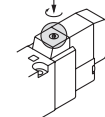

E: Push-turn locking lever type

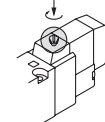

Thread type

-	Rc
F	G
N	NPT
T	NPTF

Port size

Nil: Without sub-plate

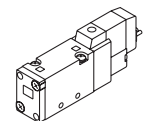

(With gasket and screws)

01: 1/8 With sub-plate

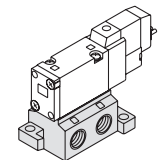

Electrical entry

24, 12, 6, 5, 3 VDC				24, 12 VDC 100, 110, 200, 220 VAC	24, 12, 6, 5, 3 VDC
Grommet	L plug connector	M plug connector		DIN terminal	M8 connector*
G: Lead wire length 300 mm	L: With lead wire (Length 300 mm)	M: With lead wire (Length 300 mm)	MN: Without lead wire	D: With connector	WO: Without connector cable
H: Lead wire length 600 mm	LN: Without lead wire	LO: Without connector	MO: Without connector	DO: Without connector	W□: With connector cable (Note 1)

* LN, MN type: with 2 sockets.
* DIN terminal type "Y" which conforms to EN-175301-803C (former DIN43650C) is also available. For details, refer to page 79.
* For connector cable of M8 connector, refer to back page 10.
* Connector M8 type "WA" conforming to IEC 60947-5-2 standard, is also available. For details, see page 80.

Note 1) Enter the cable length symbols in □.
Please be sure to fill in the blank referring to back page 10.

Construction

2 position single

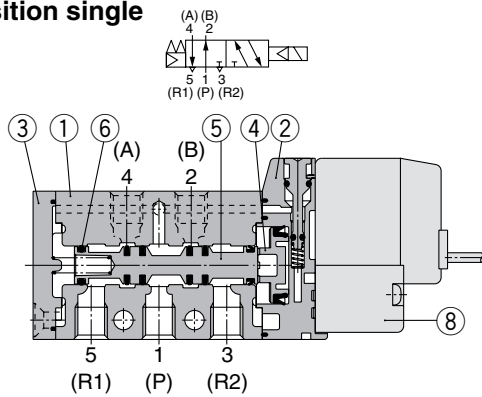

2 position double

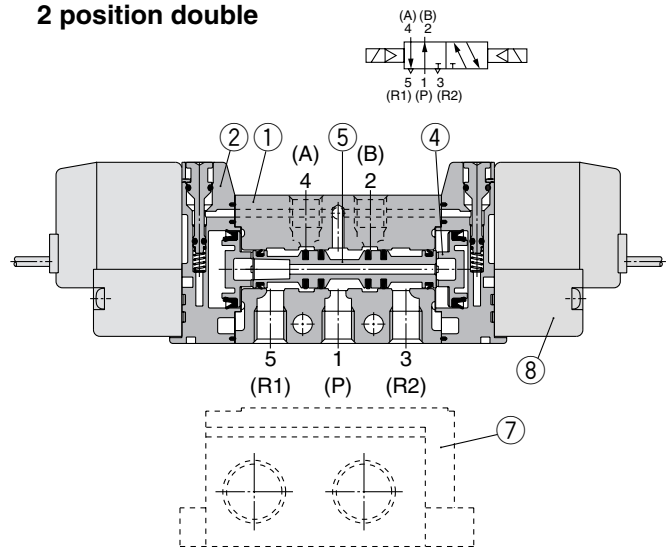

3 position closed center/exhaust center/pressure center

3 position closed center

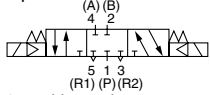

3 position exhaust center

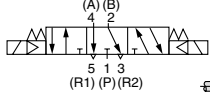

3 position pressure center

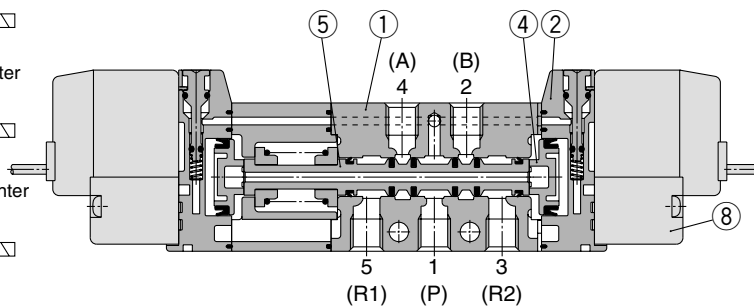
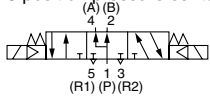

(This figure shows a closed center type.)

Component Parts

No.	Description	Material	Note
1	Body	Aluminum die-casted	White
2	Piston plate	Resin	White
3	End cover	Resin	White
4	Piston	Resin	—
5	Spool valve assembly	Aluminum, H-NBR	—
6	Spool spring	Stainless steel	—

Replacement Parts

No.	Description	No.	Note
7	Sub-plate	SYJ5000-22-1-Q	Aluminum die-casted
8	Pilot valve	V111(T)-□□□	
—	Bracket assembly	SYJ5000-13-3A	

Series SYJ5000

How to Order Pilot Valve Assembly

V111 - 5 G

Coil specifications

-	Standard
T	With power saving circuit (24, 12 VDC only)

* Power saving circuit is not available in the case of W type.

Rated voltage

5	24 VDC
6	12 VDC
V	6 VDC
S	5 VDC
R	3 VDC

Light/surge voltage suppressor

-	Without light/surge voltage suppressor
S	With surge voltage suppressor
Z	With light/surge voltage suppressor
R	With surge voltage suppressor (Non-polar type)
U	With light/surge voltage suppressor (Non-polar type)

* Power saving circuit is only available in the "Z" type.

Electrical entry

G	Grommet, 300 mm lead wire
H	Grommet, 600 mm lead wire
L	L plug connector
LN	With lead wire
LO	Without lead wire
M	M plug connector
MN	With lead wire
MO	Without lead wire
WO	M8 connector
W <input type="checkbox"/>	Without connector cable
	With connector cable ^{Note 1)}

* For connector cable of M8 connector, refer to back page 10.

Note 1) Enter the cable length symbols in . Please be sure to fill in the blank referring to back page 10.

V115 - 5 D

Rated voltage

5	24 VDC
6	12 VDC

* DC specifications of type D and DO is only available with 12 and 24 VDC.

* Power saving circuit is not available in the case of D or DO type.

Light/surge voltage suppressor

-	Without light/surge voltage suppressor
S	With surge voltage suppressor (Non-polar type)
Z	With light/surge voltage suppressor (Non-polar type)

* DOZ is not available.

Electrical entry

D	DIN terminal	With connector
DO		Without connector

Note) Do not replace V111 (G, H, L, M, W) to V115 (DIN terminal) and vice versa when replacing pilot valve assembly only.

How to Order Connector Assembly for L/M Plug Connector

For DC : SY100-30-4A-

Without lead wire : SY100-30-A
(with connector and 2 of sockets only)

Lead wire length

-	300 mm
6	600 mm
10	1000 mm
15	1500 mm
20	2000 mm
25	2500 mm
30	3000 mm
50	5000 mm

How to Order M8 Connector Cable

V100-49-1-

Cable length

1	300 mm
2	500 mm
3	1000 mm
4	2000 mm
7	5000 mm

2 Position Single

Grommet (G), (H): SYJ5120-□^G_H□□-M5-Q

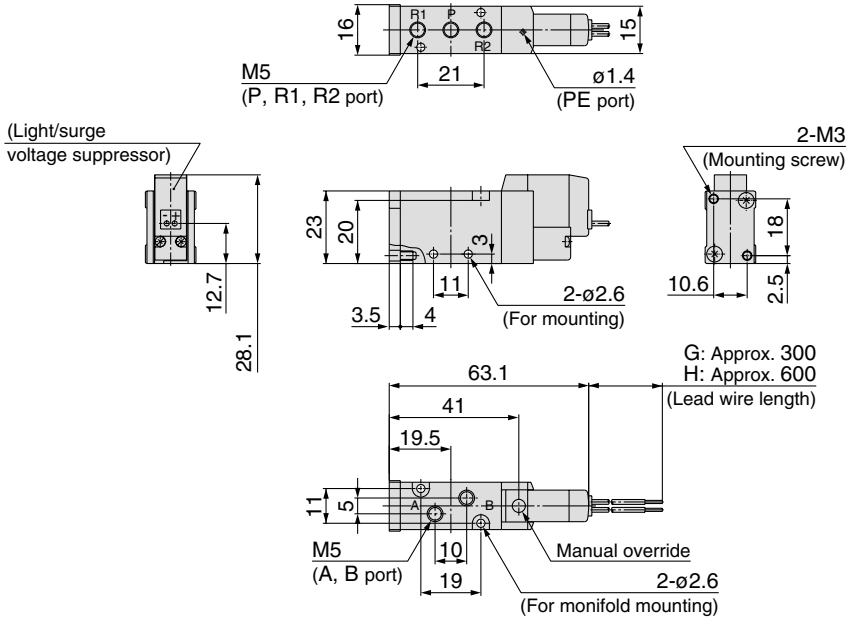

With bracket
SYJ5120-□^G_H□□-M5-F-Q

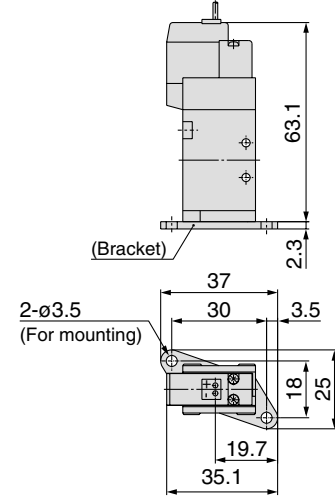

Built-in one-touch fitting:
SYJ5120-□^G_H□□-C4, N3
C6, N7 (-F)-Q

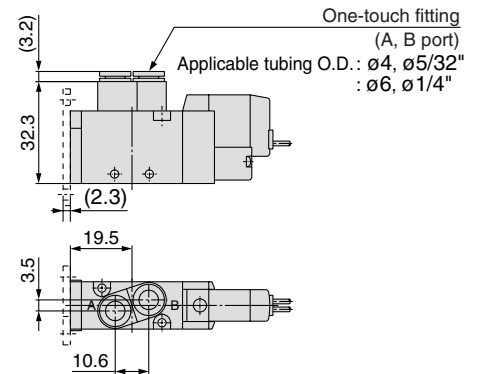

L plug connector (L): SYJ5120-□L□□-M5(-F)-Q

M plug connector (M): SYJ5120-□M□□-M5(-F)-Q

DIN terminal (D): SYJ5120-□D□□-M5(-F)-Q

M8 connector (WO): SYJ5120-□WO□□-M5(-F)-Q

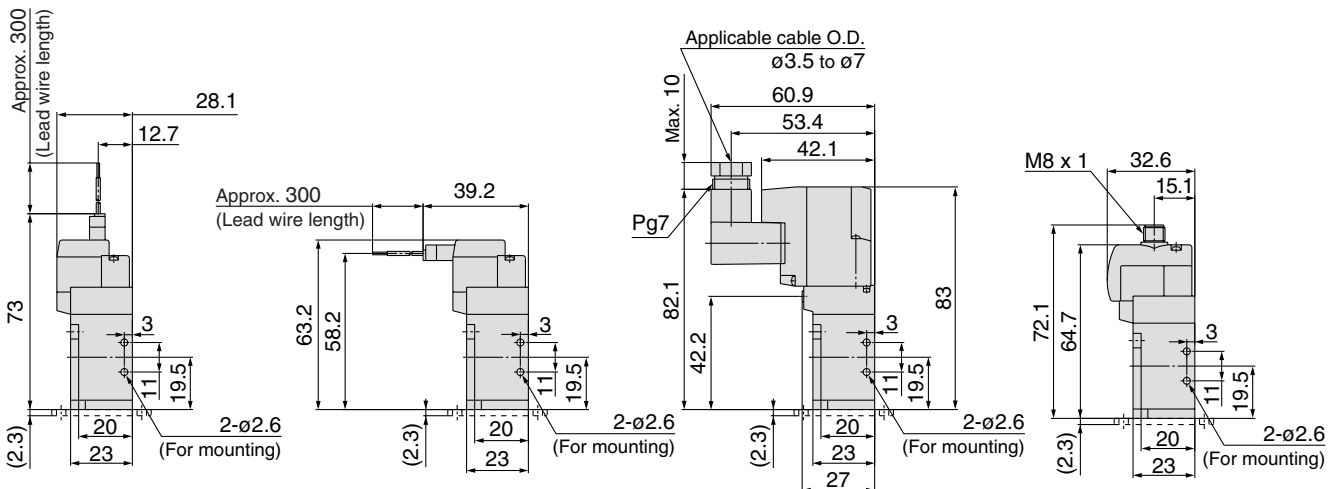

Refer to back page 11 for dimensions with connector cable.

Series SYJ5000

2 Position Double

Grommet (G), (H): SYJ5220-□^G_H□□-M5-Q

Built-in one-touch fitting:

SYJ5220-□^G_H□□-^{C4, N3}_{C6, N7}-Q

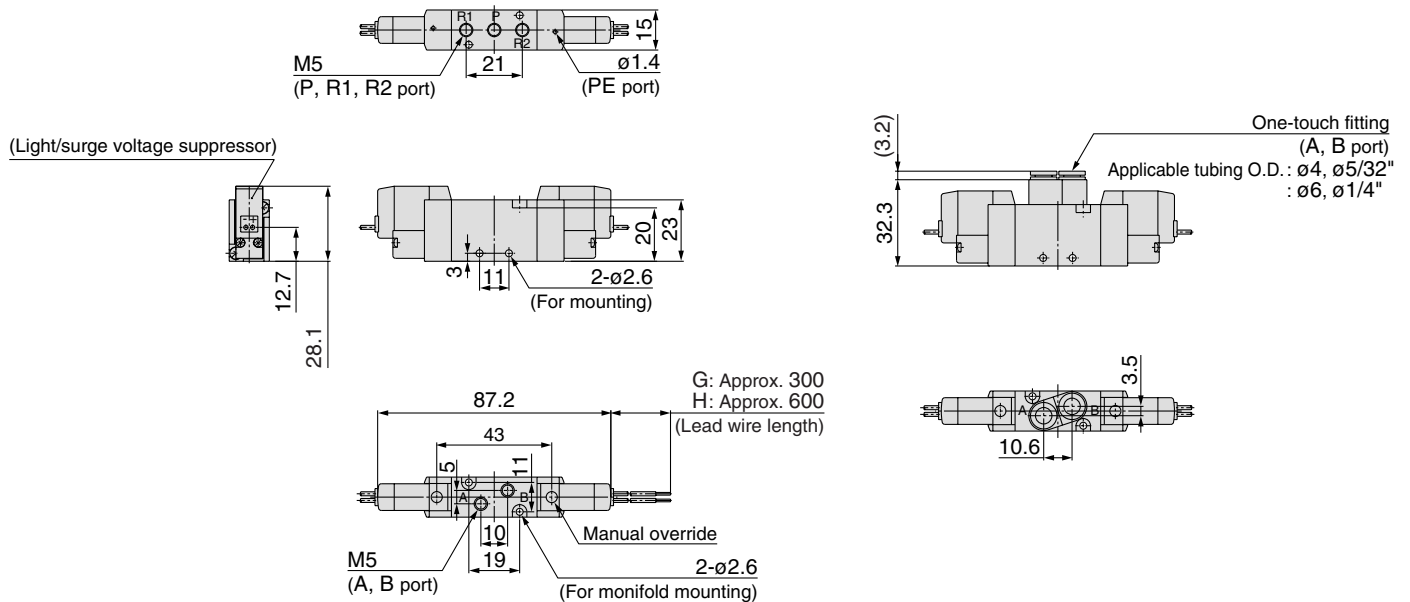

L plug connector (L): SYJ5220-□L□□-M5-Q

M plug connector (M): SYJ5220-□M□□-M5-Q

DIN terminal (D): SYJ5220-□D□□-M5-Q

M8 connector (WO): SYJ5220-□WO□□-M5-Q

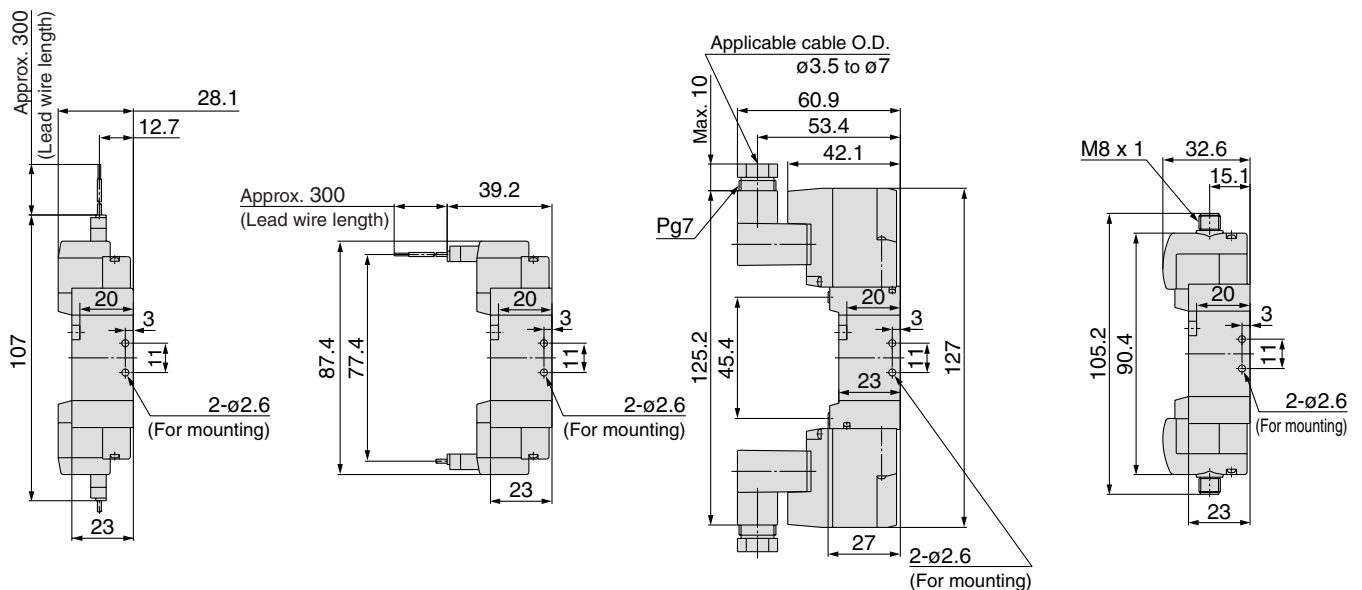

Refer to back page 11 for dimensions with connector cable.

3 Position Closed Center/Exhaust Center/Pressure Center

Grommet (G), (H): SYJ5³/₄20-□^G□□-M5-Q

Built-in one-touch fitting:

SYJ5³/₄20-□^H□□-C4, N3-C6, N7-Q

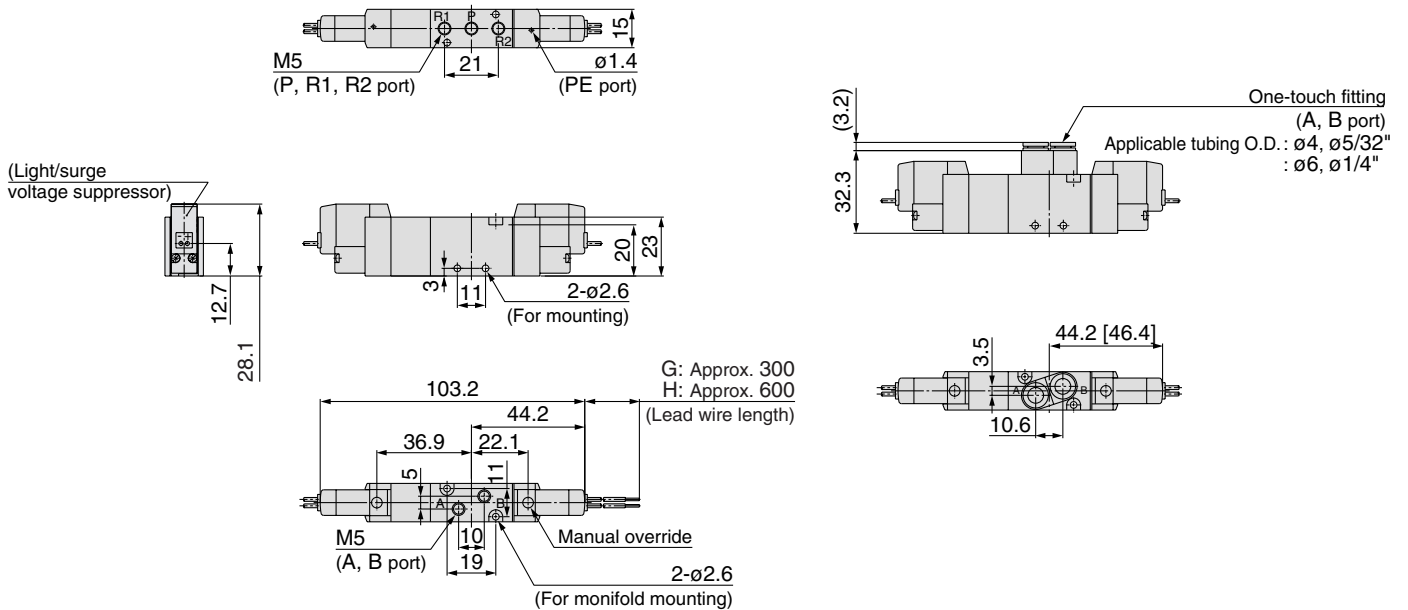

L plug connector (L):
SYJ5³/₄20-□L□□-M5-Q

M plug connector (M):
SYJ5³/₄20-□M□□-M5-Q

DIN terminal (D):
SYJ5³/₄20-□D□□-M5-Q

M8 connector (WO):
SYJ5³/₄20-□WO□□-M5-Q

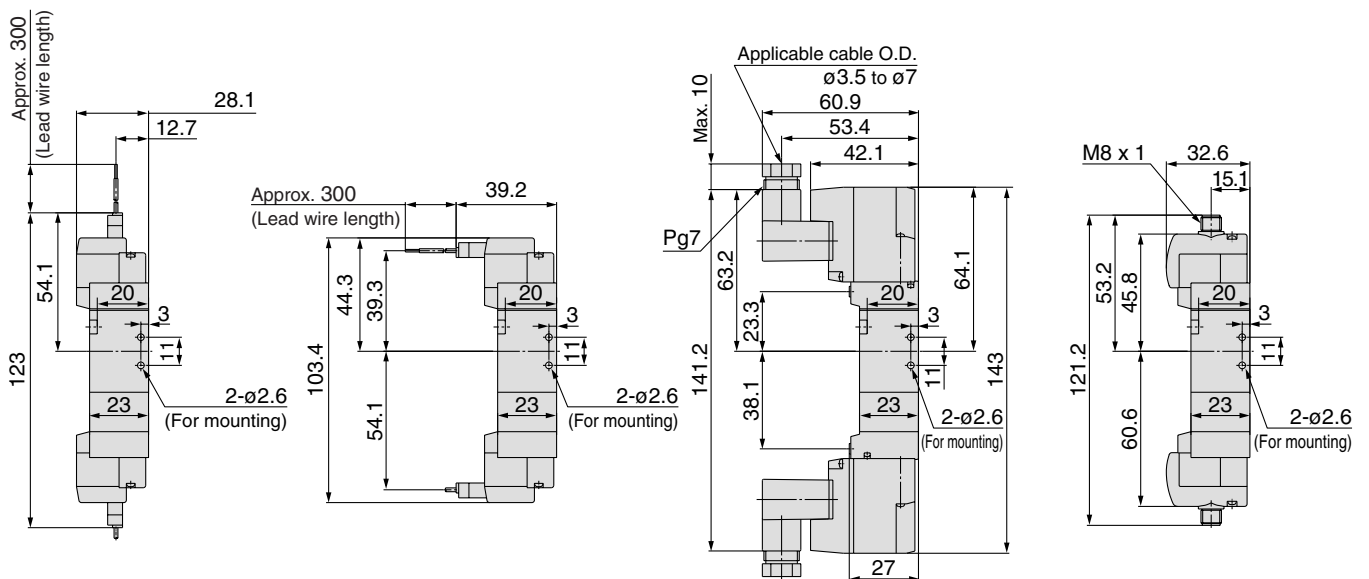

Refer to back page 11 for dimensions with connector cable.

Series SYJ5000

2 Position Single

Grommet (G), (H): SYJ5140-□_G□□□-01□-Q

Built-in speed controller:
SYJ5150-□_G□□□-01□-Q

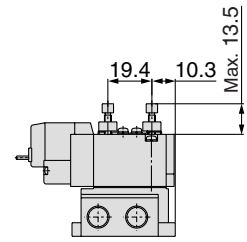
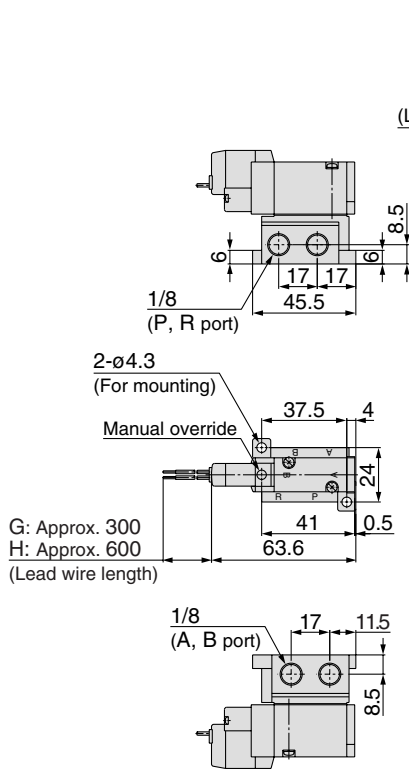

With interface regulator

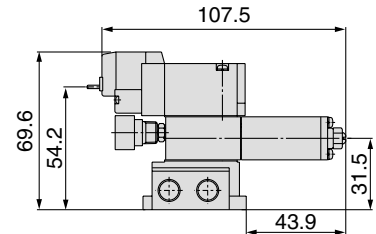

L plug connector (L):
SYJ5140-□L□□-01□-Q

M plug connector (M):
SYJ5140-□M□□-01□-Q

DIN terminal (D):
SYJ5140-□D□□-01□-Q

M8 connector (WO):
SYJ5140-□WO□□-01□-Q

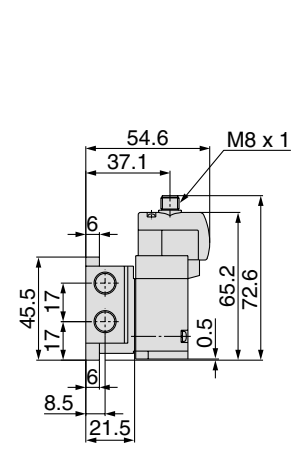
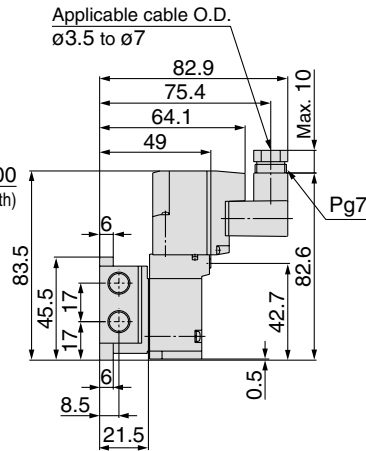
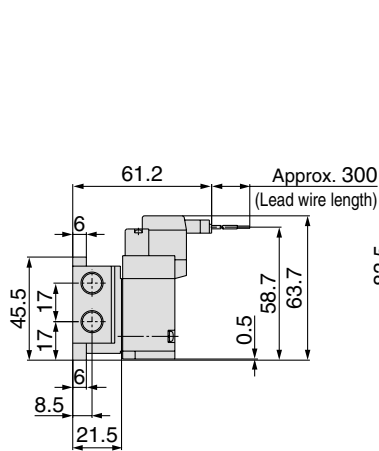
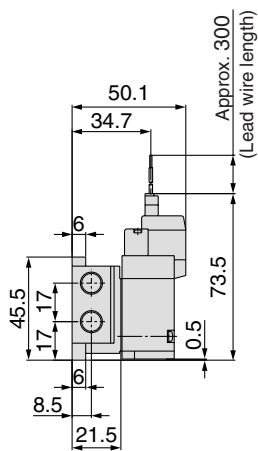

Refer to back page 11 for dimensions with connector cable.

2 Position Double

Grommet (G), (H): SYJ5240-□_G□□-01□-Q

Built-in speed controller:
SYJ5250-□_G□□-01□-Q

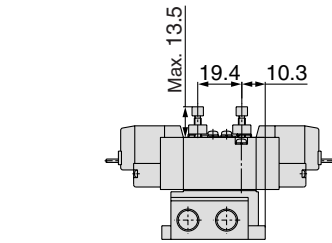
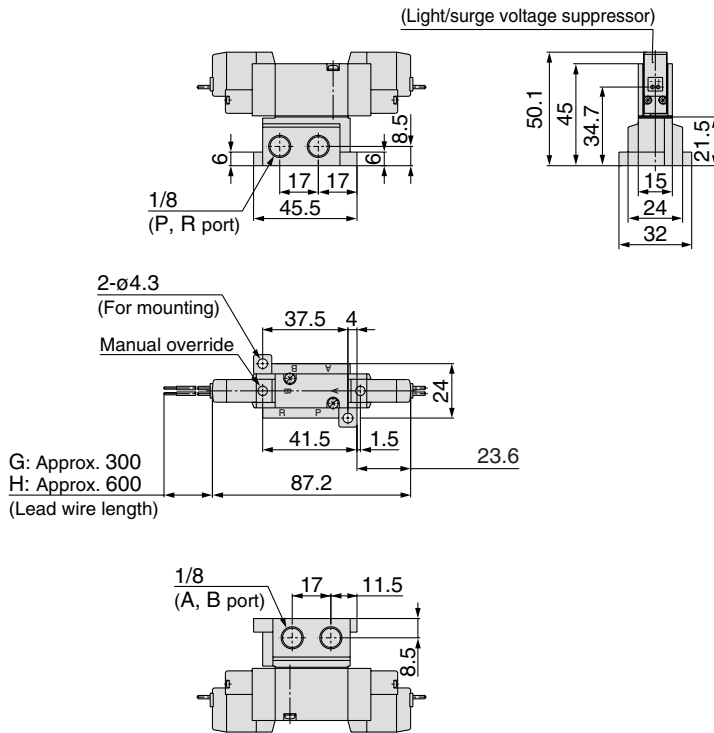

With interface regulator

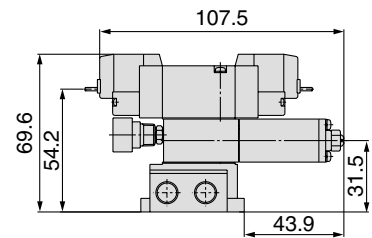

L plug connector (L):
SYJ5240-□L□□-01□-Q

M plug connector (M):
SYJ5240-□M□□-01□-Q

DIN terminal (D):
SYJ5240-□D□□-01□-Q

M8 connector (WO):
SYJ5240-□WO□□-01□-Q

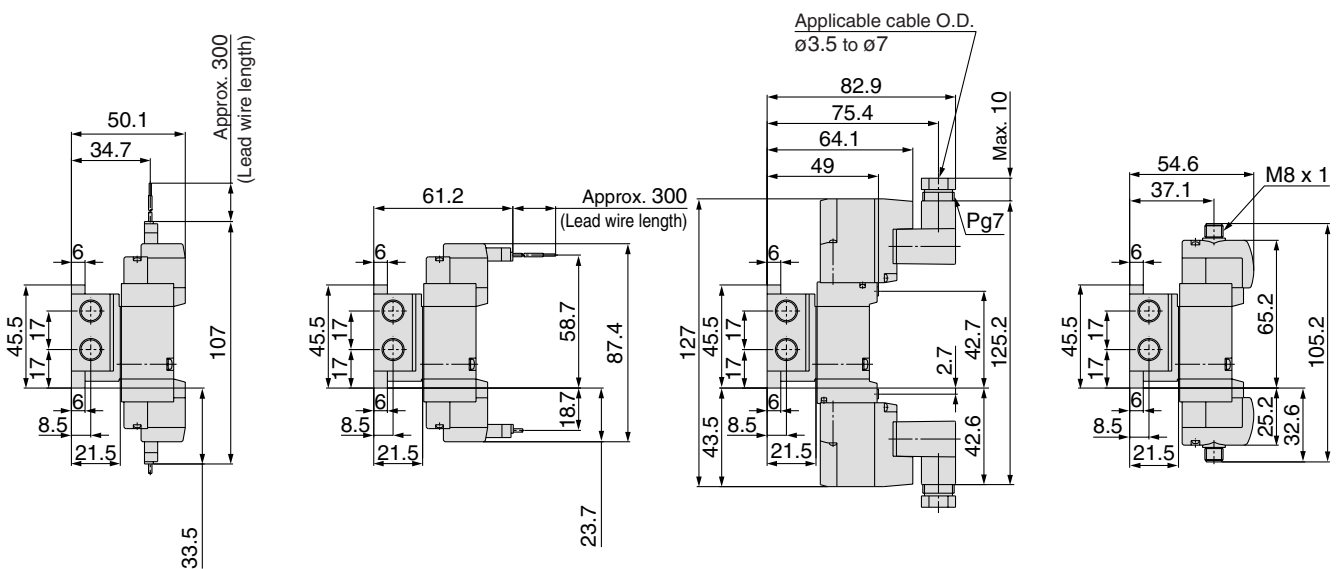

Refer to back page 11 for dimensions with connector cable.

Series SYJ5000

3 Position Closed Center/Exhaust Center/Pressure Center

Grommet (G), (H): SYJ5³₄40-□^G□□-01□-Q

Built-in speed controller:
SYJ5³₄50-□^G□□-01□-Q

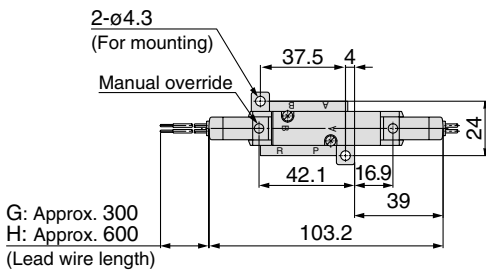
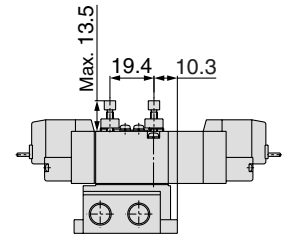
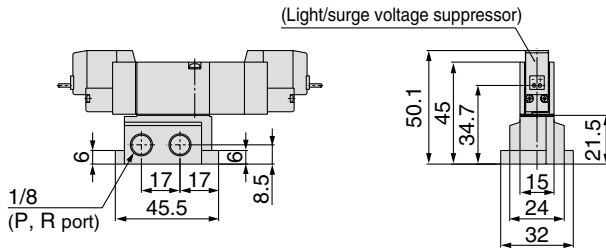

With interface regulator

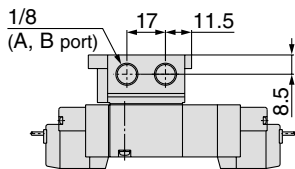
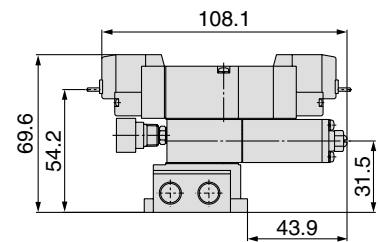

L plug connector (L):
SYJ5³₄40-□L□□-01□-Q

M plug connector (M):
SYJ5³₄40-□M□□-01□-Q

DIN terminal (D):
SYJ5³₄40-□D□□-01□-Q

M8 connector (WO):
SYJ5³₄40-□WO□□-01□-Q

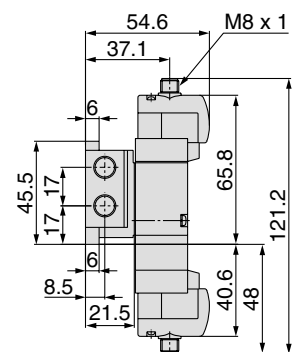
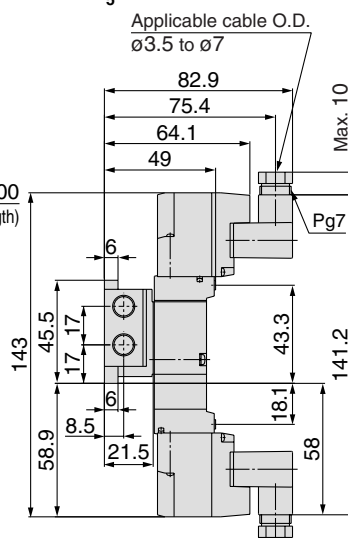
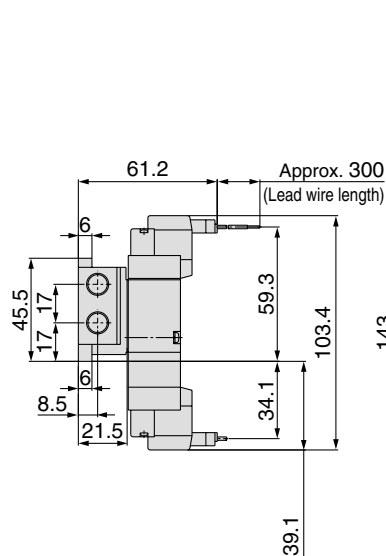
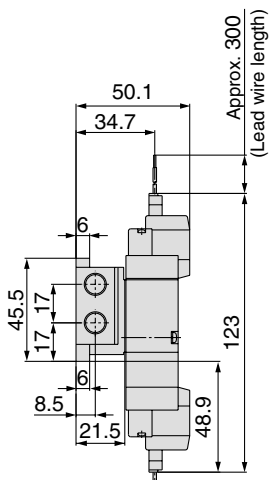

Refer to back page 11 for dimensions with connector cable.

Series SYJ5000 Manifold Specifications



Manifold Standard

Manifold Specifications



Model		Type 20	Type 40	Type 41	Type 42	Type 43
Manifold type		Single base/B mount				
P (SUP), R (EXH)		Common SUP, Common EXH				
Valve stations		2 to 20 stations				
A, B port Porting specifications	Location	Valve	Base	Base		
	Direction	Top	Bottom	Side		
Port size	P, R port	1/8			1/4	1/8
	A, B port	M5, C4 (One-touch fitting for ø4) C6 (One-touch fitting for ø6)	M5		1/8, C6 (One-touch fitting for ø6)	C4 (One-touch fitting for ø4)

Flow Characteristics

Manifold			Port size		Flow characteristics							
					1→4/2 (P→A/B)				4/2→5/3 (A/B→R)			
			1(P), 5/3(R) Port	2(B), 4(A) Port	C (dm ³ /s-bar)	b	Cv	Q _l (l/min)(ANR) [*]	C (dm ³ /s-bar)	b	Cv	Q _l (l/min)(ANR) [*]
Body ported for internal pilot	Type SS5YJ5-20	SYJ5□2□	1/8	M5	0.46	0.39	0.12	124	0.75	0.32	0.19	193
			1/8	C4	0.62	0.33	0.16	161	0.83	0.27	0.20	207
			1/8	C6	0.79	0.36	0.21	209	0.91	0.36	0.24	241
Base mounted for internal pilot	Type SS5YJ5-40	SYJ5□4□	1/8	M5	0.55	0.35	0.15	144	0.64	0.26	0.16	159
	Type SS5YJ5-41		1/8	M5	0.59	0.35	0.16	155	0.68	0.23	0.17	166
	Type SS5YJ5-42-01		1/4	1/8	0.74	0.22	0.18	179	0.82	0.31	0.21	210
	Type SS5YJ5-42-C6		1/4	C6	0.71	0.24	0.17	174	0.8	0.29	0.20	202
	Type SS5YJ5-43		1/8	C4	0.55	0.29	0.14	139	0.74	0.32	0.19	191



Note) Value at manifold base mounted, 2 position single operating

* These values have been calculated according to ISO6358 and represent the flow rate measured in standard conditions at an upstream of 0.6MPa (relative pressure) and a differential pressure of 0.1MPa.

How to Order Manifold (Example)

Instruct by specifying the valves and blanking plate assembly to be mounted on the manifold along with the manifold base model no.

Example: **SS5YJ5-20-03-Q** 1 pc. (Manifold base)

* **SYJ5120-5G-M5-Q** 2 pcs. (Valve)

* **SYJ5000-21-4A-Q** 1 pc. (Blanking plate assembly)

SS5YJ5-43-03-C4-Q 1 pc. (Manifold base)

* **SYJ5140-5LZ-Q** 1 pc. (Valve)

* **SYJ5240-5LZ-Q** 1 pc. (Valve)

* **SYJ5000-21-4A-Q** 1 pc. (Blanking plate assembly)

↳ The asterisk denotes the symbol for assembly. Prefix it to the part nos. of the solenoid valve, etc.

* Use manifold specification sheet.

Flat Ribbon Cable Manifold

• Multiple valve wiring is simplified through the use of the flat cable connector.

• **Clean appearance**

In the case of a flat ribbon cable type, each valve is wired on the print board of manifold base to allow the external wiring to be piped all together with 26 pins MIL connector.

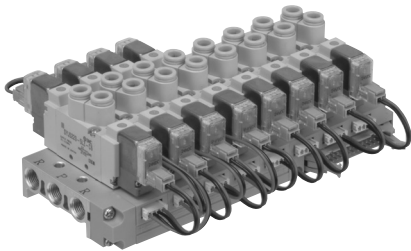

Flat Ribbon Cable Manifold Specifications

Model		Type 20	Type 41P	Type 43P
Manifold type		Single base/B mount		
P (SUP), R (EXH)		Common SUP, Common EXH		
Valve stations		3 to 12 stations		
A, B port	Location	Valve	Base	
Porting specifications	Direction	Top		
	P, R port	1/8		
Port size	A, B port	M5, C4 (One-touch fitting for ø4) C6 (One-touch fitting for ø6)	M5	C4 (One-touch fitting for ø4)
	Applicable flat ribbon cable connector	Socket: 26 pins MIL type with strain relief (MIL-C-83503)		
Internal wiring		In common between +COM and -COM (Z type: +COM only).		
Rated voltage		24, 12 VDC		

Note) The withstand voltage specification for the wiring unit section conforms to JIS C 0704, Grade 1 or its equivalent.

Flow Characteristics

Manifold			Port size		Flow characteristics							
					1→4/2 (P→A/B)				4/2→5/3 (A/B→R)			
			1(P), 5/3(R) Port	2(B), 4(A) Port	C [dm ³ /(s·bar)]	b	Cv	Q[l/min(ANR)]*	C [dm ³ /(s·bar)]	b	Cv	Q[l/min(ANR)]*
Body ported for internal pilot	Type SS5YJ5-20P	SYJ5□23	1/8	M5	0.46	0.39	0.12	124	0.75	0.32	0.19	193
			1/8	C4	0.62	0.33	0.16	161	0.83	0.27	0.20	207
			1/8	C6	0.79	0.36	0.21	209	0.91	0.36	0.24	241
Base mounted for internal pilot	Type SS5YJ5-41P	SYJ5□43	1/8	M5	0.59	0.35	0.16	155	0.68	0.23	0.17	166
	Type SS5YJ5-43P		1/8	C4	0.55	0.29	0.14	139	0.74	0.32	0.19	191

Note) Value at manifold base mounted, 2 position single operating
 * These values have been calculated according to ISO6358 and represent the flow rate measured in standard conditions at an upstream of 0.6MPa (relative pressure) and a differential pressure of 0.1MPa.

How to Order Manifold (Example)

Instruct by specifying the valves and blanking plate assembly to be mounted on the manifold along with the manifold base model no.

Example: **SS5YJ5-41P-07-C4-Q** 1 pc. (Manifold base)
 * **SYJ5143-5LOU-Q** 3 pcs. (Valve)
 * **SYJ5243-5LOU-Q** 3 pcs. (Valve)
 * **SYJ5000-21-8A-Q** 1 pc. (Blanking plate assembly)
 * **SY3000-37-28A-Q** 3 pcs. (Connector assembly)
 * **SY3000-37-29A-Q** 3 pcs. (Connector assembly)

↳ The asterisk denotes the symbol for assembly. Prefix it to the part nos. of the solenoid valve, etc.

* Use manifold specification sheet.

How to Order Valve

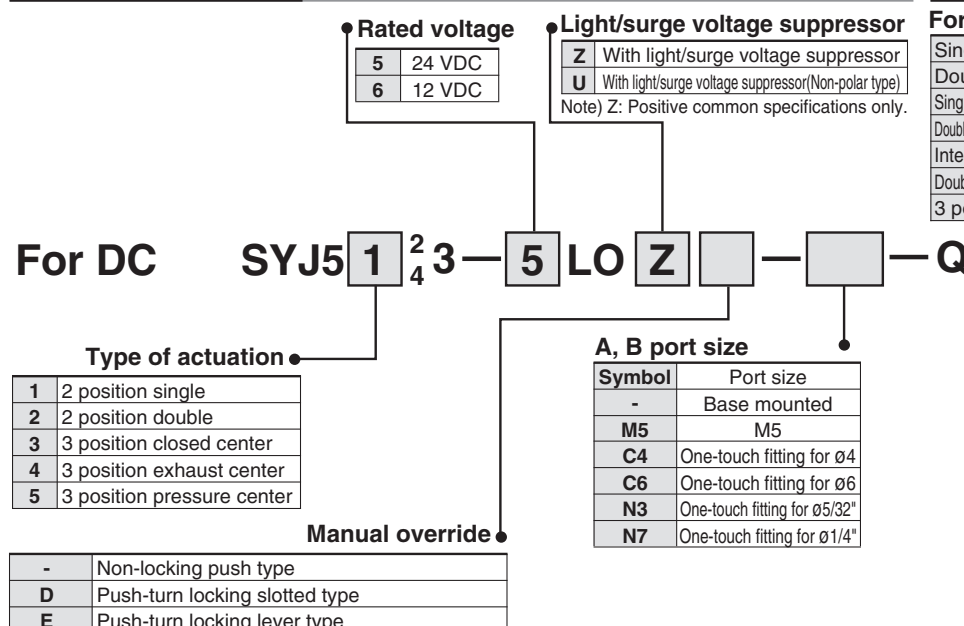

How to Order Connector Assembly

For 12, 24 VDC

Single solenoid	SY3000-37-28A
Double solenoid, 3 position type	SY3000-37-29A
Single solenoid, individual SUP, EXH spacer	SY3000-37-3A
Double solenoid, 3 position individual SUP/EXH spacer	SY3000-37-4A
Interface regulator for single solenoid	SY3000-37-3A
Double solenoid, 3 position interface regulator	SY3000-37-6A
3 port adaptor plate	SY3000-37-3A

Flat Ribbon Cable Connector

AXT100-FC26-¹/₂/₃

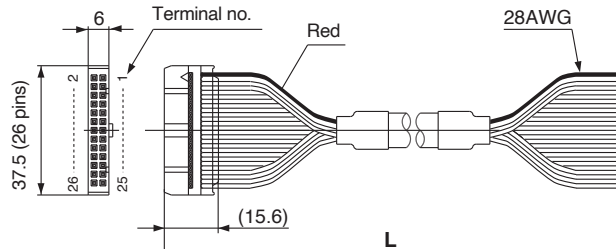

Flat ribbon cable connector

Cable length (L)	Assembly part no.
	26 pins
1.5 m	AXT100-FC26-1
3 m	AXT100-FC26-2
5 m	AXT100-FC26-3

- * When using a standard commercial connector, use a 26-pin type connector conforming to MIL-C-83503 with strain relief.
- * Cannot be used for movable wiring
- * Lengths other than the above are also available. Please contact SMC for details.

Connector Manufacturer's Example

- HIROSE ELECTRIC CO., LTD.
- 3M Japan Limited
- Fujitsu Limited
- Japan Aviation Electronics Industry, Limited
- J.S.T. Mfg. Co., Ltd.
- Oki Electric Cable Co., Ltd.

Specified Layout

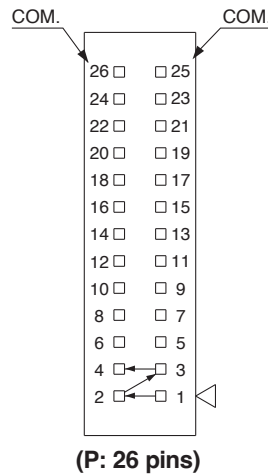

A mixture of single and double wiring can be specified on the manifold specification sheet. The maximum number of stations is determined according to the number of solenoids. The total number of solenoids should be 24 or less for P and PC. 1 solenoid is required for the 2-position single, and 2 solenoids for the 2-position double, and 3-position.

A mixture of single and double wiring can be specified on the manifold specification. The maximum number of stations is determined according to the number of solenoids. The total number of solenoids should be 24 or less for P, 18 or less for PG, and 8 or less for PH. 1 solenoid is required for the 2-position single, and 2 solenoids for the 2-position double, 3-position, and 4-position.

Common SUP/Common EXH



Note) For more than 8 stations, supply air to both sides of P port and exhaust air from both sides of R port.

Type 20 (5 Port/Body ported)

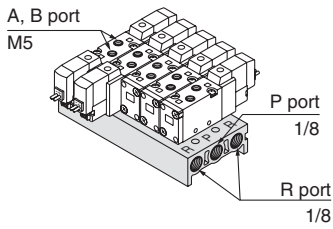

How to Order

SS5YJ5-20-05-□-Q

Number of stations

02	2 stations
:	:
20	20 stations

P, R port thread type

-	Rc
00F	G
00N	NPT
00T	NPTF

Applicable solenoid valve

SYJ5□20-□□□□-M5-C4-Q
SYJ5□23-□□□□-C4-Q

Applicable blanking plate assembly

SYJ5000-21-4A-Q

Applicable individual EXH spacer assembly

SYJ5000-17-1A-Q

Type 40 (5 Port/Base mounted)

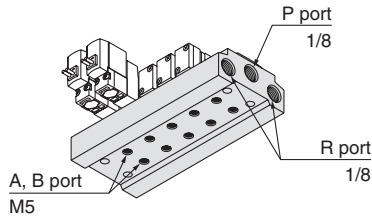

How to Order

SS5YJ5-40-05-M5-□-Q

Stations

02	2 stations
:	:
20	20 stations

P, R port thread type

-	Rc
F	G
N	NPT
T	NPTF

A, B port size

M5	M5
----	----

Applicable solenoid valve

SYJ5□40-□□□□-Q
SYJ5□43-□□□□-Q
SYJ5□50-□□□□-Q
SYJ5□53-□□□□-Q

Applicable blanking plate assembly

SYJ5000-21-1A-2-Q

Applicable individual EXH spacer assembly

SYJ5000-17-1A-2-Q

Applicable interface regulator

ARBYJ5000-00-P-Q

Type 41 (5 Port/Base mounted)

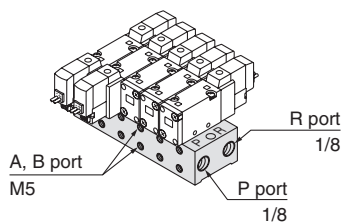

How to Order

SS5YJ5-41-05-M5-□-Q

Stations

02	2 stations
:	:
20	20 stations

P, R port thread type

-	Rc
F	G
N	NPT
T	NPTF

A, B port size

M5	M5
----	----

Applicable solenoid valve

SYJ5□40-□□□□-Q
SYJ5□43-□□□□-Q
SYJ5□50-□□□□-Q
SYJ5□53-□□□□-Q

Applicable blanking plate assembly

SYJ5000-21-1A-2-Q

Applicable individual EXH spacer assembly

SYJ5000-17-1A-2-Q

Applicable individual SUP spacer assembly

SYJ5000-16-2A-Q

Applicable interface regulator

ARBYJ5000-00-P-Q

Type 42 (5 Port/Base mounted)

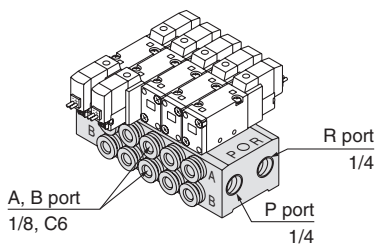

How to Order

SS5YJ5-42-05-C6-□-Q

Stations

02	2 stations
:	:
20	20 stations

Thread type

-	Rc
F	G
N	NPT
T	NPTF

A, B port size

01	1/8
C6	One-touch fitting for ø6
N7	One-touch fitting for ø1/4"

Applicable solenoid valve

SYJ5□40-□□□□-Q
SYJ5□43-□□□□-Q
SYJ5□50-□□□□-Q
SYJ5□53-□□□□-Q

Applicable blanking plate assembly

SYJ5000-21-1A-2-Q

Applicable individual EXH spacer assembly

SYJ5000-17-1A-2-Q

Applicable individual SUP spacer assembly

SYJ5000-16-2A-Q

Applicable interface regulator

ARBYJ5000-00-P-Q

Type 43 (5 Port/Base mounted)

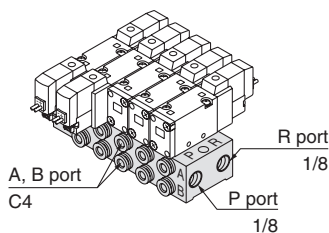

How to Order

SS5YJ5-43-05-C4-□-Q

Stations

02	2 stations
:	:
20	20 stations

P, R port thread type

-	Rc
F	G
N	NPT
T	NPTF

A, B port size

C4	One-touch fitting for ø4
N3	One-touch fitting for ø5/32"

Series SYJ5000



Flat Ribbon Cable Manifold

Common SUP/Common EXH

Note) For more than 8 stations, supply air to both sides of P port and exhaust air from both sides of R port.

Type 20 (5 Port/Body ported)

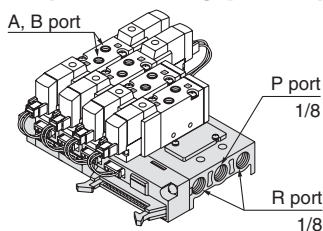

How to Order

SS5YJ5-20P-05-□-Q

Number of stations

03	3 stations
:	:
12	12 stations

P, R port thread type

-	Rc
00F	G
00N	NPT
00T	NPTF

Applicable solenoid valve
Refer to page 35.

Applicable blanking plate assembly
SYJ5000-21-3A-1-Q

Applicable connector assembly
Refer to page 35.

Type 41P (5 Port/Base mounted)

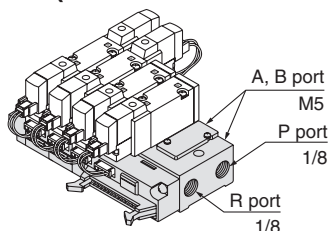

How to Order

SS5YJ5-41P-05-M5-□-Q

Number of stations

03	3 stations
:	:
12	12 stations

P, R port thread type

-	Rc
F	G
N	NPT
T	NPTF

Applicable solenoid valve
Refer to page 35.

Applicable blanking plate assembly
SYJ5000-21-3A-2-Q

Type 43P (5 Port/Base mounted)

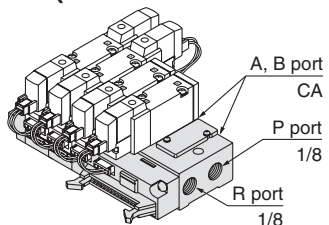

How to Order

SS5YJ5-43P-05-C4-□-Q

Number of stations

03	3 stations
:	:
12	12 stations

A, B port size

C4	One-touch fitting for ø4
N3	One-touch fitting for ø5/32"

P, R port thread type

-	Rc
F	G
N	NPT
T	NPTF

Applicable connector assembly
Refer to page 35.

Combinations of Solenoid Valve, Manifold Gasket and Manifold Base

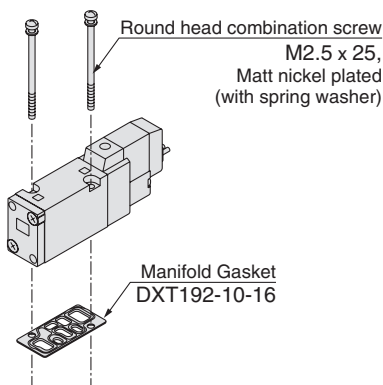
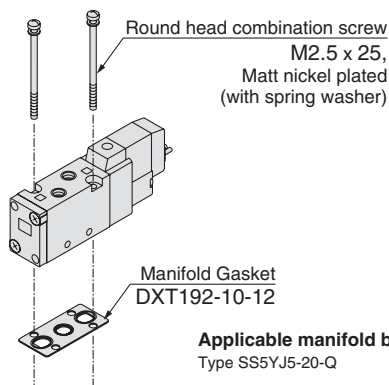

Applicable manifold base

Sub-plate: SYJ5000-22-1□-Q
Type SS5YJ5-40-Q
Type SS5YJ5-41-Q
Type SS5YJ5-42-Q
Type SS5YJ5-43-Q

Thread type

-	Rc
F	G
N	NPT
T	NPTF

Blanking Plate Assembly

SYJ5000-21-1A-1-Q

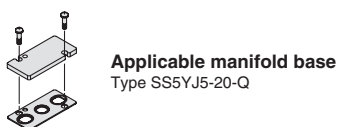

SYJ5000-21-1A-2-Q

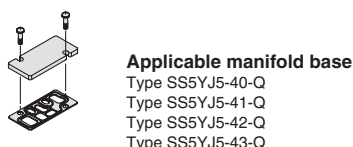

SYJ5000-21-3A-1-Q

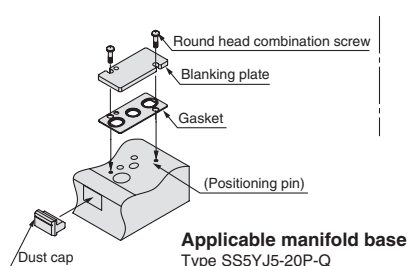

SYJ5000-21-3A-2-Q

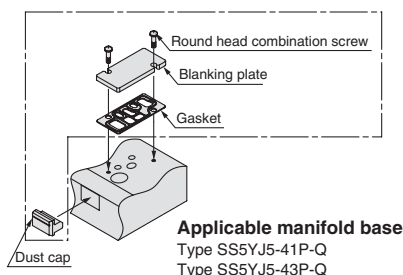

Caution

Mounting screw tightening torques

M2.5: 0.45 N·m

Use caution to the assembly orientation for solenoid valves, gasket, and optional parts.

Mix Installation of the SYJ500 and the SYJ5000 Valves on the Same Manifold

- Use of an adapter plate makes it possible to mount Series SYJ500 on the manifold bases of series SYJ5000.
- When mounting the SYJ500 valve on the SYJ5000 manifold, the SYJ500 solenoid must be positioned on the same side of the manifold as a single solenoid SYJ500. (Refer to the figure below.)
- For base mounted style, the A port of the 3 port valve flows out the B port of manifold base.

Adapter Plate Assembly

SYJ500-3-1A-1-Q

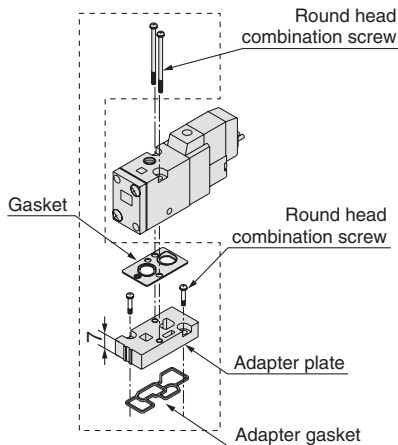

Applicable manifold base

- Type SS5YJ5-20-Q
- Type SS5YJ5-20P-Q
- Type SS5YJ5-20SA-Q

SYJ500-3-1A-2-Q

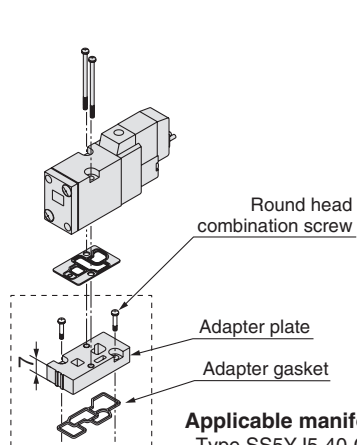

Applicable manifold base

- Type SS5YJ5-40-Q
- Type SS5YJ5-41-Q
- Type SS5YJ5-42-Q
- Type SS5YJ5-43-Q
- Type SS5YJ5-41P-Q
- Type SS5YJ5-43P-Q
- Type SS5YJ5-41SA-Q
- Type SS5YJ5-42SA-Q
- Type SS5YJ5-43SA-Q

Interface Regulator (P port regulation)

Spacer type regulating valve on manifold block can regulate the pressure to the valve individually.

ARBYJ5000-00-P-Q

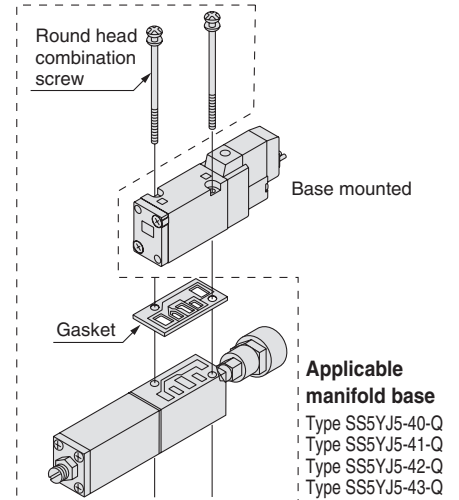

Refer to back page 12 prior to handling.

Individual EXH Spacer Assembly

SYJ5000-17-3 □ A-Q

Thread type

—	Rc
F	G
N	NPT
T	NPTF

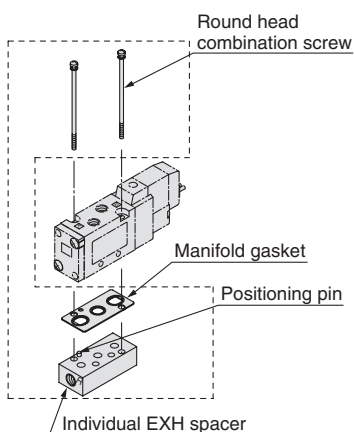

Applicable manifold base

- Type SS5YJ5-20-Q
- Type SS5YJ5-20P-Q
- Type SS5YJ5-20SA-Q

SYJ5000-17-4 □ A-Q

Thread type

—	Rc
F	G
N	NPT
T	NPTF

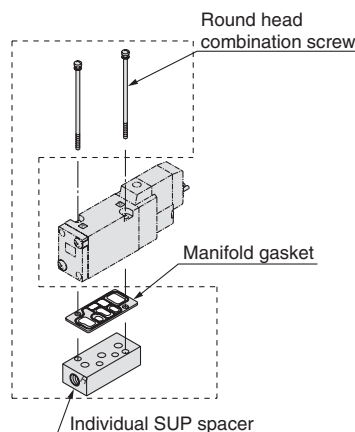

Applicable manifold base

- Type SS5YJ5-40-Q
- Type SS5YJ5-41-Q
- Type SS5YJ5-42-Q
- Type SS5YJ5-43-Q
- Type SS5YJ5-41P-Q
- Type SS5YJ5-43P-Q
- Type SS5YJ5-41SA-Q
- Type SS5YJ5-42SA-Q
- Type SS5YJ5-43SA-Q

Individual SUP Spacer Assembly

SYJ5000-16-2 □ A-Q

Thread type

—	Rc
F	G
N	NPT
T	NPTF

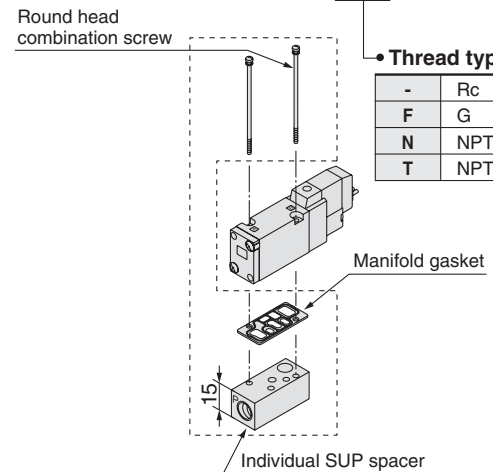

Applicable manifold base

- Type SS5YJ5-41-Q
- Type SS5YJ5-42-Q
- Type SS5YJ5-43-Q
- Type SS5YJ5-41P-Q
- Type SS5YJ5-43P-Q
- Type SS5YJ5-41SA-Q
- Type SS5YJ5-42SA-Q
- Type SS5YJ5-43SA-Q

Caution

Mounting screw tightening torques

M2.5: 0.45 N·m

Use caution to the assembly orientation for solenoid valves, gasket, and optional parts.

Series SYJ5000

Type 20: Top Ported/SS5YJ5-20- Stations -00□-Q

Grommet (G)

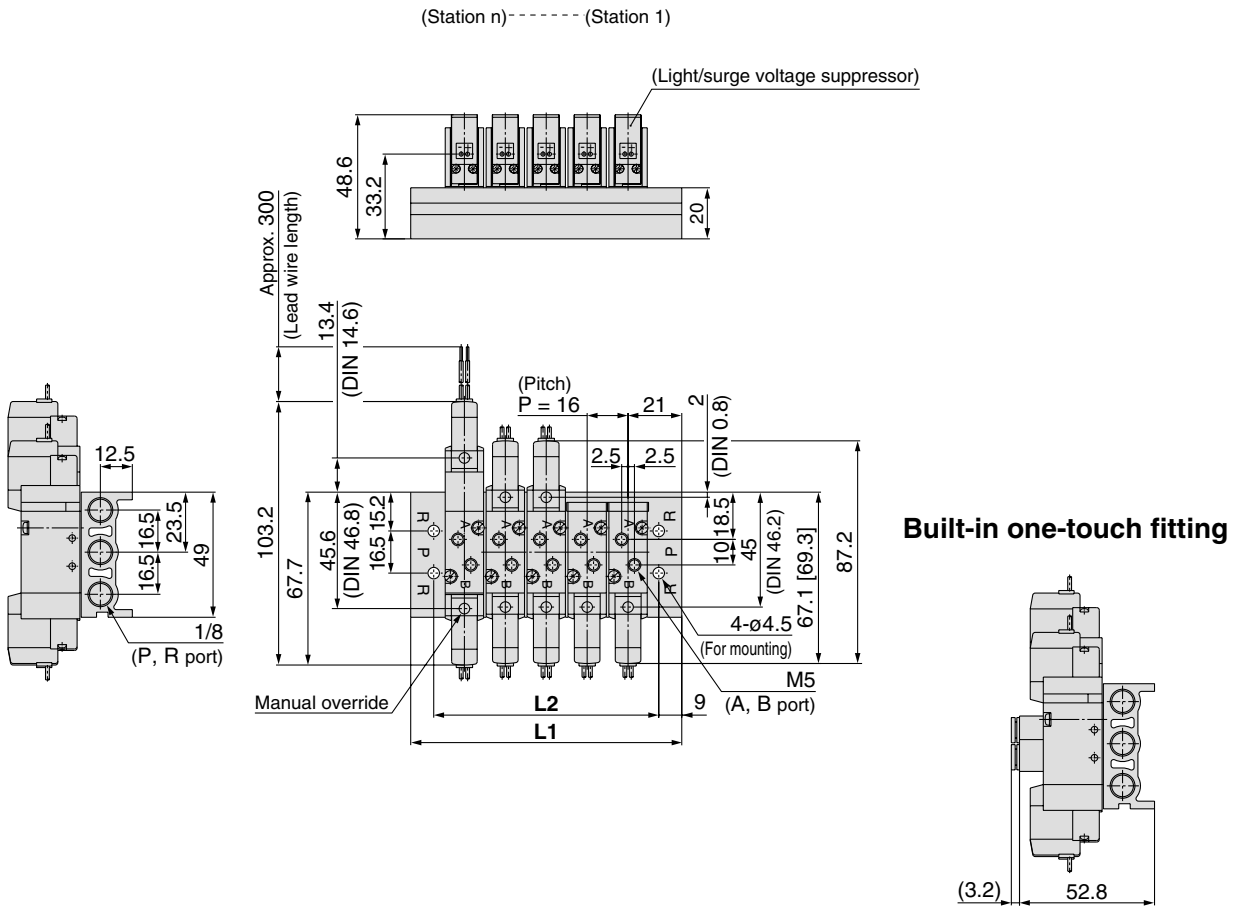

L plug connector (L)

M plug connector (M)

DIN terminal (D)

M8 connector (WO)

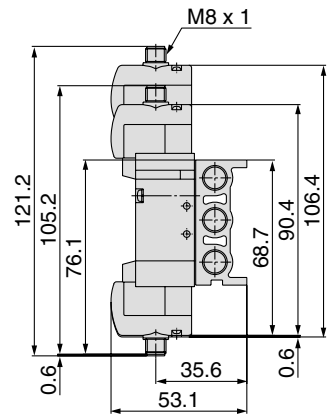
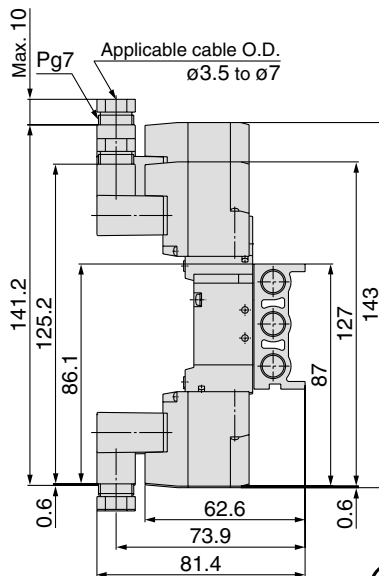
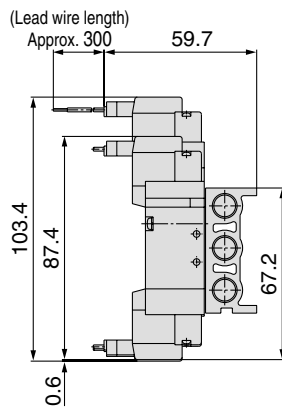
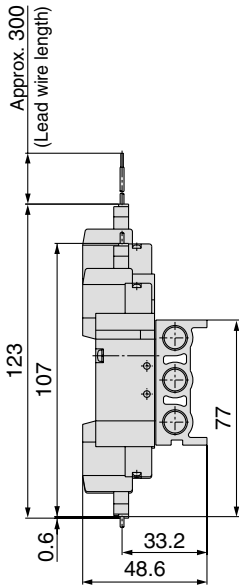

Refer to back page 11 for dimensions with connector cable.

Station n	Station 2	3	4	5	6	7	8	9	10	11	12	13	14	15	16	17	18	19	Station 20
L1	58	74	90	106	122	138	154	170	186	202	218	234	250	266	282	298	314	330	346
L2	40	56	72	88	104	120	136	152	168	184	200	216	232	248	264	280	296	312	328

Type 40: Bottom Ported/SS5YJ5-40- Stations -M5□-Q

Grommet (G)

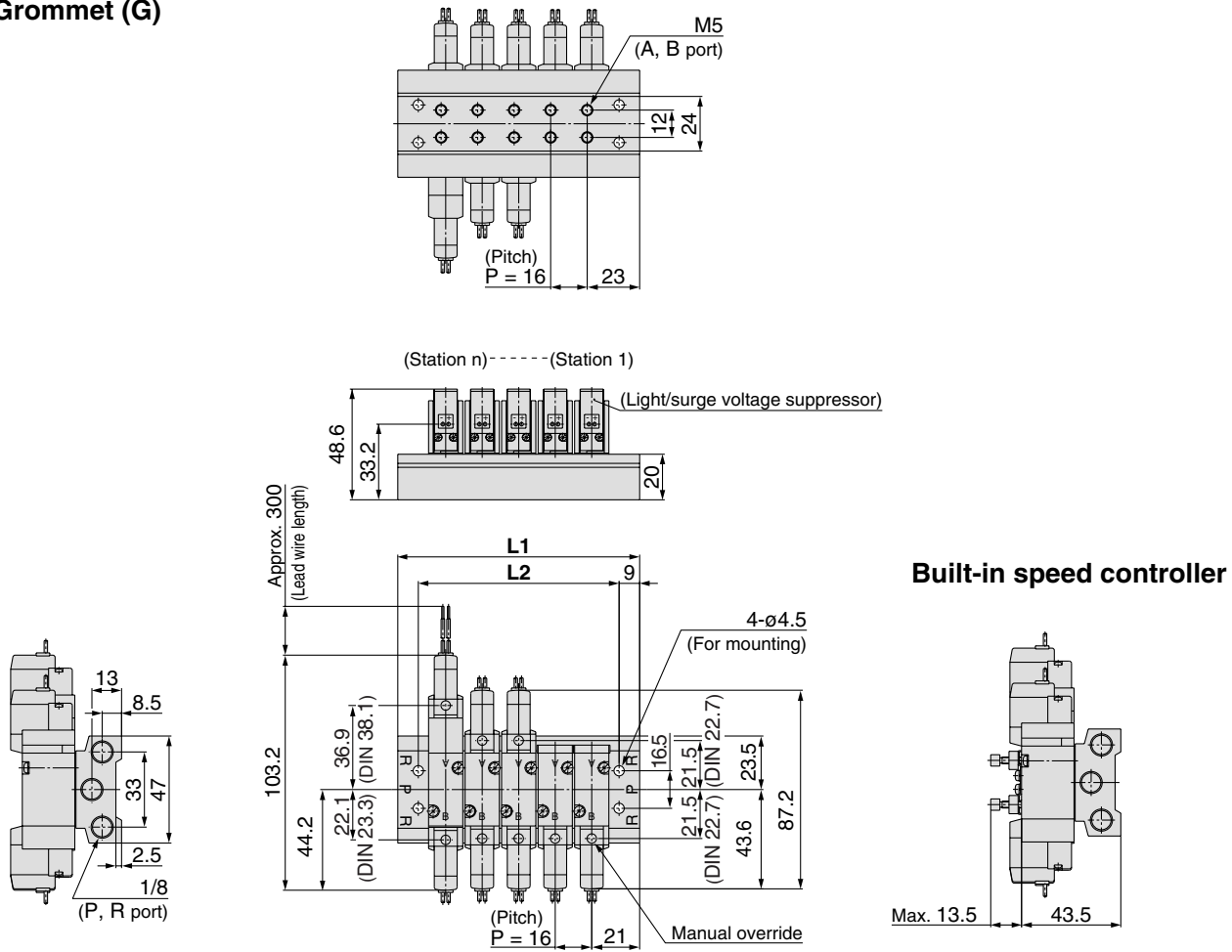

L plug connector (L)

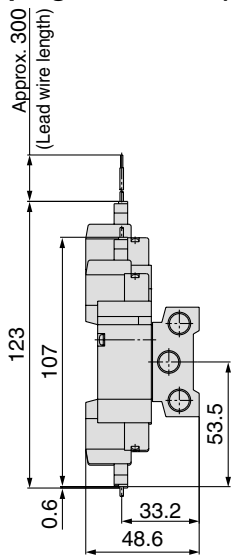

M plug connector (M)

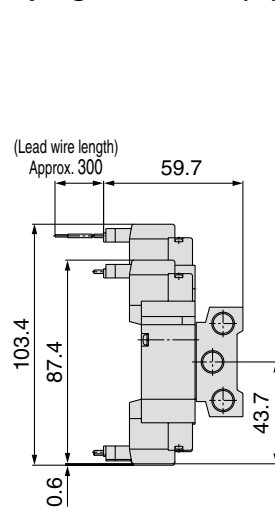

DIN terminal (D)

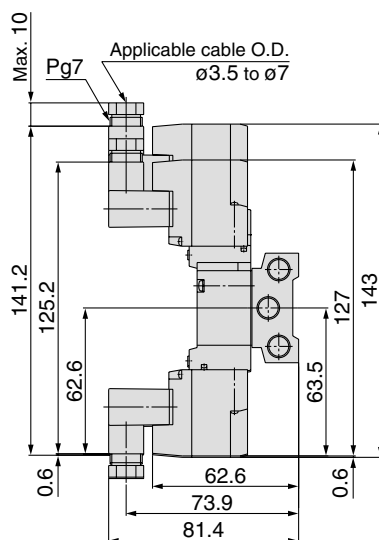

M8 connector (WO)

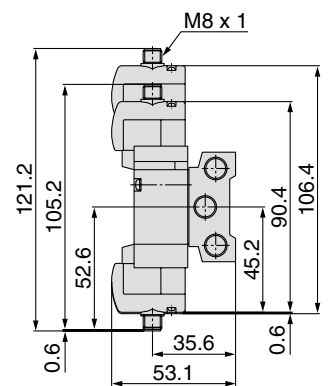

Refer to back page 11 for dimensions with connector cable.

Station n	Station 2	3	4	5	6	7	8	9	10	11	12	13	14	15	16	17	18	19	Station 20
L1	58	74	90	106	122	138	154	170	186	202	218	234	250	266	282	298	314	330	346
L2	40	56	72	88	104	120	136	152	168	184	200	216	232	248	264	280	296	312	328

Series SYJ5000

Type 41: Side Ported/SS5YJ5-41- Stations -M5□-Q

Grommet (G)

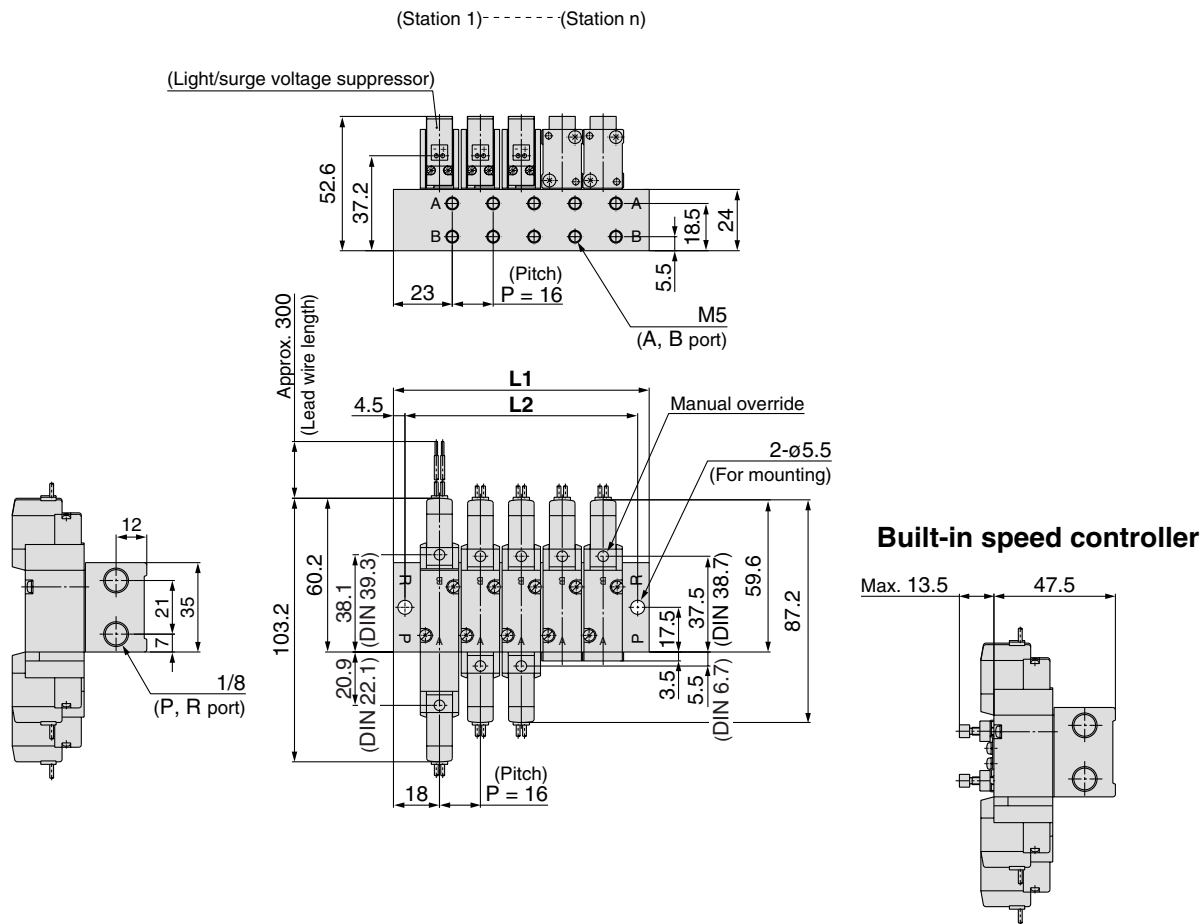

L plug connector (L)

M plug connector (M)

DIN terminal (D)

M8 connector (WO)

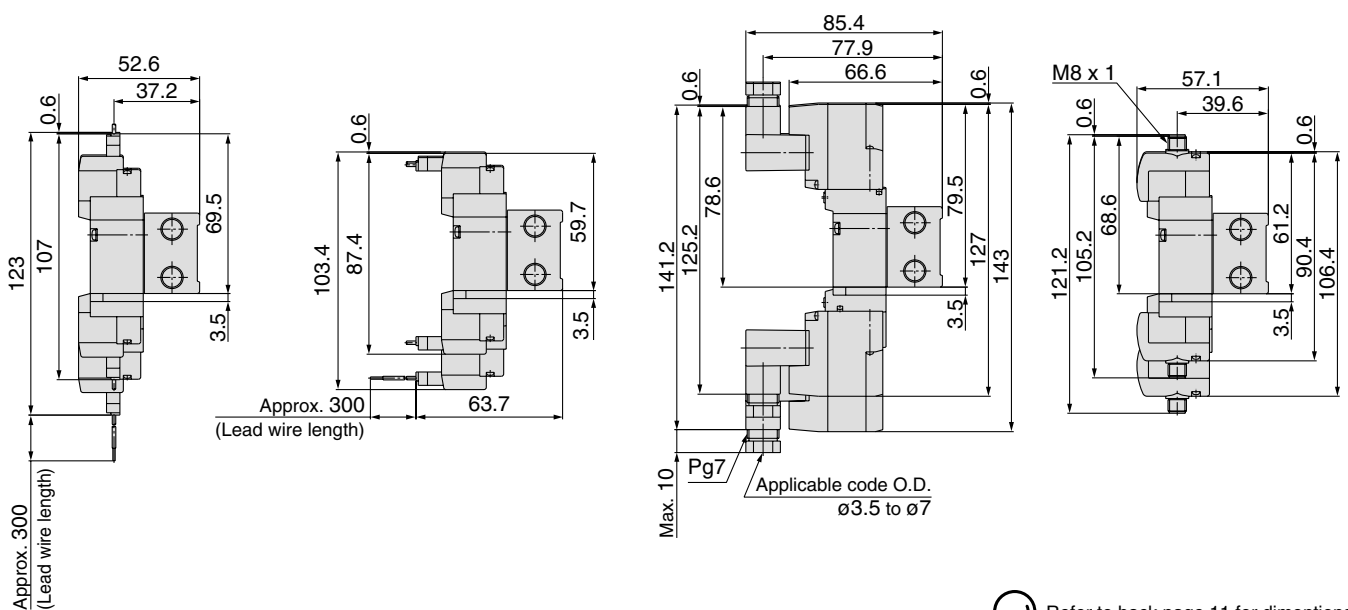

Refer to back page 11 for dimensions with connector cable.

Station n	Station 2	3	4	5	6	7	8	9	10	11	12	13	14	15	16	17	18	19	Station 20
L1	52	68	84	100	116	132	148	164	180	196	212	228	244	260	276	292	308	324	340
L2	43	59	75	91	107	123	139	155	171	187	203	219	235	251	267	283	299	315	331

Type 42: Side Ported/SS5YJ5-42- Stations -01, C6 N7 □-Q

Grommet (G)
For 01 □

For C6 N7 □ (Built-in one-touch fitting)

Built-in speed controller

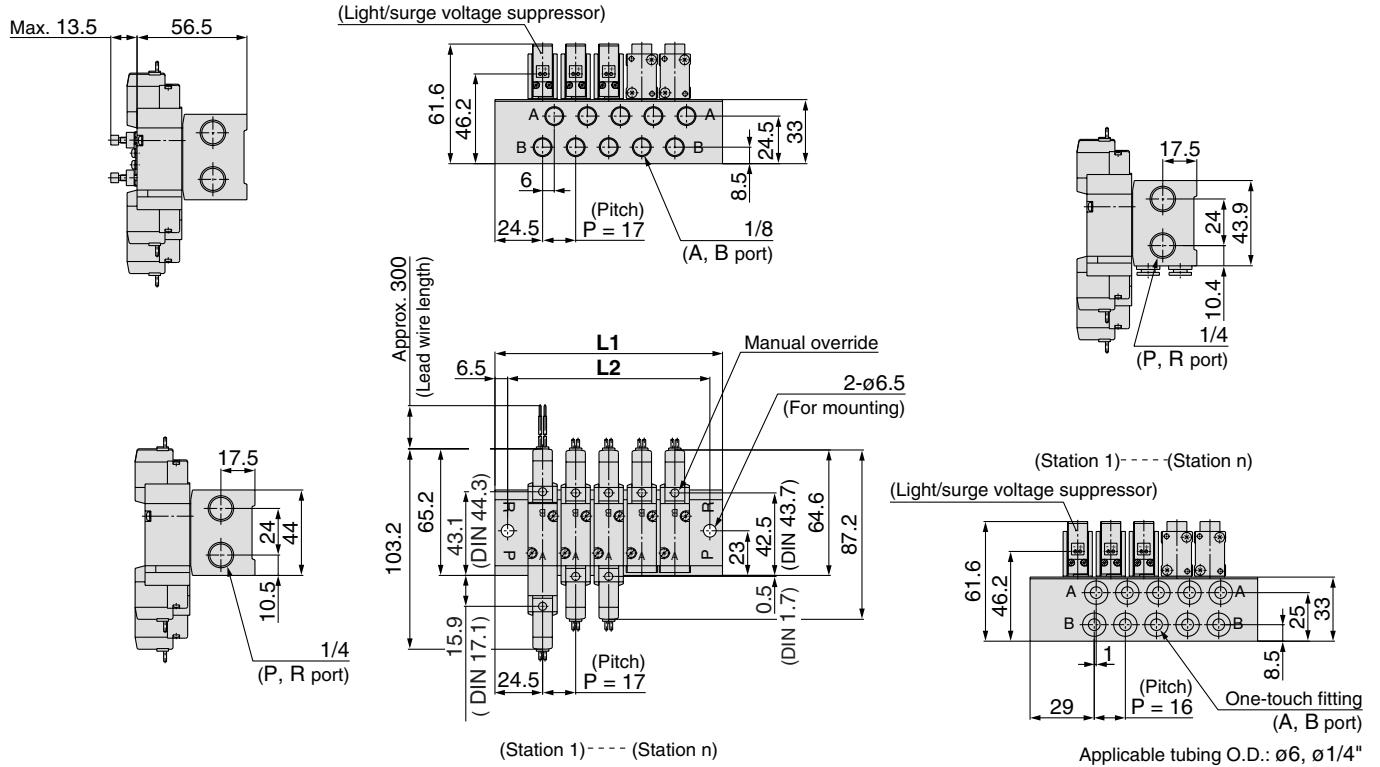

* Other dimensions are the same as the grommet type.

L plug connector (L)

M plug connector (M)

DIN terminal (D)

M8 connector (WO)

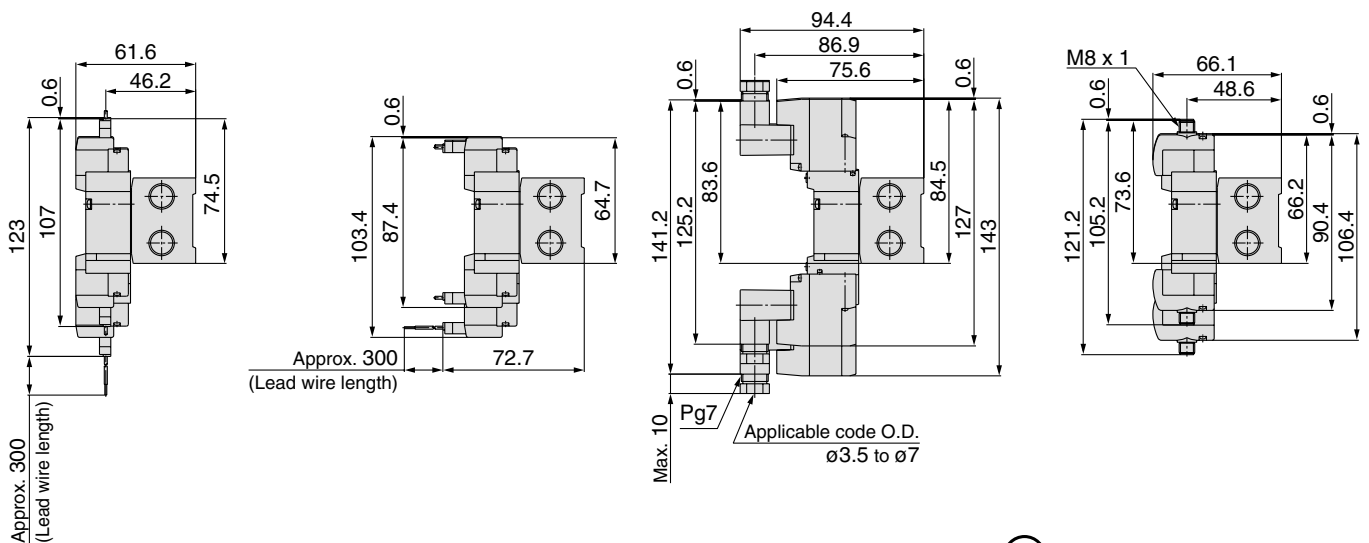

Refer to back page 11 for dimensions with connector cable.

A, B port size	Station n	Station 2	3	4	5	6	7	8	9	10	11	12	13	14	15	16	17	18	19	Station 20
For 1/8	L1	66	83	100	117	134	151	168	185	202	219	236	253	270	287	304	321	338	355	372
	L2	53	70	87	104	121	138	155	172	189	206	223	240	257	274	291	308	325	342	359
For C6/N7	L1	65	81	97	113	129	145	161	177	193	209	225	241	257	273	289	305	321	337	353
	L2	52	68	84	100	116	132	148	164	180	196	212	228	244	260	276	292	308	324	340

Series SYJ5000

Type 43: Side Ported/SS5YJ3-43- Stations \square C4 N3 \square -Q

Grommet (G)

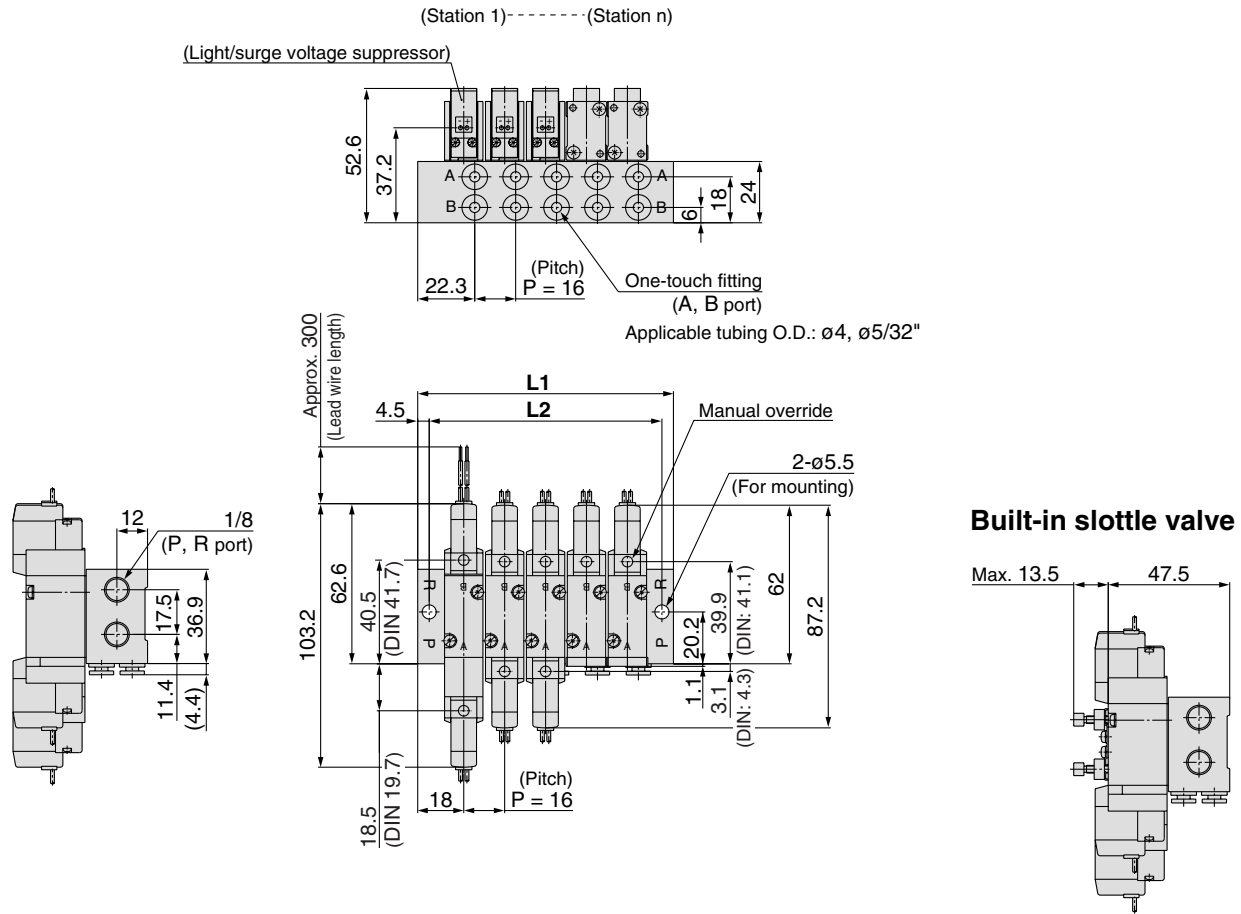

L plug connector (L)

M plug connector (M)

DIN terminal (D)

M8 connector (WO)

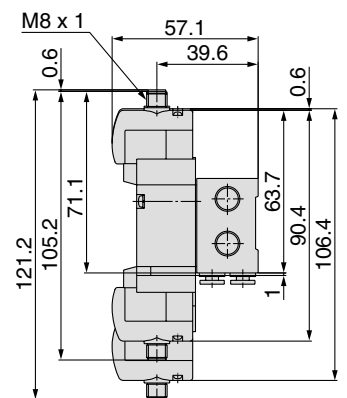
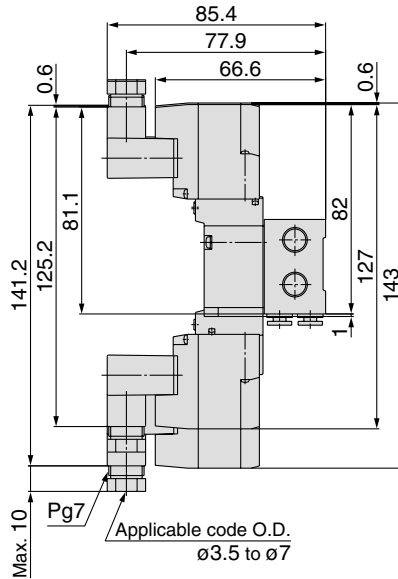
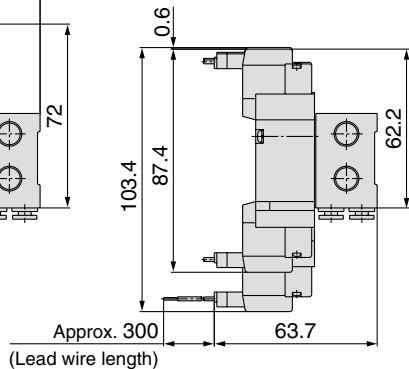
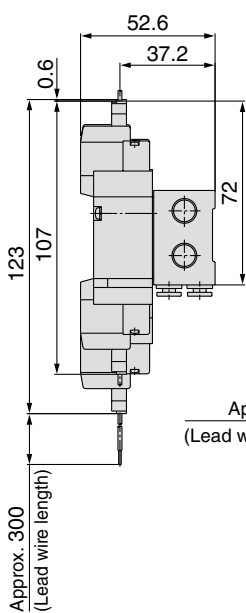

Refer to back page 11 for dimensions with connector cable.

Station n	Station 2	3	4	5	6	7	8	9	10	11	12	13	14	15	16	17	18	19	Station 20
L1	52	68	84	100	116	132	148	164	180	196	212	228	244	260	276	292	308	324	340
L2	43	59	75	91	107	123	139	155	171	187	203	219	235	251	267	283	299	315	331

Flat Ribbon Cable Manifold

SS5YJ5-20P- Stations -00□-Q

For ^{C4 N3}_{C6 N7} (Built-in one-touch fitting)

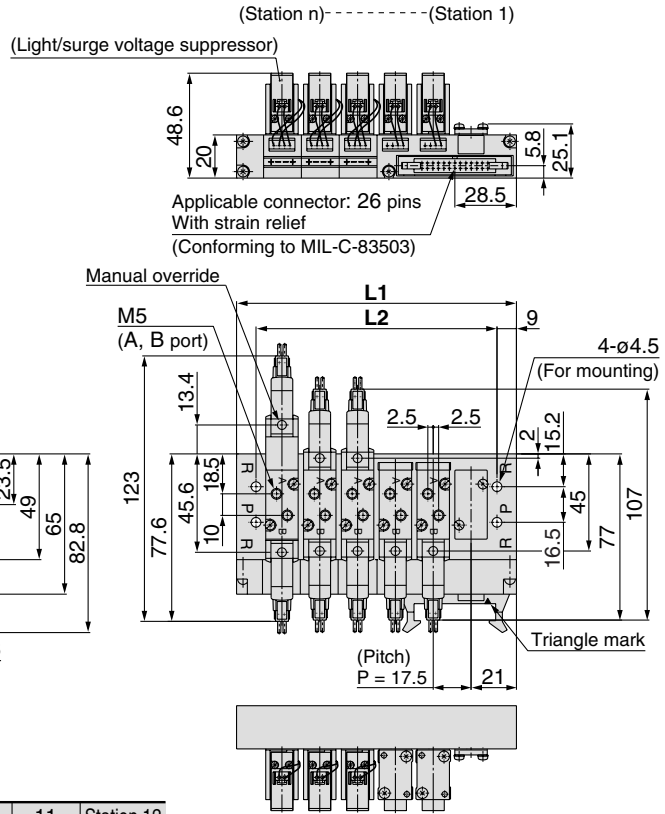
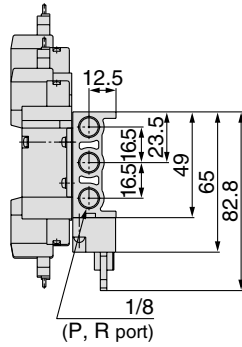
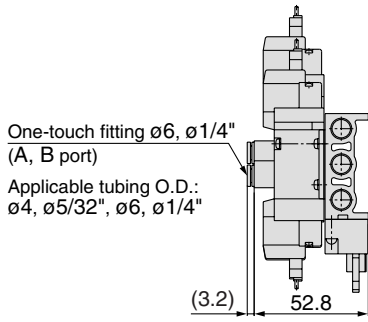

Station n	Station 3	4	5	6	7	8	9	10	11	Station 12
L1	77	94.5	112	129.5	147	164.5	182	199.5	217	234.5
L2	59	76.5	94	111.5	129	146.5	164	181.5	199	216.5

SS5YJ5-41P- Stations -M5□-Q

Built-in slottle valve

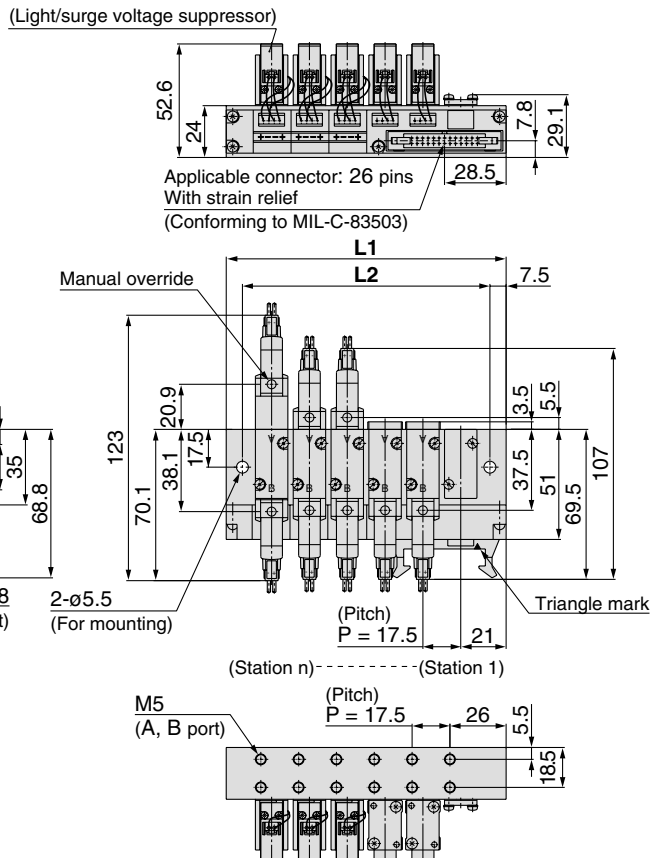
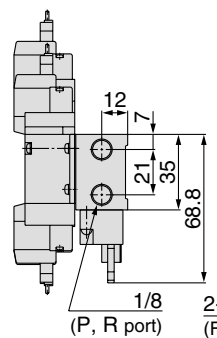
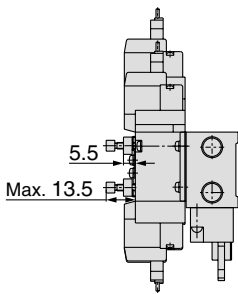

Station n	Station 3	4	5	6	7	8	9	10	11	Station 12
L1	77	94.5	112	129.5	147	164.5	182	199.5	217	234.5
L2	62	79.5	97	114.5	132	149.5	167	184.5	202	219.5

Series SYJ5000

Flat Ribbon Cable Manifold

SS5YJ5-43P- Stations $\square_{N3}^{C4} \square - Q$

(Pitch)
P = 17.5

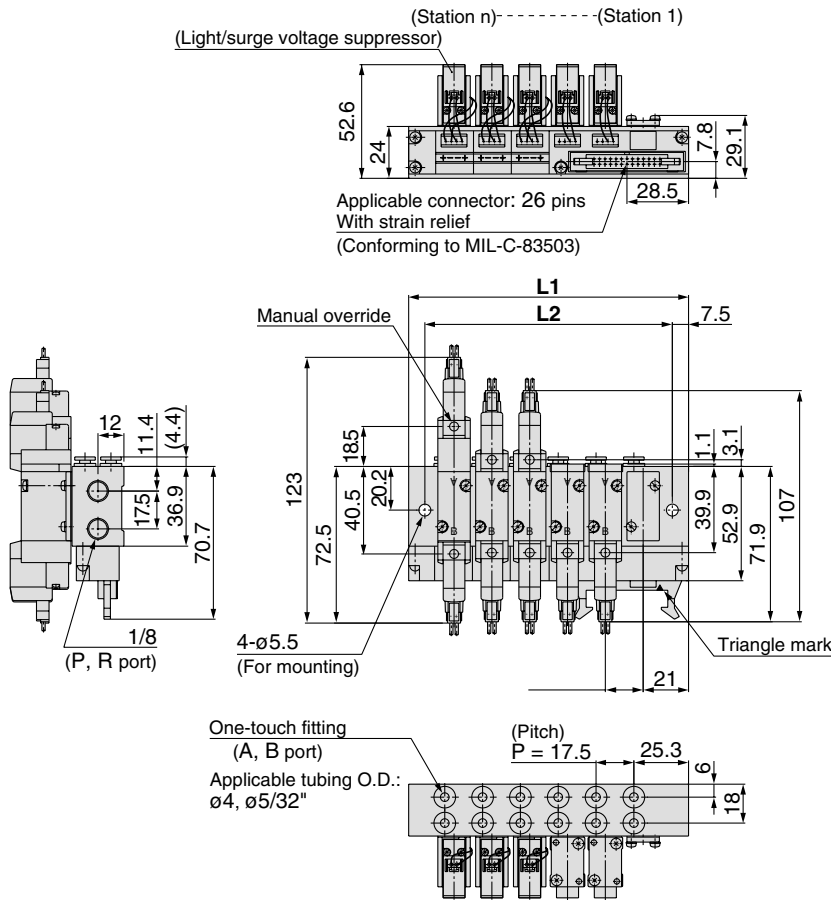

Built-in speed controller

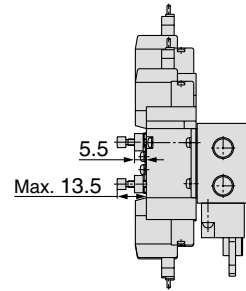

Station n	Station 3	4	5	6	7	8	9	10	11	Station 12
L1	77	94.5	112	129.5	147	164.5	182	199.5	217	234.5
L2	62	79.5	97	114.5	132	149.5	167	184.5	202	219.5

Rubber Seal 5 Port Solenoid Valve



Series SYJ7000



For details about certified products conforming to international standards, visit us at www.smcworld.com.

Specifications

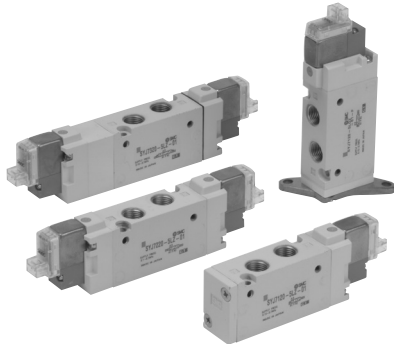

Body ported

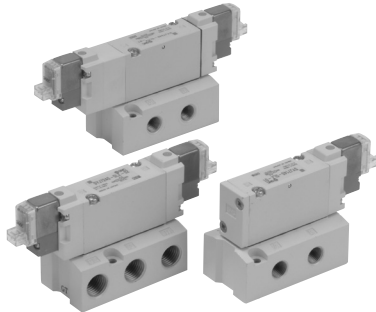

Base mounted

Fluid	Air	
Operating pressure range (MPa)	2 position single	0.15 to 0.7
	2 position double	0.1 to 0.7
	3 position	0.15 to 0.7
Ambient and fluid temperature (C)	-10 to 50 (No freezing. Refer to back page 3.)	
Response time (ms) ^{Note 1)} (at 0.5 MPa)	2 position single, double	30 or less
	3 position	60 or less
Max. operating frequency (Hz)	2 position single, double	5
	3 position	3
Manual override (Manual operation)	Non-locking push type, Push-turn locking slotted type, Push-turn locking lever type	
Pilot exhaust method	Individual exhaust for the pilot valve, Common exhaust for the pilot and main valve	
Lubrication	Not required	
Mounting orientation	Unrestricted	
Shock/Vibration resistance (m/s²) ^{Note 2)}	150/30	
Enclosure	Dust proof (* DIN terminal, M8 connector conforms to IP65.)	



* Based on IEC60529

Note 1) Based on dynamic performance test, JIS B 8375-1981. (Coil temperature: 20C, at rated voltage, without surge suppressor)

Note 2) Impact resistance:

No malfunction occurred when it is tested in the axial direction and at the right angles to the main valve and armature in both energised and de-energised states every once for each condition. (Value in the initial state)

Vibration resistance: No malfunction occurred in one sweep test between 45 and 2000 Hz. Test was performed to axis and right angle directions of the main valve and armature when pilot signal is ON and OFF. (Value in the initial state)

Solenoid Specifications

JIS Symbol Body ported

2 position single

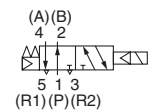

2 position double

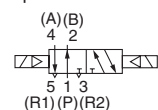

3 position closed center

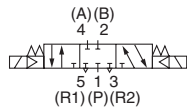

3 position exhaust center

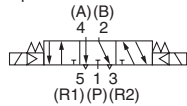

3 position pressure center

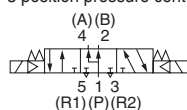

Base mounted

2 position single solenoid

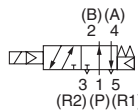

2 position double solenoid

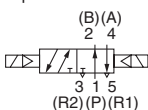

3 position closed center

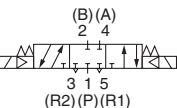

3 position exhaust center

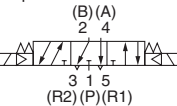

3 position pressure center

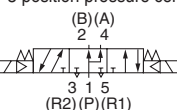

Electrical entry	Grommet (G), (H)		
	L plug connector (L)		
	M plug connector (M)		
	DIN terminal (D)		
	M8 connector (W)		
		G, H, L, M, W	
		D	
Coil rated voltage (V)	DC	24, 12, 6, 5, 3	
	AC 50/60 Hz	100, 110, 200, 220	
Allowable voltage fluctuation	10% of rated voltage *		
Power consumption (W)	DC	Standard	0.35 {With light: 0.4 (DIN terminal with light: 0.45)}
		With power saving circuit	0.1 (With light only)
Apparent power VA*	AC	100 V	- 0.78 (With light: 0.87)
		110 V	- 0.86 (With light: 0.97)
		[115 V]	- [0.94 (With light: 1.07)]
		200 V	- 1.15 (With light: 1.30)
		220 V	- 1.27 (With light: 1.46)
		[230 V]	- [1.39 (With light: 1.60)]
Surge voltage suppressor	Diode (DIN terminal, Varistor when non-polar types)		
Indicator light	LED (Neon light when AC with DIN terminal)		



* In common between 110 VAC and 115 VAC, and between 220 VAC and 230 VAC.

* For 115 VAC and 230 VAC, the allowable voltage is -15% to +5% of rated voltage.

* S, Z and T type (with power saving circuit) should be used within the following allowable voltage fluctuation range due to a voltage drop caused by the internal circuit.

S and Z type: 24 VDC: -7% to +10%, 12 VDC: -4% to +10%

T type: 24 VDC: -8% to +10%, 12 VDC: -6% to +10%



Made to Order

(For details, refer to pages 78 through to 80.)

Flow Characteristics/Weight

Valve model	Type of actuation	Port size		Flow characteristics <small>Note 1)</small>								Weight (g) <small>Note 2, 3)</small>					
		1,5,3 (P,EA,EB)	4,2 (A,B)	1→4/2 (P→A/B)				4/2→5/3 (A/B→EA/EB)				Grommet	L/M plug connector	DIN terminal	M8 connector		
				C [dm ³ /s-bar]	b	Cv	Q _l (min)(ANR) [*]	C [dm ³ /s-bar]	b	Cv	Q _l (min)(ANR) [*]						
Body ported	SYJ7□20-□-01	2 position	Single	1/8	1/8	2.2	0.36	0.58	582	2.4	0.34	0.63	626	85	86	107	90
			Double			1.8	0.37	0.45	479	2.0	0.35	0.49	525	98	100	142	108
		3 position	Exhaust center			1.2	0.50	0.34	353	3.0 [1.3]	0.35[0.52]	0.73 [0.39]	788 [389]	108	110	152	118
			Pressure center			3.0 [0.83]	0.37 [0.50]	0.78 [0.25]	799 [244]	1.8	0.37	0.45	479				
	SYJ7□20-□-C6	2 position	Single	1/8	C6 (One-touch fitting for ø8)	1.6	0.33	0.4	415	2.2	0.32	0.53	567	96	97	98	101
			Double			1.4	0.27	0.35	349	1.9	0.33	0.49	493	109	111	153	119
		3 position	Exhaust center			1.1	0.37	0.27	293	2.5 [1.3]	0.32[0.54]	0.61 [0.38]	644 [395]	119	121	163	129
			Pressure center			1.8 [0.78]	0.36 [0.40]	0.45 [0.22]	476 [212]	1.6	0.30	0.39	407				
	SYJ7□20-□-C8	2 position	Single	1/8	C8 (One-touch fitting for ø8)	2.0	0.39	0.52	540	2.3	0.34	0.61	600	96	97	98	101
			Double			1.7	0.35	0.42	447	2.0	0.29	0.49	505	109	111	153	119
		3 position	Exhaust center			1.2	0.38	0.33	322	2.6 [1.3]	0.35[0.49]	0.67 [0.38]	683 [379]	119	121	163	129
			Pressure center			1.9 [0.86]	0.57 [0.46]	0.59 [0.25]	584 [245]	1.7	0.39	0.42	459				
Base mounted	SYJ7□40-□-01	2 position	Single	1/8	1/8	2.3	0.45	0.57	649	2.8	0.37	0.71	746	165 (85)	166 (86)	187 (107)	170 (90)
			Double			1.9	0.36	0.48	503	2.1	0.46	0.57	598	178 (98)	180 (100)	222 (142)	188 (108)
		3 position	Exhaust center			1.2	0.48	0.35	347	3.4 [1.3]	0.36[0.57]	0.86 [0.41]	899 [406]	188 (108)	190 (110)	232 (152)	198 (118)
			Pressure center			3.3 [0.85]	0.43 [0.54]	0.78 [0.25]	918 [259]	2.1	0.45	0.56	593				
	SYJ7□40-□-02	2 position	Single	1/4	1/4	2.3	0.41	0.61	630	2.9	0.35	0.74	762	165 (85)	166 (86)	187 (107)	170 (90)
			Double			1.9	0.46	0.50	541	2.2	0.44	0.60	616	178 (98)	180 (100)	222 (142)	188 (108)
		3 position	Exhaust center			1.3	0.45	0.35	367	3.7 [1.4]	0.27[0.56]	0.87 [0.43]	923 [434]	188 (108)	190 (110)	232 (152)	198 (118)
			Pressure center			3.6 [0.83]	0.23 [0.55]	0.84 [0.25]	877 [255]	2.1	0.47	0.58	602				



Note 1) []: denotes the normal position. Exhaust center: 4/2 → 5/3, Pressure center: 1 → 4/2
 Note 2) (): Without sub-plate.
 Note 3) For DC voltages. For AC voltages add 3 g to the weight of the single solenoid and 6 g to the weight of the double solenoid and 3 position types.
 * These values have been calculated according to ISO6358 and represent the flow rate measured in standard conditions at an upstream of 0.6MPa (relative pressure) and a differential pressure of 0.1MPa.

Cylinder Speed Chart

Body Ported

Use as a guide for selection.
 Please confirm the actual conditions with SMC Sizing Program.

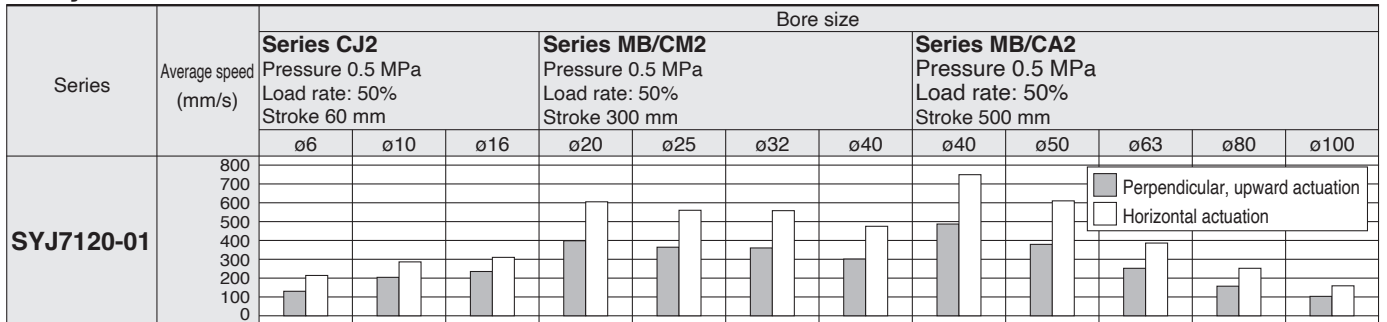

Base Mounted

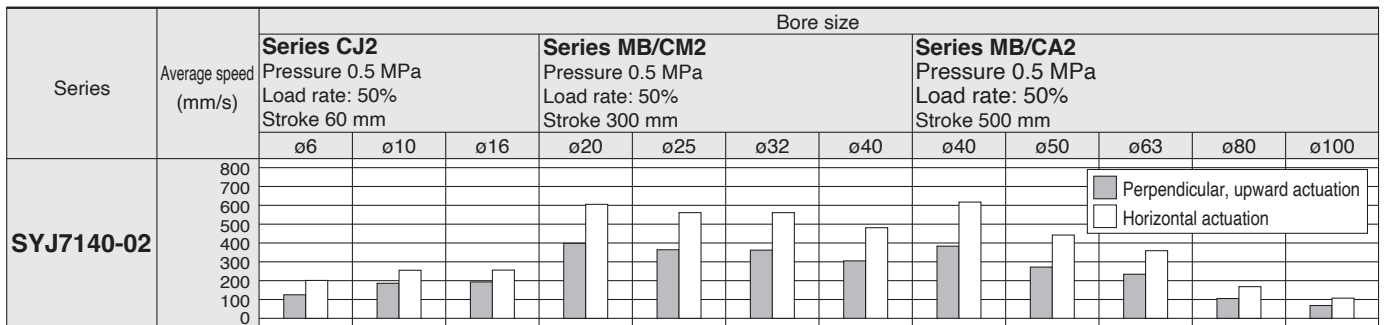

* Cylinder is in extending. Speed controller is meter-out, which is directly connected with cylinder and its needle is fully opened.
 * Average speed of cylinder is obtained by dividing the full stroke time by the stroke.
 * Load factor: ((Load weight x 9.8) / Theoretical force) x 100%

Conditions

	Body ported	Series CJ2	Series CM2	Series MB/CA2
SYJ7120-01	Tubing bore x Length	ø6 x 1 m		
	Speed controller	AS2301F-06	AS3301F-06	AS4001F-12
	Silencer	AN110-01		

	Base mounted	Series CJ2	Series CM2	Series MB/CA2
SYJ7140-02	Tubing bore x Length	ø6 x 1 m		
	Speed controller	AS1301F-06	AS3001F-06	
	Silencer	AN20-02		

How to Order

Type of actuation

1	2 position single solenoid
2	2 position double solenoid
3	3 position closed center
4	3 position exhaust center
5	3 position pressure center

Light/surge voltage suppressor

Electrical entry for G, H, L, M, W

-	Without light/surge voltage suppressor
S	With surge voltage suppressor
Z	With light/surge voltage suppressor
R	With surge voltage suppressor (Non-polar type)
U	With light/surge voltage suppressor (Non-polar type)

* Power saving circuit is only available in the "Z" type.

Electrical entry for D

-	Without light/surge voltage suppressor
S	With surge voltage suppressor (Non-polar type)
Z	With light/surge voltage suppressor (Non-polar type)

* DOZ is not available.
* For AC voltage valves there is no "S" option. It is already built-in to the rectifier circuit.

Thread type

-	Rc
F	G
N	NPT
T	NPTF

Bracket

-: Without bracket
F: With bracket

Note) Do not remove the factory installed bracket from models with the bracket option. Removal of the bracket will cause the valve to leak. Brackets cannot be retrofitted.

Rated voltage

DC	AC (50/60 Hz)
5	1
6	2
V	3
S	4
R	

DC specifications of type D and DO is only available with 12 and 24 VDC.
AC specification is only available with D, DO type.

A, B port size

01	1/8
C6	One-touch fitting for ø6
C8	One-touch fitting for ø8
N7	One-touch fitting for ø1/4"
N9	One-touch fitting for ø5/16"

Body ported SYJ7 **1 2 0** **5 M** **01** **Q**

Base mounted SYJ7 **2 4 0** **5 M** **Q**

Body option

0: Pilot valve individual exhaust for the pilot valve

R port P, E port

3: Common exhaust type for main and pilot valve

R port P, E port

Coil specifications

-	Standard
T	With power saving circuit <24 V, 12 VDC only>

* Power saving circuit is not available in the case of D, DO or W□ type.

Manual override

-: Non-locking push type

D: Push-turn locking slotted type

E: Push-turn locking lever type

Thread type

-	Rc
F	G
N	NPT
T	NPTF

Electrical entry

24, 12, 6, 5, 3 VDC				24,12 VDC 100,110, 200, 220 VAC	24, 12, 6, 5, 3 VDC
Grommet	L plug connector	M plug connector		DIN terminal	M8 connector *
G: Lead wire length 300 mm	L: With lead wire (Length 300 mm)	M: With lead wire (Length 300 mm)	MN: Without lead wire	D: With connector	WO: Without connector cable
H: Lead wire length 600 mm	LN: Without lead wire	LO: Without connector	MO: Without connector	DO: Without connector	W□: With connector cable <small>Note 1)</small>

Note 1) Enter the cable length symbols in □. Please be sure to fill in the blank referring to back page 10.

Port size

-: Without sub-plate

(With gasket and screws)

01: 1/8 With sub-plate Note)

02: 1/4 With sub-plate

Note) R1, R2 port: 1/4

* LN, MN type: with 2 sockets.
 * DIN terminal type "Y" which conforms to EN-175301-803C (former DIN43650C) is also available. For details, refer to page 79.
 * For connector cable of M8 connector, refer to back page 10.
 * Connector M8 type "WA" conforming to IEC 60947-5-2 standard, is also available. For details, see page 80.

Construction

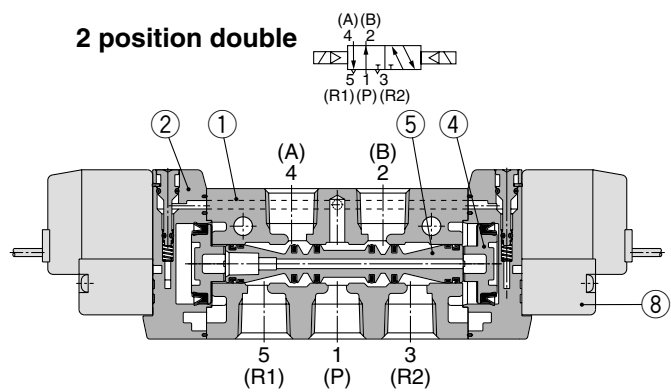
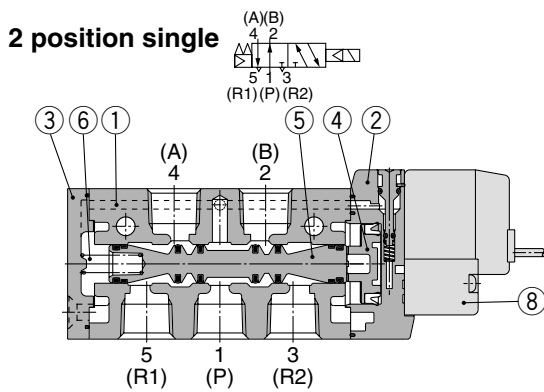

3 position closed center/exhaust center/pressure center

3 position closed center

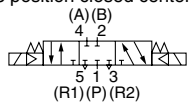

3 position exhaust center

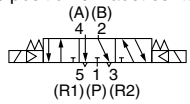

3 position pressure center

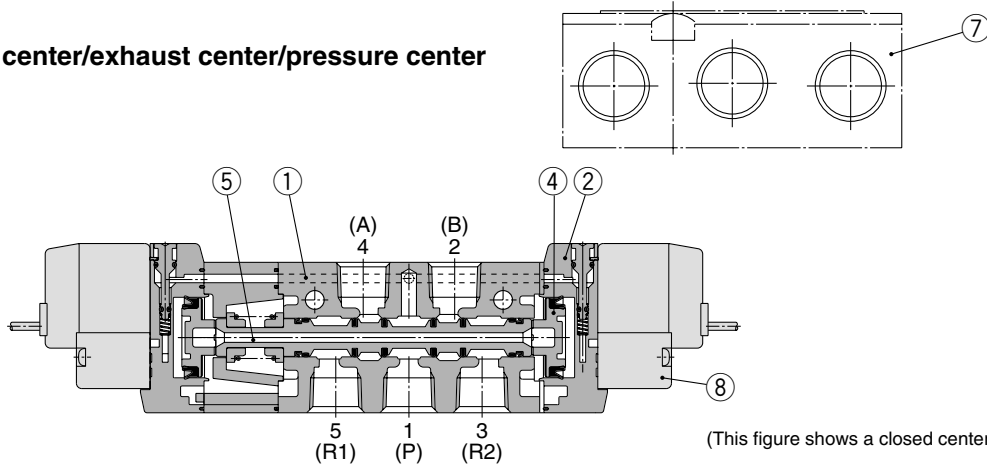
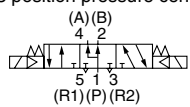

Component Parts

No.	Description	Material	Note
1	Body	Aluminum die-casted	White
2	Piston plate	Resin	White
3	End cover	Aluminum die-casted	White
4	Piston	Resin	—
5	Spool valve assembly	Aluminum, H-NBR	—
6	Spool spring	Stainless steel	—

Replacement Parts

No.	Description	No.	Note
7	Sub-plate	SYJ7000-22-1-Q	1/8 Aluminum die-casted
		SYJ7000-22-2-Q	1/4
8	Pilot valve	V111(T)-□□□	—

How to Order Pilot Valve Assembly

V111 — 5 G

Coil specifications

-	Standard
T	With power saving circuit (24, 12 VDC only)

* Power saving circuit is not available in the case of W□ type.

Rated voltage

5	24 VDC
6	12 VDC
V	6 VDC
S	5 VDC
R	3 VDC

Light/surge voltage suppressor

-	Without light/surge voltage suppressor
S	With surge voltage suppressor
Z	With light/surge voltage suppressor
R	With surge voltage suppressor (Non-polar type)
U	With light/surge voltage suppressor (Non-polar type)

* Power saving circuit is only available in the "Z" type.

Electrical entry

G	Grommet, 300 mm lead wire	
H	Grommet, 600 mm lead wire	
L	L plug	With lead wire
LN	L plug connector	Without lead wire
LO		Without connector
M	M plug	With lead wire
MN	M plug connector	Without lead wire
MO		Without connector
WO	M8	Without connector cable
W□	connector	With connector cable (Note 1)

* For connector cable of M8 connector, refer to back page 10.

V115 — 5 D

Rated voltage

5	24 VDC
6	12 VDC
1	100 VAC 50/60 Hz
2	200 VAC 50/60 Hz
3	110 VAC 50/60 Hz [115 V AC 50/60 Hz]
4	220 VAC 50/60 Hz [230 VAC 50/60 Hz]

Light/surge voltage suppressor

-	Without light/surge voltage suppressor
S	With surge voltage suppressor (Non-polar type)
Z	With light/surge voltage suppressor (Non-polar type)

* DOZ is not available.
* For AC voltage valves there is no "S" option. It is already built-in to the rectifier circuit.

Electrical entry

D	DIN	With connector
DO	terminal	Without connector

Note 1) Enter the cable length symbols in □. Please be sure to fill in the blank referring to back page 10.

Note) Do not replace V111 (G, H, L, M, W) to V115 (DIN terminal) and vice versa when replacing pilot valve assembly only.

Series SYJ7000

How to Order Connector Assembly for L/M Plug Connector

For DC : SY100-30-4A- 

Without lead wire: SY100-30-A
(with connector and 2 of sockets only)

Lead wire length ●

-	300 mm
6	600 mm
10	1000 mm
15	1500 mm
20	2000 mm
25	2500 mm
30	3000 mm
50	5000 mm

How to Order M8 Connector Cable

V100-49-1- 

● Cable length

1	300 mm
2	500 mm
3	1000 mm
4	2000 mm
7	5000 mm

2 Position Single

Grommet (G), (H): SYJ7120-□^G□□-01□-Q

With bracket:

SYJ7120-□^G□□-01□-F-Q

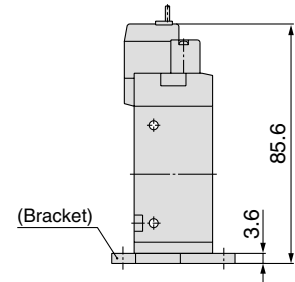
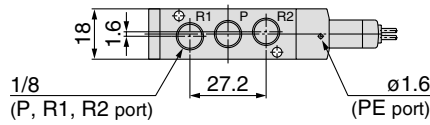

(Light/surge voltage suppressor)

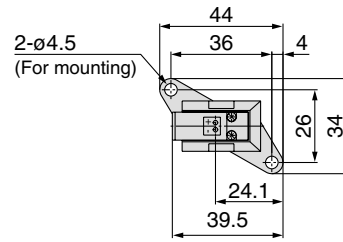
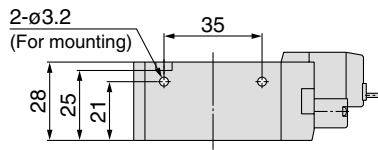
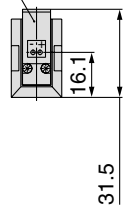

G: Approx. 300
H: Approx. 600
(Lead wire length)

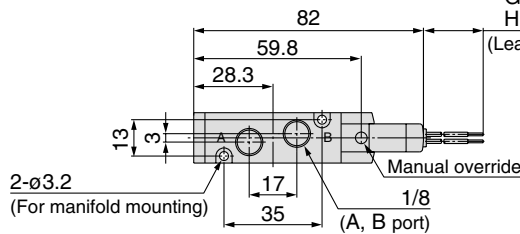

Built-in one-touch fitting:

SYJ7120-□^G□□-□^{C6, N7}□□-□^{C8, N9}□ (-F)-Q

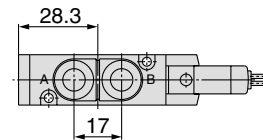
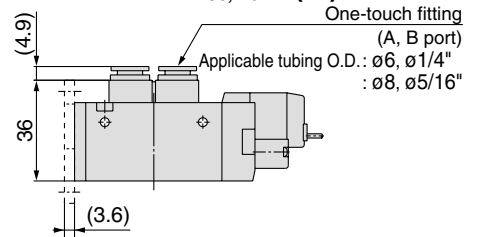

L plug connector (L): SYJ7120-□L□□-01□ (-F)-Q

M plug connector (M): SYJ7120-□M□□-01□ (-F)-Q

DIN terminal (D): SYJ7120-□D□□-01□ (-F)-Q

M8 connector (WO): SYJ7120-□WO□□-01□ (-F)-Q

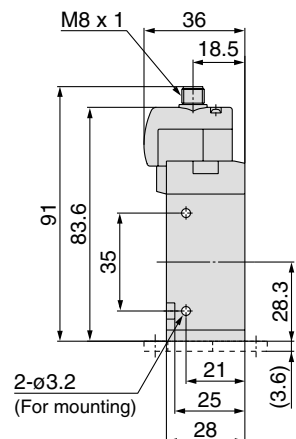
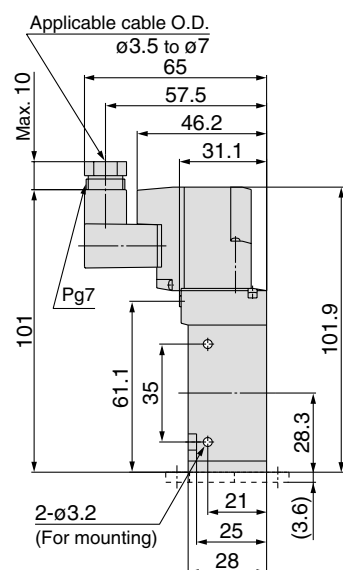
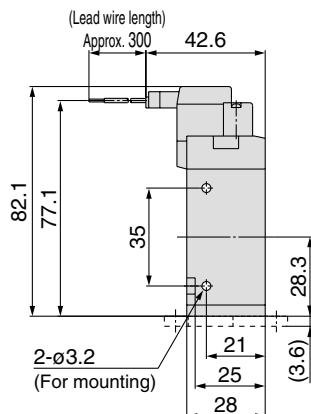
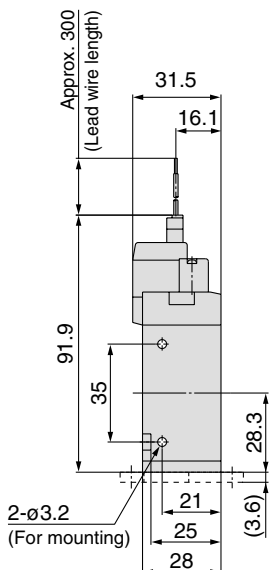

Refer to back page 11 for dimensions with connector cable.

Series SYJ7000

2 Position Double

Grommet (G), (H): SYJ7220-□^G□□-01□-Q

Built-in one-touch fitting:
SYJ7220-□^G□□-C6, N7, N9 □-Q

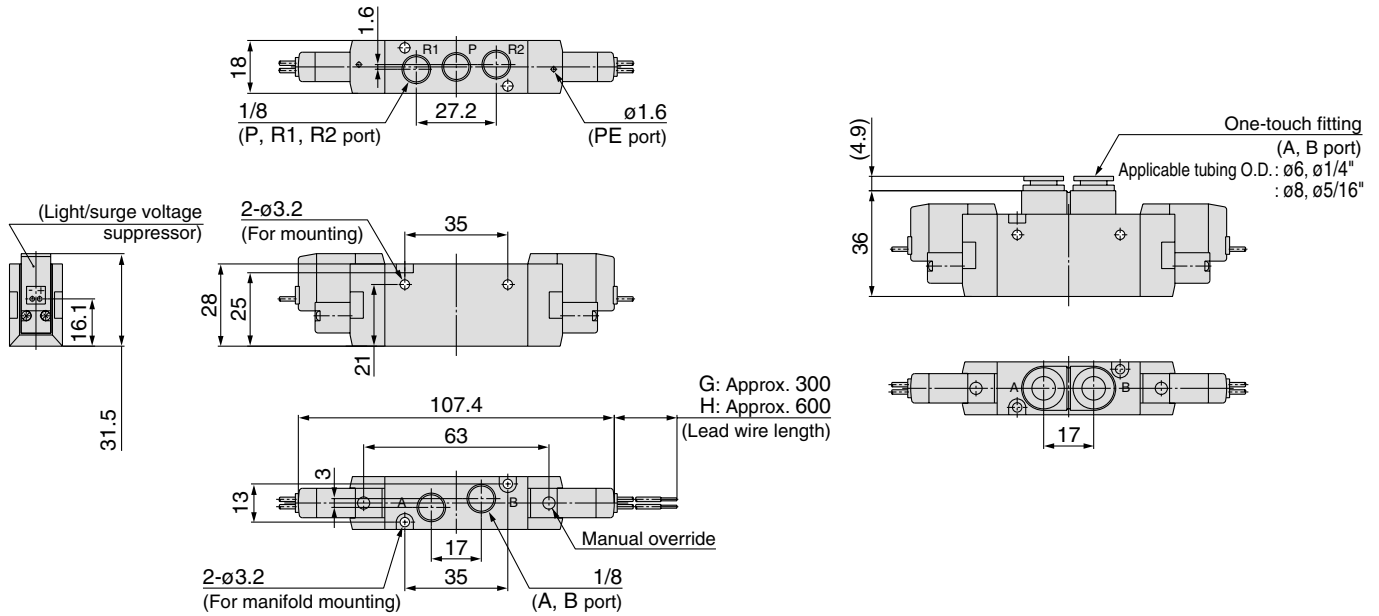

L plug connector (L):
SYJ7220-□L□□-01□-Q

M plug connector (M):
SYJ7220-□M□□-01□-Q

DIN terminal (D):
SYJ7220-□D□□-01□-Q

M8 connector (WO):
SYJ7220-□WO□□-01□-Q

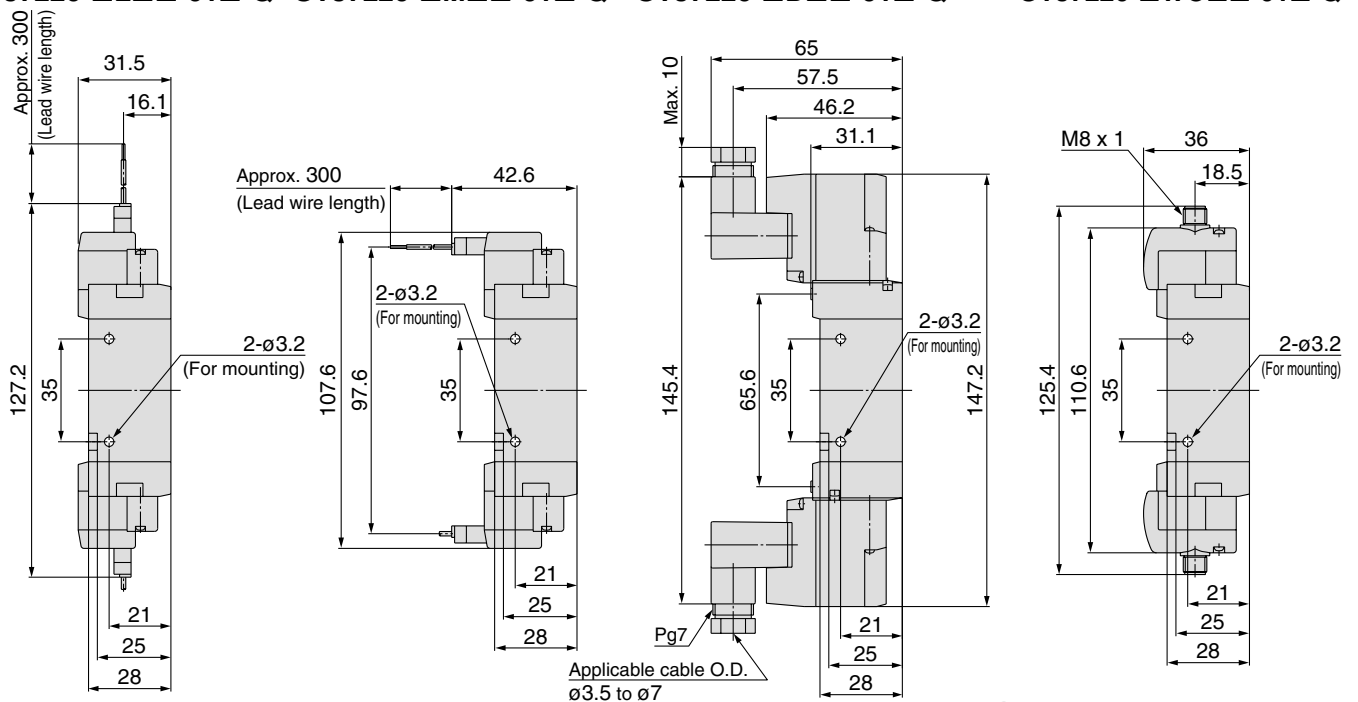

Refer to back page 11 for dimensions with connector cable.

3 Position Closed Center/Exhaust Center/Pressure Center

Grommet (G), (H): SYJ7 $\frac{3}{5}$ 20-□ $\frac{G}{H}$ □□-01□-Q

Built-in one-touch fitting:
SYJ7 $\frac{3}{5}$ 20-□ $\frac{G}{H}$ □□-C $\frac{6}{8}$, N $\frac{7}{9}$ □-Q

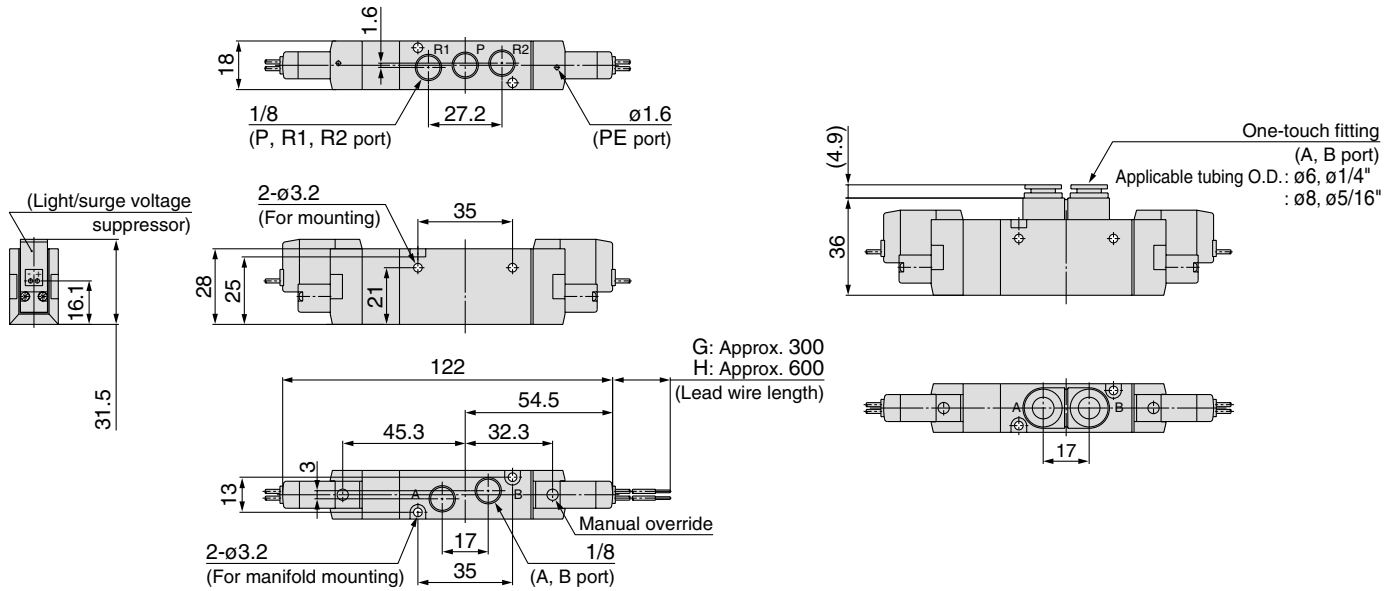

L plug connector (L):
SYJ7 $\frac{3}{5}$ 20-□L□□-01□-Q

M plug connector (M):
SYJ7 $\frac{3}{5}$ 20-□M□□-01□-Q

DIN terminal (D):
SYJ7 $\frac{3}{5}$ 20-□D□□-01□-Q

M8 connector (WO):
SYJ7 $\frac{3}{5}$ 20-□WO□□-01□-Q

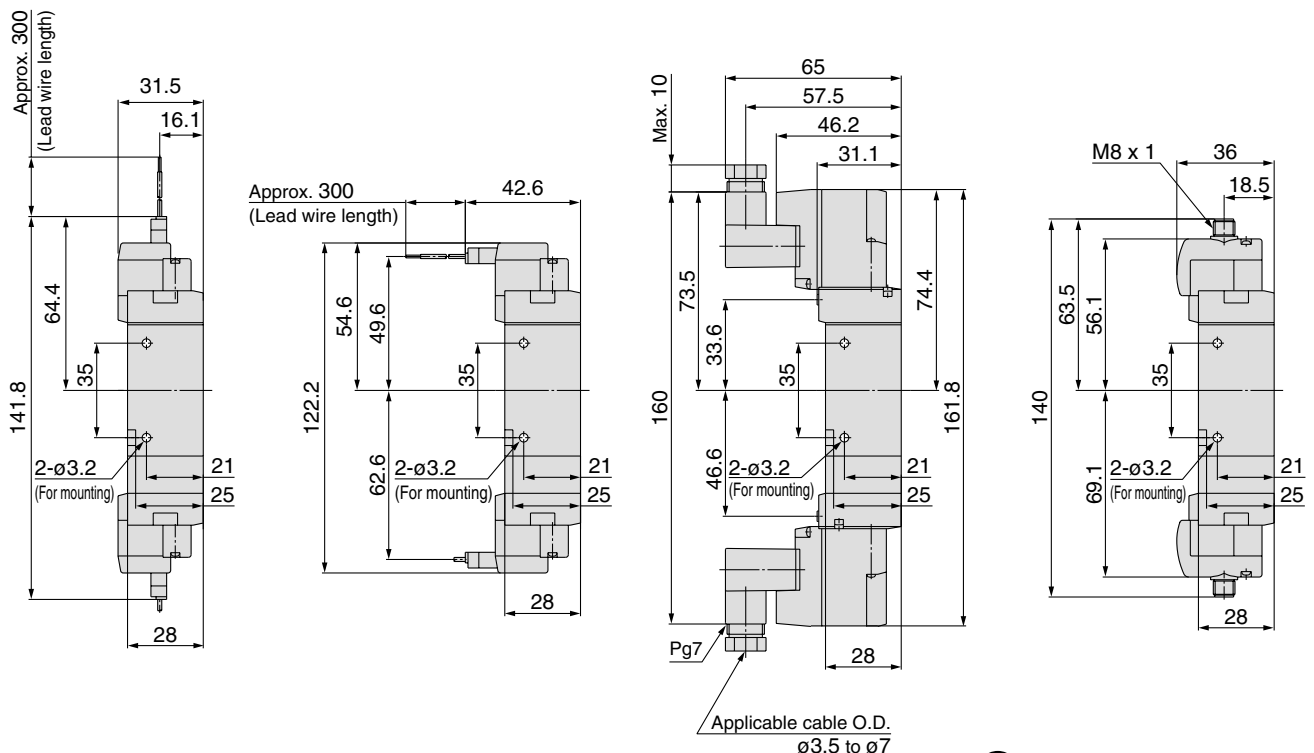

Refer to back page 11 for dimensions with connector cable.

Series SYJ7000

2 Position Single

Grommet (G), (H): SYJ7140-□□_H□□-01□□-Q

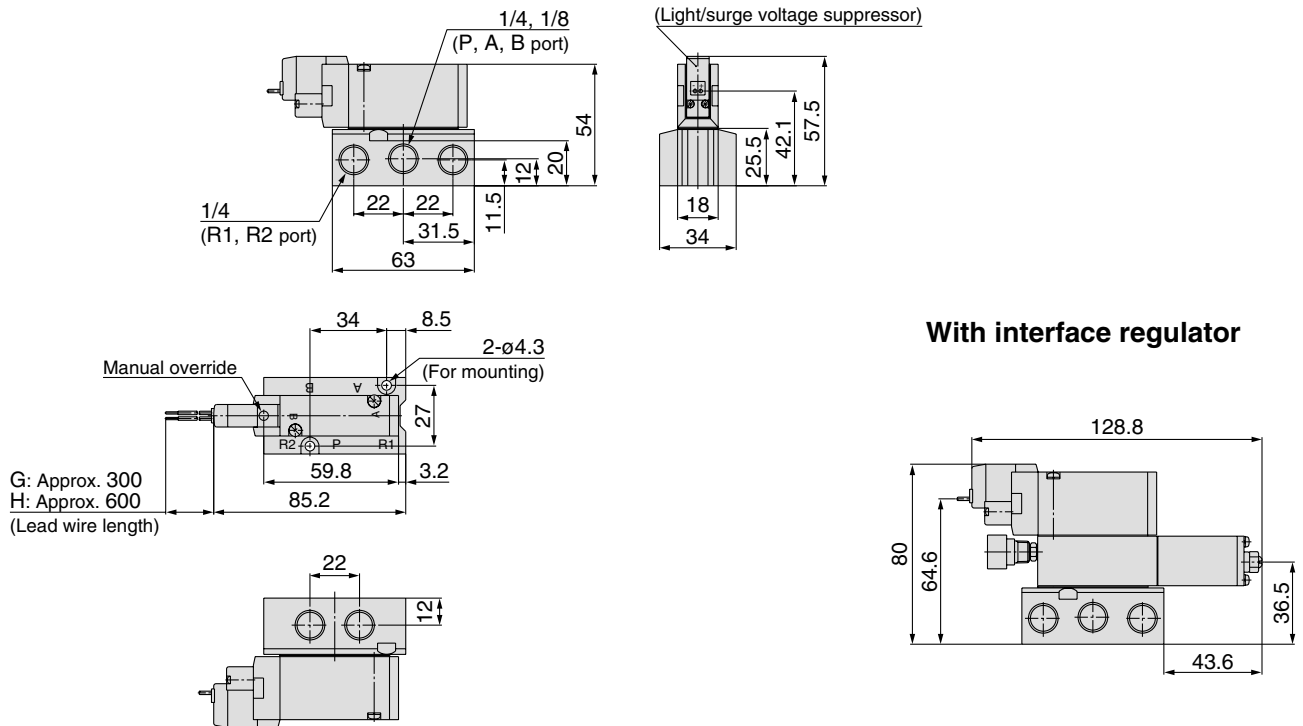

L plug connector (L):
SYJ7140-□L□□-01□□-Q

M plug connector (M):
SYJ7140-□M□□-01□□-Q

DIN terminal (D):
SYJ7140-□D□□-01□□-Q

M8 connector (WO):
SYJ7140-□WO□□-01□□-Q

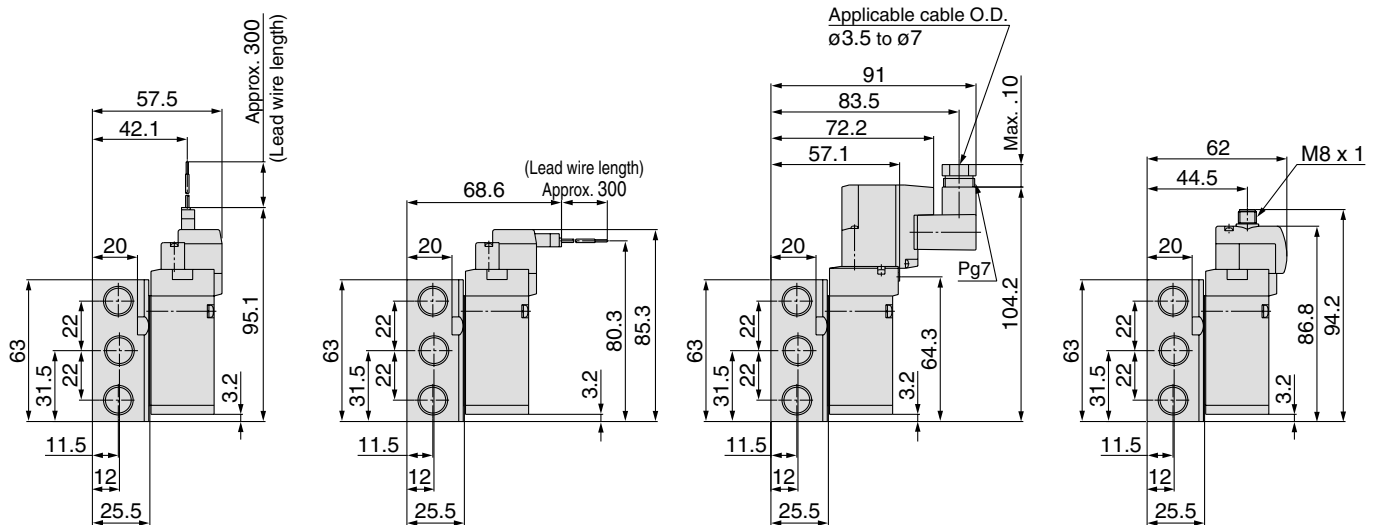

Refer to back page 11 for dimensions with connector cable.

2 Position Double

Grommet (G), (H): SYJ7240-□_G□□□-01□-Q

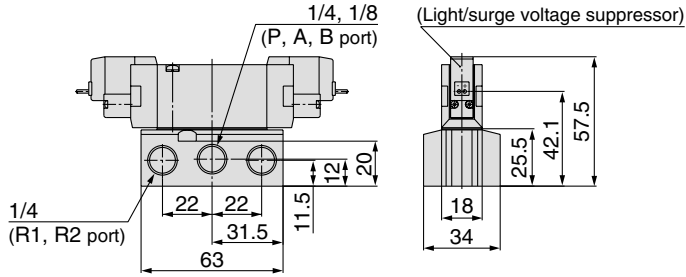

G: Approx. 300
H: Approx. 600
(Lead wire length)

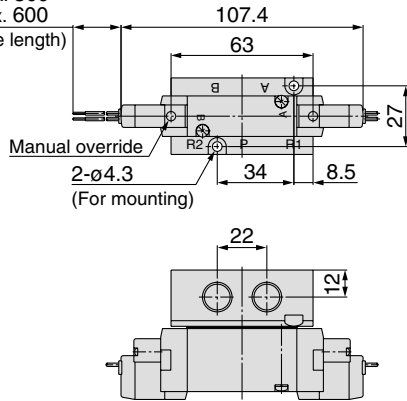

With interface regulator

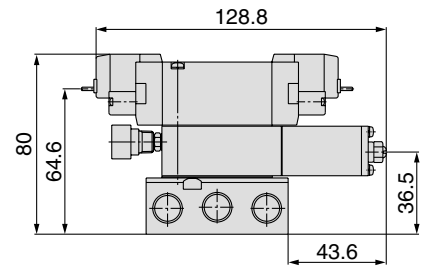

L plug connector (L):
SYJ7240-□L□□□-01□-Q

M plug connector (M):
SYJ7240-□M□□□-01□-Q

DIN terminal (D):
SYJ7240-□D□□□-01□-Q

M8 connector (WO):
SYJ7240-□WO□□□-01□-Q

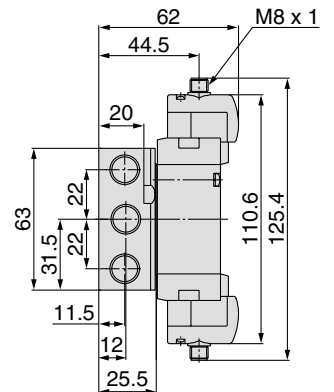
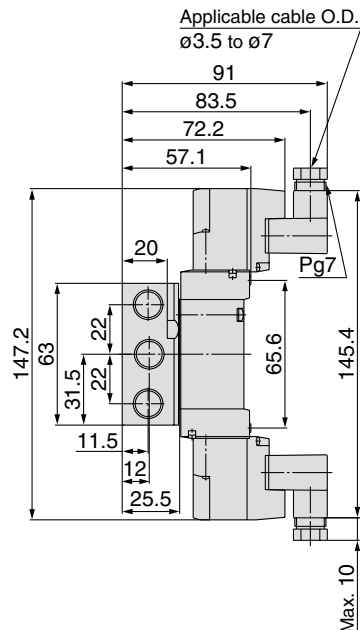
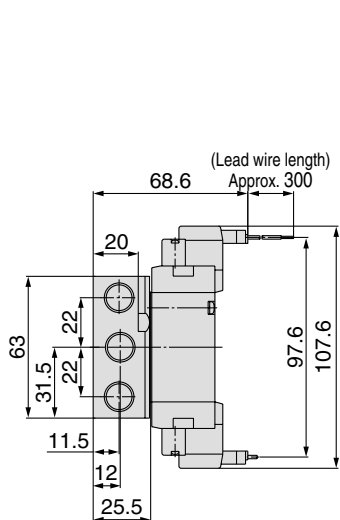
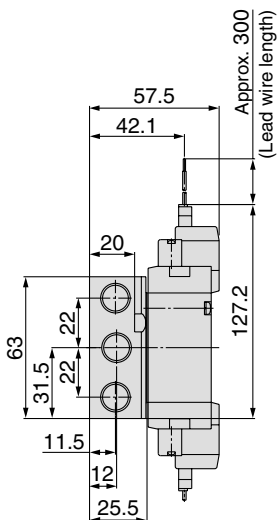

Refer to back page 11 for dimensions with connector cable.

Series SYJ7000

3 Position Closed Center/Exhaust Center/Pressure Center

Grommet (G), (H): SYJ7³/₅40-□_G□□-01□-Q

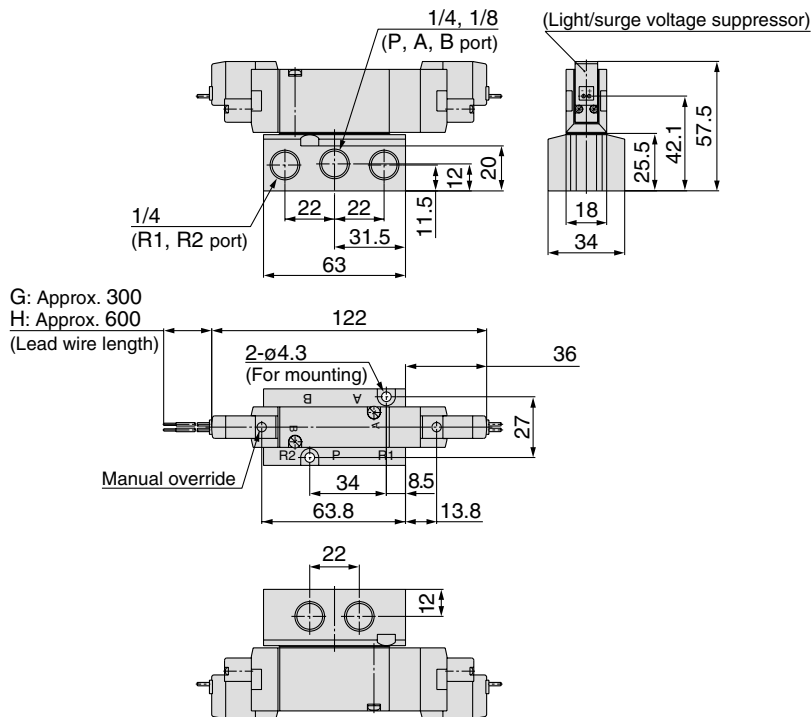

With interface regulator

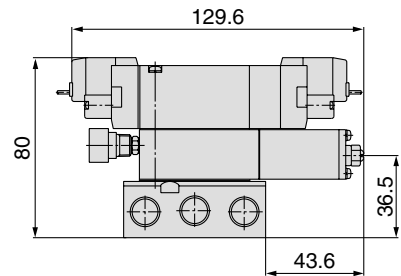

L plug connector (L):
SYJ7³/₅40-□L□□-01□-Q

M plug connector (M):
SYJ7³/₅40-□M□□-01□-Q

DIN terminal (D):
SYJ7³/₅40-□D□□-01□-Q

M8 connector (WO):
SYJ7³/₅40-□WO□□-01□-Q

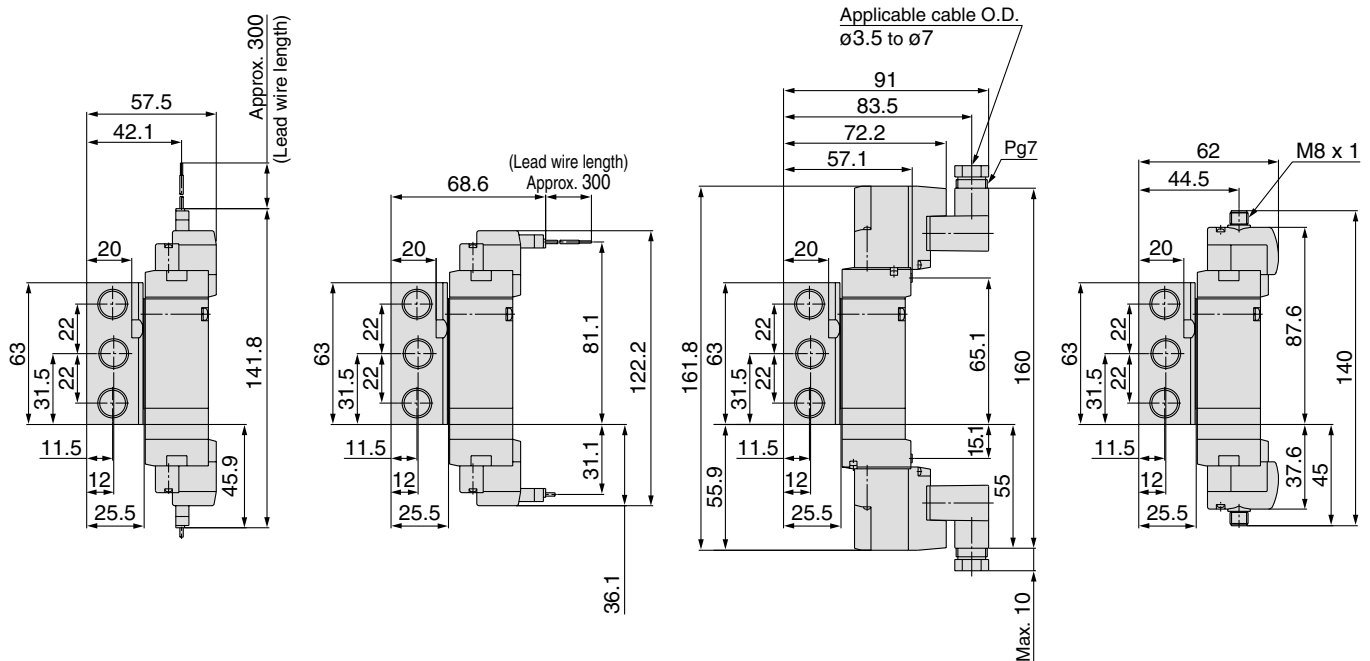

Refer to back page 11 for dimensions with connector cable.

Manifold Specifications



Manifold Standard

Manifold Specifications

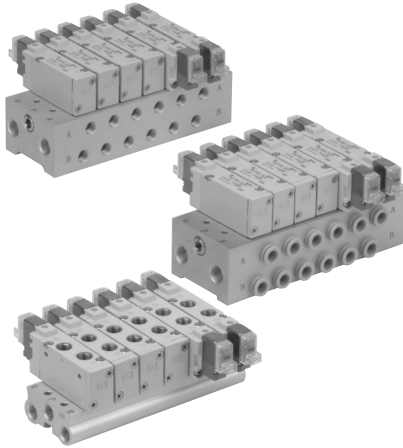

Model		Type 20	Type 21	Type 40	Type 20	Type 42
Manifold type		Single base/B mount				
P (SUP), R (EXH)		Common SUP, Common EXH				
Valve stations		2 to 15 stations		2 to 20 stations		
A, B port Porting specifications	Location	Valve		Base	Base	
	Direction	Top		Bottom	Side	
Port size	P, R port	1/8		1/4		
	A, B port	1/8 C6 (One-touch fitting for ø6) C8 (One-touch fitting for ø8)		1/8		C6 (One-touch fitting for ø6) C8 (One-touch fitting for ø8)

Flow Characteristics

Manifold		Port size		Flow characteristics								
				1→4/2 (P→A/B)				4/2→5/3 (A/B→R)				
		1(P), 5/3(R) Port	2(B), 4(A) Port	C [dm ³ /(s·bar)]	b	Cv	Q _l /min(ANR) [*]	C [dm ³ /(s·bar)]	b	Cv	Q _l /min(ANR) [*]	
Body ported for internal pilot	Type SS5YJ7-20	SYJ7□2□	1/8	1/8	2.2	0.35	0.57	578	2.3	0.26	0.55	571
			1/8	C6	1.4	0.32	0.37	361	2.0	0.25	0.49	493
	1/8		C8	1.7	0.38	0.45	456	2.1	0.25	0.51	518	
	1/4		1/8	2.1	0.36	0.55	555	2.3	0.26	0.54	571	
Base mounted for internal pilot	Type SS5YJ7-21	SYJ7□4□	1/4	C6	1.4	0.32	0.36	361	2.1	0.24	0.50	515
			1/4	C8	1.8	0.37	0.50	479	2.1	0.20	0.50	503
	Type SS5YJ7-40		1/4	1/8	2.1	0.28	0.51	527	2.5	0.23	0.59	609
			Type SS5YJ7-41	1/4	1/8	2.0	0.30	0.50	509	2.2	0.30	0.55
Type SS5YJ7-42-C6	1/4	C6	1.5	0.32	0.38	386	2.2	0.23	0.52	536		
	Type SS5YJ7-42-C8	1/4	C8	1.9	0.24	0.46	466	2.2	0.26	0.53	546	

Note) Value at manifold base mounted, 2 position single operating
 * These values have been calculated according to ISO6358 and represent the flow rate measured in standard conditions at an upstream of 0.6MPa (relative pressure) and a differential pressure of 0.1MPa.

How to Order Manifold (Example)

Instruct by specifying the valves and blanking plate assembly to be mounted on the manifold along with the manifold base model no.

Example: ●SS5YJ7-20-03-Q 1 pc. (Manifold base)
 * SYJ7120-5G-01-Q 2 pcs. (Valve)
 * SYJ7000-21-1A-Q 1 pc. (Blanking plate assembly)

●SS5YJ7-41-03-01-Q 1 pc. (Manifold base)
 * SYJ7140-5LZ-Q 1 pc. (Valve)
 * SYJ7240-5LZ-Q 1 pc. (Valve)
 * SYJ7000-21-1A-Q 1 pc. (Blanking plate assembly)

↳The asterisk denotes the symbol for assembly. Prefix it to the part nos. of the solenoid valve, etc.

* Use manifold specification sheet.

Flat Ribbon Cable Manifold

- Multiple valve wiring is simplified through the use of the flat cable connector.
- Clean appearance

In the case of a flat ribbon cable type, each valve is wired on the print board of manifold base to allow the external wiring to be piped all together with 26 pins MIL connector.

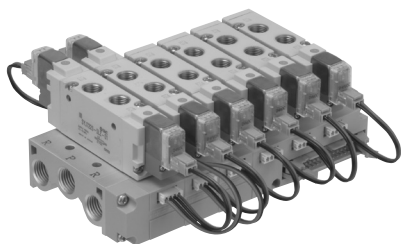

Flat Ribbon Cable Manifold Specifications

Model		Type 21P
Manifold type		Single base/B mount
P (SUP), R (EXH)		Common SUP, Common EXH
Valve stations		3 to 12 stations
A, B port location		Valve
Port size	P, R port	1/4
	A, B port	1/8, C6, C8
Applicable flat ribbon cable connector		Socket: 26 pins MIL type with strain relief (MIL-C-83503)
Internal wiring		In common between +COM and -COM (Z type: +COM only).
Rated voltage		24, 12 VDC

Note 1) The value is for manifold base and individually operated 2 position type.
 Note 2) The withstand voltage specification for the wiring unit section is JIS C 0704, Grade 1 or its equivalent.

Flow Characteristics

Manifold	Port size	Flow characteristics									
		1→4/2 (P→A/B)				4/2→5/3 (A/B→R)					
		1(P), 5/3(R) Port	2(B), 4(A) Port	C [dm ³ /(s·bar)]	b	Cv	Q [l/min(ANR)]*	C [dm ³ /(s·bar)]	b	Cv	Q [l/min(ANR)]*
Body ported for internal pilot	Type SS5YJ7-21P-01	1/4	1/8	2.1	0.36	0.55	555	2.3	0.26	0.54	571
	Type SS5YJ7-21P-C6	1/4	C6	1.4	0.32	0.36	361	2.1	0.24	0.50	515
	Type SS5YJ7-21P-C8	1/4	C8	1.8	0.37	0.50	479	2.1	0.20	0.50	503

Note) Value at manifold base mounted, 2 position single operating
 * These values have been calculated according to ISO6358 and represent the flow rate measured in standard conditions at an upstream of 0.6MPa (relative pressure) and a differential pressure of 0.1MPa.

How to Order Manifold (Example)

Instruct by specifying the valves, blanking plate assembly and connector assembly to be mounted on the manifold along with the manifold base model no.

Example: **SS5YJ7-21P-07-Q** 1 pc. (Manifold base)
 * **SYJ7123-5LOU-C8-Q** 3 pcs. (Valve)
 * **SYJ7223-5LOU-C8-Q** 3 pcs. (Valve)
 * **SYJ7000-21-3A-Q** 1 pc. (Blanking plate assembly)
 * **SY3000-37-3A** 3 pcs. (Connector assembly)
 * **SY3000-37-4A** 3 pcs. (Connector assembly)
 ↳The asterisk denotes the symbol for assembly. Prefix it to the part nos. of the solenoid valve, etc.

* Use manifold specification sheet.



How to Order Valve

How to Order Connector Assembly

For 12, 24 VDC

Single solenoid	SY3000-37-3A
Double solenoid, 3 position type	SY3000-37-4A
Single solenoid, individual SUP, EXH spacer	SY3000-37-3A
Double solenoid, 3 position individual SUP/EXH spacer	SY3000-37-6A
Interface regulator for single solenoid	SY3000-37-3A
Double solenoid, 3 position interface regulator	SY3000-37-6A
3 port adaptor plate	SY3000-37-3A

For DC SYJ7 **1** 23 — **5** LO **Z** — **01** — Q

Rated voltage

5	24 VDC
6	12 VDC

Light/surge voltage suppressor

Z	With light/surge voltage suppressor
U	With light/surge voltage suppressor (Non-polar type)

Note) Z: Positive common specifications only.

Type of actuation

1	2 position single
2	2 position double
3	3 position closed center
4	3 position exhaust center
5	3 position pressure center

Manual override

-	Non-locking push type
D	Push-turn locking slotted type
E	Push-turn locking lever type

A, B port size

Symbol	Port size
01	1/8
C6	One-touch fitting for ø6
C8	One-touch fitting for ø8
N7	One-touch fitting for ø1/4"
N9	One-touch fitting for ø5/16"

Flat Ribbon Cable Connector

AXT100-FC26-¹/₂/₃

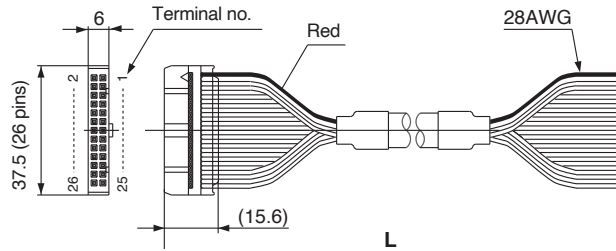

Flat ribbon cable connector

Cable length (L)	Assembly part no.
	26 pins
1.5 m	AXT100-FC26-1
3 m	AXT100-FC26-2
5 m	AXT100-FC26-3

- * When using a standard commercial connector, use a 26-pin type connector conforming to MIL-C-83503 with strain relief.
- * Cannot be used for movable wiring
- * Lengths other than the above are also available. Please contact SMC for details.

Connector Manufacturer's Example

- HIROSE ELECTRIC CO., LTD.
- 3M Japan Limited
- Fujitsu Limited
- Japan Aviation Electronics Industry, Limited
- J.S.T. Mfg. Co., Ltd.
- Oki Electric Cable Co., Ltd.

Specified Layout

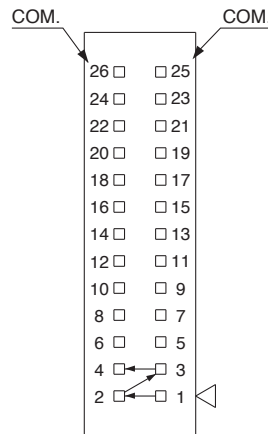

(P: 26 pins)

A mixture of single and double wiring can be specified on the manifold specification sheet. The maximum number of stations is determined according to the number of solenoids. The total number of solenoids should be 24 or less for P and PC. 1 solenoid is required for the 2-position single, and 2 solenoids for the 2-position double, and 3-position.

Manifold Standard /Common SUP/Common EXH

Type 20 (5 Port/Body ported)

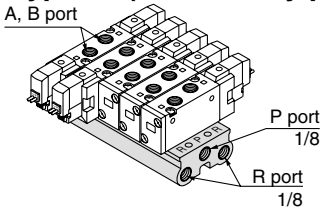

How to Order

SS5YJ7-20-05-□-Q

Stations	
02	2 stations
:	:
15	15 stations

P, R port
thread type

-	Rc
00F	G
00N	NPT
00T	NPTF

Applicable solenoid valve

SYJ□20-□□□□-C6-Q⁰¹
C8
SYJ□23-□□□□-C6-Q⁰¹
C8

Note) For more than 6 stations, supply air to both sides of P port and exhaust air from both sides of R port.

Type 21 (5 Port/Body ported)

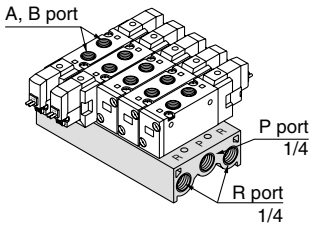

How to Order

SS5YJ7-21-05-□-Q

Stations	
02	2 stations
:	:
20	20 stations

P, R port
thread type

-	Rc
00F	G
00N	NPT
00T	NPTF

Applicable blanking
plate assembly

SYJ7000-21-1A-1-Q

Applicable individual
EXH spacer assembly

SYJ7000-17-1A-Q

Note) For more than 10 stations, supply air to both sides of P port and exhaust air from both sides of R port.

Type 40 (5 Port/Base mounted)

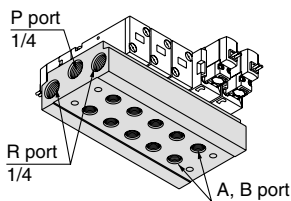

How to Order

SS5YJ7-40-05-01-□-Q

Stations	
02	2 stations
:	:
20	20 stations

A, B port size

01	1/8
----	-----

Thread type

-	Rc
F	G
N	NPT
T	NPTF

Applicable solenoid valve

SYJ□40-□□□□-Q
SYJ□43-□□□□-Q

Note) For more than 10 stations, supply air to both sides of P port and exhaust air from both sides of R port.

Type 41 (5 Port/Base mounted)

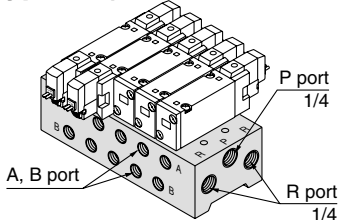

How to Order

SS5YJ7-41-05-01-□-Q

Stations	
02	2 stations
:	:
20	20 stations

A, B port size

01	1/8
----	-----

Thread type

-	Rc
F	G
N	NPT
T	NPTF

Applicable blanking
plate assembly

SYJ7000-21-1A-2-Q

Applicable individual
EXH spacer assembly

SYJ7000-17-2A-Q

Note) For more than 8 stations, supply air to both sides of P port and exhaust air from both sides of R port.

Type 42 (5 Port/Base mounted)

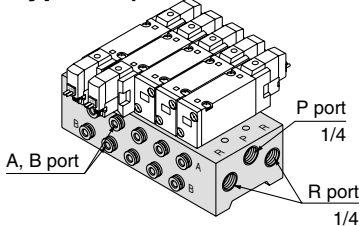

How to Order

SS5YJ7-42-05-C6-□-Q

Stations	
02	2 stations
:	:
20	20 stations

A, B port size

C6	One-touch fitting for ø6
C8	One-touch fitting for ø8
N7	One-touch fitting for ø1/4"
N9	One-touch fitting for ø5/16"

Thread type

-	Rc
F	G
N	NPT
T	NPTF

Applicable individual
SUP spacer assembly

SYJ7000-16-2A-Q

Applicable interface
regulator

ARBYJ7000-00-P-Q

Note) For more than 8 stations, supply air to both sides of P port and exhaust air from both sides of R port.

Flat Ribbon Cable Manifold /Common SUP/Common EXH

Type 21P (5 Port/Body ported)

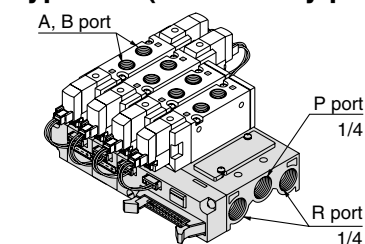

How to Order

SS5YJ7-21P-05-□-Q

Stations	
03	3 stations
:	:
12	12 stations

P, R port
thread type

-	Rc
00F	G
00N	NPT
00T	NPTF

Applicable solenoid valve
Refer to page 59.

Applicable blanking
plate assembly

SYJ7000-21-3A-Q

Applicable connector
assembly

Refer to page 59.

Note) For more than 10 stations, supply air to both sides of P port and exhaust air from both sides of R port.

Series SYJ7000

Combinations of Solenoid Valve, Manifold Gasket and Manifold Base

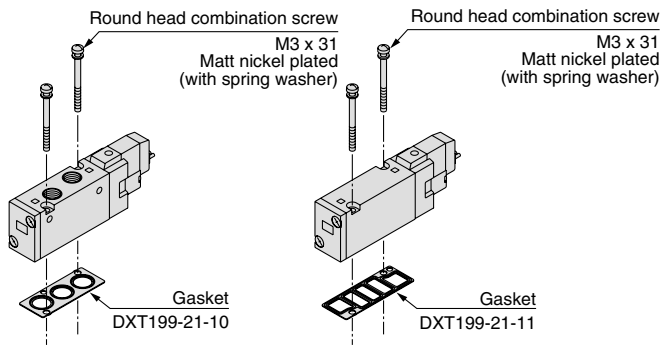

Applicable manifold base
Type SS5YJ7-20-Q
Type SS5YJ7-21-Q

Applicable manifold base Sub-plate
Type SS5YJ7-40-Q
Type SS5YJ7-41-Q
Type SS5YJ7-42-Q

Mix Installation of the SYJ700 and the SYJ7000 Valves on the Same Manifold

- Use of an adapter plate makes it possible to mount Series SYJ700 on the manifold bases of series SYJ7000.
- When mounting the SYJ700 valve on the SYJ7000 manifold, the SYJ700 solenoid must be positioned on the same side of the manifold as a single solenoid SYJ700. (Refer to the figure below.)
- For base mounted style, the A port of the 3 port valve flows out the B port of manifold base.

Adapter plate assembly SYJ700-3-1A-Q

SYJ700
Series
Body ported

Adapter plate assembly SYJ700-3-2A-Q

SYJ700
Series
Base mounted

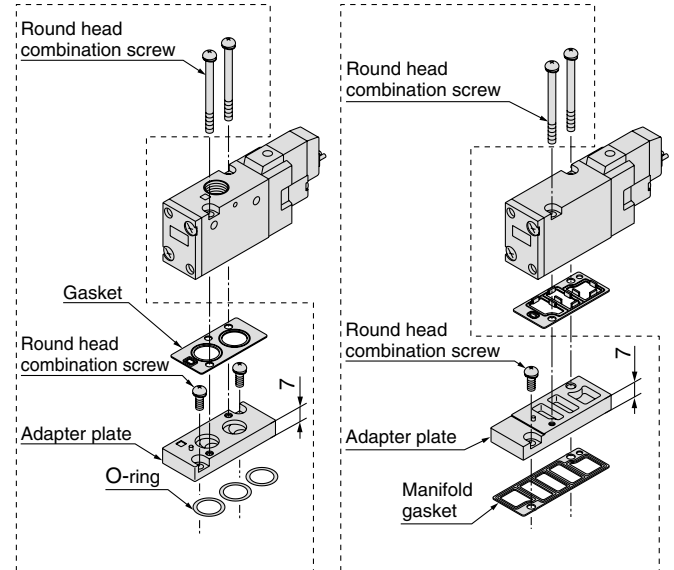

Applicable manifold base
Type SS5YJ7-20
Type SS5YJ7-21

Applicable manifold base
Type SS5YJ7-40
Type SS5YJ7-41
Type SS5YJ7-42

Individual EXH Spacer Assembly

SYJ7000-17-1 □ A-Q

Thread type

-	Rc
F	G
N	NPT
T	NPTF

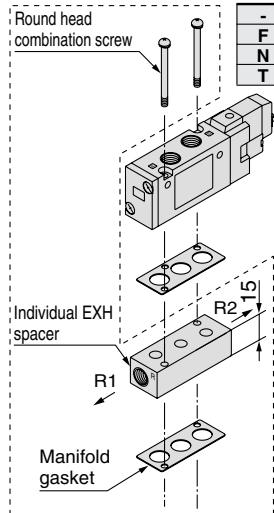

Applicable manifold base
Type SS5YJ7-20-Q
Type SS5YJ7-21-Q

SYJ7000-17-2 □ A-Q

Thread type

-	Rc
F	G
N	NPT
T	NPTF

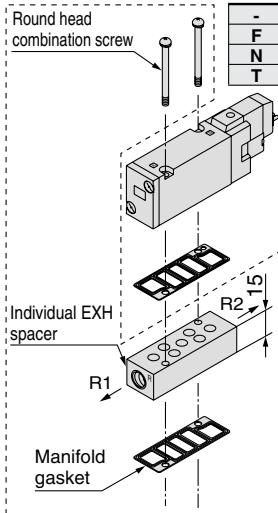

Applicable manifold base
Type SS5YJ7-40-Q
Type SS5YJ7-41-Q
Type SS5YJ7-42-Q

Individual SUP Spacer Assembly

SYJ7000-16-2 □ A-Q

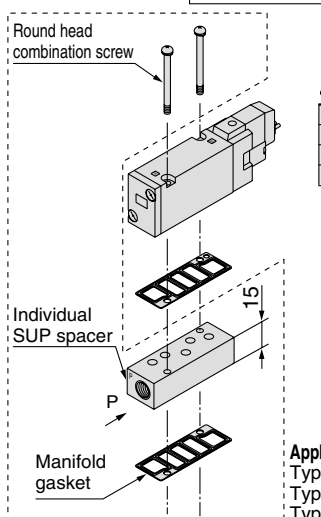

Thread type

-	Rc
F	G
N	NPT
T	NPTF

Applicable manifold base
Type SS5YJ7-40-Q
Type SS5YJ7-41-Q
Type SS5YJ7-42-Q

Interface Regulator (P port regulation)

Spacer type regulating valve on manifold block can regulate the pressure to the valve individually.

ARBYJ7000-00-P-Q

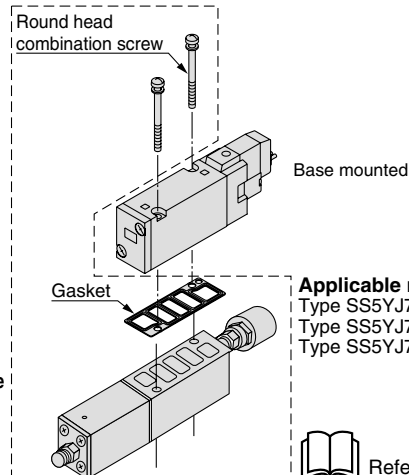

Applicable manifold base
Type SS5YJ7-40-Q
Type SS5YJ7-41-Q
Type SS5YJ7-42-Q

Blanking Plate Assembly

SYJ7000-21-1A-1-Q

SYJ7000-21-1A-2-Q

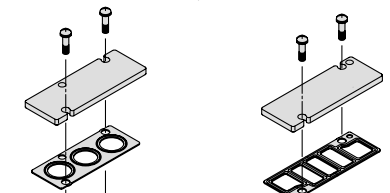

Applicable manifold base
Type SS5YJ7-20-Q
Type SS5YJ7-21-Q

Applicable manifold base
Type SS5YJ7-40-Q
Type SS5YJ7-41-Q
Type SS5YJ7-42-Q

SYJ7000-21-3A-Q

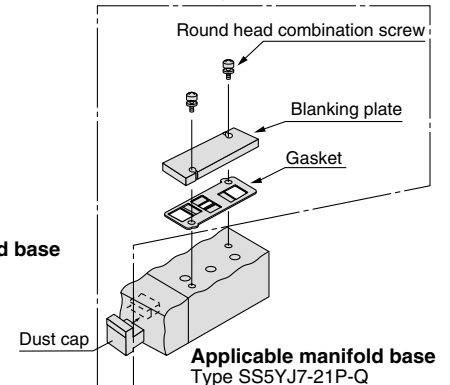

Applicable manifold base
Type SS5YJ7-21P-Q

Caution

Mounting screw tightening torques

M3: 0.8 N·m

Use caution to the assembly orientation for solenoid valves, gasket, and optional parts.



Refer to back page 12 prior to handling.

Type 20: Top Protod/SS5YJ7-20- Stations -00□-Q

Grommet (G)

Built-in one-touch fitting

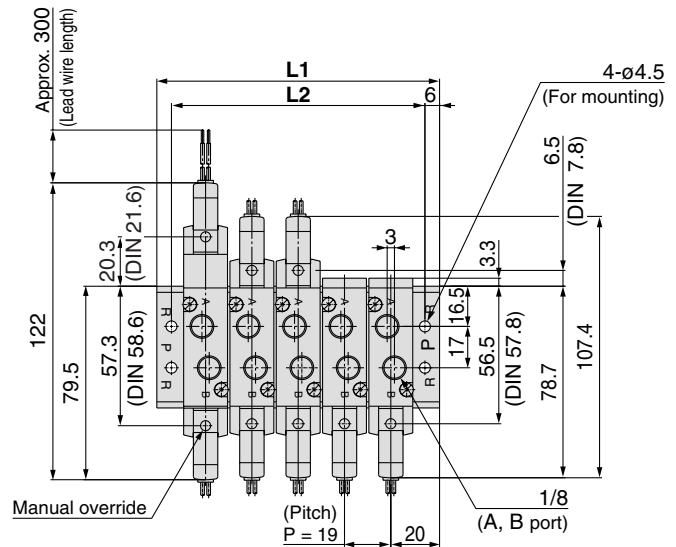
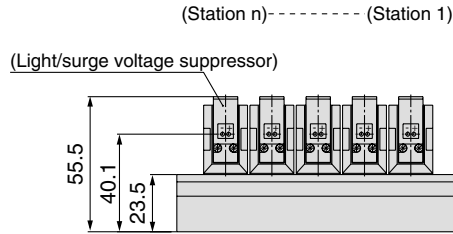
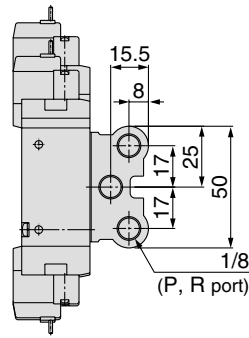
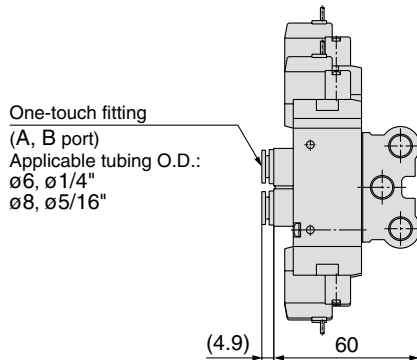

L plug connector (L)

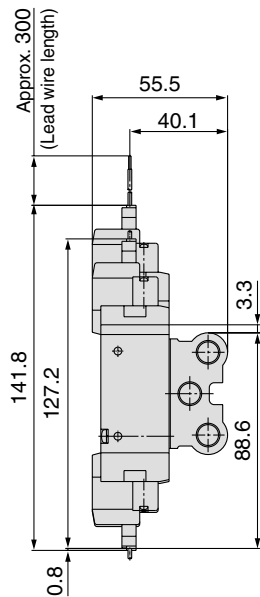

M plug connector (M)

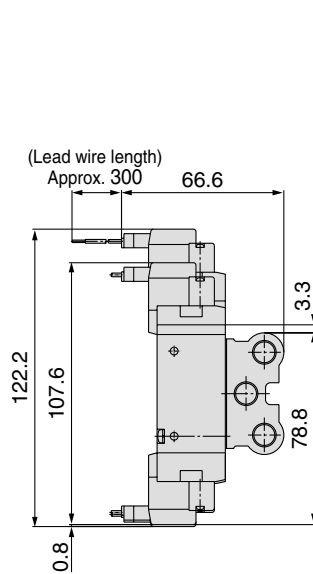

DIN terminal (D)

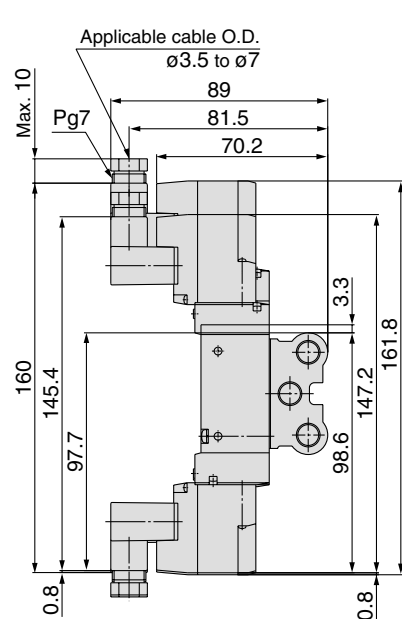

M8 connector (WO)

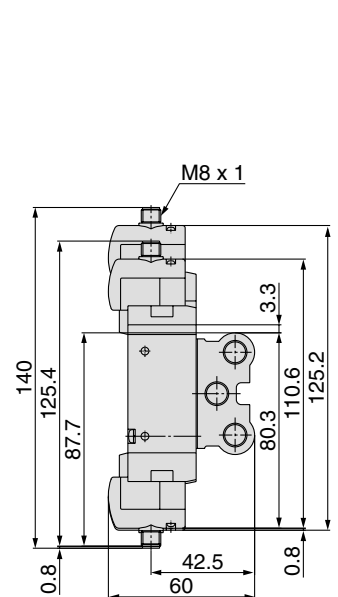

Refer to back page 11 for dimensions with connector cable.

Station n	Station 2	3	4	5	6	7	8	9	10	11	12	13	14	Station 15
L1	59	78	97	116	135	154	173	192	211	230	249	268	287	306
L2	47	66	85	104	123	142	161	180	199	218	237	256	275	294

Series SYJ7000

Type 21: Top Ported/SS5YJ7-21- Stations (-00□)-Q

Grommet (G)

Built-in one-touch fitting

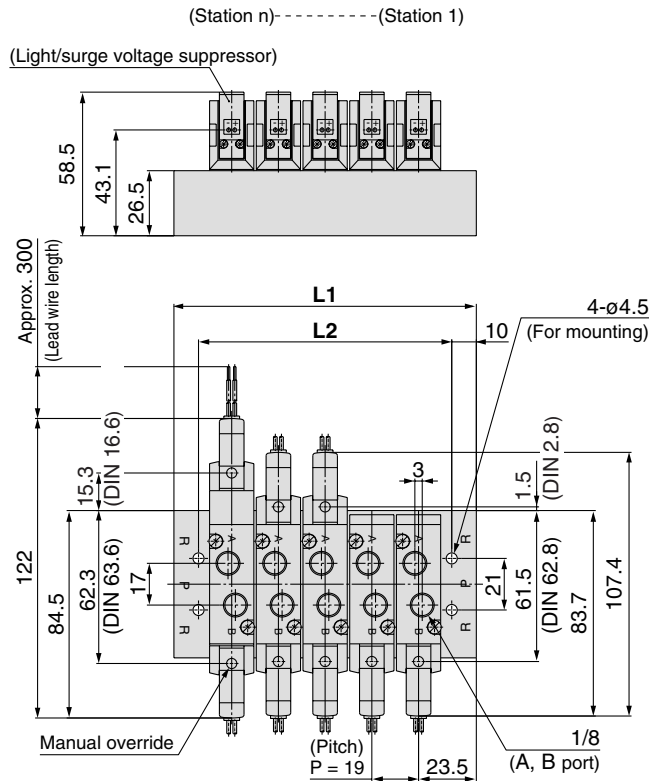
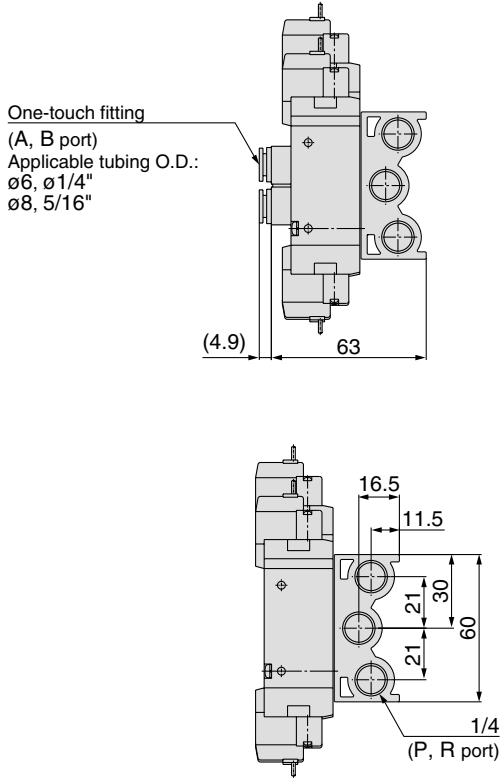

L plug connector (L)

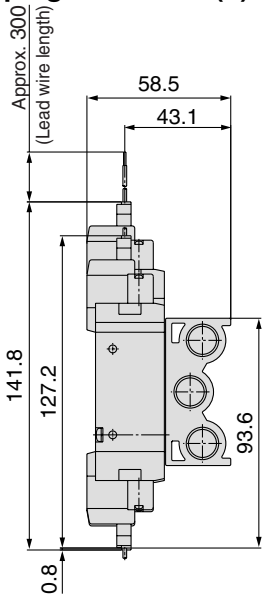

M plug connector (M)

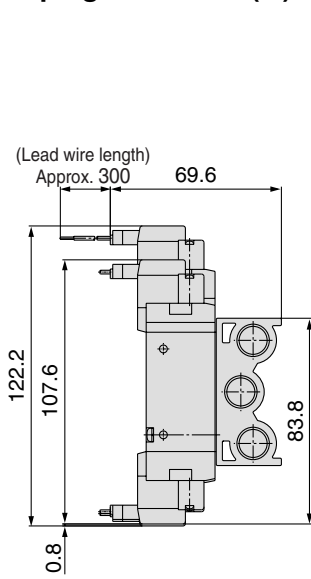

DIN terminal (D)

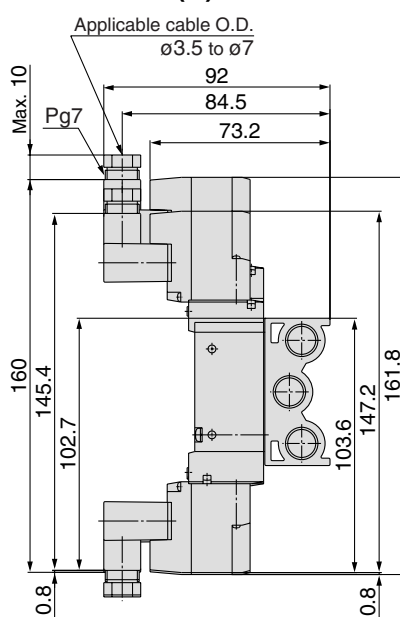

M8 connector (WO)

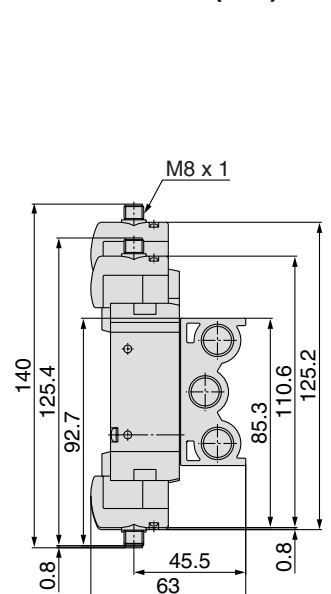

Refer to back page 11 for dimensions with connector cable.

Station n	Station 2	3	4	5	6	7	8	9	10	11	12	13	14	15	16	17	18	19	Station 20
L1	66	85	104	123	142	161	180	199	218	237	256	275	294	313	332	351	370	389	408
L2	46	65	84	103	122	141	160	179	198	217	236	255	274	293	312	331	350	369	388

Type 40: Bottom Ported/SS5YJ7-40- Stations -01□-Q

Grommet (G)

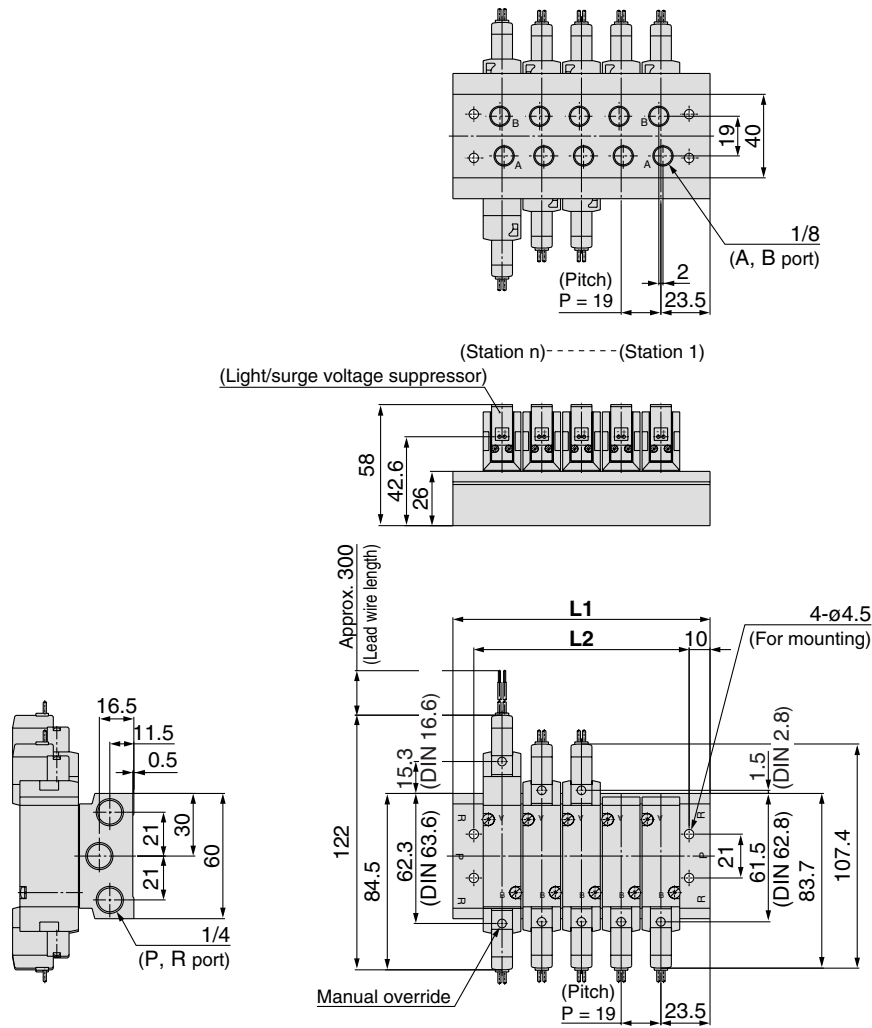

L plug connector (L)

M plug connector (M)

DIN terminal (D)

M8 connector (WO)

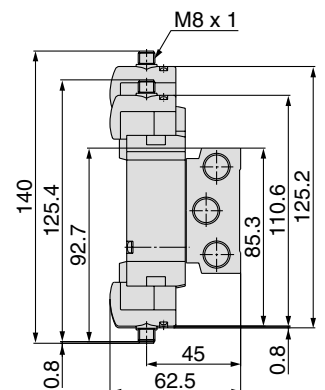
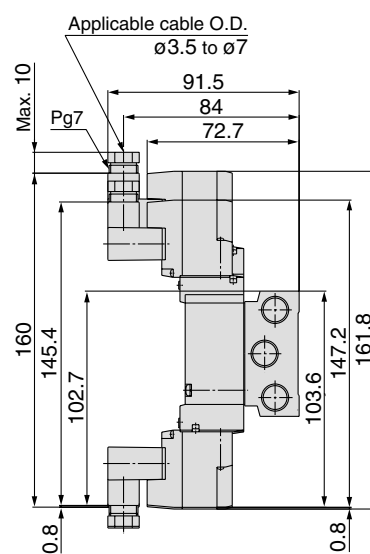
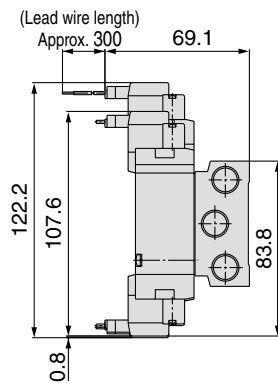
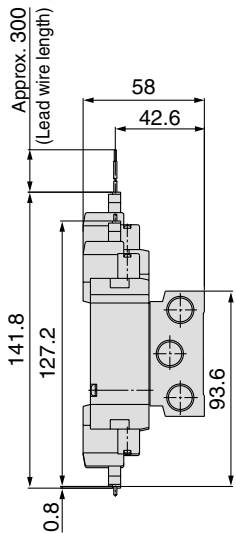

Refer to back page 11 for dimensions with connector cable.

Station n	Station 2	3	4	5	6	7	8	9	10	11	12	13	14	15	16	17	18	19	Station 20
L1	66	85	104	123	142	161	180	199	218	237	256	275	294	313	332	351	370	389	408
L2	46	65	84	103	122	141	160	179	198	217	236	255	274	293	312	331	350	369	388

Series SYJ7000

Type 41: Side Ported/SS5YJ7-41- Stations -01□-Q

Grommet (G)

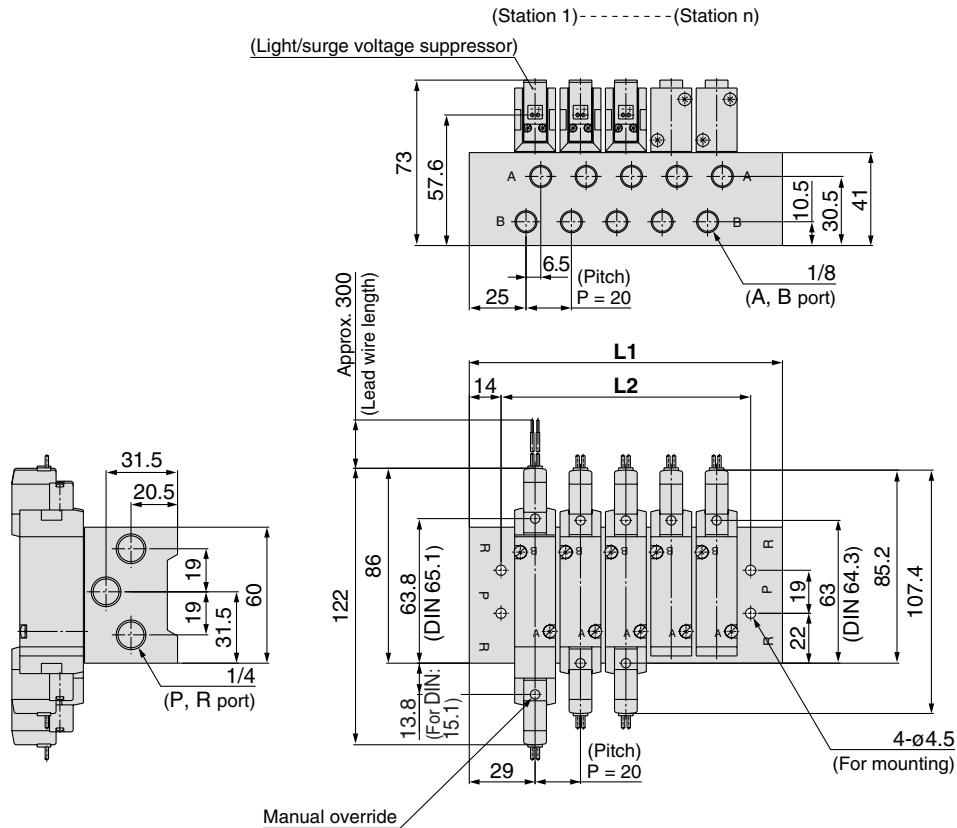

L plug connector (L)

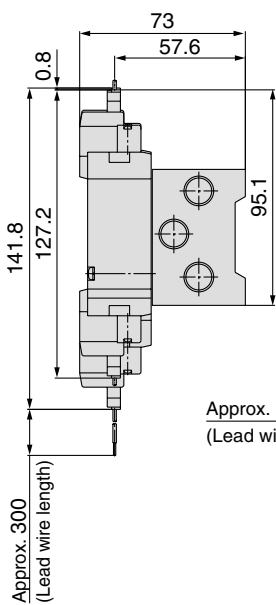

M plug connector (M)

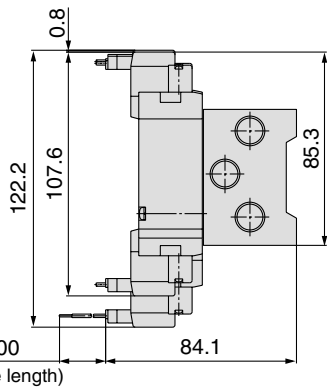

DIN terminal (D)

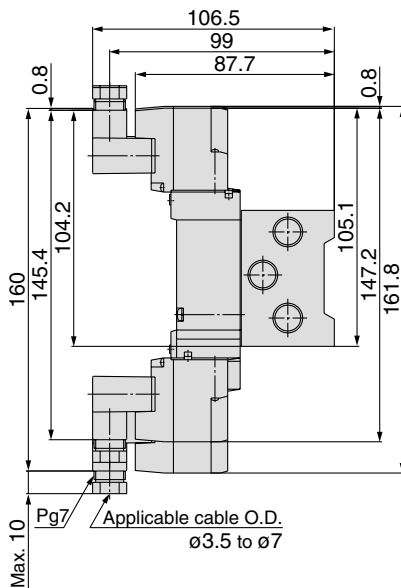

M8 connector (WO)

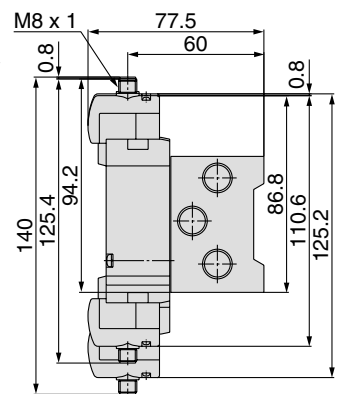

Refer to back page 11 for dimensions with connector cable.

Station n	Station 2	3	4	5	6	7	8	9	10	11	12	13	14	15	16	17	18	19	Station 20
L1	78	98	118	138	158	178	198	218	238	258	278	298	318	338	358	378	398	418	438
L2	50	70	90	110	130	150	170	190	210	230	250	270	290	310	330	350	370	390	410

Type 42: Side Ported/SS5YJ7-42- Stations - C6,N7 C8,N9 □-Q

Grommet (G)

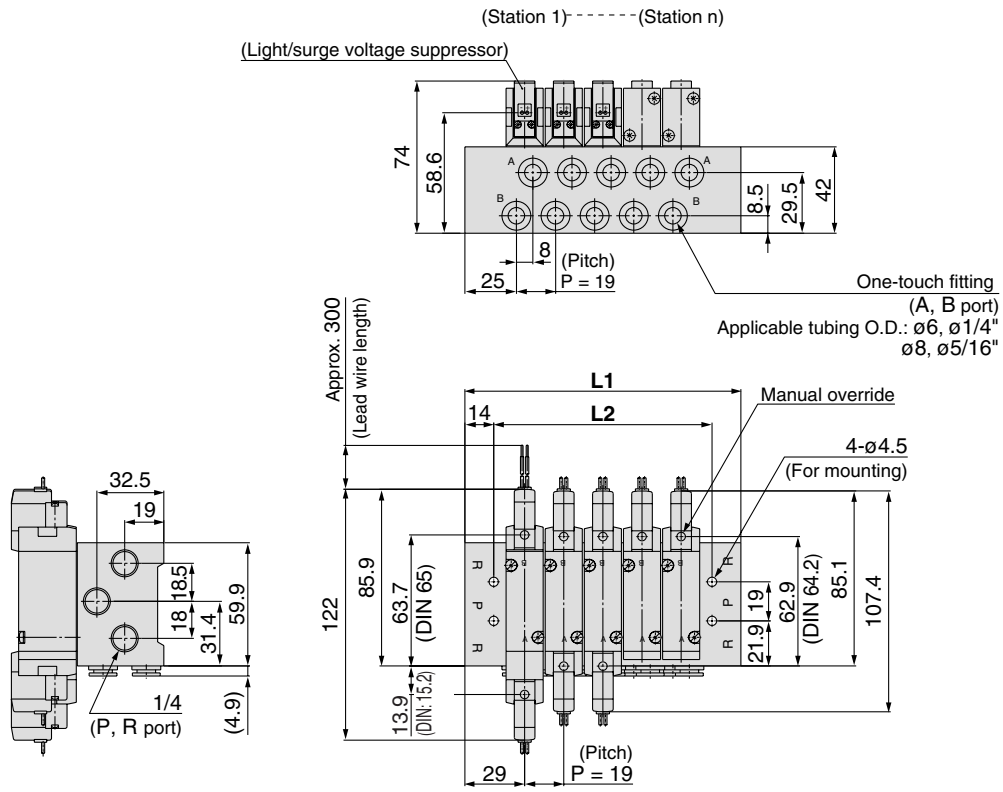

L plug connector (L)

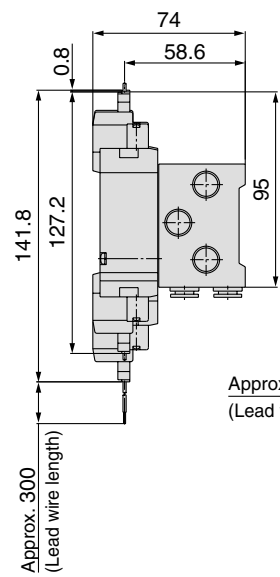

M plug connector (M)

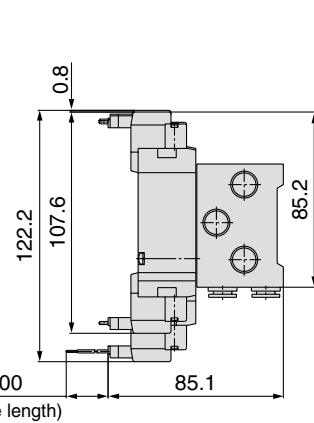

DIN terminal (D)

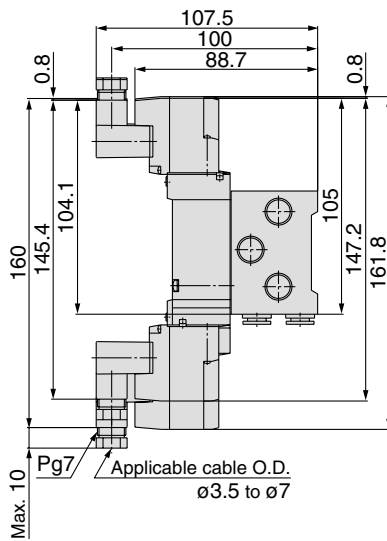

M8 connector (WO)

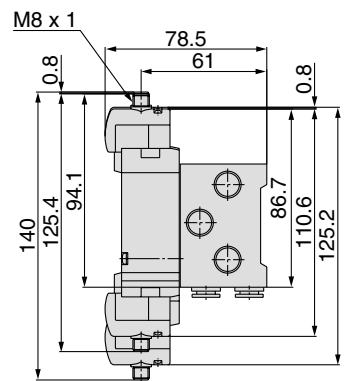

Refer to back page 11 for dimensions with connector cable.

Station n	Station 2	3	4	5	6	7	8	9	10	11	12	13	14	15	16	17	18	19	Station 20
L1	77	96	115	134	153	172	191	210	229	248	267	286	305	324	343	362	381	400	419
L2	49	68	87	106	125	144	163	182	201	220	239	258	277	296	315	334	353	372	391

Series SYJ7000

Flat Ribbon Cable Manifold

SS5YJ7-21P- Stations (-00□)-Q

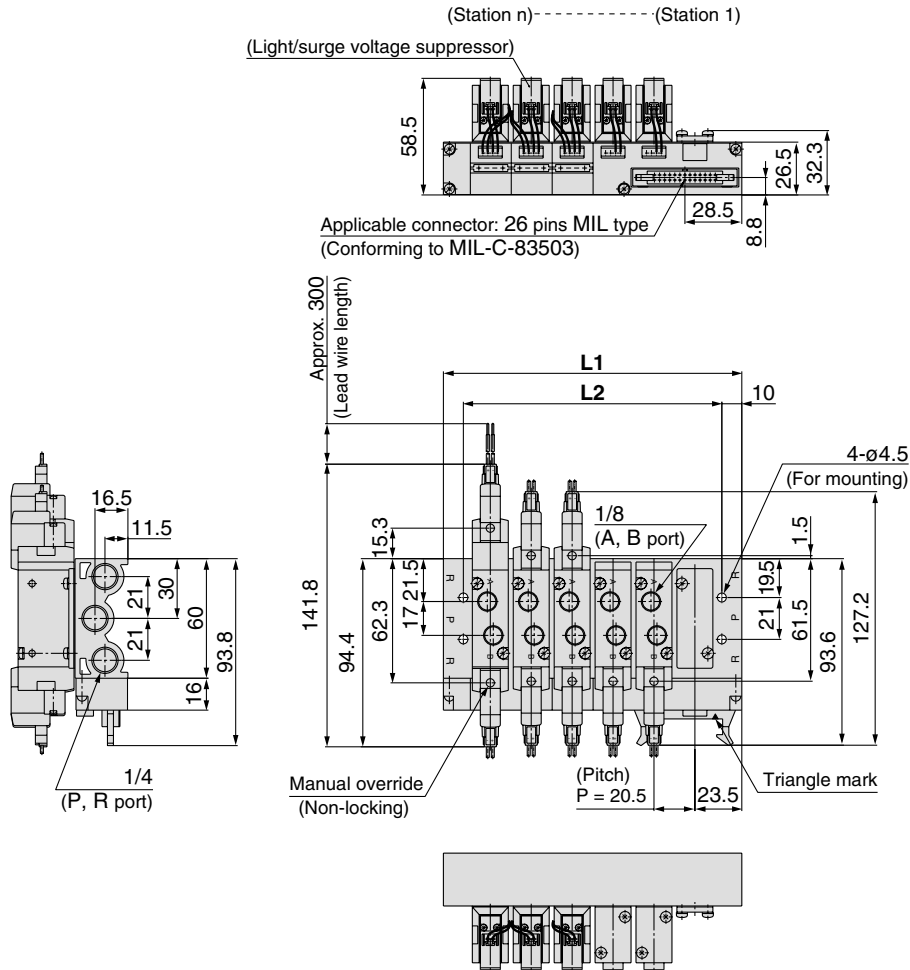

For built-in one-touch fitting

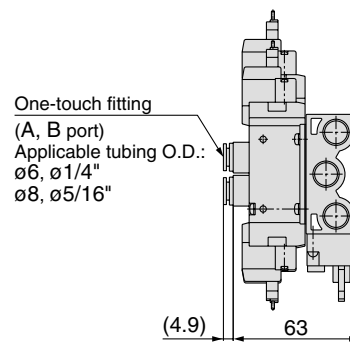

Station n	Station 3	4	5	6	7	8	9	10	11	Station 12
L1	88	108.5	129	149.5	170	190.5	211	231.5	252	272.5
L2	68	88.5	109	129.5	150	170.5	191	211.5	232	252.5

4/5 Port Air Operated Valve

Series SYJA3000

How to Order

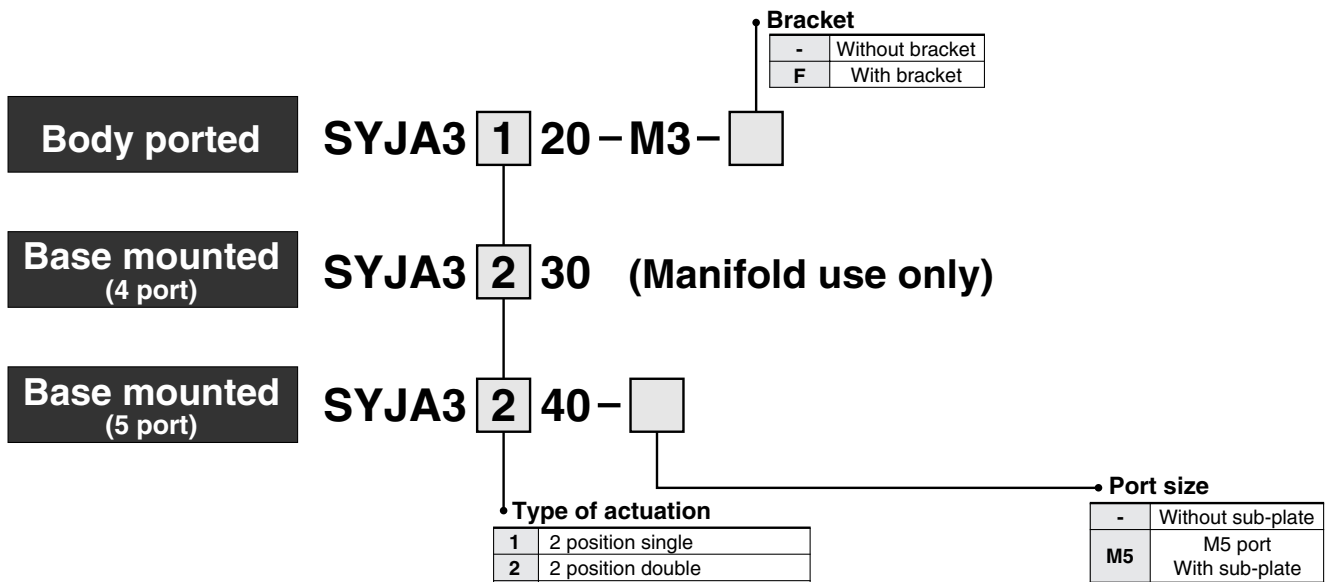

JIS Symbol

5 port

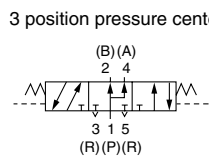
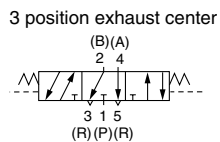
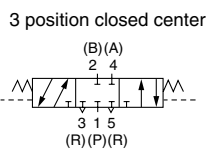
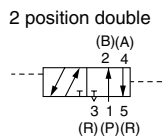
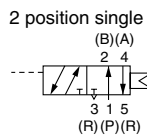

4 port

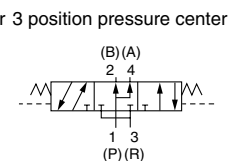
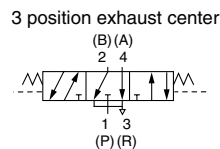
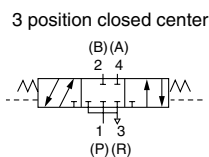
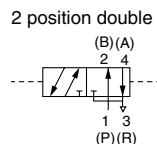
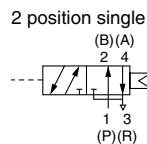

How to Order Manifold Base

Same manifolds as series SYJ3000 are prepared.

SS5YJA3 - Fill the same as SS5YJ3

Instruct by specifying the valves and blanking plate assembly to be mounted on the manifold along with the manifold base model no.

(Example)

SS5YJA3-41-03-M5 1 pc.
 *SYJA3140 1 pc.
 *SYJA3240 1 pc.
 *SYJ3000-21-2A 1 pc.

↳ The asterisk denotes the symbol for assembly. Prefix it to the part nos. of the solenoid valve, etc.

⚠ Caution

Refer to back page 1 through to 5 for Safety Instructions and Common Precautions.

Specifications

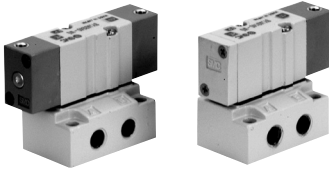

Base mounted

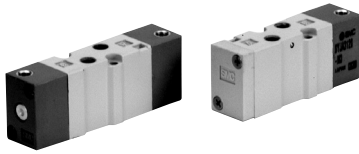

Body ported

Fluid		Air
Operating pressure range (MPa)	2 position single	0.15 to 0.7
	2 position double	-100 kPa to 0.7
	3 position	-100 kPa to 0.7
Pilot pressure range (MPa) ^{Note 1)}	2 position single	Operating pressure to 0.7
	2 position double	0.1 to 0.7
	3 position	0.2 to 0.7
Ambient and fluid temperature (°C)		-10 to 50 (No freezing. Refer to back page 3.)
Lubrication		Not required
Mounting orientation		Unrestricted
Impact/Vibration resistance (m/s ²) ^{Note 2)}		300/50



Note 1) In case of single type, be certain that pressure within operating pressure range be supplied to supply port, because return pressure is introduced from supply port {1(P)} for activation.

Note 2) Impact resistance: No malfunction resulted from the impact test using a drop impact tester. The test was performed on the axis and right angle directions of the main valve, when pilot signal is ON and OFF. (Value in the initial state)
Vibration resistance: No malfunction occurred in one sweep test between 45 and 2000 Hz. Test was performed to axis and right angle directions of the main valve

Pilot Pressure Range (Single pilot)

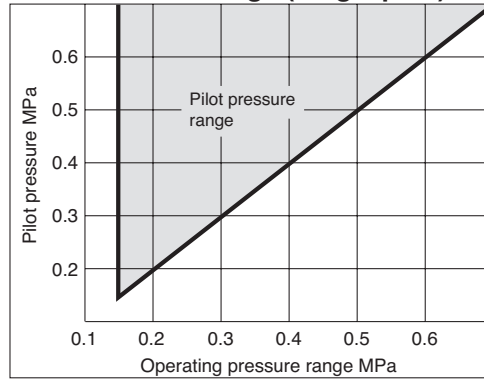

With Bracket

Air operated valve	SYJA3□20-M3-F
--------------------	---------------

The mounting bracket for the 2 position double solenoid and 3 position is supplied unattached.

Flow Characteristics/Weight

* Refer to the memo for changed contents.

Valve model	Type of actuation	Port size	Pilot port size	Weight (g) ^{Note 3)}	Effective area mm ²	Flow characteristics ^{Note 2)}								
						1 → 4/2 (P → A/B)				4/2 → 5/3 (A/B → EA/EB)				
						C [dm ³ /(s·bar)]	b	Cv	Q[l/min(ANR)]*	C [dm ³ /(s·bar)]	b	Cv	Q[l/min(ANR)]*	
5 port Base mounted (with sub-plate)	2 position	Single	M5	M3	48 (22)	-	0.46	0.36	0.12	122	0.46	0.35	0.12	121
	3 position	Exhaust center	54 (28)	0.36	0.39	0.10	97	0.59 [0.40]	0.43 [0.33]	0.16 [0.11]	164			
												Pressure center	0.58 [0.32]	0.42 [0.33]
Body ported	2 position	Single	M3	M3	22	0.9	0.46	0.36	0.12	122	0.46	0.35	0.12	121
	3 position	Closed center	28	0.36	0.39	0.10	97	0.59 [0.40]	0.43 [0.33]	0.16 [0.11]	164			
												Exhaust center	0.58 [0.32]	0.42 [0.33]
4 Port Base Mounted (For manifold) ^{Note 1)}	2 position	Single	-	M3	22	0.9	0.46	0.36	0.12	122	0.46	0.35	0.12	121
	3 position	Closed center	28	0.36	0.39	0.10	97	0.59 [0.40]	0.43 [0.33]	0.16 [0.11]	164			
												Exhaust center	0.58 [0.32]	0.42 [0.33]
Pressure center	0.58 [0.32]	0.42 [0.33]	0.16 [0.080]	160 [83]	0.46	0.32	0.11	[104] 118						



Note 1) Value when used on a manifold. Refer to page 69 for details.
Note 2) []: denotes normal position.

Note 3) (): Without sub-plate.

Note 4) 5 port, base mounted without sub-plate: SYJA3□40

* These values have been calculated according to ISO6358 and represent the flow rate measured in standard conditions at an upstream of 0.6MPa (relative pressure) and a differential pressure of 0.1MPa.

Series SYJA3000

Dimensions/Body Ported

2 position single: SYJA3120-M3(-F)

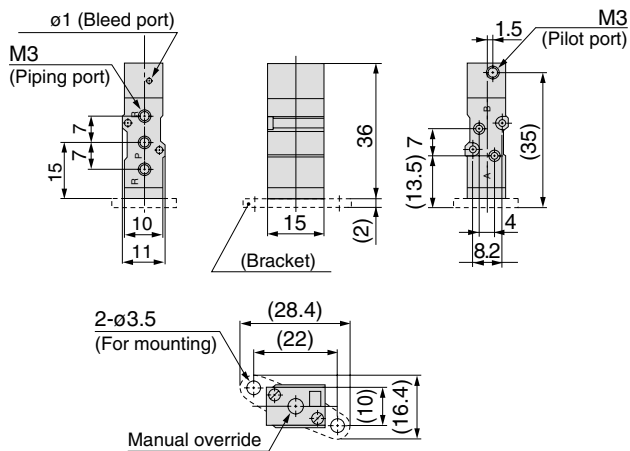

Dimensions/Base Mounted

2 position single: SYJA3140-M5

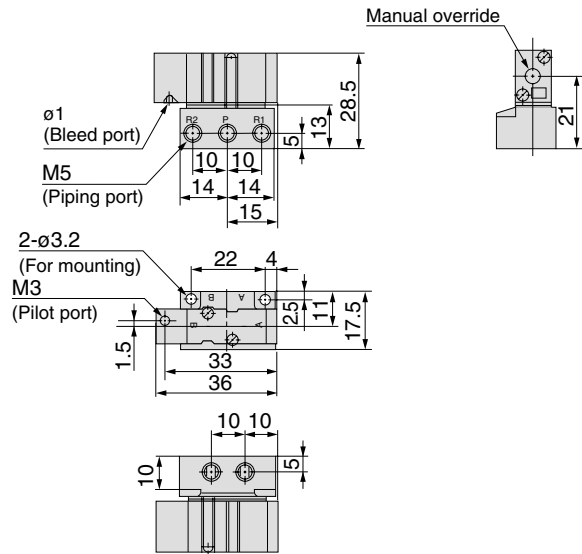

2 position double: SYJA3220-M3(-F)

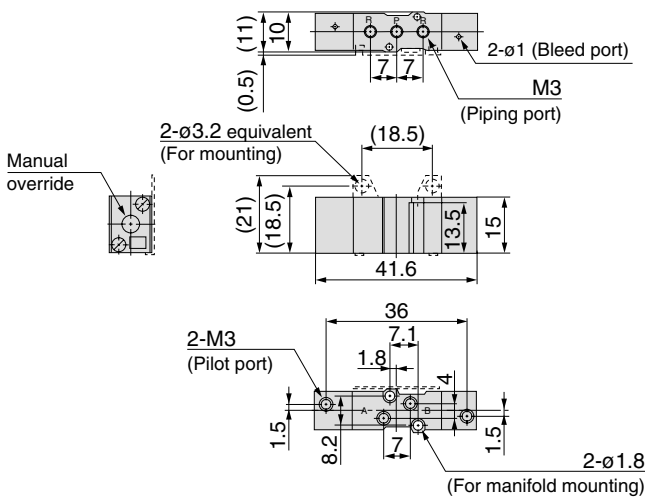

2 position double: SYJA3240-M5

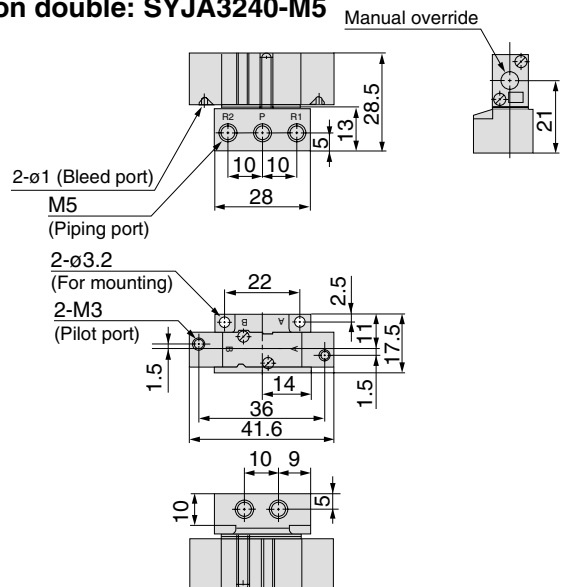

3 position closed center/exhaust center/pressure center SYJA3₃⁴20-M3(-F)

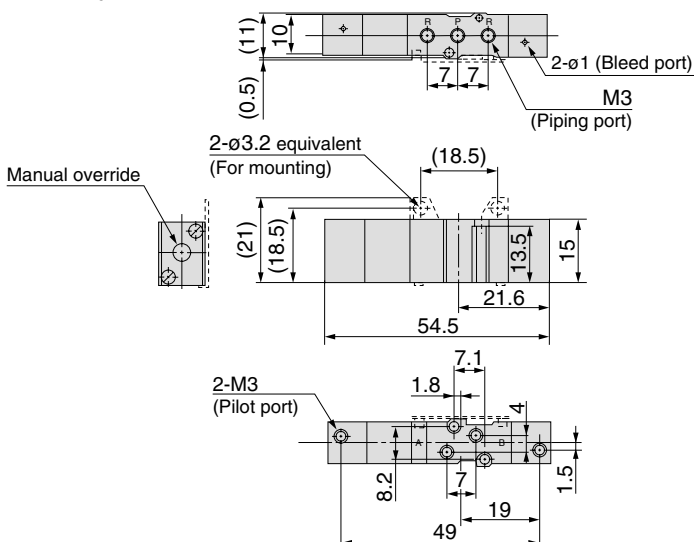

3 position closed center/exhaust center/pressure center SYJA3₃⁴40-M5

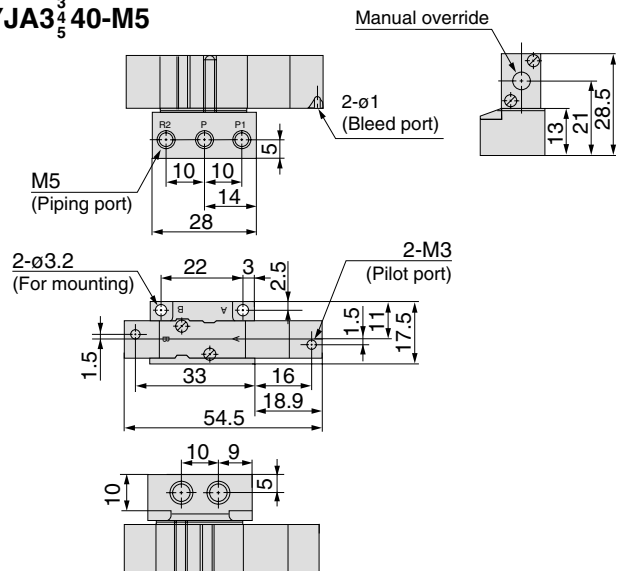

4/5 Port Air Operated Valve Series SYJA5000

How to Order

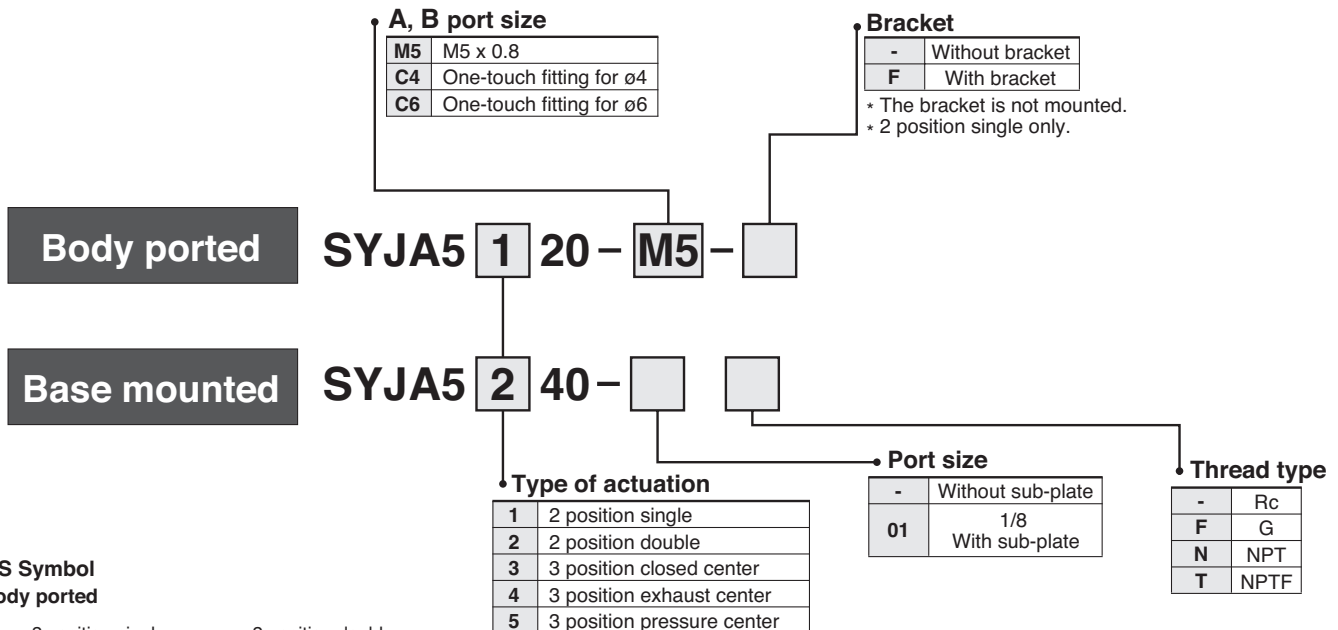

JIS Symbol Body ported

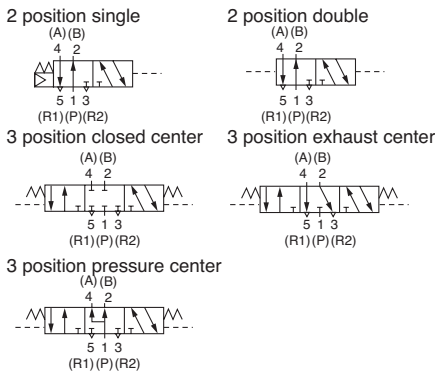

Base mounted

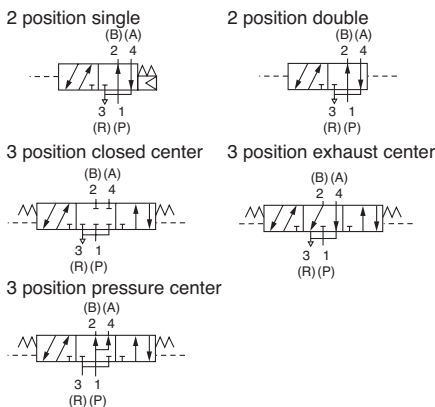

How to Order Manifold Base

Same manifolds as series SYJ5000 are prepared.

SS5YJA5 - Fill the same as **SS5YJ5**.

Instruct by specifying the valves and blanking plate assembly to be mounted on the manifold along with the manifold base model no.

(Ex.)
SS5YJA5-42-03-01 1 set
 * SYJA5140 1 set
 * SYJA5240 1 set
 * SYJ5000-21-1A 1 set

↳ The asterisk denotes the symbol for assembly. Prefix it to the part nos. of the solenoid valve, etc.

Caution

Refer to back page 1 through to 5 for Safety Instructions and Common Precautions.

Series SYJA5000

Specifications

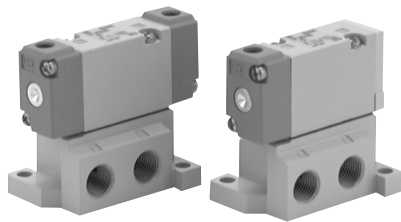

Base mounted

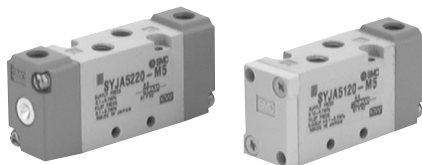

Body ported

Fluid	Air	
Operating pressure range (MPa)	2 position single	0.15 to 0.7
	2 position double	-100 kPa to 0.7
	3 position	-100 kPa to 0.7
Pilot pressure range (MPa) <small>Note 1)</small>	2 position single	(0.4 x P+0.1) to 0.7 P: Operating pressure
	2 position double	0.1 to 0.7
	3 position	0.15 to 0.7
Ambient and fluid temperature (°C)	-10 to 60 (No freezing)	
Lubrication	Not required	
Mounting orientation	Unrestricted	
Impact/Vibration resistance (m/s²) <small>Note 2)</small>	300/50	



Note 1) In case of single type, be certain that pressure within operating pressure range be supplied to supply port, because return pressure is introduced from supply port {1(P)} for activation.

Note 2) Impact resistance: No malfunction resulted from the impact test using a drop impact tester. The test was performed on the axis and right angle directions of the main valve, when pilot signal is ON and OFF. (Value in the initial state)

Vibration resistance: No malfunction occurred in one sweep test between 45 and 2000 Hz. Test was performed to axis and right angle directions of the main valve when pilot signal is ON and OFF. (Value in the initial state)

Pilot Pressure Range (Single pilot)

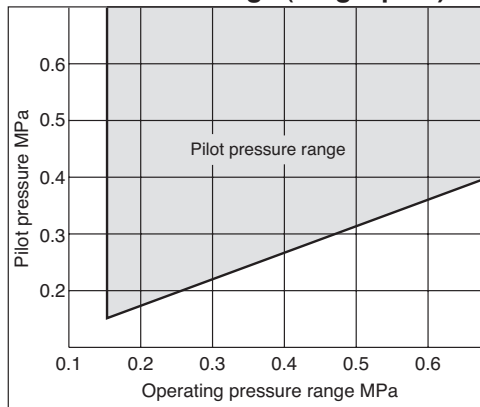

With Bracket

Air operated valve	SYJA5120-M5-F
---------------------------	---------------

The mounting bracket is supplied unattached.

Bracket assembly	SYJA5000-13-13A
-------------------------	-----------------

Mounting screws included.

Flow Characteristics/Weight

Valve model	Type of actuation	Port size	Flow characteristics <small>Note 1)</small>								Pilot port size	Weight (g) <small>Note 2)</small>			
			1→4/2 (P→A/B)				4/2→5/3 (A/B→EA/EB)								
			C [dm ³ /s-bar]	b	Cv	Q _l [min(ANR)]*	C [dm ³ /s-bar]	b	Cv	Q _l [min(ANR)]*					
Body ported	SYJA5□20-M5	2 position	Single	M5 x 0.8	0.47	0.41	0.13	129	0.47	0.41	0.13	129	M5 x 0.8	34	
			Double		0.49	0.44	0.13	137	0.44	0.40	0.12	120		38	
		3 position	Closed center		0.46	0.37	0.12	123	0.47	0.43	0.13	131		48	
			Exhaust center		0.49	0.51	0.14	145	0.45	0.42	0.12	124			
	SYJA5□20-C4	2 position	Single	A, B port: C4 (One-touch fitting for ø4) P, R port: M5	0.69	0.39	0.18	186	0.44	0.39	0.12	119		M5 x 0.8	41
			Double		0.69	0.40	0.19	188	0.43	0.40	0.12	117			45
		3 position	Closed center		0.56	0.40	0.15	152	0.41	0.37	0.10	109	55		
			Exhaust center		0.57	0.40	0.15	155	0.41	0.37	0.10	109			
	SYJA5□20-C6	2 position	Single	A, B port: C6 (One-touch fitting for ø6) P, R port: M5	0.70	0.36	0.19	185	0.47	0.40	0.12	128	M5 x 0.8		41
			Double		0.72	0.37	0.19	192	0.44	0.34	0.12	115			45
		3 position	Closed center		0.67	0.54	0.19	204	0.41	0.38	0.11	110		55	
			Exhaust center		0.82	0.41	0.23	225	0.41	0.36	0.11	108			
Base mounted (with sub-plate)	SYJA5□40-01	2 position	Single	1/8	0.79	0.21	0.19	190	0.83	0.32	0.21	214		M5 x 0.8	68 (34)
			Double		0.80	0.28	0.18	201	0.86	0.34	0.20	224			72 (38)
		3 position	Closed center		0.71	0.26	0.18	176	1.1	0.24	0.26	270	82(48)		
			Exhaust center		0.99	0.29	0.24	250	0.72	0.38	0.18	193			
		2 position	Single		0.79	0.21	0.19	190	0.83	0.32	0.21	214	M5 x 0.8		68 (34)
			Double		0.80	0.28	0.18	201	0.86	0.34	0.20	224			72 (38)
		3 position	Closed center		0.71	0.26	0.18	176	1.1	0.24	0.26	270		82(48)	
			Exhaust center		0.99	0.29	0.24	250	0.72	0.38	0.18	193			

Note 1) []: denotes normal position.

Note 2) (): Without sub-plate.

Note 3) Model No. for 5 port base mounted style without sub-plate is SYJA5□40.

* These values have been calculated according to ISO6358 and represent the flow rate measured in standard conditions at an upstream of 0.6MPa (relative pressure) and a differential pressure of 0.1MPa.

4/5 Port Air Operated Valve Series SYJA7000

How to Order

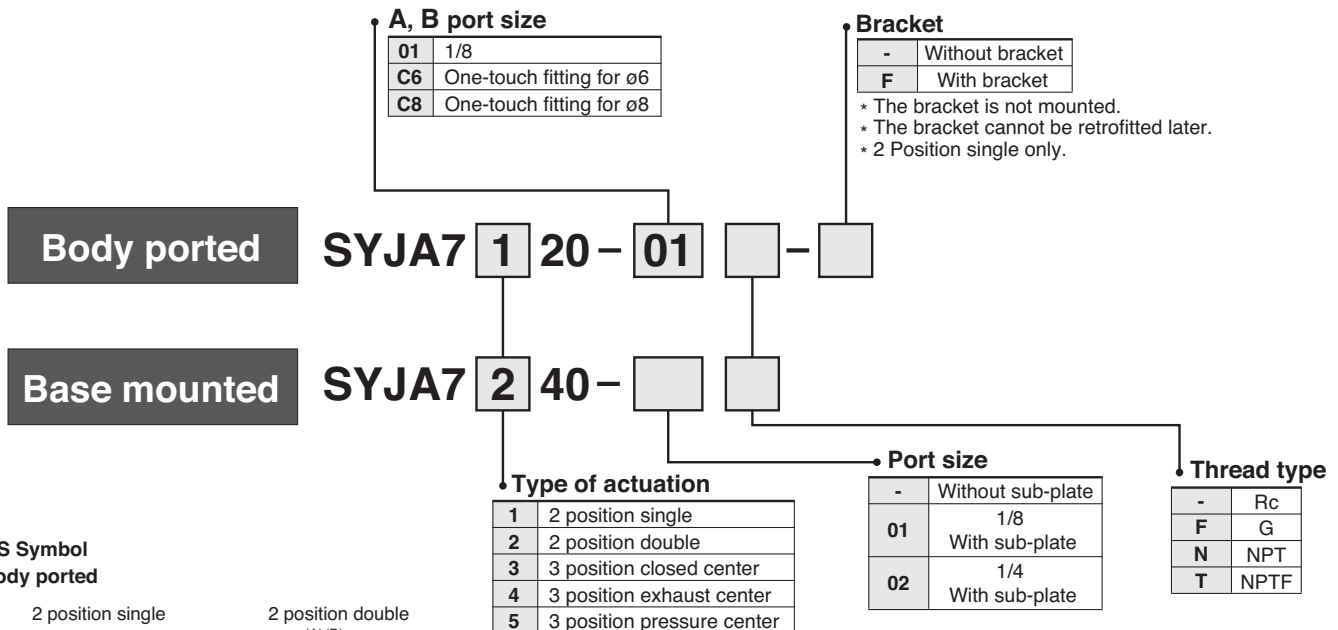

JIS Symbol Body ported

2 position single

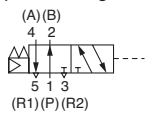

2 position double

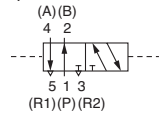

3 position closed center

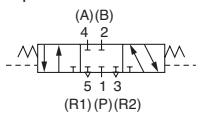

3 position exhaust center

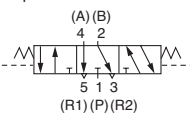

3 position pressure center

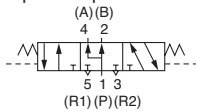

Base mounted

2 position single

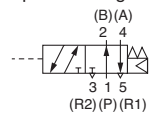

2 position double

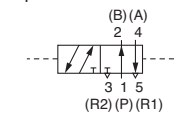

3 position closed center

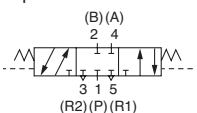

3 position exhaust center

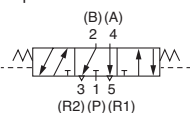

3 position pressure center

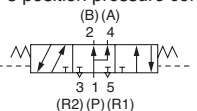

Caution

Refer to back page 1 through to 5 for Safety Instructions and Common Precautions.

How to Order Manifold Base

Same manifolds as series SYJ7000 are prepared.

SS5YJA7 - Fill the same as SS5YJ7.

Instruct by specifying the valves and blanking plate assembly to be mounted on the manifold along with the manifold base model no.

(Ex.)

SS5YJA7-41-03-01 1 pc.
* SYJA7140 1 pc.
* SYJA7240 1 pc.
* SYJ7000-21-1A 1 pc.

The asterisk denotes the symbol for assembly. Prefix it to the part nos. of the solenoid valve, etc.

Specifications

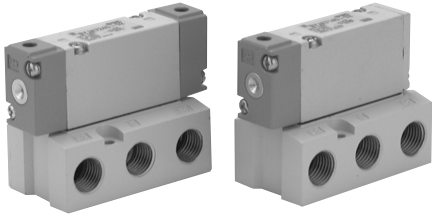

Base mounted

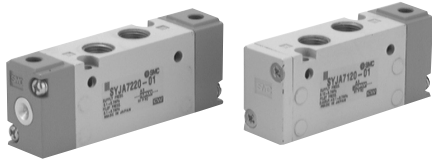

Body ported

Fluid		Air
Operating pressure range (MPa)	2 position single	0.15 to 0.7
	2 position double	-100 kPa to 0.7
	3 position	-100 kPa to 0.7
Pilot pressure range (MPa)	^{Note 1)} 2 position single	(0.4 x P+0.1) to 0.7 P: Operating pressure
	2 position double	0.1 to 0.7
	3 position	0.15 to 0.7
Ambient and fluid temperature (°C)		-10 to 60 (No freezing)
Lubrication		Not required
Mounting orientation		Unrestricted
Impact/Vibration resistance (m/s²) ^{Note 2)}		300/50

 Note 1) In case of single type, be certain that pressure within operating pressure range be supplied to supply port, because return pressure is introduced from supply port {1(P)} for activation.

Note 2) Impact resistance: No malfunction resulted from the impact test using a drop impact tester. The test was performed on the axis and right angle directions of the main valve, when pilot signal is ON and OFF. (Value in the initial state)

Vibration resistance: No malfunction occurred in one sweep test between 45 and 2000 Hz. Test was performed to axis and right angle directions of the main valve when pilot signal is ON and OFF. (Value in the initial state)

Pilot Pressure Range (Single pilot)

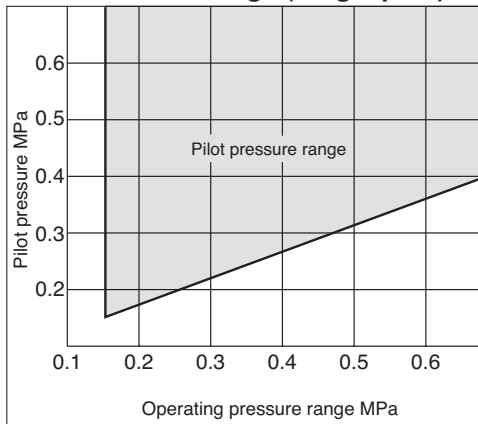

With Bracket

Air operated valve	SYJA7120-01-F
---------------------------	---------------

As a bracket is designed for a body, be sure that a bracket is attached when ordering and operating.

Series SYJA7000

Flow Characteristics/Weight

Valve model		Type of actuation		Port size		Flow characteristics ^{Note 2)}								Pilot port size	Weight ^{Note 3)} (g)	
						1→4/2 (P→A/B)				4/2→5/3 (A/B→EA/EB)						
						C [dm ³ /(s·bar)]	b	Cv	Q _l [min(ANR)]*	C [dm ³ /(s·bar)]	b	Cv	Q _l [min(ANR)]*			
Body ported	SYJA7□20-01	2 position	Single	1/8	2.2	0.36	0.58	582	2.4	0.34	0.63	626	M5 x 0.8	71		
			Double									72				
		3 position	Closed center		1.8	0.37	0.45	479	2.0	0.35	0.49	525		82		
			Exhaust center		1.2	0.50	0.34	353	3.0	0.35	0.73	788				
			Pressure center			3.0	0.37	0.78	799	1.8	0.37	0.45			479	
						[0.83]	[0.50]	[0.25]	[244]						[389]	
	SYJA7□20-C6	2 position	Single	A, B port: C6 (One-touch fitting for ø6) P, R port: 1/8	1.6	0.33	0.4	415	2.2	0.32	0.53	567			82	
			Double									83				
		3 position	Closed center		1.4	0.27	0.35	349	1.9	0.33	0.49	493		93		
			Exhaust center		1.1	0.37	0.27	293	2.5	0.32	0.61	644				
			Pressure center			1.8	0.36	0.45	476	1.6	0.30	0.39			407	
						[0.78]	[0.40]	[0.22]	[212]						[395]	
SYJA7□20-C8	2 position	Single	A, B port: C8 (One-touch fitting for ø8) P, R port: 1/8	2.0	0.39	0.52	540	2.3	0.34	0.61	600	82				
		Double									83					
	3 position	Closed center		1.7	0.35	0.42	447	2.0	0.29	0.49	505	93				
		Exhaust center		1.2	0.38	0.33	322	2.6	0.35	0.67	683					
		Pressure center			1.9	0.57	0.59	594	1.7	0.39	0.42		459			
					[0.86]	[0.46]	[0.25]	[245]					[379]			
Base mounted (with sub-plate)	SYJA7□40-01	2 position	Single	1/8 ^{Note 1)}	2.3	0.45	0.57	649	2.8	0.37	0.71		746	M5 x 0.8	151 (71)	
			Double										152 (72)			
		3 position	Closed center		1.9	0.36	0.48	503	2.1	0.46	0.57	598	162 (82)			
			Exhaust center		1.2	0.48	0.35	347	3.4	0.36	0.86	899				
			Pressure center			3.3	0.43	0.78	918	2.1	0.45	0.56			593	
						[0.85]	[0.54]	[0.25]	[259]						[406]	
	SYJA7□40-02	2 position	Single	1/4 ^{Note 1)}	2.3	0.41	0.61	630	2.9	0.35	0.74	762			M5 x 0.8	151 (71)
			Double									152 (72)				
		3 position	Closed center		1.9	0.46	0.50	541	2.2	0.44	0.60	616	162 (82)			
			Exhaust center		1.3	0.45	0.35	367	3.7	0.27	0.87	923				
			Pressure center			3.6	0.23	0.84	877	2.1	0.47	0.58				602
						[0.83]	[0.55]	[0.25]	[255]							[434]



Note1) P, A, B port: Rc1/8 is R1, R2 port: Rc (PT) 1/4

Note2) []: for normal position

Note3) (): without sub-plate

Note4) Model No. for base mounted style without sub-plate is SYJA□40.

* These values have been calculated according to ISO6358 and represent the flow rate measured in standard conditions at an upstream of 0.6MPa (relative pressure) and a differential pressure of 0.1MPa.

Dimensions/Body Ported

2 position single: SYJA7120-01□(-F)

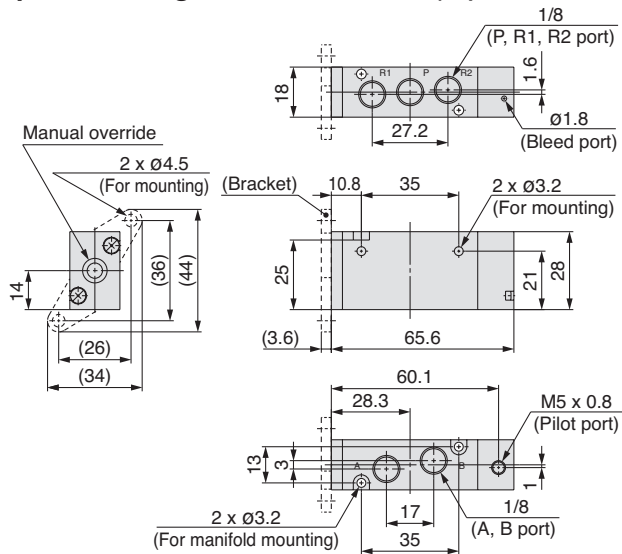

Dimensions/Base Mounted

2 position single: SYJA7140-01□₀₂

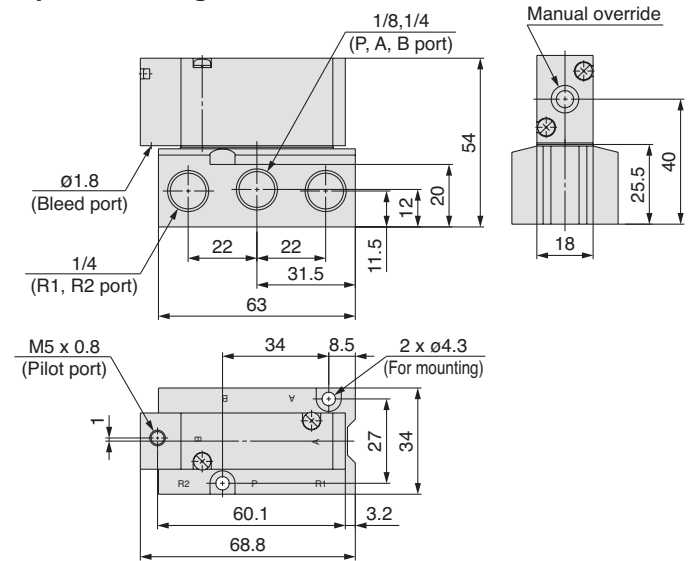

2 position double: SYJA7220-01□

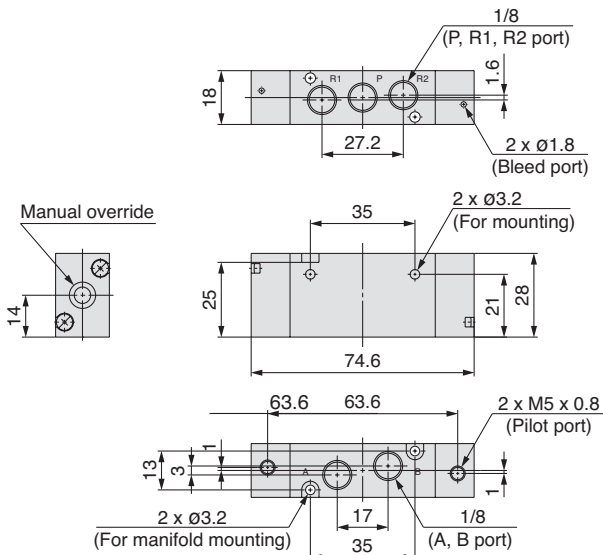

2 position double: SYJA7240-01□₀₂

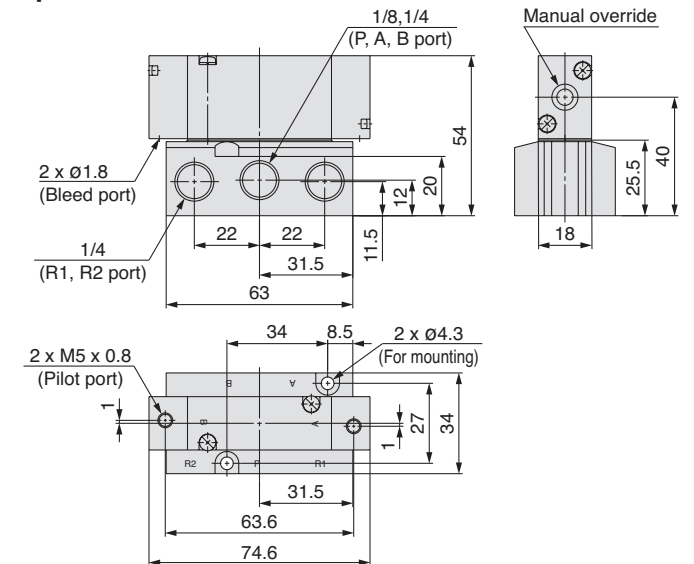

3 position closed center/exhaust center/pressure center SYJA7³/₄20-01□

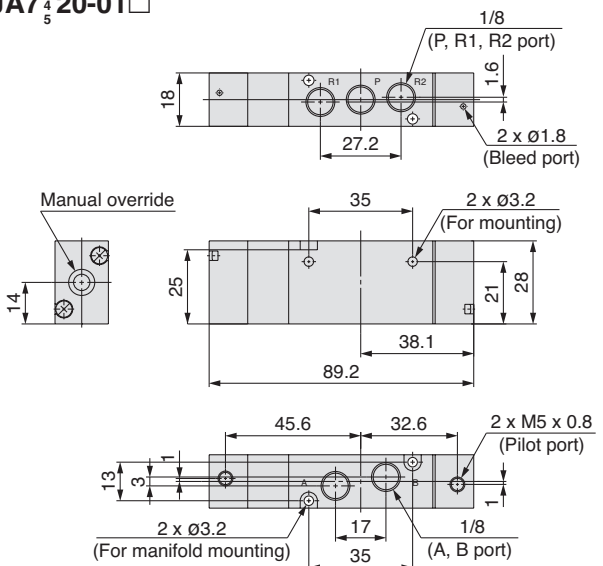

3 position closed center/exhaust center/pressure center SYJA7³/₄40-01□₀₂

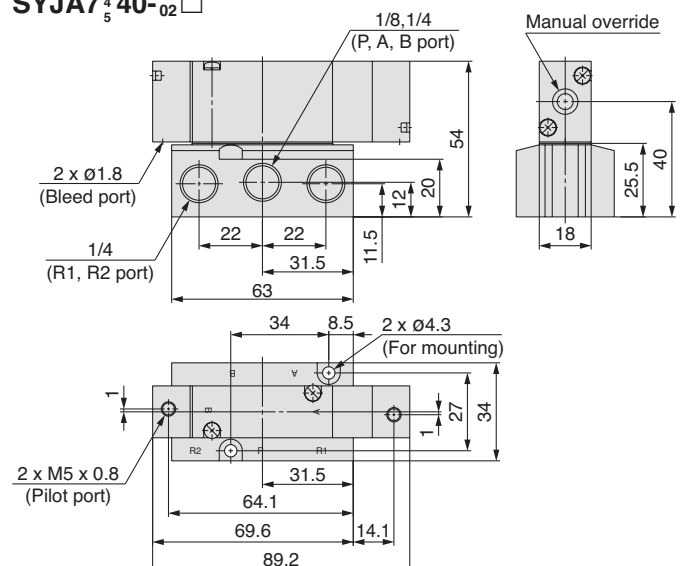

Series SYJ5000/7000

Made to Order



(For detailed specifications, delivery and pricing, please contact SMC.)

Body Ported External Pilot

Applicable solenoid valve series SYJ5□20R, SYJ7□20R

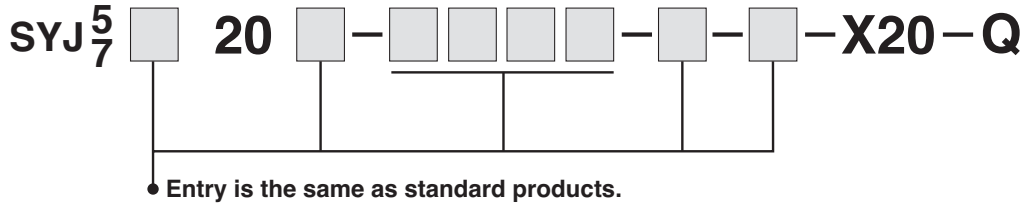

Operating Pressure Range MPa

Operating pressure range	-100 kPa to 0.7
Pilot pressure range	0.15 to 0.7

External Pilot Port

Series	Port size
SYJ5000, SYJ7000	M5

Dimensions

SYJ5000: 8 mm } longer in total length.
 SYJ7000: 8 mm }

JIS Symbol

Body ported

2 position single

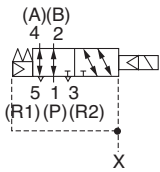

2 position double

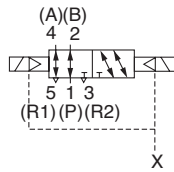

3 position closed center

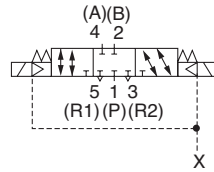

3 position exhaust center

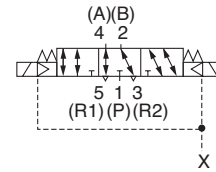

3 position pressure center

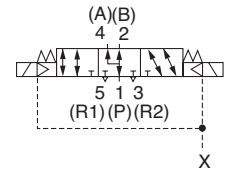

Series SYJ5000/7000

Made to Order



DIN Connector Conforming to EN-175301-803C (former DIN 43650C)

DIN connector type that conforms to the 8 mm pitch standards between DIN terminals.

How to Order Valve

Type of actuation

1	2 position single solenoid
2	2 position double solenoid
3	3 position closed center
4	3 position exhaust center
5	3 position pressure center

Light/surge voltage suppressor

-	Without light/surge voltage suppressor
S	With surge voltage suppressor
Z	With light/surge voltage suppressor

* YOZ is not available.
* For AC voltage valves there is no "S" option. It is already built-in to the rectifier circuit.

Rated voltage

DC	AC (50/60 Hz)
5	24 VDC
6	12 VDC
1	100 VAC
2	200 VAC
3	110 VAC [115 VAC]
4	220 VAC [230 VAC]

Bracket

-	Without bracket
F	With bracket

Note) Do not remove the factory installed bracket from models with the bracket option. Removal of the bracket will cause the valve to leak.

A, B port size

M5	M5
01	1/8 (SYJ7000 only)
C4	One-touch fitting for ø4
C6	One-touch fitting for ø6
N3	One-touch fitting for ø5/32"
N7	One-touch fitting for ø1/4"

Body option

0	Pilot valve individual exhaust for the pilot valve
3	Common exhaust type for main and pilot valve

Electrical entry

Y: With connector
YO: Without connector

Thread type

-	Rc
F	G
N	NPT
T	NPTF

Port size

-	Without sub-plate	
01	1/8	SYJ5000
02	1/4	SYJ7000

Manual override

-	Non-locking push type
D	Push-turn locking slotted type
E	Push-turn locking lever type

Series

5	SYJ5000
7	SYJ7000

Body ported SYJ 5 1 2 0 5 Y [] [] M5 [] [] Q

Base mounted SYJ 5 2 4 0 5 Y [] [] [] [] Q

How to Order Pilot Valve Assembly

V115 — 5 Y []

Rated voltage

DC	AC (50/60 Hz)
5	24 VDC
6	12 VDC
1	100 VAC
2	200 VAC
3	110 VAC [115 VAC]
4	220 VAC [230 VAC]

Light/surge voltage suppressor

-	Without light/surge voltage suppressor
S	With surge voltage suppressor
Z	With light/surge voltage suppressor

* YOZ is not available.
* For AC voltage valves there is no "S" option. It is already built-in to the rectifier circuit.

Electrical entry

Y	DIN	With connector
YO	terminal	Without connector

DIN Connector Part No.

Without light	SY100-82-1	
With light		
Rated voltage	Voltage symbol	No.
24 VDC	24 VN	SY100-82-3-05
12 VDC	12 VN	SY100-82-3-06
100 VAC	100 VN	SY100-82-3-01
200 VAC	200 VN	SY100-82-3-02
110 VAC (115 VAC)	110 VN	SY100-82-3-03
220 VAC (230 VAC)	220 VN	SY100-82-3-04

⚠ Caution

- Use caution in wiring because it won't meet the IP65 (enclosure) standard if you use the other cord than prescribed heavy-duty cord of size (ø3.5 to ø7.5). Also be sure to tighten the ground nut and holding screw with the prescribed torque range. Tighten the ground nut and set screw within the specified range of torque. For how to use DIN terminal (wiring procedures, procedures for changing electrical entries, precautions, applicable cable, circuit diagram), refer to back page 8.
- D type DIN connector with 9.4 mm pitch between terminals is not interchangeable.
- DIN connector except D type has the "N" indication in the end of voltage symbol. In case of DIN connector without light, "N" is not indicated. Please refer to the name plate to distinguish.
- Dimensions are completely the same as D type connector.
- When exchanging the pilot valve assembly only, "V115-□□" is interchangeable with "V115-□Y". Do not replace V114 (G, H, L, M, W) to V115-□□/□Y (DIN terminal), and vice versa.

Series SYJ3000/5000/7000

Made to Order

M8 Connector Conforming to IEC60947-5-2

M8 Connector type conforming to IEC60947-5-2 standard.



How to Order Valve

Type of actuation

1	2 position single solenoid
2	2 position double solenoid
3	3 position closed centre
4	3 position exhaust centre
5	3 position pressure centre

Light/surge voltage suppressor

-	Without light/surge voltage suppressor
S	With surge voltage suppressor
Z	With light/surge voltage suppressor
R	With surge voltage suppressor (Non-polar type)
U	With light/surge voltage suppressor (Non-polar type)

Thread type

-	Rc
F	G
N	NPT
T	NPTF

Bracket

-	Without bracket
F	With bracket

Note) Do not remove the factory installed bracket from models with the bracket option. Removal of the bracket will cause the valve to leak.

Rated voltage DC

5	24 VDC
6	12 VDC
V	6 VDC
S	5 VDC
R	3 VDC

A, B port size

M3	M3 (SYJ3000 only)
M5	M5
01	1/8 (SYJ7000 only)
C4	One-touch fitting for "4"
C6	One-touch fitting for "6"
N3	One-touch fitting for "5/32"
N7	One-touch fitting for "1/4"

Made to Order

-	-
X20	Body ported external pilot

* X20 is not available for the SYJ3000 series.

Body ported SYJ 3 1 2 0 5 WAO [] [] M3 [] [] [] Q

Base mounted (4 port) SYJ 3 2 3 0 5 WAO [] [] Q (For SYJ3000 manifold use only)

Base mounted (5 port) SYJ 3 2 4 0 5 WAO [] [] [] [] Q

Series

3	SYJ3000
5	SYJ5000
7	SYJ7000

Body option

0: Pilot valve individual exhaust for the pilot valve

3: Common exhaust type for main and pilot valve

Electrical entry

WAO: Without connector cable



WA1: With connector cable (Length 0,3 m)

WA2: With connector cable (Length 0,5 m)

WA3: With connector cable (Length 1 m)

WA4: With connector cable (Length 2 m)

WA7: With connector cable (Length 5 m)



Thread type

-	Rc
F	G
N	NPT
T	NPTF

Port size

-	Without sub-plate	
M5	SYJ3000	
01	1/8	SYJ5000
		SYJ7000
02	1/4	SYJ7000

Manual override

-	Non-locking push type
D	Push-turn locking slotted type
E	Push-turn locking lever type

How to Order Pilot Valve Assembly

V115 — 5 WAO [] []

Rated voltage DC

5	24 VDC
6	12 VDC
V	6 VAC
S	5 VAC
R	3 VAC

Light/surge voltage suppressor

-	Without light/surge voltage suppressor
S	With surge voltage suppressor
Z	With light/surge voltage suppressor
R	With surge voltage suppressor (Non-polar type)
U	With light/surge voltage suppressor (Non-polar type)

Electrical entry

WAO	Without connector cable
WA []	With connector cable

Note: [] is for cable length. Please refer to specific Product Precautions 5.





Series SYJ

Safety Instructions

These safety instructions are intended to prevent a hazardous situation and/or equipment damage. These instructions indicate the level of potential hazard by labels of "Caution", "Warning" or "Danger". To ensure safety, be sure to observe ISO 4414 ^{Note 1)}, JIS B 8370 ^{Note 2)} and other safety practices.

 **Caution** : Operator error could result in injury or equipment damage.

 **Warning** : Operator error could result in serious injury or loss of life.

 **Danger** : In extreme conditions, there is a possible result of serious injury or loss of life.

Note 1) ISO 4414: Pneumatic fluid power--General rules relating to systems.

Note 2) JIS B 8370: General Rules for Pneumatic Equipment

Warning

1. The compatibility of pneumatic equipment is the responsibility of the person who designs the pneumatic system or decides its specifications.

Since the products specified here are used in various operating conditions, their compatibility for the specific pneumatic system must be based on specifications or after analysis and/or tests to meet your specific requirements. The expected performance and safety assurance will be the responsibility of the person who has determined the compatibility of the system. This person should continuously review the suitability of all items specified, referring to the latest catalogue information with a view to giving due consideration to any possibility of equipment failure when configuring a system.

2. Only trained personnel should operate pneumatically operated machinery and equipment.

Compressed air can be dangerous if an operator is unfamiliar with it. Assembly, handling or repair of pneumatic systems should be performed by trained and experienced operators.

3. Do not service machinery/equipment or attempt to remove components until safety is confirmed.

1. Inspection and maintenance of machinery/equipment should only be performed once measures to prevent falling or runaway of the driver objects have been confirmed.
2. When equipment is to be removed, confirm the safety process as mentioned above. Cut the supply pressure for this equipment and exhaust all residual compressed air in the system.
3. Before machinery/equipment is restarted, take measures to prevent shooting-out of cylinder piston rod, etc.

4. Contact SMC if the product is to be used in any of the following conditions:

1. Conditions and environments beyond the given specifications, or if product is used outdoors.
2. Installation on equipment in conjunction with atomic energy, railway, air navigation, vehicles, medical equipment, food and beverages, recreation equipment, emergency stop circuits, clutch and brake circuits in press applications, or safety equipment.
3. An application which has the possibility of having negative effects on people, property, or animals, requiring special safety analysis.



4/5 Port Solenoid Valves/Common Precautions 1

Be sure to read before handling.

Design

⚠ Warning

1. Actuator drive

When an actuator, such as a cylinder, is to be driven using a valve, take appropriate measures to prevent potential danger caused by actuator operation.

2. Intermediate stopping

When a 3 position closed center valve is used to stop a cylinder at an intermediate position, accurate stopping of the piston in a predetermined position is not possible due to the compressibility of air. Furthermore, since valves and cylinders are not guaranteed for zero air leakage, it may not be possible to hold a stopped position for an extended length of time. Contact SMC if it is necessary to hold a stopped position for an extended time.

3. Effect of back pressure when using a manifold

Use caution when valves are used on a manifold, as actuator malfunction due to back-pressure may occur. In case of 3 position closed exhaust center valve or single acting cylinder, take appropriate measures to prevent the malfunction using with individual EXH interface assembly or individual exhaust manifold.

4. Holding of pressure (including vacuum)

Since valves are subject to air leakage, they cannot be used for applications such as holding pressure (including vacuum) in a pressure vessel.

5. Cannot be used as an emergency shut off valve, etc.

The valves presented in this catalogue are not designed for safety applications such as an emergency shut off valve. If the valves are used in this type of system, other reliable safety assurance measures should also be adopted.

6. Maintenance space

The installation should allow sufficient space for maintenance activities (removal of valve, etc.).

7. Release of residual pressure

Provide a residual pressure release function for maintenance purpose. Especially in case of 3 position closed center valve, ensure the release of residual pressure between valve and cylinder.

8. Vacuum applications

When a valve is used for vacuum switching, etc., take measures against the suction of external dust or other contaminants from vacuum pads and exhaust ports, etc. Moreover, an external pilot type valve should be used in this case. Contact SMC in case of an internal pilot type or air operated valve, etc.

9. About using the double solenoid type

When using the double solenoid type for the first time, actuators may travel in an unexpected direction depending on the switching position of a valve. Implement countermeasures not to occur any danger by the actuator's operation.

10. Ventilation

When a valve is used inside a sealed control panel, etc., provide ventilation to prevent a pressure increase caused by exhausted air inside the control panel or temperature rise caused by the heat generated by the valve.

Selection

⚠ Warning

1. Confirm the specification

The products presented in this catalogue are designed only for use in compressed air systems (including vacuum). Do not operate at pressures or temperatures, etc., beyond the range of specifications, as this can cause damage or malfunction. (Refer to specifications.)

Contact SMC when using a fluid other than compressed air (including vacuum).

2. Extended periods of continuous energisation

- Continuous energisation of the valve for extended periods of time may have an adverse effect on the solenoid valve performance and the peripheral equipment due to temperature rises caused by the heat generation of the coil. Consult with SMC if valves will be continuously energised for extended periods of time or the energised period per day will be longer than the de-energised period. It is also possible to shorten the energisation period by using valves of the N.O. (normally open) type.

- When solenoid valves are mounted in a control panel, employ measures to radiate excess heat, so that temperatures remain within the valve specification range. Use special caution when three or more stations sequentially aligned on the manifold are continuously energised since this will cause a drastic temperature rise.

(As for AC specifications, since the applicable products are ready to provide separately, contact SMC.)

⚠ Caution

1. Momentary energisation

If a double solenoid valve will be operated with momentary energisation, it should be energised for at least 0.1 second. However, depending on the secondary load conditions, it should be energised until the cylinder reaches the stroke end position, as there is a possibility of malfunction otherwise.

2. Leakage voltage

When using a resistor in parallel with the switching element or using a C-R element (surge voltage suppressor) for protection of the switching element, note that leakage voltage will increase due to leakage current flowing through the resistor or C-R element. Limit the amount of residual leakage voltage to the following value:

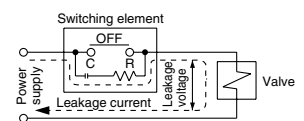

With DC coil : 3% or less of rated voltage

With AC coil : 8% or less of rated voltage



4/5 Port Solenoid Valves/Common Precautions 2

Be sure to read before handling.

Selection

⚠ Caution

3. Solenoid valve drive for AC with solid state output (SSR, TRIAC output, etc.)

1) Current leakage

When using a snubber circuit (C-R element) for surge protection of the output element, a very small electric current will still continue to flow in spite of the OFF state. This results in the valve not returning. In the cases when exceeding the tolerance as shown above, take measures to install a bleeder resistor.

2) Minimum load allowable amount (Min. load current)

When the consumption current of a valve is less than the output element's minimum load allowable volume or the margin is small, the output element may not be switched normally. Please confirm SMC.

4. Surge voltage suppressor

If a surge protection circuit contains non-ordinary diodes such as Varistor, a residual voltage that is in proportion to the protective elements and the rated voltage will remain. Therefore, give consideration to surge voltage protection of the controller. In the case of diodes, the residual voltage is approximately 1 V.

5. Use in low temperature environments

Unless otherwise indicated in the specifications for each valve, operation is possible to -10°C , but appropriate measures should be taken to avoid solidification or freezing of drainage and moisture, etc.

6. Operation for air blowing

When using a solenoid valve for air blow, use an external pilot type.

Take note that when internal pilots and external pilots are used on the same manifold, the pressure drop caused by the air blowing can have an effect on the internal pilot type valves.

Moreover, when compressed air within the pressure range of the established specifications is supplied to the external pilot port, and a double solenoid valve is used for air blowing, the solenoids should normally be energised when air is being blown.

7. Mounting orientation

Rubber seal: Refer to the specifications of each series.

Mounting

⚠ Warning

1. If air leakage increases or equipment does not operate properly, stop operation.

Check mounting conditions when air and power supplies are connected. Initial function and leakage tests should be performed after installation.

2. Instruction manual

Mount and operate the product after reading the manual carefully and understanding its contents.

Also keep the manual where it can be referred to as necessary.

3. Painting and coating

Warnings or specifications printed or pasted on the product should not be erased, removed or covered up. Consult with SMC if paint is to be applied to resinous parts, as this may have an adverse effect due to the paint solvent.

Port Direction

⚠ Caution

1. Preparation before piping

Before piping is connected, it should be thoroughly blown out with air (flushing) or washed to remove chips, cutting oil and other debris from inside the pipe.

2. Wrapping of sealant tape

When connecting pipes and fittings, etc., be sure that chips from the pipe thread and sealing materials do not get inside the valve. Furthermore, when pipe tape is used, leave 1.5 to 2 thread ridges exposed at the end of the threads.

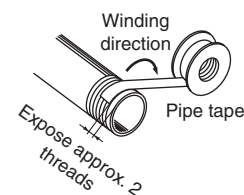

3. Closed center valves

When using closed center type valves, carefully check to ascertain that there is no air leakage from the piping between the valves and cylinders.

4. Screwing in fittings

When connecting fittings to valves, tighten as indicated below.

1) For M3 and M5 type

- (1) When using SMC fittings, follow the guidelines below. After tightening by hand, tighten an additional M3: 1/4, M5: 1/6 turn with a tightening tool. However, if miniature fittings are used, tighten an additional 1/4 turn with a tightening tool after tightening by hand. For fittings with gaskets in 2 locations, e.g., universal elbow or universal tee, tighten an additional 1/2 turn.

Note) If fittings are over-tightened, air leakage may result due to breaking of fitting threads or deformation of the gaskets. However, if fittings are not tightened sufficiently, loosening of the threads and air leakage and may occur.

- (2) When fittings other than SMC fittings are used, follow the instructions of the respective fitting manufacturer.

2) For Rc (PT)

When installing fitting, etc., follow the given torque levels below.

Tightening Torque for Piping

Connection threads	Applicable tightening torque N·m
1/8	7 to 9
1/4	12 to 14
3/8	22 to 24
1/2	28 to 30
3/4	28 to 30
1	36 to 38
1 1/4	40 to 42
1 1/2	48 to 50
2	48 to 50

5. Connection of piping to products

When connecting piping to a product, refer to its instruction manual to avoid mistakes regarding the supply port, etc.



4/5 Port Solenoid Valves/Common Precautions 3

Be sure to read before handling.

Wiring

Caution

1. Polarity

When connecting power to a DC specification solenoid valve equipped with (indicator light) surge voltage suppressor, confirm whether or not there is polarity.

If there is polarity, take note of the following points.

Without built-in diode to protect polarity (including any power saving circuit):

If a mistake is made regarding polarity, the diode in the valve, the control device switching element or power supply equipment, etc., may burn out.

With diode to protect polarity:

If a mistake is made regarding polarity, it will not be possible to switch the valve.

2. Applied voltage

When electric power is connected to a solenoid valve, be careful to apply the proper voltage. Improper voltage may cause malfunction or coil damage.

3. Confirm the connections.

After completing the wiring, confirm that the connections are correct.

Lubrication

Caution

1. Lubrication

[Rubber seal]

1) The valve has been lubricated for life at the factory, and does not require any further lubrication.

2) In the event that it is lubricated, use class 1 turbine oil (without additives), ISO VG32.

However, once lubrication is applied it must be continued, as loss of the original lubricant may lead to malfunction.

Contact SMC regarding class 2 turbine oil (with additives), ISO VG32.

Air Supply

Warning

1. Use clean air.

Do not use compressed air which contains chemicals, synthetic oils containing organic solvents, salts or corrosive gases, etc., as this can cause damage or malfunction.

Air Supply

Caution

1. Install air filters.

Install air filters close to valves at their upstream side. A filtration degree of 5 μm or less should be selected.

2. Install an air dryer, after cooler or Drain Catch (water separator), etc.

Air that includes excessive drainage may cause malfunction of valves and other pneumatic equipment. To prevent this, install an air dryer, after-cooler or Drain Catch (water separator), etc.

3. If excessive carbon dust is generated, eliminate it by installing mist separators at the upstream side of valves.

If excessive carbon dust is generated by the compressor, it may adhere to the inside of valves and cause malfunction.

Refer to "SMC Best Pneumatics" catalogue for compressed air quality.

Operating Environment

Warning

1. Do not use valves in atmospheres of corrosive gases, chemicals, salt water, water or steam or where there is direct contact with any of these.

2. Products with IP65 enclosures (based on IEC60529) are protected against dust and water, however, these products cannot be used in water.

Take measures to prevent water and dust from coming from the exhaust port.

3. Products compliant to IP65 satisfy the specifications by mounting each product properly. Be sure to read the Specific Product Precautions for each product.

4. Do not use in an explosive atmosphere.

5. Do not use in locations subject to vibration or impact. Confirm the specifications in the main section of the catalogue.

6. A protective cover, etc., should be used to shield valves from direct sunlight.

7. Shield valves from radiated heat generated by nearby heat sources.

8. Employ suitable protective measures in locations where there is contact with water droplets, oil or welding spatter, etc.

9. When solenoid valves are mounted in a control panel or are energised for extended periods of time, employ measures to radiate excess heat, so that temperatures remain within the valve specification range.



4/5 Port Solenoid Valves/Common Precautions 4

Be sure to read before handling.

Maintenance

Warning

1. Perform maintenance procedures as shown in the instruction manual.

If handled improperly, malfunction or damage of machinery or equipment may occur.

2. Equipment removal and supply/exhaust of compressed air

When equipment is removed, first confirm that measures are in place to prevent dropping of work pieces and run-away of equipment, etc. Then cut the supply pressure and power, and exhaust all compressed air from the system using its residual pressure release function.

In the case of 3 position closed center style, exhaust the residual pressure between valve and cylinder.

When the equipment is to be started again after remounting or replacement, first confirm that measures are in place to prevent lurching of actuators, etc., and then confirm that the equipment is operating normally.

3. Low frequency operation

Valves should be switched at least once every 30 days to prevent malfunction. (Use caution regarding the air supply.)

4. Manual override operation

When the manual override is operated, connected equipment will be actuated. Confirm safety before operating.

Caution

1. Drain flushing

Remove drainage from air filters regularly.



Series SYJ3000/5000/7000 Specific Product Precautions 1

Be sure to read this before handling the products. For safety instructions and 3/4/5-port solenoid valve precautions, refer to the “Handling Precautions for SMC Products” and the “Operation Manual” on the SMC website: <https://www.smc.eu>

Manual Override Operation

Warning

When the manual override is operated, connected equipment will be actuated. Confirm safety before operating.

Non-locking push type [Standard]

Press in the direction of the arrow

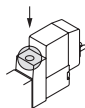

Push-turn locking slotted type [Type D]

While pressing, turn in the direction of the arrow. If it is not turned, it can be operated the same way as the non-locking type.

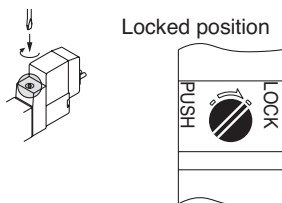

Caution

When operating the locking type D with a screw driver, turn it gently using a watchmakers screw driver. [Torque: Less than 0.1 N·m]

Push-turn locking lever type [Type E]

While pressing, turn in the direction of the arrow. If it is not turned, it can be operated the same way as the non-locking type.

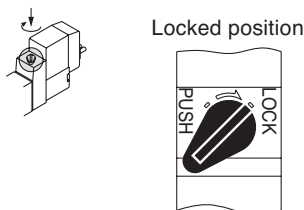

Caution

When locking the manual override on the push-turn locking types (D, E), be sure to push it down before turning. Turning without first pushing it down can cause damage to the manual override and trouble such as air leakage, etc.

Output Port

Caution

For the SYJ series, due to the main valve construction, as air is output to the output port on the side opposite of where the energized pilot valve and manual override are located, be careful when using double solenoid or 3-position valves. Check the symbol for details.

Solenoid Valve for 200 V, 220 VAC Specifications

Warning

Solenoid valves with DIN terminal connector AC specifications have a built-in rectifier circuit in the pilot section to operate the DC coil.

With 200 V, 220 VAC specification pilot valves, this built-in rectifier generates heat when energised. The surface may become hot depending on the energised condition; therefore, do not touch the solenoid valves.

Common Exhaust Type for Main and Pilot Valve

Caution

Pilot air is exhausted through the main valve body rather than directly to atmosphere.

- Suitable for applications where exhausting the pilot valve to atmosphere would be detrimental to the surrounding working environment.
- For use in extremely dirty environments where there is the possibility that dust could enter the pilot exhaust and damage the valve.

Series SYJ3000/5000/7000 Mixed Installation of 3 Port and 5 Port Valves on Same Manifold.

Caution

Series SYJ3000/5000/7000 and Series SYJ300/500/700 can be mounted on the same manifold. How to mount on the same manifold is shown on the following pages.

SYJ3000, SYJ300	P. 14
SYJ5000, SYJ500	P. 38
SYJ7000, SYJ700	P. 61

If 4 or 5 port valve is used as a 3 port valve Series SYJ3000, 5000, 7000 may be used as a N.C. or N.O. 3 port valve by plugging one of the A, B ports. Be sure not to plug the exhaust ports (R). Can be used when a double solenoid, 3 port valve is required.

Plug position		B port	A port
Type of actuation		N.C.	N.O.
Number of solenoids	Single		
	Double		

(JIS symbols above: Series SYJ5000)



Series SYJ3000/5000/7000

Specific Product Precautions 2

Be sure to read this before handling the products. For safety instructions and 3/4/5-port solenoid valve precautions, refer to the “Handling Precautions for SMC Products” and the “Operation Manual” on the SMC website: <https://www.smc.eu>

How to Use Plug Connector

⚠ Caution

1. Attaching and detaching connectors

- To attach a connector, hold the lever and connector unit between your fingers and insert straight onto the pins of the solenoid valve so that the lever's pawl is pushed into the groove and locks.
- To detach a connector, remove the pawl from the groove by pushing the lever downward with your thumb, and pull the connector straight out.

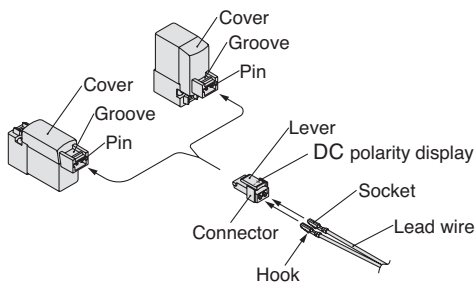

2. Crimping of lead wires and sockets

Strip 3.2 to 3.7 mm at the end of the lead wires, insert the ends of the core wires evenly into the sockets, and then crimp with a crimping tool. When this is done, take care that the coverings of the lead wires do not enter the core wire crimping area.

Use an exclusive crimping tool for crimping.
(Contact SMC for special crimping tools.)

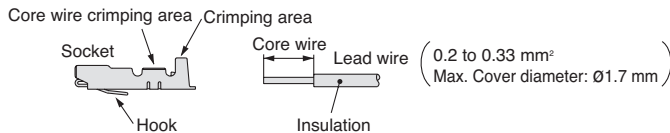

3. Attaching and detaching sockets with lead wires

• Attaching

Insert the sockets into the square holes of the connector (+, - indication), and continue to push the sockets all the way in until they lock by hooking into the seats in the connector. (When they are pushed in, their hooks open and they are locked automatically.) Then confirm that they are locked by pulling lightly on the lead wires.

• Detaching

To detach a socket from a connector, pull out the lead wire while pressing the socket's hook with a stick having a thin tip (approx. 1 mm). If the socket will be used again, first spread the hook outward.

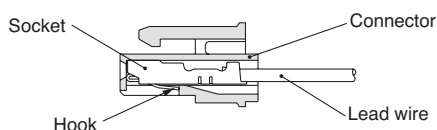

Plug Connector Lead Wire Length

⚠ Caution

Standard length is 300 mm, but the following lengths are also available.

How to Order Connector Assembly

For DC: **SY100-30-4A** -

Without lead wire: **SY100-30-A**
(with connector and 2 of sockets only)

• Lead wire length

	Lead wire length
-	300 mm
6	600 mm
10	1000 mm
15	1500 mm
20	2000 mm
25	2500 mm
30	3000 mm
50	5000 mm

How to Order

Include the connector assembly part number together with the part number for the plug connector's solenoid valve without connector.

Ex.) In case of 2000 mm of lead wire

For DC
SYJ3120-5LO-M3
SY100-30-4A-20



Series SYJ3000/5000/7000 Specific Product Precautions 3

Be sure to read this before handling the products. For safety instructions and 3/4/5-port solenoid valve precautions, refer to the "Handling Precautions for SMC Products" and the "Operation Manual" on the SMC website: <https://www.smc.eu>

Surge Voltage Suppressor

Caution

<For DC>

Grommet, L/M Plug Connector

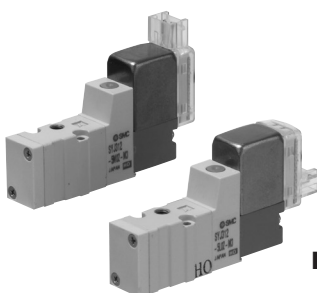

Standard type (with polarity)

Surge voltage suppressor (□S)

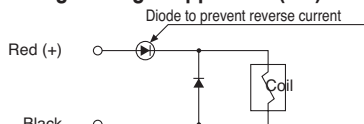

With light/surge voltage suppressor (□Z)

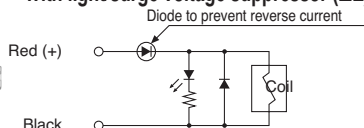

Non-polar type

With surge voltage suppressor (□R)

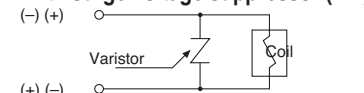

With light/surge voltage suppressor (□U)

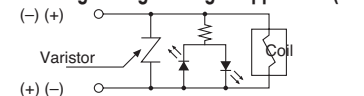

- Connect the standard type in accordance with the +, - polarity indication. (The non-polar type can be used with the connections made either way.)
- Since voltage specifications other than standard 24 V and 12 VDC do not have diodes for polarity protection, be careful not to make errors in the polarity.
- Please use caution regarding the allowable voltage fluctuation because there is about a 1 volt drop for a valve with polarity protection. (For details, refer to the solenoid specifications for the individual valve.)
- When wiring is done at the factory, positive (+) is red and negative (-) is black.

With power saving circuit

Power consumption is decreased by 1/4 by reducing the wattage required to hold the valve in an energised state. (Effective energising time is over 62 ms at 24 VDC.)

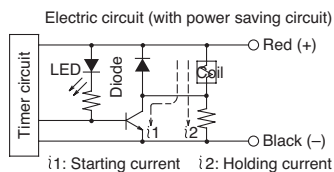

Operating Principle

With the above circuit, the current consumption when holding is reduced to save energy. Please refer to the electric wave data to the right.

- Please be careful not to reverse the polarity, since a diode to prevent the reversed current is not provided for the power saving circuit.
- Please use caution regarding the allowable voltage fluctuation because there is about a 0.5 volt drop due to the transistor. (For details, refer to the solenoid specifications for the individual valve.)

(In the case of SYJ3□□T, the electric wave form of energy saving type)

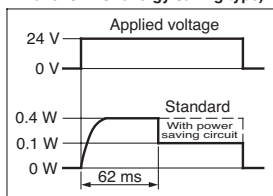

DIN Terminal

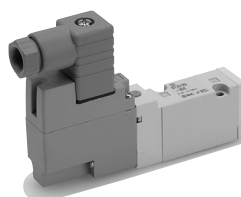

DIN terminal has no polarity.

With surge voltage suppressor (DS)

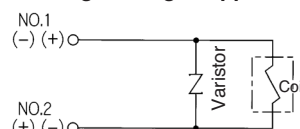

With light/surge voltage suppressor (DZ)

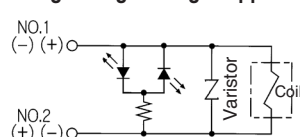

M8 Connector

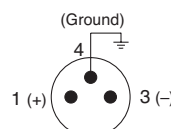

Solenoid valve side pin wiring diagram (For W type)

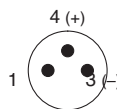

Solenoid valve side pin wiring diagram (For WA type)

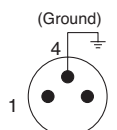

Solenoid valve side pin wiring diagram (For W type)

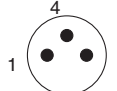

Solenoid valve side pin wiring diagram (For WA type)

Standard type (with polarity)

With light/surge voltage suppressor (□S)

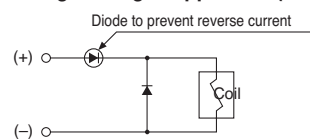

With light/surge voltage suppressor (□Z)

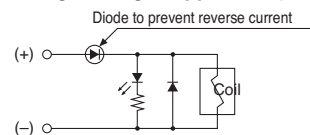

Non-polar type

With surge voltage suppressor (□R)

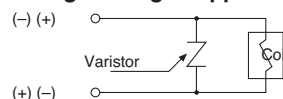

With light/surge voltage suppressor (□U)

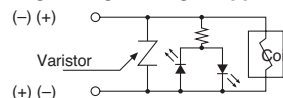

- In the case of standard type, connect + to 1 and - to 3 for W type, and connect + to 4 and - to 3 for WA type, according to the polarity.
- For DC voltages other than 12 V and 24 V, incorrect wiring will cause damage to the surge suppressor circuit.
- Please use caution regarding the allowable voltage fluctuation because there is about a 1 volt drop for a valve with polarity protection. (For details, refer to the solenoid specifications for the individual valve.)



Series SYJ3000/5000/7000 Specific Product Precautions 4

Be sure to read this before handling the products. For safety instructions and 3/4/5-port solenoid valve precautions, refer to the “Handling Precautions for SMC Products” and the “Operation Manual” on the SMC website: <https://www.smc.eu>

Surge Voltage Suppressor

<For AC>

(There is no “S” type because the generation of surge voltage is prevented by a rectifier.)

DIN Terminal

With light (DZ)

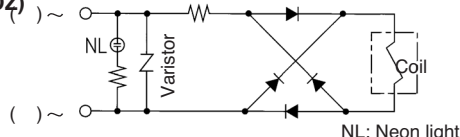

Note) Surge voltage suppressor of varistor has residual voltage corresponding to the protective element and rated voltage; therefore, protect the controller side from the surge. The residual voltage of the diode is approximately 1 V.

How to Use DIN Terminal

⚠ Caution

Connection

1. Loosen the holding screw and pull the connector out of the solenoid valve terminal block.
2. After removing the holding screw, insert a flat head screwdriver, etc. into the notch on the bottom of the terminal block and pry it open, separating the terminal block and the housing.
3. Loosen the terminal screws (slotted screws) on the terminal block, insert the cores of the lead wires into the terminals according to the connection method, and fasten them securely with the terminal screws.

⚠ Caution

When making connections, take note that using other than the supported size ($\phi 3.5$ to $\phi 7$) heavy duty cord will not satisfy IP65 (enclosure) standards. Also, be sure to tighten the ground nut and holding screw within their specified torque ranges.

⚠ Caution

Changing the entry direction

After separating the terminal block and housing, the cord entry can be changed by attaching the housing in the desired direction (4 directions at 90 intervals).

* When equipped with a light, be careful not to damage the light with the cord's lead wires.

Precautions

Plug in and pull out the connector vertically without tilting to one side.

Compatible cable

Cord O.D.: $\phi 3.5$ to $\phi 7$

(Reference) 0.5 mm^2 , 2-core or 3-core, equivalent to JIS C 3306

How to Use DIN Terminal

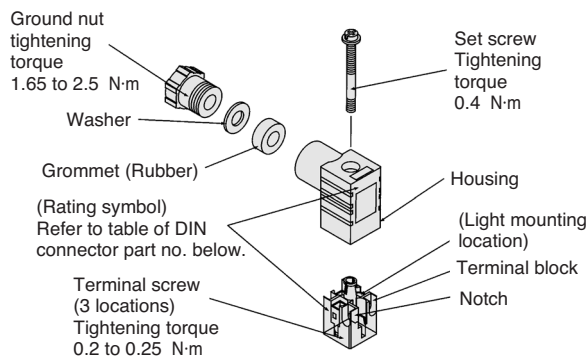

Type “Y”

DIN connector type Y is a DIN connector that conforms to the DIN pitch 8-mm standard.

- D type DIN connector with 9.4 mm pitch between terminals is not interchangeable.
- To distinguish from the D type DIN connector, “N” is listed at the end of voltage symbol. (For connector parts without lights, “N” is not indicated. Please refer to the name plate to distinguish.)
- Dimensions are completely the same as D type DIN connector.
- When exchanging the pilot valve assembly only, “V115-□D” is interchangeable with “V115-□Y”. Do not replace V111 (G, L, M) to V115-□D/□Y (DIN terminal), and vice versa.

DIN Connector Part No.

⚠ Caution

<Type D>

Without light	SY100-61-1	
Rated voltage	Voltage symbol	Part no.
24 VDC	24V	SY100-61-3-05
12 VDC	12V	SY100-61-3-06
100 VAC	100V	SY100-61-2-01
200 VAC	200V	SY100-61-2-02
110 VAC	110V	SY100-61-2-03
220 VAC	220V	SY100-61-2-04

<Type Y>

Without light	SY100-82-1	
Rated voltage	Voltage symbol	Part no.
24 VDC	24VN	SY100-82-3-05
12 VDC	12VN	SY100-82-3-06
100 VAC	100VN	SY100-82-2-01
200 VAC	200VN	SY100-82-2-02
110 VAC(115 VAC)	110VN	SY100-82-2-03
220 VAC(230 VAC)	220VN	SY100-82-2-04

Circuit Diagram with Light

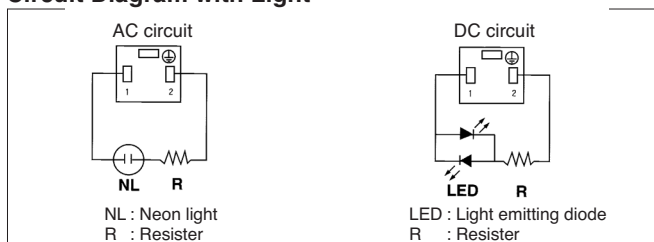

Note) Refer to page 80 for DIN connector (Y) conforming to EN-175301-803C (former DIN 43650C).



Series SYJ3000/5000/7000 Specific Product Precautions 5

Be sure to read this before handling the products. For safety instructions and 3/4/5-port solenoid valve precautions, refer to the “Handling Precautions for SMC Products” and the “Operation Manual” on the SMC website: <https://www.smc.eu>

Connector Assembly with Cover

⚠ Caution

Connector assembly with dust proof protective cover.

- Effective to prevention of short circuit failure due to the entry of foreign matter into the connector.
- Chloroprene rubber for electrical use, which provides outstanding weather resistance and electrical insulation, is used for the cover material. However, do not allow contact with cutting oil, etc.
- Simple and unencumbered appearance by adopting round-shaped cord.

How to Order

SY100-68-A-

• Lead wire length

-	300 mm
6	600 mm
10	1000 mm
15	1500 mm
20	2000 mm
25	2500 mm
30	3000 mm
50	5000 mm

Connector Assembly with Cover: Dimensions

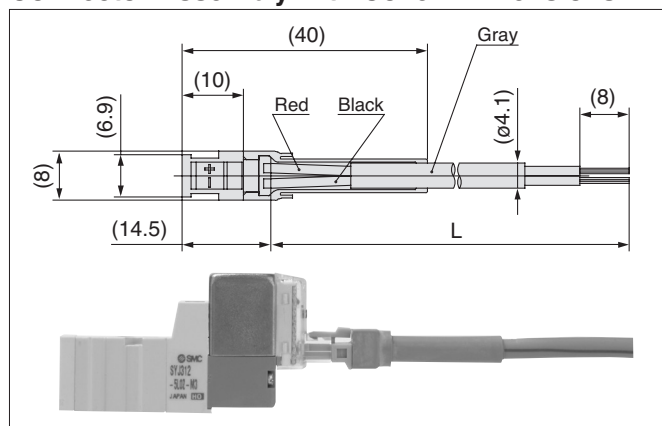

How to Order

Enter the part number for a plug connector solenoid valve without connector together with the part number for a connector assembly with cover.

Ex. 1) Lead wire length of 2000 mm

SYJ3120-5LOZ-M3-Q

SY100-68-A-20

Ex. 2) Lead wire length of 300 mm (standard)

SYJ3120-5LPZ-M3-Q

Symbol for connector assembly with cover

* In this case, the part number for the connector assembly with cover is not required.

M8 Connector

⚠ Caution

1. M8 connector types have an IP65 (enclosure) rating, offering protection from dust and water. However please note: these products are not intended for use in water. Select a SMC connector cable (V100-49-1-□) or a FA sensor type connector, with M8 threaded 3 pin specifications conforming to Nippon Electric Control Equipment Association Standard, NECA4202 (IEC60947-5-2). Make sure the connector O.D. is 10.5 mm or less when used with the Series SYJ3000 manifold. If more than 10.5 mm, it cannot be mounted due to the size.
2. Do not use a tool to mount the connector, as this may cause damage. Only tighten by hand. (0.4 to 0.6 Nm)
3. The excessive stress on the cable connector will not be able to satisfy the IP65 rating. Please use caution and do not apply a stress of 30 N or greater.

⚠ Caution

Failure to meet IP65 performance may result if using alternative connectors than those shown above, or when insufficiently tightened.

- Connector cable mounting

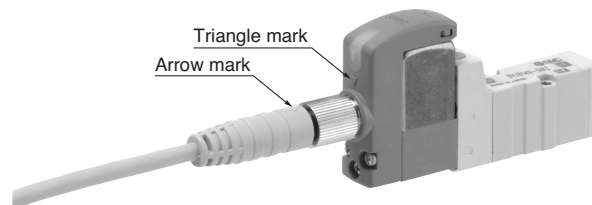

Note) Connector cable should be mounted in the correct direction. Make sure that the arrow symbol on the connector is facing the triangle symbol on the valve when using SMC connector cable (V100-49-1-□). Be careful not to squeeze it in the wrong direction, as problems such as pin damage may occur.

■ Connector cable

- M8 connector cable for M8 can be ordered as follows:

How to Order

1. To order solenoid valve and connector cable at the same time. (Connector cable will be included in the shipment of the solenoid valve.)

SYJ³₅□□□-□□□□-□□□-**Q**

↓ Electrical entry

W1, WA1: Cable length 300 mm

W2, WA2: Cable length 500 mm

W3, WA3: Cable length 1000 mm

W4, WA4: Cable length 2000 mm

W7, WA7: Cable length 5000 mm

Ex. 1) Cable length: 300 mm

SYJ3120-5W1ZE-M3-Q

↓ Symbol for electrical entry

Series SYJ3000/5000/7000 Specific Product Precautions 6



Be sure to read this before handling the products. For safety instructions and 3/4/5-port solenoid valve precautions, refer to the “Handling Precautions for SMC Products” and the “Operation Manual” on the SMC website: <https://www.smc.eu>

M8 Connector

2. To order connector cable only

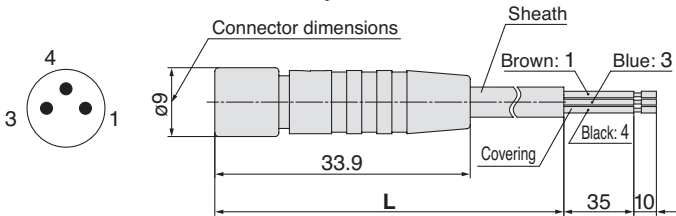

Cable length (L)	No.
300 mm	V100-49-1-1
500 mm	V100-49-1-2
1000 mm	V100-49-1-3
2000 mm	V100-49-1-4
5000 mm	V100-49-1-7

Sheath O.D.	ø3.4 mm
Cover diameter	ø1.16 mm
Conductor area	0.16 mm ²

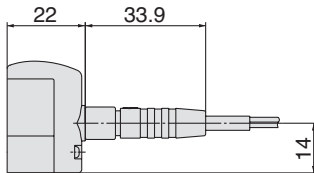

Flat Ribbon Cable Manifold

Caution

Type 21P

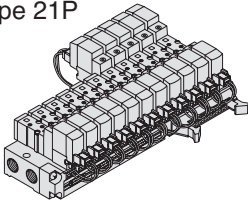

Type 32P

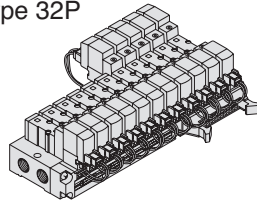

- In the manifold valves, the wiring to the individual valves is provided on a printed circuit board, and the connection to the external wires is consolidated through the use of a flat cable.
- A single MIL flat cable connects the entire manifold to your power source. This greatly reduces installation time.

Flat Ribbon Cable Manifold

Manifold Internal Wiring

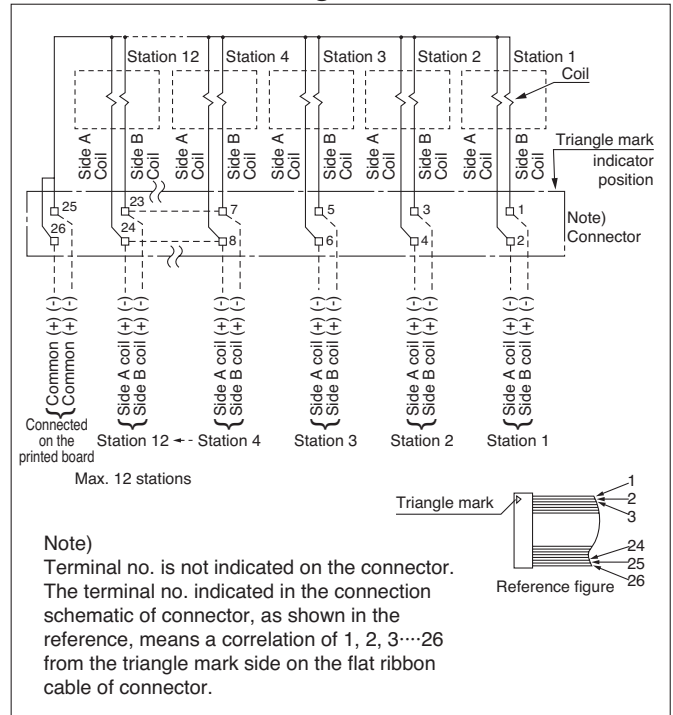

- For more than 10 stations, both poles of the common should be wired.
- For single solenoid, connect to the solenoid B side.
- The maximum number of stations that can be accommodated is 12. For more stations, contact SMC.
- Only non-polar valves are available for the DC flat cable manifold, therefore negative COM or positive COM wiring of the manifold is possible. The valve does not switch with negative COM if a Z type is used. Be sure to use a positive COM.

Bracket

Caution

For bracket attached styles of SYJ3000 (Single) and SYJ7000, do not use it without bracket.

Replacement of Pilot Valve

Caution

Mount it so that there is no slippage or deformation in gaskets, and tighten with the tightening torque as shown below.

Model	Thread size	Tightening torque
SYJ3000	M1.7	0.12 N·m
SYJ5000	M2.5	0.45 N·m
SYJ7000	M3	0.8 N·m



Series SYJ3000/5000/7000 Specific Product Precautions 7

Be sure to read this before handling the products. For safety instructions and 3/4/5-port solenoid valve precautions, refer to the “Handling Precautions for SMC Products” and the “Operation Manual” on the SMC website: <https://www.smc.eu>

Replacement of Pilot Valve

Caution

Pilot valves in this series are improved to provide excellent energy saving results. However following this improvement, these new valves are no longer compatible with the conventional pilot valve used at the interface. Consult with SMC when you need to exchange these pilot valves, in the case of manual override (marked in orange) of the adapter plate.

New type

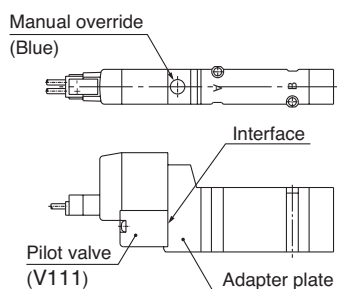

Conventional type

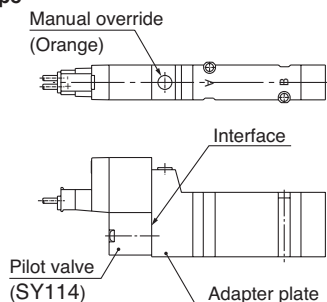

Interface Regulator

Caution

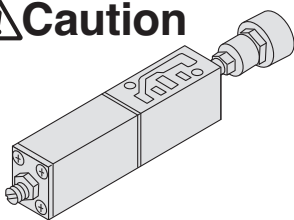

Spacer type regulating valve on manifold block can regulate the pressure to the valve individually.

Specifications

Interface regulator	ARBYJ5000	ARBYJ7000	
Applicable solenoid valve model	SYJ5000	SYJ7000	
Regulating port	P	P	
Proof pressure	1.5 MPa		
Maximum operating pressure	1.0 MPa		
Set pressure range	0.05 to 0.7 MPa ^{Note 1)}		
Ambient and fluid temperature	-5 to 60C (No freezing) ^{Note 2)}		
Thread size for connection of pressure gauge	M5		
Weight (kg)	0.06	0.09	
Effective area at exhaust ^{Note 3)} side (mm ²) S at P ₁ = 0.7 MPa, P ₂ = 0.5 MPa	P→A	1.9	5.1
	P→B	2.1	5.8
Effective area at supply ^{Note 3)} side (mm ²) S at P ₁ = 0.7 MPa, P ₂ = 0.5 MPa	A→EA	4.5	12.6
	B→EB	4.5	12.6

Interface Regulator

Note 1) Set the pressure within the operating pressure range of the solenoid valve.

Note 2) The maximum operating temperature for the solenoid valve is 50C.

Note 3) The effective area listed is for a single solenoid 2 position valve mounted on a sub-plate.

Note 4) Apply pressure from P port in the base for interface regulator.

Flow Characteristics

(P → A) Condition: Inlet pressure 0.7 MPa

● ARBYJ5000-00-P-Q

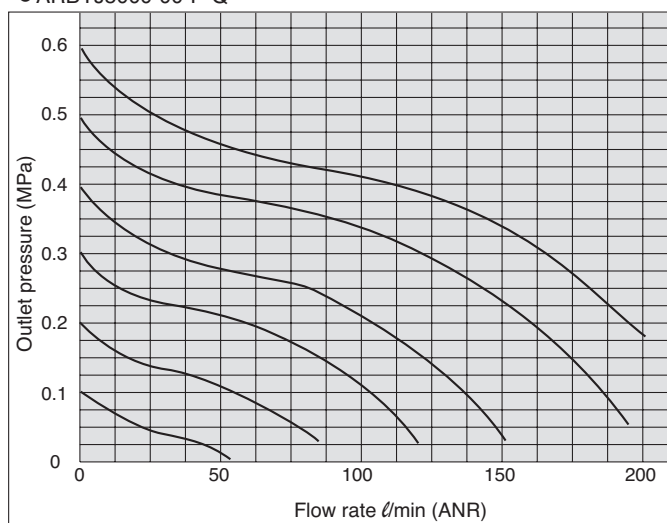

● ARBYJ7000-00-P-Q

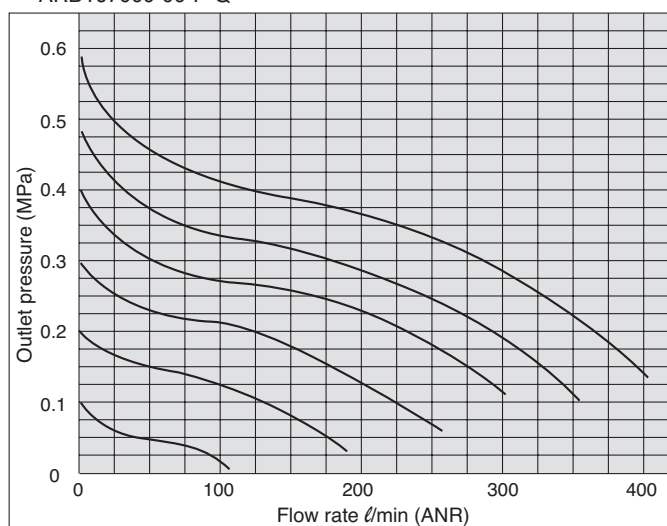

Safety Instructions

These safety instructions are intended to prevent hazardous situations and/or equipment damage. These instructions indicate the level of potential hazard with the labels of “Caution,” “Warning” or “Danger.” They are all important notes for safety and must be followed in addition to International Standards (ISO/IEC) ¹⁾, and other safety regulations.

Caution:

Caution indicates a hazard with a low level of risk which, if not avoided, could result in minor or moderate injury.

Warning:

Warning indicates a hazard with a medium level of risk which, if not avoided, could result in death or serious injury.

Danger:

Danger indicates a hazard with a high level of risk which, if not avoided, will result in death or serious injury.

- 1) ISO 4414: Pneumatic fluid power – General rules relating to systems.
ISO 4413: Hydraulic fluid power – General rules relating to systems.
IEC 60204-1: Safety of machinery – Electrical equipment of machines.
(Part 1: General requirements)
ISO 10218-1: Manipulating industrial robots - Safety.
etc.

Warning

1. The compatibility of the product is the responsibility of the person who designs the equipment or decides its specifications.

Since the product specified here is used under various operating conditions, its compatibility with specific equipment must be decided by the person who designs the equipment or decides its specifications based on necessary analysis and test results. The expected performance and safety assurance of the equipment will be the responsibility of the person who has determined its compatibility with the product. This person should also continuously review all specifications of the product referring to its latest catalogue information, with a view to giving due consideration to any possibility of equipment failure when configuring the equipment.

2. Only personnel with appropriate training should operate machinery and equipment.

The product specified here may become unsafe if handled incorrectly. The assembly, operation and maintenance of machines or equipment including our products must be performed by an operator who is appropriately trained and experienced.

3. Do not service or attempt to remove product and machinery/equipment until safety is confirmed.

1. The inspection and maintenance of machinery/equipment should only be performed after measures to prevent falling or runaway of the driven objects have been confirmed.
2. When the product is to be removed, confirm that the safety measures as mentioned above are implemented and the power from any appropriate source is cut, and read and understand the specific product precautions of all relevant products carefully.
3. Before machinery/equipment is restarted, take measures to prevent unexpected operation and malfunction.

4. Contact SMC beforehand and take special consideration of safety measures if the product is to be used in any of the following conditions.

1. Conditions and environments outside of the given specifications, or use outdoors or in a place exposed to direct sunlight.
2. Installation on equipment in conjunction with atomic energy, railways, air navigation, space, shipping, vehicles, military, medical treatment, combustion and recreation, or equipment in contact with food and beverages, emergency stop circuits, clutch and brake circuits in press applications, safety equipment or other applications unsuitable for the standard specifications described in the product catalogue.
3. An application which could have negative effects on people, property, or animals requiring special safety analysis.
4. Use in an interlock circuit, which requires the provision of double interlock for possible failure by using a mechanical protective function, and periodical checks to confirm proper operation.

Caution

1. The product is provided for use in manufacturing industries.

The product herein described is basically provided for peaceful use in manufacturing industries.

If considering using the product in other industries, consult SMC beforehand and exchange specifications or a contract if necessary. If anything is unclear, contact your nearest sales branch.

Limited warranty and Disclaimer/Compliance Requirements

The product used is subject to the following “Limited warranty and Disclaimer” and “Compliance Requirements”. Read and accept them before using the product.

Limited warranty and Disclaimer

1. The warranty period of the product is 1 year in service or 1.5 years after the product is delivered, whichever is first. ²⁾ Also, the product may have specified durability, running distance or replacement parts. Please consult your nearest sales branch.
2. For any failure or damage reported within the warranty period which is clearly our responsibility, a replacement product or necessary parts will be provided. This limited warranty applies only to our product independently, and not to any other damage incurred due to the failure of the product.
3. Prior to using SMC products, please read and understand the warranty terms and disclaimers noted in the specified catalogue for the particular products.
- 2) Vacuum pads are excluded from this 1 year warranty. A vacuum pad is a consumable part, so it is warranted for a year after it is delivered. Also, even within the warranty period, the wear of a product due to the use of the vacuum pad or failure due to the deterioration of rubber material are not covered by the limited warranty.

Compliance Requirements

1. The use of SMC products with production equipment for the manufacture of weapons of mass destruction (WMD) or any other weapon is strictly prohibited.
2. The exports of SMC products or technology from one country to another are governed by the relevant security laws and regulations of the countries involved in the transaction. Prior to the shipment of a SMC product to another country, assure that all local rules governing that export are known and followed.

Caution

SMC products are not intended for use as instruments for legal metrology.

Measurement instruments that SMC manufactures or sells have not been qualified by type approval tests relevant to the metrology (measurement) laws of each country. Therefore, SMC products cannot be used for business or certification ordained by the metrology (measurement) laws of each country.

Safety Instructions

Be sure to read “Handling Precautions for SMC Products” (M-E03-3) before using.

SMC Corporation (Europe)

Austria	+43 (0)2262622800	www.smc.at	office.at@smc.com
Belgium	+32 (0)33551464	www.smc.be	info@smc.be
Bulgaria	+359 (0)2807670	www.smc.bg	sales.bg@smc.com
Croatia	+385 (0)13707288	www.smc.hr	sales.hr@smc.com
Czech Republic	+420 541424611	www.smc.cz	office.at@smc.com
Denmark	+45 70252900	www.smc.dk.com	smc.dk@smc.com
Estonia	+372 651 0370	www.smcee.ee	info.ee@smc.com
Finland	+358 207513513	www.smc.fi	smc.fi@smc.com
France	+33 (0)164761000	www.smc-france.fr	supportclient.fr@smc.com
Germany	+49 (0)61034020	www.smc.de	info.de@smc.com
Greece	+30 210 2717265	www.smchellas.gr	sales@smchellas.gr
Hungary	+36 23513000	www.smc.hu	office.hu@smc.com
Ireland	+353 (0)14039000	www.smcautomation.ie	technical.ie@smc.com
Italy	+39 03990691	www.smcitalia.it	mailbox.it@smc.com
Latvia	+371 67817700	www.smc.lv	info.lv@smc.com



Lithuania	+370 5 2308118	www.smclt.lt	info.lt@smc.com
Netherlands	+31 (0)205318888	www.smc.nl	info@smc.nl
Norway	+47 67129020	www.smc-norge.no	post.no@smc.com
Poland	+48 22 344 40 00	www.smc.pl	office.pl@smc.com
Portugal	+351 214724500	www.smc.eu	apoiocliente.pt@smc.com
Romania	+40 213205111	www.smcromania.ro	office.ro@smc.com
Russia	+7 (812)3036600	www.smc.eu	sales@smcru.com
Slovakia	+421 (0)413213212	www.smc.sk	sales.sk@smc.com
Slovenia	+386 (0)73885412	www.smc.si	office.si@smc.com
Spain	+34 945184100	www.smc.eu	post.es@smc.com
Sweden	+46 (0)86031240	www.smc.nu	order.se@smc.com
Switzerland	+41 (0)523963131	www.smc.ch	helpcenter.ch@smc.com
Turkey	+90 212 489 0 440	www.smcturkey.com.tr	satis.tr@smc.com
UK	+44 (0)845 121 5122	www.smc.uk	sales.gb@smc.com
South Africa	+27 10 900 1233	www.smcza.co.za	Sales.za@smc.com