

# Clean Regulator/Fluoro Resin Type



**Series SRF**

Wetted part materials  
**Body: New PFA**  
**Diaphragm: PTFE**

Recommended maximum flow rate



2 l/min	<b>SRF 10</b>
5 l/min	<b>SRF 30</b>
20 l/min	<b>SRF 50</b>

Inlet side pressure: 0.3 MPa, Fluid: Water

## Washing/Assembly Procedure

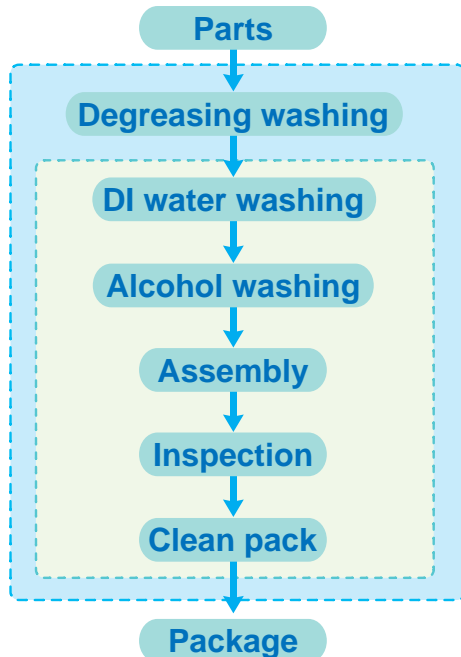
Washing parts: Body, Valve diaphragm and Diaphragm



-  Working atmosphere Class 100
-  Working atmosphere Class 10000

## Construction

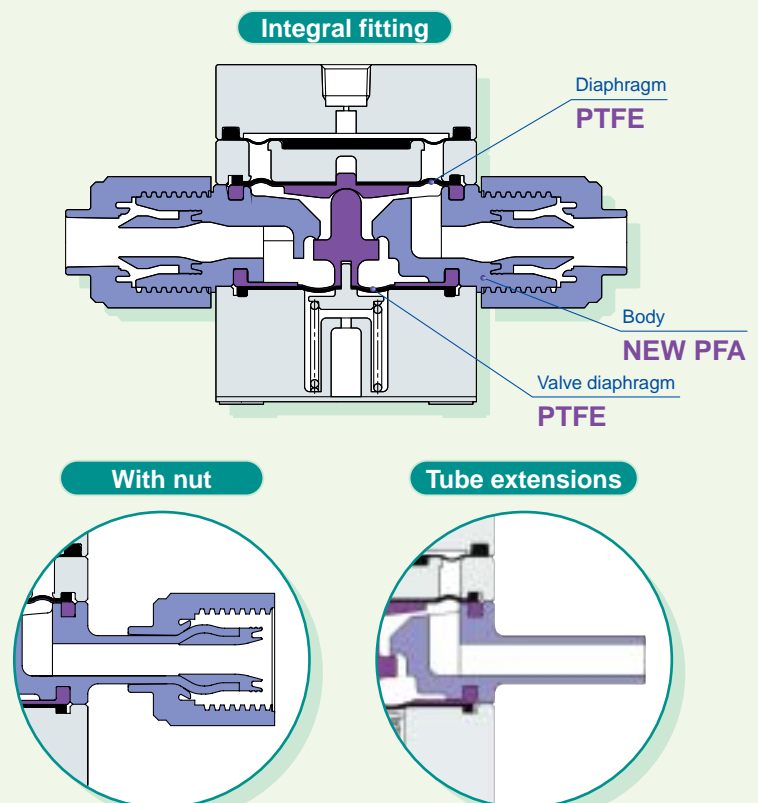

# Clean Regulator/Fluoro Resin Type Series *SRF*

## How to Order

### Integral fitting

SRF **1** 0 – S **07** □



Integral fitting (LQ2)

Pilot port thread type

Nil	Rc1/8
N	NPT1/8

Applicable tubing size (O.D. x I.D.)

Metric size

Symbol	Applicable tubing size	Applicable fitting		
		SRF10	SRF30	SRF50
04	4 x 3	●		
06	6 x 4	○	●	
08	8 x 6		●	
10	10 x 8		○	
12	12 x 10			●
19	19 x 16			○

Inch size

Symbol	Applicable tubing size	Applicable model		
		SRF10	SRF30	SRF50
03	1/8" x 0.086"	●		
05	3/16" x 1/8"	●		
07	1/4" x 5/32"	○	●	
11	3/8" x 1/4"		○	
13	1/2" x 3/8"			●
19	3/4" x 5/8"			○

○: Basic size ●: With reducer

○: Basic size ●: With reducer

Note) Tubing size is interchangeable by replacing the reducer insert bushing nut.

### With nut

SRF **1** 0 S – **1** S **07** **11** □



Fitting type

Symbol	Applicable fitting
1	LQ1
2	LQ2

Body size

1
3
5

Pilot port thread type

Nil	Rc1/8
N	NPT1/8

Fitting size (IN side) • Fitting size (OUT side)

Symbol	Fitting size <sup>Note 2)</sup>	Fitting type	Applicable model		
			SRF10	SRF30	SRF50
07	2	LQ1,2	○		
11	3		●	○	
13	4			●	
19	5				○
25 <sup>Note 1)</sup>	6	LQ1			●

○: Basic size ●: With plug-in reducer

Symbol	Applicable fitting size <sup>Note 2)</sup>	Fitting type	Applicable model		
			SRF10	SRF30	SRF50
Nil	Same as IN side	–	–	–	–
07	2	LQ1,2	○		
11	3		●	○	
13	4			●	
19	5				○
25 <sup>Note 1)</sup>	6	LQ1			●

○: Basic size ●: With reducer

Note 1) Fitting type: LQ1 only

Note 2) Refer to How to Order (LQ□□-S) on page 2 for applicable fittings without nut (LQ type).  
Select fittings of the same type and size as the one fitted to the regulator side.

### Tube extensions

SRF **1** 0 – T **07** □



Body size

1
3
5

Pilot port thread type

Nil	Rc1/8
N	NPT1/8

Tubing size (O.D.)

Symbol	Tubing size	Applicable model
07	1/4"	SRF10
11	3/8"	SRF30
19	3/4"	SRF50

## How to Order Fitting for Model with Nut

How to order fitting for model such as Clean Regulator/Series **SRF□0S**, when one nut (including insert bushing) of the nuts is not attached.

**LQ1 E 21 - S**

Fitting type

One nut (including insert bushing) of the nuts is not attached. Please refer to below Ordering example.

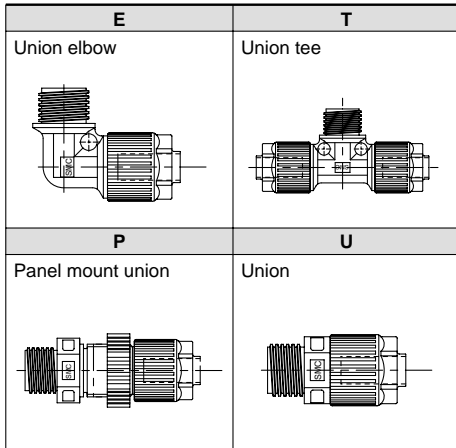

Applicable tubing size

Class	No.	Applicable tubing size (mm)	Reducing
2	1	6 x 4	○
2	2	4 x 3	●
3	1	10 x 8	○
3	2	8 x 6	●
3	3	6 x 4	●
4	1	12 x 10	○
4	2	10 x 8	●
5	1	19 x 16	○
5	2	12 x 10	●
6	1	25 x 22	○
6	2	19 x 16	●

Class	No.	Applicable tubing size (inches)	Reducing
2	A	1/4" x 5/32"	○
2	B	3/16" x 1/8"	●
2	C	1/8" x 0.086"	●
3	A	3/8" x 1/4"	○
3	B	1/4" x 5/32"	●
4	A	1/2" x 3/8"	○
4	B	3/8" x 1/4"	●
5	A	3/4" x 5/8"	○
5	B	1/2" x 3/8"	●
6	A	1" x 7/8"	○
6	B	3/4" x 5/8"	●

○: Basic size ●: With reducer



Note 1) Select fittings of the same size as the one fitted to the regulator side.

**LQ2 E 21 - S**

Fitting type

One nut (including insert bushing) of the nuts is not attached. Please refer to below Ordering example.

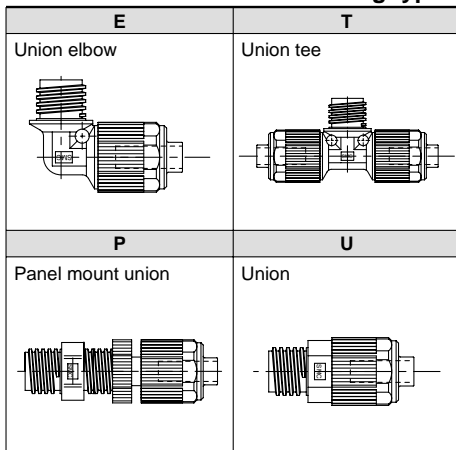

Applicable tubing size

Class	No.	Applicable tubing size (mm)	Reducing
2	1	6 x 4	○
2	2	4 x 3	●
3	1	10 x 8	○
3	2	8 x 6	●
3	3	6 x 4	●
4	1	12 x 10	○
4	2	10 x 8	●
5	1	19 x 16	○
5	2	12 x 10	●

Class	No.	Applicable tubing size (inches)	Reducing
2	A	1/4" x 5/32"	○
2	B	3/16" x 1/8"	●
2	C	1/8" x 0.086"	●
3	A	3/8" x 1/4"	○
3	B	1/4" x 5/32"	●
4	A	1/2" x 3/8"	○
4	B	3/8" x 1/4"	●
5	A	3/4" x 5/8"	○
5	B	1/2" x 3/8"	●

○: Basic size ●: With reducer



Note 1) Select fittings of the same size as the one fitted to the regulator side.

### Ordering example

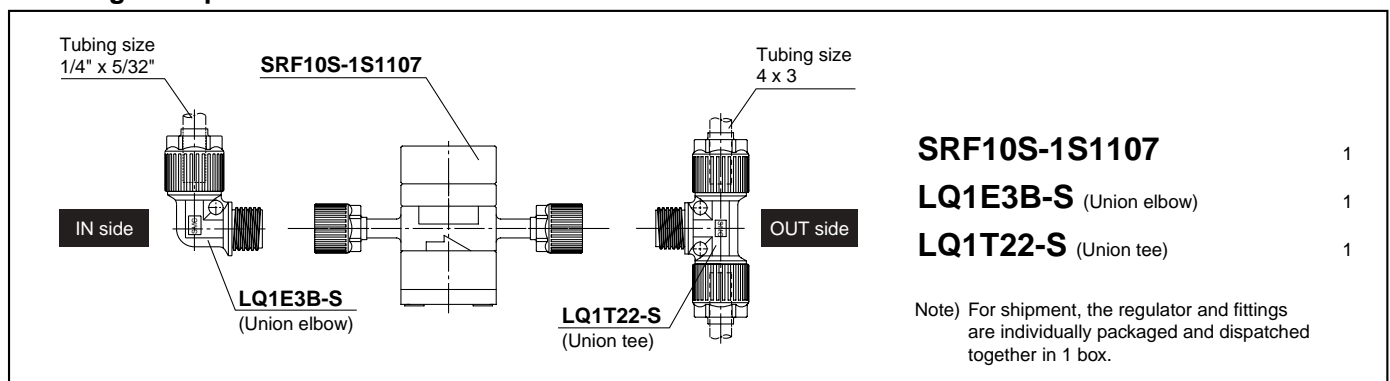

# Series SRF

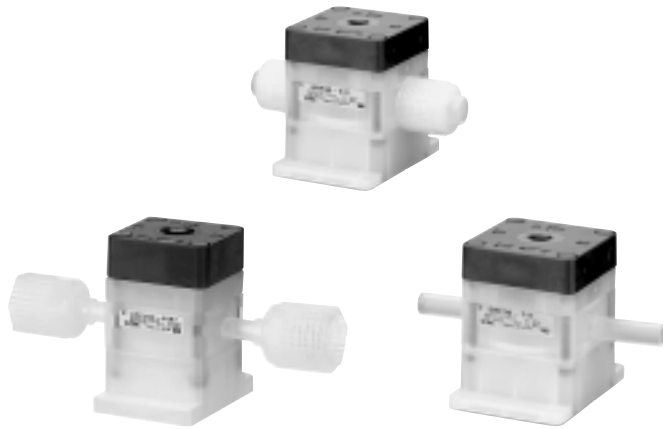

## Specifications

Model		SRF10	SRF30	SRF50
<b>Proof pressure</b>		1.0 MPa		
<b>Maximum operating pressure</b>		0.5 MPa		
<b>Set pressure range</b>		0.02 to 0.4 MPa		
Maximum operating pressure (pilot pressure)		0.5 MPa		
<b>Fluid</b>		Pure water, N <sub>2</sub>		
<b>Ambient and fluid temperature</b>		5 to 60°C		
<b>Valve leakage</b>		10 cm <sup>3</sup> /min or less (fluid: water)		
<b>Weight (kg)</b>	<b>Tubing</b>	0.08	0.24	1.2
	<b>Integral fittings</b>	0.10	0.28	1.3
	<b>With nut</b>			

## Particulate Generation Characteristics

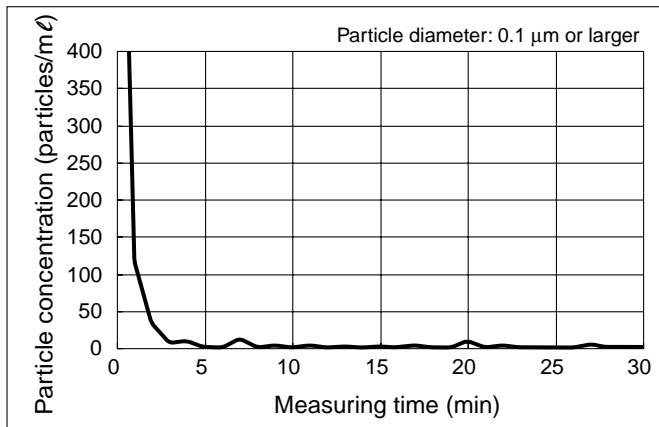

- Test method and conditions  
Particle counters were installed before and after the test sample. The amount of particle generated from the sample is determined by the difference in output values from each counter.  
Flow rate of supplied DI water: 100 ml/min  
Model: SRF30

## Flow-through Characteristics

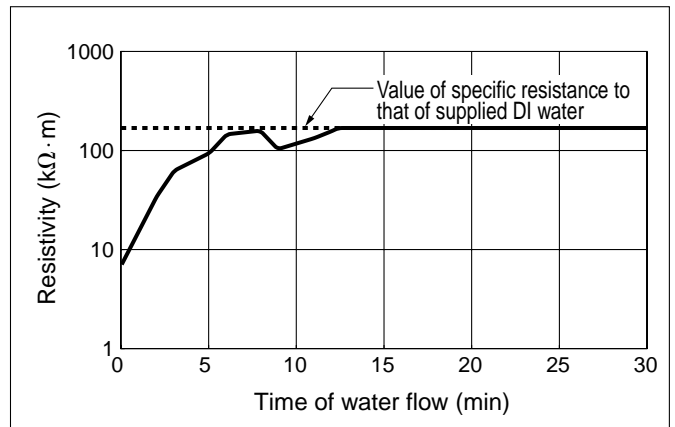

- Test method and conditions  
The liquid contact portions were filled with sulphuric acid and left untouched for half an hour. After the sulphuric acid was drained, the wetted parts are filled with DI water. The specific resistance of the liquid discharged from the outlet side of the sample was measured and recorded.  
Model: SRF30

\*Data provided in this section is just one example of the actually measured values. Application examples illustrated in this flyer do not guarantee the result of applicable use of this product.

## Pressure Fluctuation (Reference value)

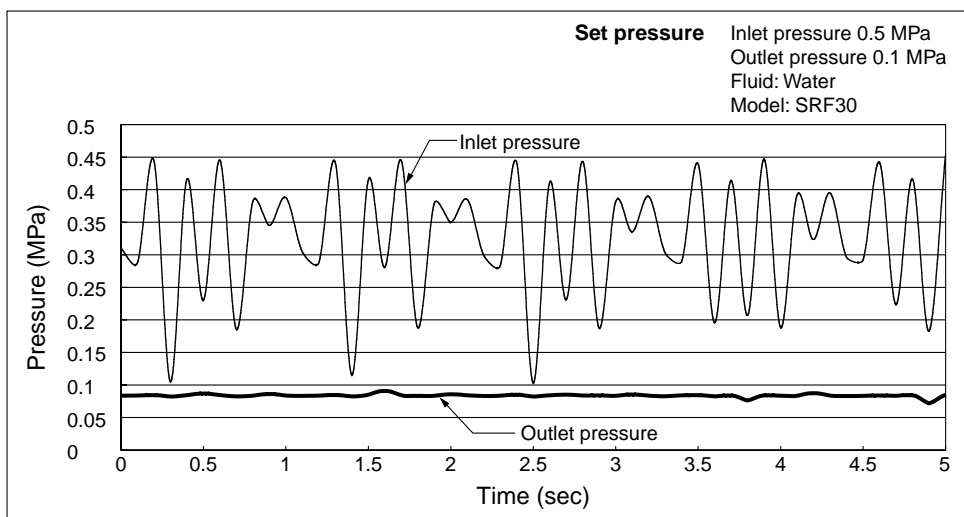

- Test circuit/Conditions

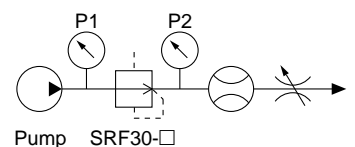

**Pressure Characteristics**

Set pressure Inlet pressure 0.3 MPa  
 Outlet pressure 0.1 MPa Fluid: Water

**SRF10**

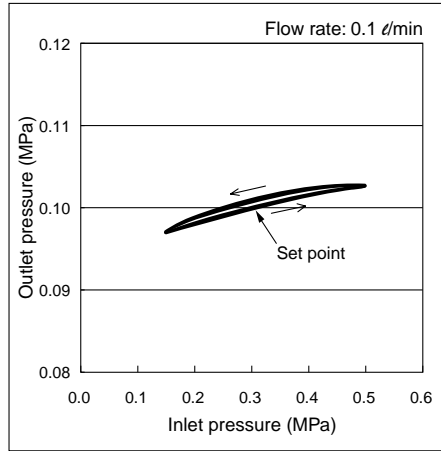

**SRF30**

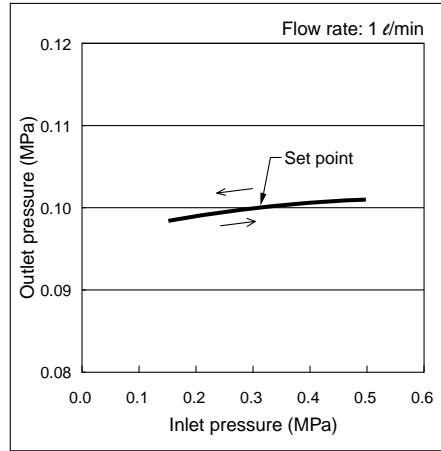

**SRF50**

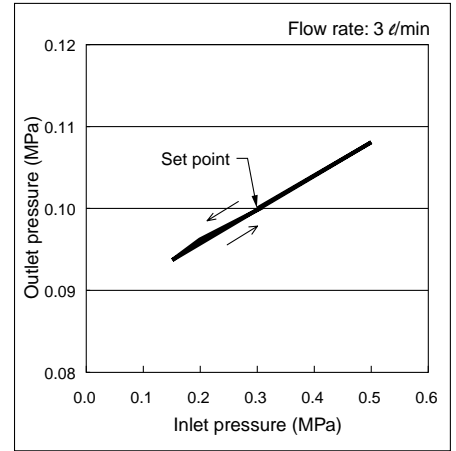

**Flow Characteristics**

Inlet pressure: 0.3 MPa Fluid: Water

**SRF10**

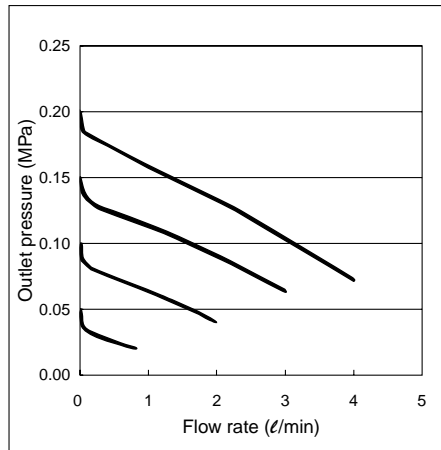

**SRF30**

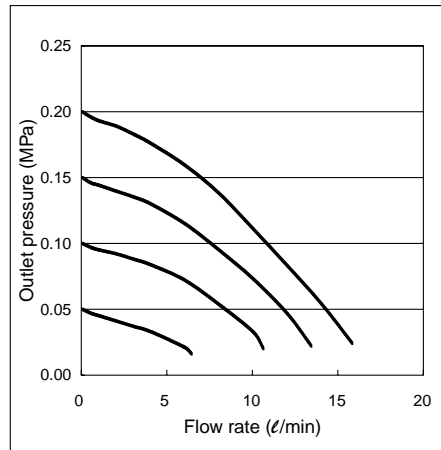

**SRF50**

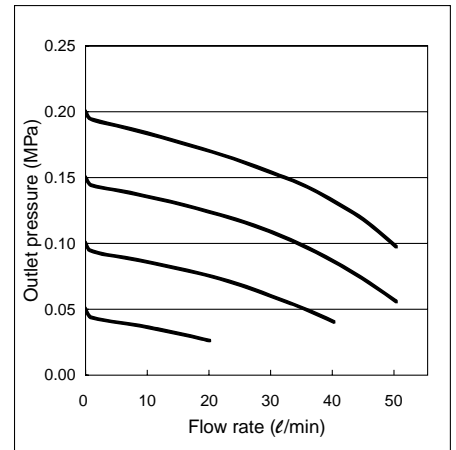

**Input/Output Characteristics**

Inlet pressure: 0.5 MPa Flow rate: 0 l/min (ANR) Fluid: Air

**SRF10**

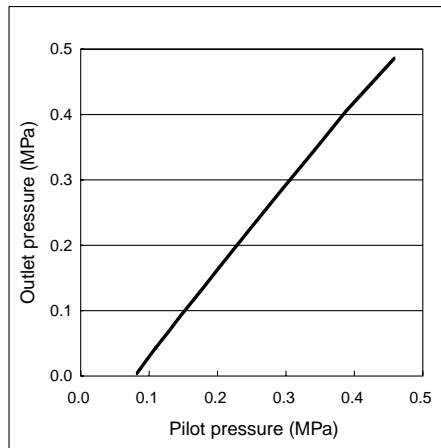

**SRF30**

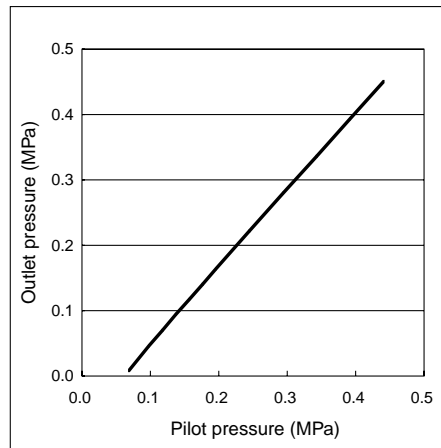

**SRF50**

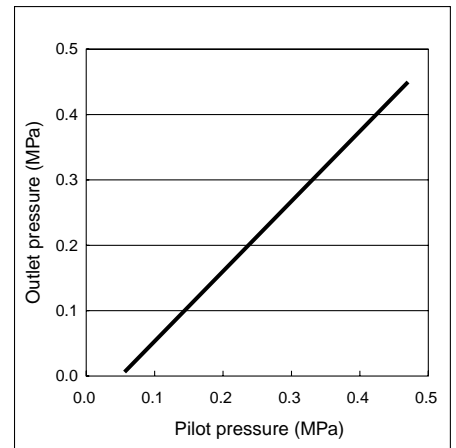

# Series SRF

## Construction/SRF10, 30

### Integral fitting

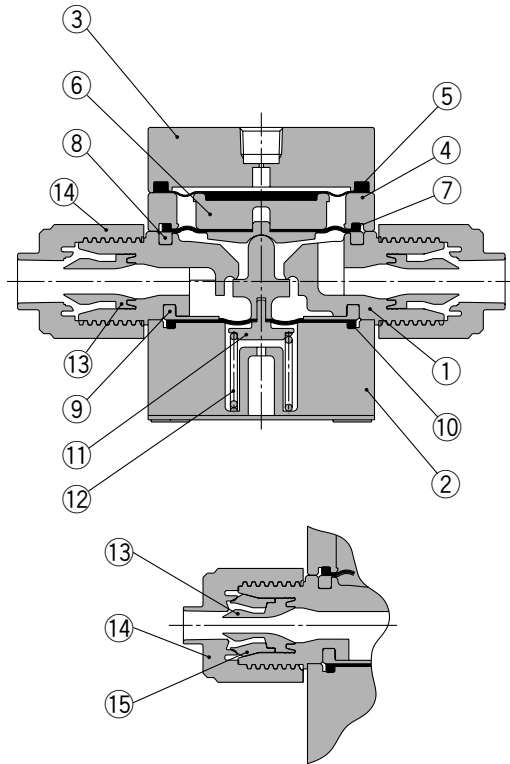

With reducer

### With nut

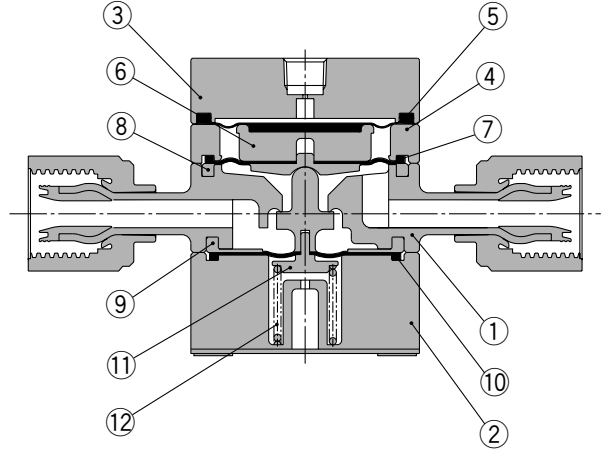

### Tube extensions

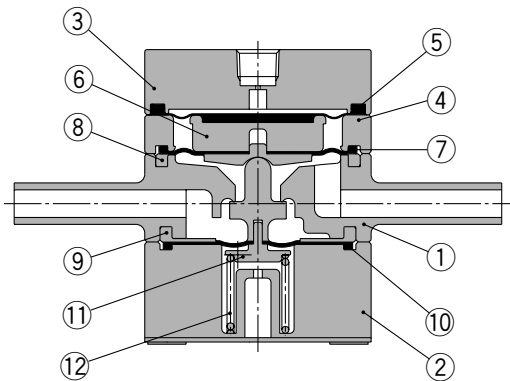

### Parts list

No.	Description	Material	Note
1	Body	New PFA	
2	Valve guide	PVDF	
3	Bonnet	PPS	
4	Spacer	PVDF	
5	Pilot diaphragm	FKM	
6	Diaphragm support	PP	
7	Withstand pressure diaphragm B	FKM	
8	Diaphragm	PTFE	
9	Valve diaphragm	PTFE	
10	Withstand pressure diaphragm A	FKM	
11	Spring holder	Stainless steel 304	Fluoro resin coating
12	Valve spring	Stainless steel 304	Fluoro resin coating

No.	Description	Material	Note
13	Insert bushing	New PFA	
14	Nut	New PFA	
15	Collar	New PFA	

## Construction/SRF50

### SRF50

#### Integral fitting

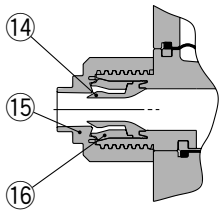
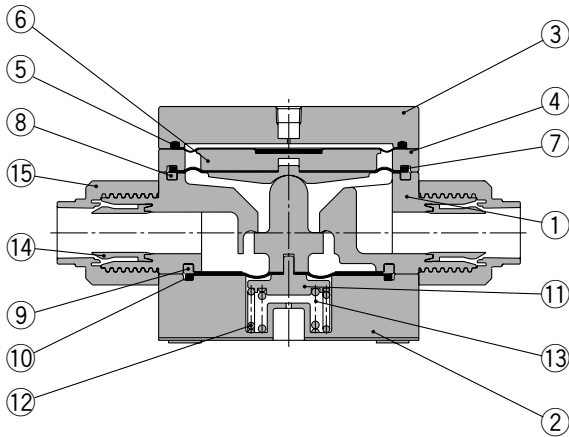

With reducer

#### With nut

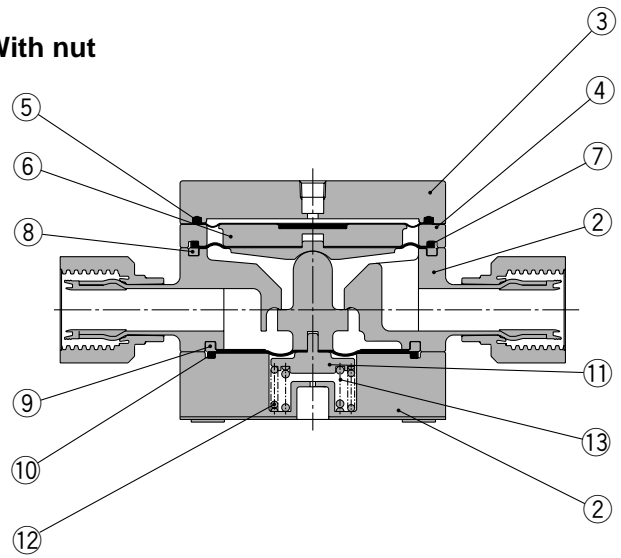

#### Tube extensions

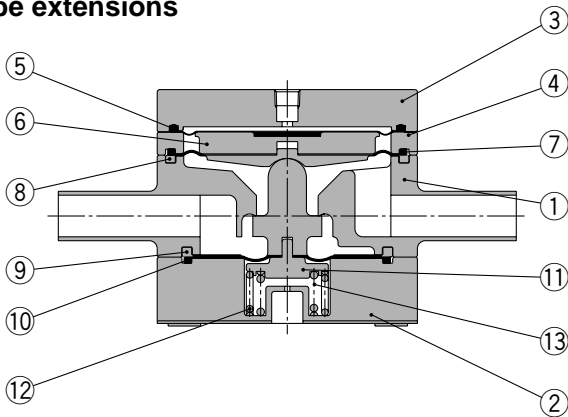

#### Parts list

No.	Description	Material	Note
1	Body	New PFA	
2	Valve guide	PVDF	
3	Bonnet	PPS	
4	Spacer	PVDF	
5	Pilot diaphragm	FKM	
6	Diaphragm support	PP	
7	Withstand pressure diaphragm B	FKM	
8	Diaphragm	PTFE	
9	Valve diaphragm	PTFE	
10	Withstand pressure diaphragm A	FKM	
11	Spring holder	Stainless steel 304	Fluoro resin coating
12	Valve spring 1	Stainless steel 304	Fluoro resin coating
13	Valve spring 2	Stainless steel 304	Fluoro resin coating

No.	Description	Material	Note
14	Insert bushing	New PFA	
15	Nut	New PFA	
16	Collar	New PFA	

# Series SRF

## Dimensions/SRF10

### Integral fitting

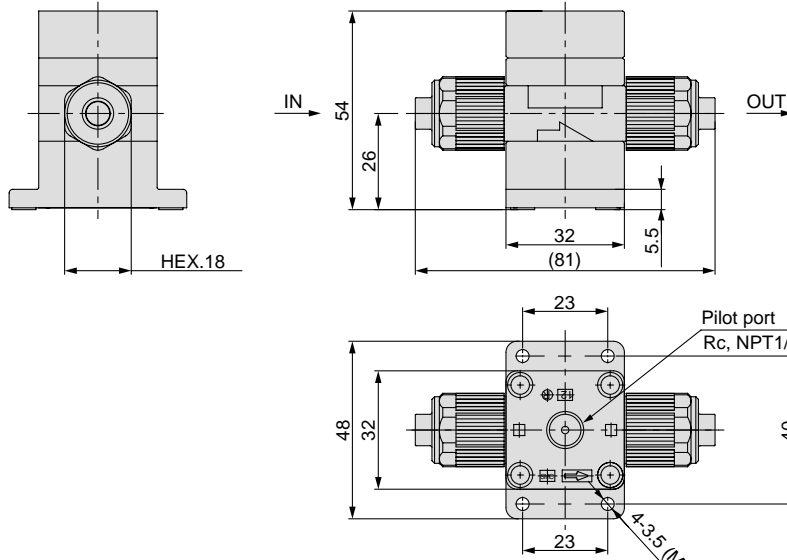

### With nut

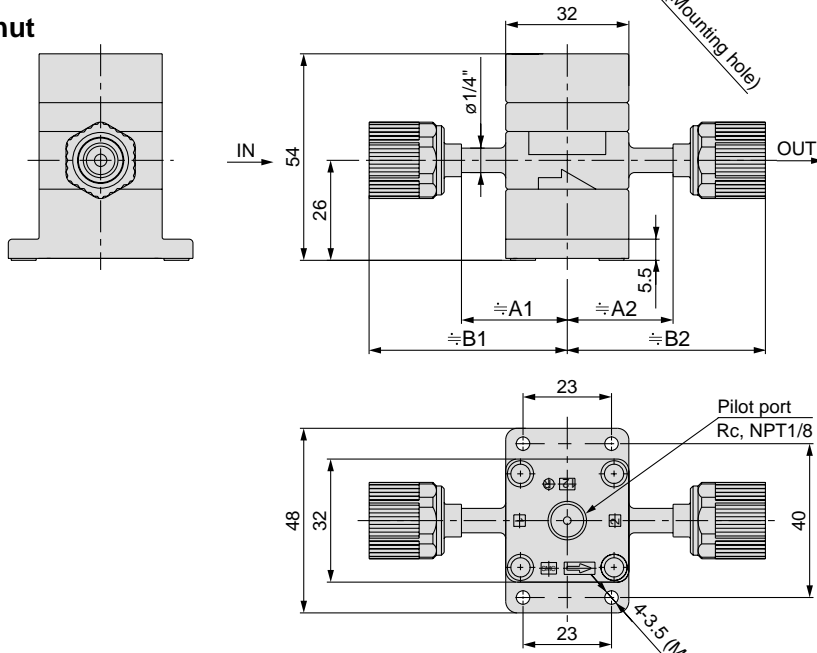

### Tube extensions

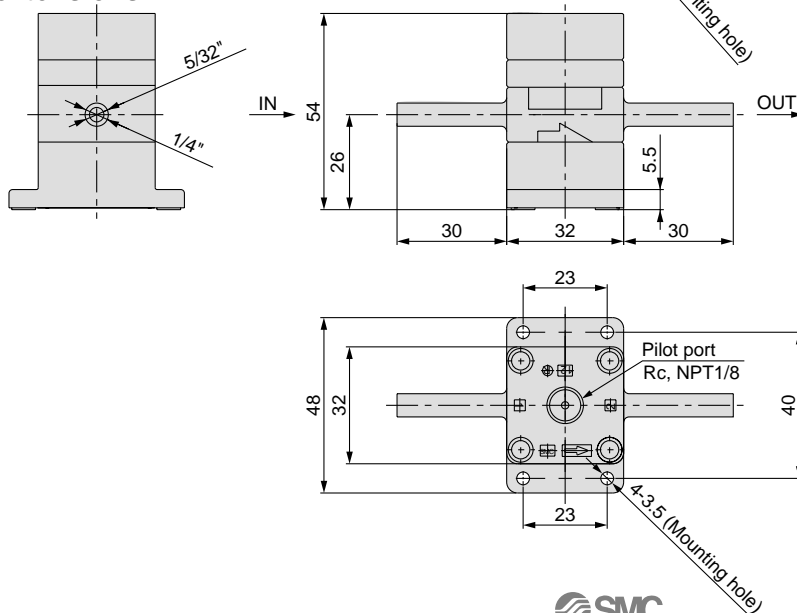

### SRF10

Model	A1	A2	B1	B2
SRF10S-1S07	31	31	48	48
SRF10S-1S0711		28		51
SRF10S-1S11	28	28	51	51
SRF10S-1S1107		31		48
SRF10S-2S07	28	28	52	52
SRF10S-2S0711		27		55
SRF10S-2S11	27	27	55	55
SRF10S-2S1107		28		52

## Dimensions/SRF30

### Integral fitting

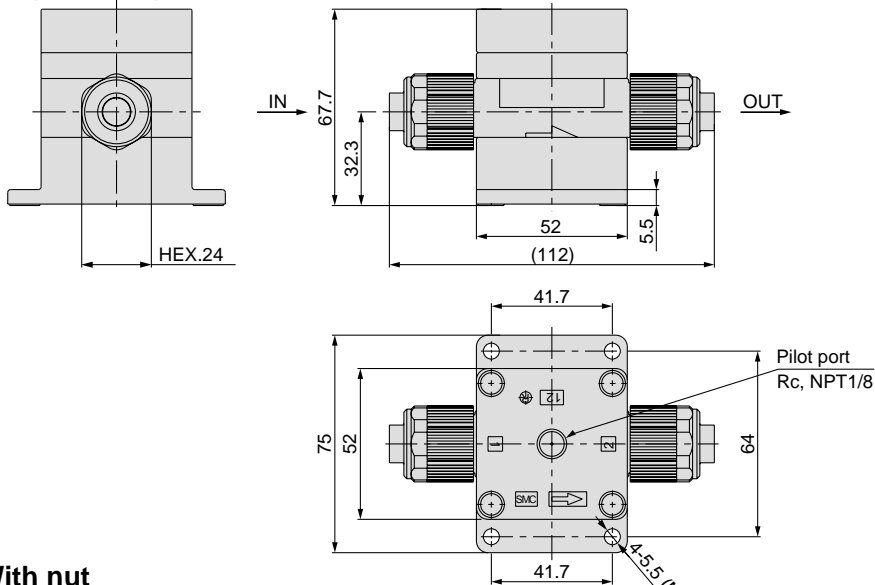

### With nut

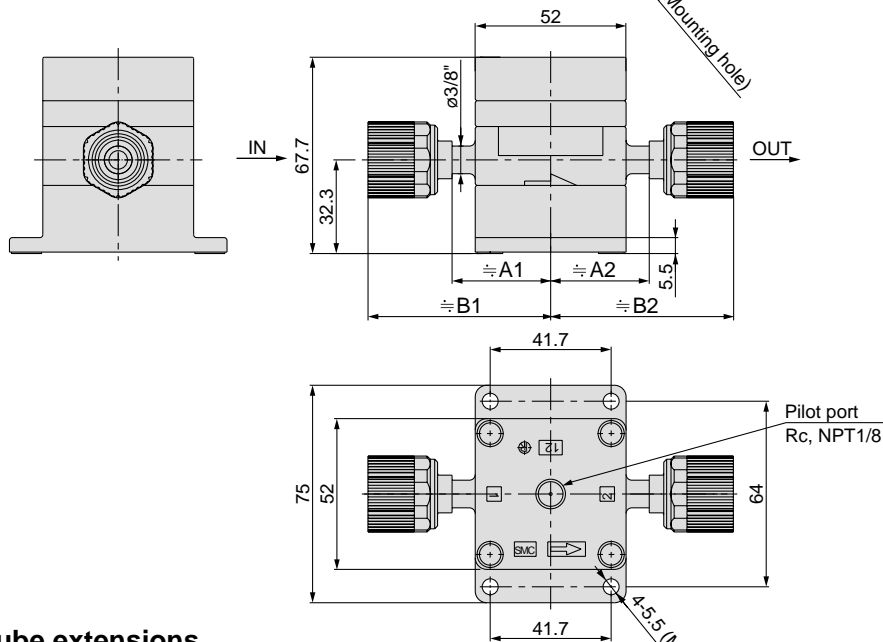

### Tube extensions

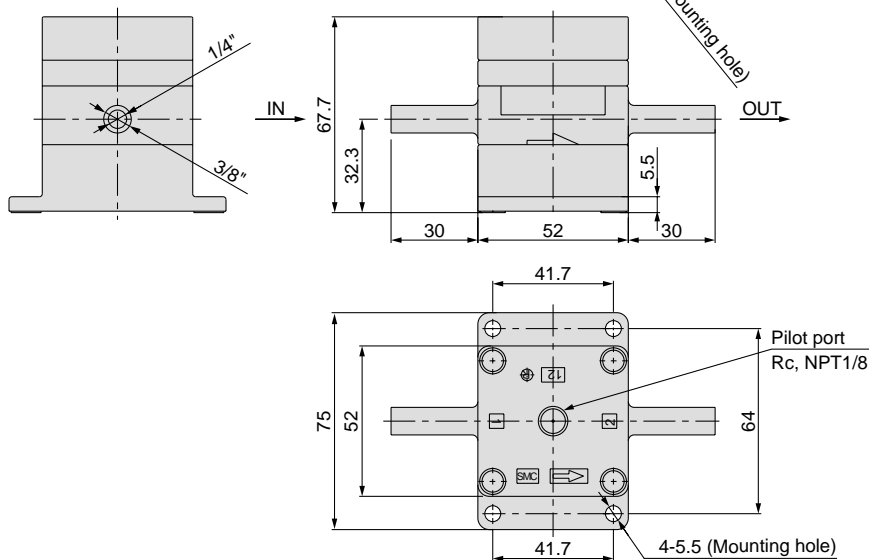

### SRF30

Model	A1	A2	B1	B2
<b>SRF30S-1S11</b>	35	35	58	58
<b>SRF30S-1S1113</b>		34		62
<b>SRF30S-1S13</b>	34	34	62	62
<b>SRF30S-1S1311</b>		35		58
<b>SRF30S-2S11</b>	34	34	63	63
<b>SRF30S-2S1113</b>		32		65
<b>SRF30S-2S13</b>	32	32	65	65
<b>SRF30S-2S1311</b>		34		63

# Series SRF

## Dimensions/SRF50

### Integral fitting

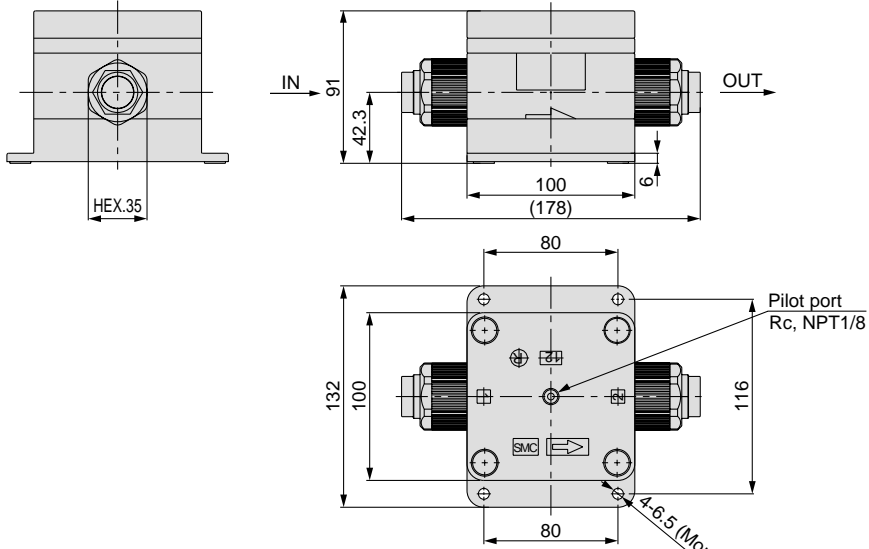

### With nut

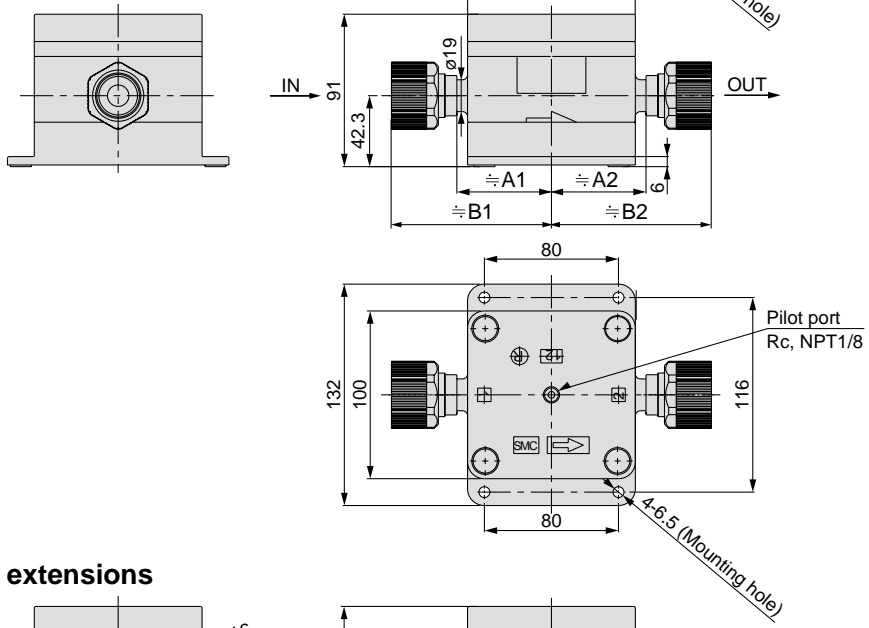

### Tube extensions

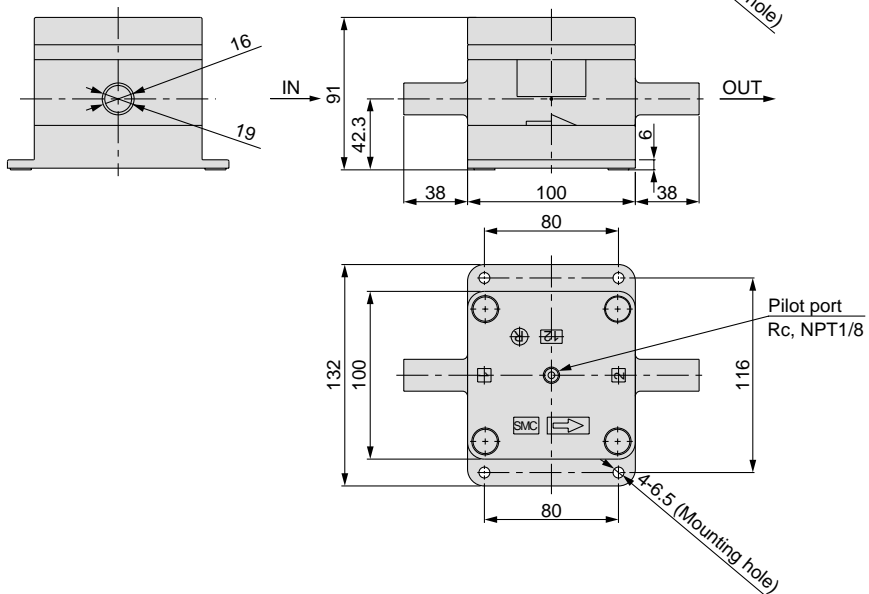

### SRF50

Model	A1	A2	B1	B2
SRF50S-1S19		58		91
SRF50S-1S1925	58	55	91	98
SRF50S-1S25		55		98
SRF50S-1S2519	55	58	98	91
SRF50S-2S19	56	56	95	95

# Series SRF

## Fitting and Special Tools

### Fittings

#### Changing tubing sizes

The tubing size can be changed within the same body class (body size) by replacing the nut and insert bushing.

Body class	Tubing O.D.											
	Metric sizes						Inch sizes					
	4	6	8	10	12	19	1/8"	3/16"	1/4"	3/8"	1/2"	3/4"
2	●	○	—	—	—	—	●	●	○	—	—	—
3	—	●	●	○	—	—	—	—	●	○	—	—
5	—	—	—	—	●	○	—	—	—	—	●	○

#### Parts composition

	Component parts		
	Nut	Insert	Collar (insert assembly)
○ Basic size	Yes	Yes	No
● Reducer type	Yes	Yes	Yes

#### Changing the tubing size

Example) Changing the tubing from an O.D. 1/4" to O.D. 1/8" in body class 2.

Prepare an insert bushing and nut for O.D. 1/8" tubing (LQ-2U03) and change the tubing size.  
(Refer to the section on How to order fitting parts.)

Note) Tubing is sold separately.

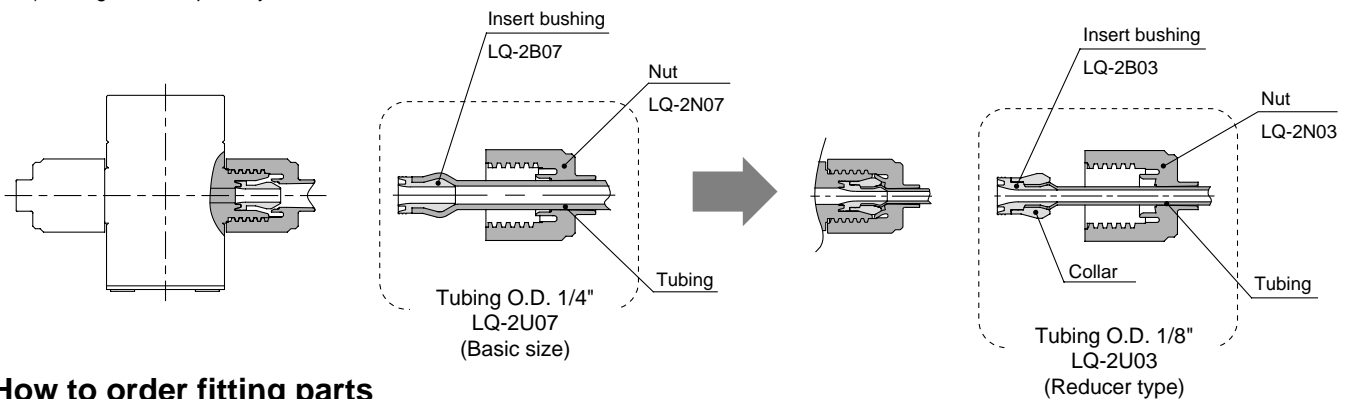

#### How to order fitting parts

**LQ-2U03**

\* Type U is recommended when changing the tubing size.

Symbol	Body class	Applicable model		
		SRF10	SRF30	SRF50
2	2	●		
3	3		●	
5	5			●

Symbol	Parts
U	Nut & Insert bushing
B	Insert bushing
N	Nut

#### Tubing size

Symbol	Tubing O.D.	Body class	Applicable model		
			SRF10	SRF30	SRF50
03	1/8"	2			
04	ø4		●		
05	3/16"				
06	ø6				
07	1/4"				
08	ø8	3			
10	ø10			●	
11	3/8"				
12	ø12	5			
13	1/2"				
19	3/4", ø19				●

## Special Tools

### How to order fitting jig

**LQ-G J** [ ] - [ ] - [ ]

**Insert pin material**

Nil	Resin
S	Stainless steel (J/K type only)

**Insert pin/Holder type**

Nil	Metric size
N	Inch size

Note 1) Compatible pins and holders are included with all sizes. (in parts case)

**Option (L/M type only)**

Symbol	Option
Nil	None
B	With brackets

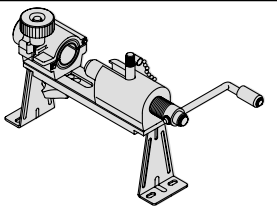

**Type**

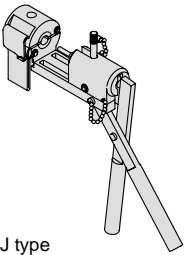
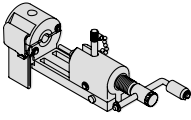
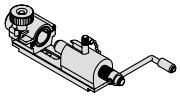
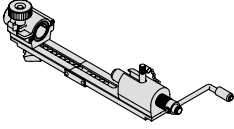
Symbol	Body class	Diagram	
J · K	1, 2		
		J type	K type
L · M	1, 2, 3, 4, 5, 6		
		L type	M type (for short piping)

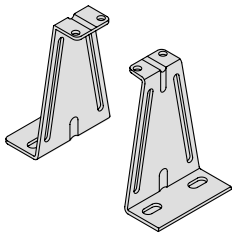

#### Option

	Description	Part no.
Bracket assembly		LQ-GBL

**Table 1 Tubing size symbols**

Type	Body class	Tubing O.D.															
		Metric sizes								Inch sizes							
		ø3	ø4	ø6	ø8	ø10	ø12	ø19	ø25	1/8"	3/16"	1/4"	3/8"	1/2"	3/4"	1"	
J	1	03	04	—	—	—	—	—	—	03	—	—	—	—	—	—	
	2	—	04	06	—	—	—	—	—	03	05	07	—	—	—	—	
L	1	03	04	—	—	—	—	—	—	03	—	—	—	—	—	—	
	2	—	04	06	—	—	—	—	—	03	05	07	—	—	—	—	
	3	—	—	06	08	10	—	—	—	—	—	07	11	—	—	—	
	4	—	—	—	—	10	12	—	—	—	—	—	11	13	—	—	
	5	—	—	—	—	—	12	19	—	—	—	—	—	13	19	—	
	6	—	—	—	—	—	—	19	25	—	—	—	—	—	19	25	

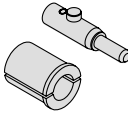
#### Replacement parts

Description	Part No.								
 Insert pin holder assembly (with the parts case)	<b>LQ-GP J</b> [ ] - [ ] Type Insert pin material (J/K type only) <table border="1"> <tr> <td>Nil</td> <td>Resin</td> </tr> <tr> <td>S</td> <td>Stainless steel</td> </tr> </table> Insert pin/Holder type <table border="1"> <tr> <td>Nil</td> <td>Metric sizes</td> </tr> <tr> <td>S</td> <td>Inch sizes</td> </tr> </table>	Nil	Resin	S	Stainless steel	Nil	Metric sizes	S	Inch sizes
Nil	Resin								
S	Stainless steel								
Nil	Metric sizes								
S	Inch sizes								
 Insert pin (single)	<b>LQ-GP 2 J</b> [ ] - [ ] - <b>07</b> Body class (Refer to Table 1) Type Insert pin material (J/K type only) <table border="1"> <tr> <td>Nil</td> <td>Resin</td> </tr> <tr> <td>S</td> <td>Stainless steel</td> </tr> </table> Tubing size symbol (Refer to Table 1)	Nil	Resin	S	Stainless steel				
Nil	Resin								
S	Stainless steel								
 Holder (single)	<b>LQ-GH J</b> - <b>07</b> Type Tubing size symbol (Refer to Table 1)								

Note1) Replacement part type J shows the parts for LQ-GJ and LQ-GK. Replacement part type L shows the parts for LQ-GL and LQ-GM.

**Special Tools**

**Dimensions**

**LQ-GJ**

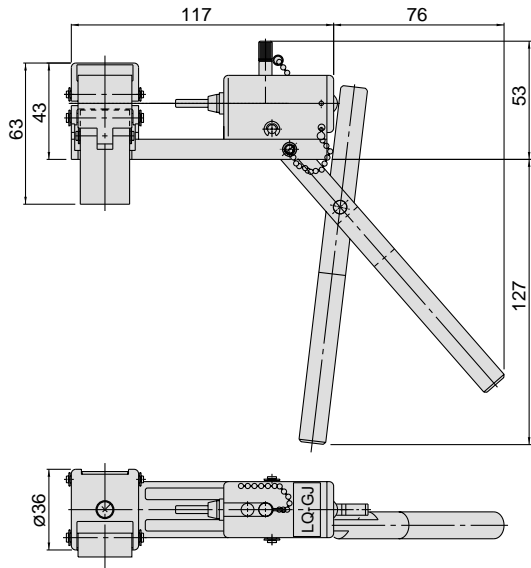

**LQ-GK**

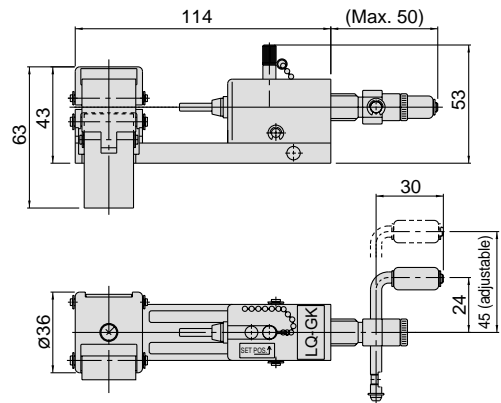

**LQ-GM**

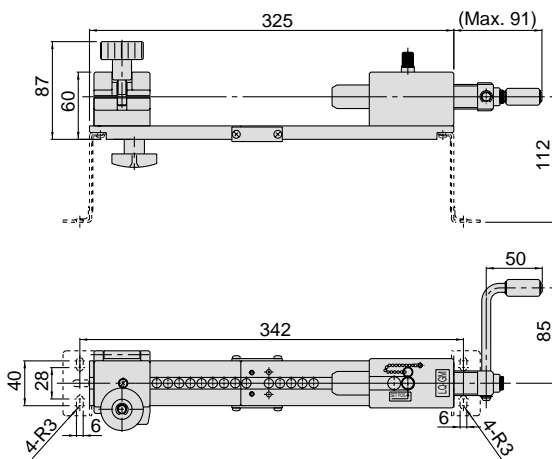

**LQ-GL**

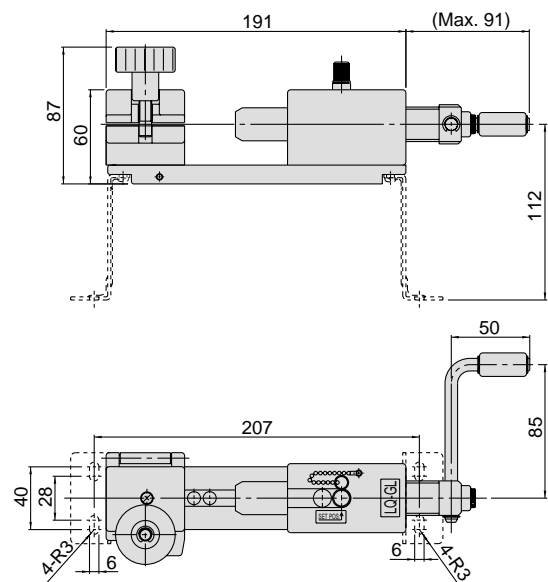

## Fitting Assembly Procedure

Assemble fittings following the procedure shown below.

### J type

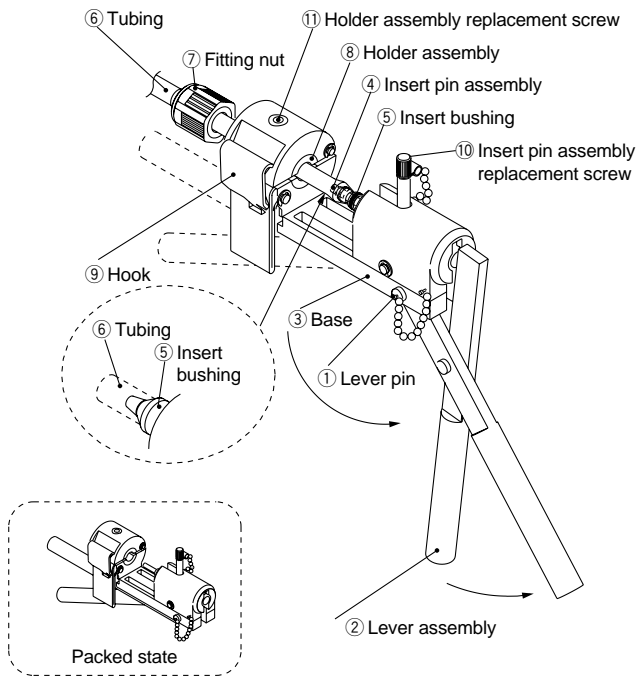

### K type

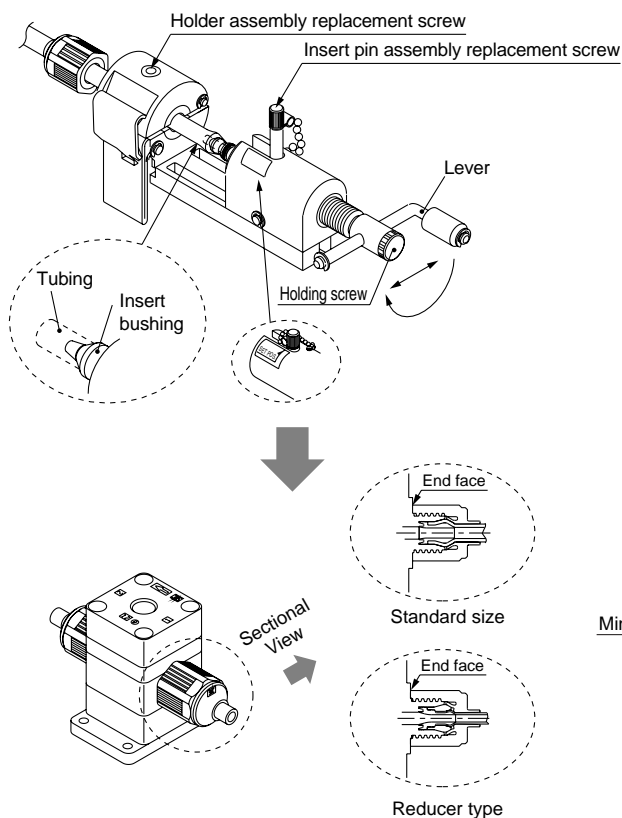

### J type fitting assembly procedure

- 1 Pull out the lever pin ①. Rotate the lever assembly ② to align the holes on the lever assembly ② and the base ③. Insert the lever pin ① into the holes to fix the lever assembly ②.
  - 2 Place the insert bushing ⑤ on the insert pin assembly ④.
  - 3 Cut the end of the tubing ⑥ at a right angle and pass it through the fitting nut ⑦. After placing the tubing ⑥ in the holder assembly ⑧, push it onto the insert bushing ⑤ until it stops and clamp it with the hook ⑨.
- ⚠ Caution**
- When the tubing ⑥ is curved, straighten it out before using it.
  - The tubing ⑥ may slip if there is oil or dust, etc., on the holder assembly ⑧. Remove the contamination using alcohol or another suitable cleaner.
- 4 Press the insert bushing ⑤ into the tubing ⑥ by turning the lever assembly ②.
  - 5 To replace the insert pin assembly ④ and holder assembly ⑧, use the insert pin assembly replacement screw ⑩ and the holder assembly replacement screws ⑪, respectively.

### K type fitting assembly procedure

- For procedure to set and press fit the insert pin assembly, refer to L, M type fitting assembly procedures.
- For procedure to set the tubing, refer to J type procedure.

- 1 } Refer to J type assembly procedure.
- 5 }
- 6 Tighten the fitting nut ⑦ until it reaches the prescribed position on the body (end face). As a guide, refer to the proper tightening torques shown below.

#### Nut tightening torque for piping

Body class	Torque (Nm)	
	LQ1	LQ2
2	0.3 to 0.4	1.5 to 2.0

⚠ Note 1) In case of body class 1, the nut should be tightened manually.

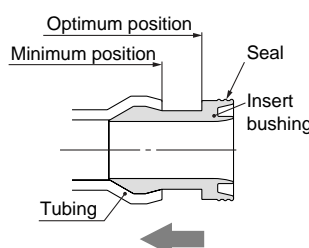

#### ⚠ Precautions on installation

- Be careful not to scratch or dent the seal of the insert bushing. (Refer to the illustration on the left.)
- When the insert bushing inserted, its tubing end should be closer to seal side than the minimum position. (Refer to the illustration on the left.)

## Fitting Assembly Procedure

Assemble fittings following the procedure shown below.

### L type

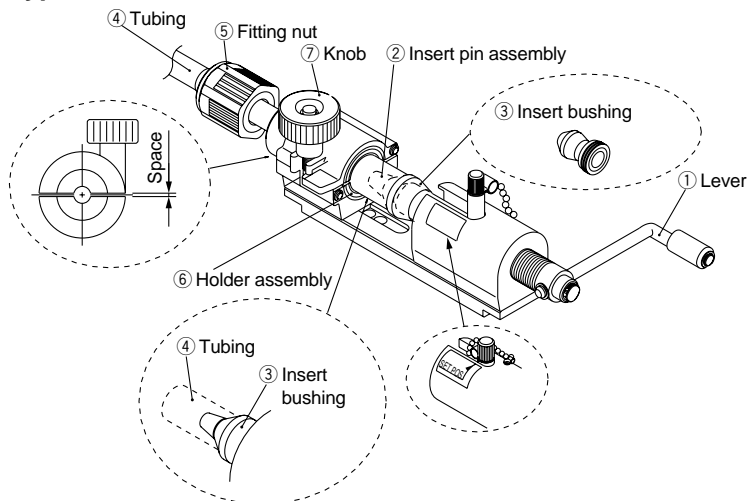

### M type

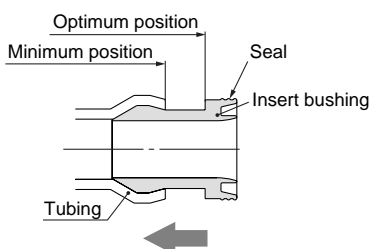
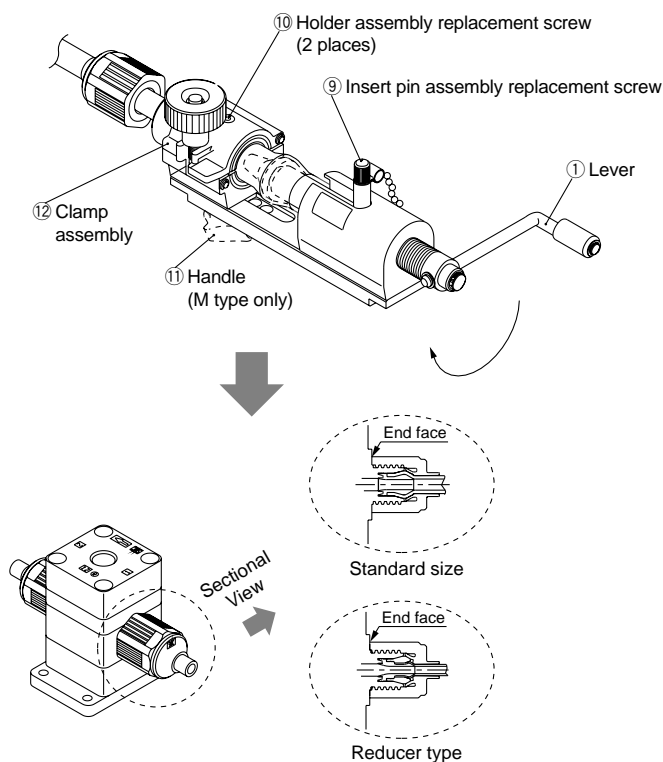

### L/M type fitting assembly procedure

- 1 Turn the lever ① and move to SET POS.
- 2 Place the insert bushing ③ on the insert pin assembly ②.
- 3 Cut the end of the tubing ④ at a right angle and pass it through the fitting nut ⑤. After placing the tubing ④ in the holder assembly ⑥, push it onto the insert bushing ③ until it stops and clamp it with the knob ⑦. When tightening the tubing ④ with the knob ⑦, maintain uniform clearance on both sides of the holder.
- ⚠ Caution**
  - When the tubing ④ is curved, straighten it out before using it.
  - The tubing ④ may slip if there is oil or dust, etc., on the holder assembly ⑥. Remove the contamination using alcohol or another suitable cleaner.
- 4 Press the insert bushing ③ into the tubing ④ by turning the lever ①. (Pressing in can be accomplished with 2 or 3 turns of the lever ①.)
- 5 To replace the insert pin assembly ② and holder assembly ⑥, use the insert pin assembly replacement screw ⑨ and the holder assembly replacement screws ⑩, respectively.
- 6 In case of M type for short piping, remove the handle ⑪, slide the clamp assembly ⑫ to attain the specified length, then secure it again with the handle ⑪.
- 7 Tighten the fitting nut ⑤ to the prescribed position on the body (end face). As a guide, refer to the proper tightening torques shown below.

#### Nut tightening torque for piping

Body class	Torque (Nm)	
	LQ1	LQ2
2	0.3 to 0.4	1.5 to 2.0
3	0.8 to 1.0	3.0 to 3.5
4	1.0 to 1.2	7.5 to 9
5	2.5 to 3.0	11 to 13
6	5.5 to 6.0	—

 Note 1) In case of body class 1, the nut should be tightened manually.

#### ⚠ Precautions on installation

- Be careful not to scratch or dent the seal of the insert bushing. (Refer to the illustration on the left.)
- When the insert bushing inserted, its tubing end should be closer to seal side than the minimum position. (Refer to the illustration on the left.)



# Applicable Fluids

## The wetted part material and fluid compatibility check list

Fluid	Compatibility	
	PFA (Body)	PTFE (Diaphragm)
Acetone	<input type="radio"/> Note 1)	
Ammonium hydroxide	<input type="radio"/>	
Isobutyl alcohol	<input type="radio"/> Note 1)	
Isopropyl alcohol	<input type="radio"/> Note 1)	
Hydrochloric acid	<input type="radio"/>	
Hydrogen peroxide	<input type="radio"/>	
Ethyl acetate	<input type="radio"/> Note 1)	
Butyl acetate	<input type="radio"/> Note 1)	
Nitric acid	<input type="radio"/>	
DI water	<input checked="" type="radio"/>	
Sodium hydroxide	<input type="radio"/>	
Nitrogen gas	<input checked="" type="radio"/>	
Toluene	<input type="radio"/> Note 1)	
Hydrofluoric acid	<input type="radio"/>	
Sulfuric acid	<input type="radio"/>	
Phosphoric acid	<input type="radio"/>	

### Table symbols

- ☉ : The fluid is compatible with the material, and can be used with the products.
- : In some cases even when the fluid is compatible with the material, it may still permeate from the components and effect other materials.



Note 1) Since static electricity may be generated, implement suitable countermeasures.

- The material and fluid compatibility check list provides reference values as a guide only, therefore we do not guarantee the application to our product.
- The data above is based on the information presented by the material manufacturers.
- SMC is not responsible for its accuracy and any damage happened because of this data.



# Series SRF Safety Instructions

These safety instructions are intended to prevent a hazardous situation and/or equipment damage. These instructions indicate the level of potential hazard by labels of "**Caution**", "**Warning**" or "**Danger**". To ensure safety, be sure to observe ISO 4414 <sup>Note 1)</sup>, JIS B 8370 <sup>Note 2)</sup> and other safety practices.

-  **Caution** : Operator error could result in injury or equipment damage.
-  **Warning** : Operator error could result in serious injury or loss of life.
-  **Danger** : In extreme conditions, there is a possible result of serious injury or loss of life.

Note 1) ISO 4414: Pneumatic fluid power --General rules relating to systems.

Note 2) JIS B 8370 : Pneumatic system axiom.

## Warning

### **1. The compatibility of equipment is the responsibility of the person who designs the system or decides its specifications.**

Since the products specified here are used in various operating conditions, their compatibility for the specific system must be based on specifications or after analysis and/or tests to meet your specific requirements. The expected performance and safety assurance will be the responsibility of the person who has determined the compatibility of the system. This person should continuously review the suitability of all items specified. Referring to the latest catalogue information with a view to giving due consideration to any possibility of equipment failure when configuring a system.

### **2. Only trained personnel should operate machinery and equipment.**

Assembly, handling or maintenance of machinery and equipment should be performed by trained and experienced operators.

### **3. Do not service machinery/equipment or attempt to remove components until safety is confirmed.**

### **4. To promote safe operation, be sure to observe company standards and legal regulations, etc.**

Refer to ISO4414, JIS B 8370 (pneumatic system axiom), labor health and safety laws and other safety regulations.



## Series SRF

# Clean Regulator/Fluoro Resin Type/Precautions 1

Be sure to read before handling.

### Design and Selection

#### Warning

##### 1. Confirm the specifications.

Give careful consideration to operating conditions such as the application, fluid and environment, and use within the operating ranges specified in this catalogue.

##### 2. Fluids

Operate after confirming the compatibility of the product's component materials with fluids, using the check list on page 15. Contact SMC regarding fluids other than those in the check list.

##### 3. Residual pressure relief is not possible when the inlet pressure is released.

In the case of series SRF, when the inlet pressure is released with the condition that the pressure at outlet side is maintained, the residual pressure cannot be released. If it will be necessary to eliminate pressure from the outlet side, a circuit should be provided for residual pressure relief.

#### Caution

##### 1. Pressure increase in the closed circuit.

Series SRF allows 10 cm<sup>3</sup>/nm of valve leakage from inlet side to outlet side. The outlet pressure may increase when used in a closed circuit. When closing the outlet side, use a bypass circuit as an opening circuit.

##### 2. Depends on operating conditions, oscillation (buzz) may occur even when used within the specification range detailed in this catalogue. Consult SMC for details.

### Mounting

#### Caution

##### 1. Open the sealed package inside a clean room.

This product is packed in sealed double packaging in a clean room. It is recommended that the inside packaging is opened in a clean room or in other clean environments.

##### 2. Ensure space for maintenance

Ensure the necessary space for maintenance activities.

##### 3. Flush out the piping.

Connect these products to piping only after it has been flushed and cleaned properly. If debris or scale etc. remains in the piping, this can cause faulty operation or failure.

##### 4. Confirm the mounted orientation of the product.

If mounted backwards, the device will not operate properly.

##### 5. When piping fittings to the pilot port, use fittings with resin thread.

Fittings with metal thread may damage the pilot port.

### Operating Air Supply

#### Warning

##### 1. Use clean air.

Do not use compressed air which includes chemicals, synthetic oils containing organic solvents, salts or corrosive gases, etc., as this can cause damage or malfunction.

#### Caution

##### 1. When adjusting the pilot pressure, the SMC precision regulator Series IR/ARP, is recommended.



## Series **SRF**

# Clean Regulator/Fluoro Resin Type/Precautions 2

Be sure to read before handling.

### Pressure Adjustment

#### **Warning**

1. **Check the inlet, outlet, and pilot pressure indicators while undertaking pressure and flow settings.**

Pressures over the regulated range may cause damage to the internal parts.

#### **Caution**

1. **Without consumption of the outlet side flow, the outlet pressure will not decrease along with the pilot pressure decrease.**

As this product is not fitted with a relief mechanism, without consumption of the outlet side flow, the outlet pressure will not decrease along with the pilot pressure decrease.

2. **Confirm the inlet pressure.**

Set the outlet pressure to no more than 80% of the supply pressure.

3. **When the inlet pressure is fluctuating, take caution to the setting value of the outlet pressure.**

When the setting value of the outlet pressure is over the inlet pressure, the outlet pressure cannot be stabilized.

4. **When adjusting the flow, set a throttle on the outlet side of the product.**

Without a throttle, the stable adjustment of the flow cannot be achieved.

5. **Do not use fluid containing solid matter.**

This will cause faulty operation.

### Maintenance

#### **Warning**

1. **Before removing equipment or compressed air supply/exhaust devices, shut off the air and power supplies, and exhaust compressed air from inside the system. Further, when restarting equipment after remounting or replacement, first confirm safety and then check the equipment for normal operation.**
2. **After using chemicals or solvent, remove any residual chemicals using de-ionized water and air before the next operation.**
3. **Do not disassemble the product. Products which have been disassembled cannot be guaranteed.**

If disassembly is necessary, consult SMC.

**EUROPEAN SUBSIDIARIES:****Austria**

SMC Pneumatik GmbH (Austria).  
Girakstrasse 8, A-2100 Korneuburg  
Phone: +43 2262-62280, Fax: +43 2262-62285  
E-mail: office@smc.at  
http://www.smc.at

**France**

SMC Pneumatik, S.A.  
1, Boulevard de Strasbourg, Parc Gustave Eiffel  
Bussy Saint Georges F-77607 Marne La Vallée Cedex 3  
Phone: +33 (0)1-6476 1000, Fax: +33 (0)1-6476 1010  
E-mail: contact@smc-france.fr  
http://www.smc-france.fr

**Netherlands**

SMC Pneumatics BV  
De Ruyterkade 120, NL-1011 AB Amsterdam  
Phone: +31 (0)20-5318888, Fax: +31 (0)20-5318880  
E-mail: info@smcpneumatics.nl  
http://www.smcneumatics.nl

**Spain**

SMC España, S.A.  
Zuazobidea 14, 01015 Vitoria  
Phone: +34 945-184 100, Fax: +34 945-184 124  
E-mail: post@smc.smces.es  
http://www.smces.es

**Belgium**

SMC Pneumatics N.V./S.A.  
Nijverheidsstraat 20, B-2160 Wommelgem  
Phone: +32 (0)3-355-1464, Fax: +32 (0)3-355-1466  
E-mail: post@smcpneumatics.be  
http://www.smcneumatics.be

**Germany**

SMC Pneumatik GmbH  
Boschring 13-15, D-63329 Egelsbach  
Phone: +49 (0)6103-4020, Fax: +49 (0)6103-402139  
E-mail: info@smc-pneumatik.de  
http://www.smc-pneumatik.de

**Norway**

SMC Pneumatics Norway A/S  
Vollsveien 13 C, Granfos Næringspark N-1366 Lysaker  
Tel: +47 67 12 90 20, Fax: +47 67 12 90 21  
E-mail: post@smc-norge.no  
http://www.smc-norge.no

**Sweden**

SMC Pneumatics Sweden AB  
Ekhangsvägen 29-31, S-141 71 Huddinge  
Phone: +46 (0)8-603 12 00, Fax: +46 (0)8-603 12 90  
E-mail: post@smcpneumatics.se  
http://www.smc.nu

**Bulgaria**

SMC Industrial Automation Bulgaria EOOD  
16 Kliment Ohridski Blvd., fl.13 BG-1756 Sofia  
Phone: +359 2 9744492, Fax: +359 2 9744519  
E-mail: office@smc.bg  
http://www.smc.bg

**Greece**

S. Parianosopoulos S.A.  
7, Konstantinoupoleos Street, GR-11855 Athens  
Phone: +30 (0)1-3426076, Fax: +30 (0)1-3455578  
E-mail: parianos@hol.gr  
http://www.smceu.com

**Poland**

SMC Industrial Automation Polska Sp.z.o.o.  
ul. Konstruktorska 11A, PL-02-673 Warszawa,  
Phone: +48 22 548 5085, Fax: +48 22 548 5087  
E-mail: office@smc.pl  
http://www.smc.pl

**Switzerland**

SMC Pneumatik AG  
Dorfstrasse 7, CH-8484 Weisslingen  
Phone: +41 (0)52-396-3131, Fax: +41 (0)52-396-3191  
E-mail: info@smc.ch  
http://www.smc.ch

**Croatia**

SMC Industrijska automatika d.o.o.  
Cromerac 12, 10000 ZAGREB  
Phone: +385 1 377 66 74, Fax: +385 1 377 66 74  
E-mail: office@smc.hr  
http://www.smceu.com

**Hungary**

SMC Hungary Ipari Automatizálási Kft.  
Budafoki út 107-113, H-1117 Budapest  
Phone: +36 1 371 1343, Fax: +36 1 371 1344  
E-mail: office@smc-automation.hu  
http://www.smc-automation.hu

**Portugal**

SMC Sucursal Portugal, S.A.  
Rua de Engº Ferreira Dias 452, 4100-246 Porto  
Phone: +351 22-610-89-22, Fax: +351 22-610-89-36  
E-mail: postpt@smc.smces.es  
http://www.smces.es

**Turkey**

Entek Pnömatik San. ve Tic Ltd. Sti.  
Perpa Tic. Merkezi Kat: 11 No: 1625, TR-80270 Okmeydanı Istanbul  
Phone: +90 (0)212-221-1512, Fax: +90 (0)212-221-1519  
E-mail: smc-entek@entek.com.tr  
http://www.entek.com.tr

**Czech Republic**

SMC Industrial Automation CZ s.r.o.  
Hudcova 78a, CZ-61200 Brno  
Phone: +420 5 414 24611, Fax: +420 5 412 18034  
E-mail: office@smc.cz  
http://www.smc.cz

**Ireland**

SMC Pneumatics (Ireland) Ltd.  
2002 Citywest Business Campus, Naas Road, Saggart, Co. Dublin  
Phone: +353 (0)1-403 9000, Fax: +353 (0)1-464-0500  
E-mail: sales@smcpneumatics.ie  
http://www.smcneumatics.ie

**Romania**

SMC Romania srl  
Str. Frunzei 29, Sector 2, Bucharest  
Phone: +40 213205111, Fax: +40 213261489  
E-mail: smcromania@smcromania.ro  
http://www.smcromania.ro

**UK**

SMC Pneumatics (UK) Ltd  
Vincent Avenue, Crownhill, Milton Keynes, MK8 0AN  
Phone: +44 (0)800 1382930 Fax: +44 (0)1908-555064  
E-mail: sales@smcpneumatics.co.uk  
http://www.smcneumatics.co.uk

**Denmark**

SMC Pneumatik A/S  
Knudsminde 4B, DK-8300 Odder  
Phone: +45 70252900, Fax: +45 70252901  
E-mail: smc@smc-pneumatik.dk  
http://www.smcck.com

**Italy**

SMC Italia S.p.A  
Via Garibaldi 62, I-20061 Carugate, (Milano)  
Phone: +39 (0)2-927211, Fax: +39 (0)2-9271365  
E-mail: mailbox@smcitalia.it  
http://www.smcitalia.it

**Russia**

SMC Pneumatik LLC.  
36/40 Sredny pr. St. Petersburg 199004  
Phone: +812 118 5445, Fax: +812 118 5449  
E-mail: smcfa@peterlink.ru  
http://www.smc-pneumatik.ru

**Estonia**

SMC Pneumatics Estonia OÜ  
Laki 12-101, 106 21 Tallinn  
Phone: +372 (0)6 593540, Fax: +372 (0)6 593541  
E-mail: smc@smcpneumatics.ee  
http://www.smcneumatics.ee

**Latvia**

SMC Pneumatics Latvia SIA  
Smerla 1-705, Rīga LV-1006, Latvia  
Phone: +371 (0)777-94-74, Fax: +371 (0)777-94-75  
E-mail: info@smclv.lv  
http://www.smclv.lv

**Slovakia**

SMC Priemyselna Automatizácia, s.r.o.  
Námestie Martina Benku 10, SK-81107 Bratislava  
Phone: +421 2 444 56725, Fax: +421 2 444 56028  
E-mail: office@smc.sk  
http://www.smc.sk

**Finland**

SMC Pneumatics Finland OY  
PL72, Tiistinniityntie 4, SF-02031 ESPOO  
Phone: +358 207 513513, Fax: +358 207 513595  
E-mail: smcfi@smc.fi  
http://www.smc.fi

**Lithuania**

UAB Ottensten Lietuva  
Savanoriu pr. 180, LT-2600 Vilnius, Lithuania  
Phone/Fax: +370-2651602

**Slovenia**

SMC industrijska Avtomatika d.o.o.  
Grajski trg 15, SLO-8360 Zuzemberk  
Phone: +386 738 85240 Fax: +386 738 85249  
E-mail: office@smc-ind-avtom.si  
http://www.smc-ind-avtom.si

**OTHER SUBSIDIARIES WORLDWIDE:**

ARGENTINA, AUSTRALIA, BOLIVIA, BRASIL, CANADA, CHILE,  
CHINA, HONG KONG, INDIA, INDONESIA, MALAYSIA, MEXICO,  
NEW ZEALAND, PHILIPPINES, SINGAPORE, SOUTH KOREA,  
TAIWAN, THAILAND, USA, VENEZUELA

<http://www.smceu.com>  
<http://www.smcworld.com>

SMC CORPORATION 1-16-4 Shimbashi, Minato-ku, Tokio 105 JAPAN; Phone:03-3502-2740 Fax:03-3508-2480