

For Water

Digital Flow Switch

Series PFW

How to Order



Integrated Display Type

PFW7 20 — [] 03 — 27 [] — []

Flow rate range

04	0.5 to 4 /min
20	2 to 16 /min
40	5 to 40 /min
11	10 to 100 /min

Thread type

Nil	Rc
N	NPT
F	G

Port size

Symbol	Port size	Flow rate (/min)			Applicable models
		4	16	40	
03	3/8	●	●		PFW704, PFW720
04	1/2		●	●	PFW720, PFW740
06	3/4			●	PFW740, PFW711
10	1			●	PFW711

Wiring specification

Nil	3m lead wire with connector
N	Without lead wire

Output specification

27	NPN open collector 2 outputs
67	PNP open collector 2 outputs

Unit specification

Nil	With unit switching function
M	Fixed SI unit ^{Note)}

Note) Fixed units:
Real-time flow rate: /min
Accumulated flow: /

Specifications

Model	PFW704	PFW720	PFW740	PFW711
Measured fluid	Water			
Detection type	Karman vortex			
Flow rate measurement and setting range	0.5 to 4 (setting is 0.6 to 4) /min	2 to 16 /min	5 to 40 /min	10 to 100 /min
Minimum setting unit	0.05 /min	0.1 /min	0.5 /min	1 /min
Display units ^{Note 1)}	Real-time flow rate	/min, gal (US)/min		
	Accumulated flow	/, gal (US)		
Operating pressure range	0 to 1MPa			
Proof pressure	1.5MPa			
Accumulated flow range	0.0 to 99999.9/	0 to 99999 /		
Operating temperature range	0° to 50°C (with no condensation)			
Linearity	±5% F.S. or less			±3% F.S. or less
Repeatability	±3% F.S. or less			±2% F.S. or less
Temperature characteristics	±5% F.S. or less (0° to 50°C)			±3% F.S. or less (15° to 35°C) ±5% F.S. or less (0° to 50°C)
Output specifications ^{Note 2)}	Switch output	NPN open collector	Maximum load current: 80mA; Internal voltage drop: 1V or less (with load current of 80mA) Maximum applied voltage: 30V	
		PNP open collector	Maximum load current: 80mA Internal voltage drop: 1.5V or less (with load current of 80mA)	
Indicator lights	Lights up when output is ON, OUT1: Green; OUT2: Red			
Response time	1 sec. or less			
Hysteresis	Hysteresis mode: Variable (can be set from 0), Window comparator mode: 3-digit fixed ^{Note 3)}			
Power supply voltage	12 to 24VDC (ripple ±10% or less)			
Current consumption	70mA or less			80mA or less
Withstand voltage	1000VAC for 1 min. between external terminal and case			
Insulation resistance	50MΩ (500VDC) between external terminal and case			
Noise resistance	1000Vp-p, Pulse width 1μs, Rise time 1ns			
Vibration resistance	10 to 500Hz at whichever is smaller: 1.5mm amplitude or 98m/s ² acceleration in X, Y, Z directions for 2 hrs. each			
Impact resistance	490m/s ² in X, Y, Z directions 3 times each			
Weight	460g (without lead wire)	520g (without lead wire)	700g (without lead wire)	1,150g (without lead wire)
Enclosure	IP65			
Port size (Rc, NPT, G)	3/8	3/8, 1/2	1/2, 3/4	3/4, 1

Note 1) For digital flow switch with unit switching function. (Fixed SI unit [/min or /] will be set for switch type without the unit switching function.)

Note 2) The output functions operate only for the real-time flow rate display, and do not operate for the accumulated flow display.

Note 3) Window comparator mode — Since hysteresis will reach 3 digits, keep P1 and P2 apart by 7 digits or more. The minimum setting unit is 1digit. (refer to the table above).

How to Order



Remote Type Display Unit

PFW3 0 0 - A -

● **Flow rate range**

1	0.5 to 4 /min
0	2 to 16 /min
2	5 to 40 /min
3	10 to 100 /min

● **Output specification**

0	NPN open collector 2 outputs
1	PNP open collector 2 outputs

● **Mounting**

A	Panel mounting
B	DIN rail, wall mounting

DIN rail type for PFW330-B (for 100 /min) is a semi-standard option.

● **Panel mount adapter part no.**

Description	Panel adapter B
Part No.	ZS-22-02

● **Unit specification**

Nil	With unit switching function
M	Fixed SI unit ^{Note)}

Note) Fixed units:
Real-time flow rate: /min
Accumulated flow: /

Specifications

Model	PFW310	PFW311	PFW300	PFW301	PFW320	PFW321	PFW330	PFW331
Flow rate measurement and set flow rate range	0.5 to 4 (setting is 0.6 to 4) /min		2 to 16 /min		5 to 40 /min		10 to 100 /min	
Minimum setting unit	0.05 /min		0.1 /min		0.5 /min		1 /min	
^{Note 1)} Display units	Real-time flow rate	/min, gal (US)/min						
	Accumulated flow	/ gal (US)						
Accumulated flow range	0.0 to 99999.9 /			0 to 999999 /				
Operating temperature range	0° to 50°C (with no condensation)							
Linearity ^{Note 2)}	±5% F.S. or less						±3% F.S. or less	
Repeatability ^{Note 2)}	±3% F.S. or less						±1% F.S. or less	
Temperature characteristics ^{Note 2)}	±5% F.S. or less (0° to 50°C)						±1% F.S. or less (15° to 35°C) ±2% F.S. or less (0° to 50°C)	
Output specifications ^{Note 3)}	Switch output	NPN open collector		Maximum load current: 80mA Maximum applied voltage: 30V Internal voltage drop: 1V or less (with load current of 80mA)				
		PNP open collector		Maximum load current: 80mA Internal voltage drop: 1.5V or less (with load current of 80mA)				
Indicator lights	Lights up when output is ON, OUT1: Green; OUT2: Red							
Response time	1 sec. or less							
Hysteresis	Hysteresis mode: Variable (can be set from 0) Window comparator mode: 3-digit fixed ^{Note 4)}							
Power supply voltage	12 to 24VDC (ripple ±10% or less)							
Current consumption	50mA or less						60mA or less	
Weight	45g							
Enclosure	IP40							

Note 1) For digital flow switch with unit switching function. (Fixed SI unit [/min or /] will be set for switch types without the unit switching function.)

Note 2) The system accuracy when combined with PFW5□□□.

Note 3) The output functions operate only for the real-time flow rate display, and do not operate for the accumulated flow display.

Note 4) Window comparator mode — Since hysteresis will reach 3 digits, keep P1 and P2 apart by 7 digits or more. The minimum setting unit is 1 digit. (refer to the table above).

How to Order



Remote Type Sensor Unit **PFW5** **20** — **03** □ □ □

● **Flow rate range**

04	0.5 to 4 /min
20	2 to 16 /min
40	5 to 40 /min
11	10 to 100 /min

● **Thread type**

Nil	Rc
N	NPT
F	G

● **Output specification**

Nil	Pulse output (sensor output) only
1	Pulse output + 1 to 5V
2	Pulse output + 4 to 20mA

● **Wiring specification**

Nil	Lead wire with connector
N	Without lead wire

● **Port size**

Symbol	Port size	Flow rate (/min)				Applicable models
		4	16	40	100	
03	3/8	●	●			PFW504, PFW520
04	1/2		●	●		PFW520, PFW540
06	3/4			●	●	PFW540, PFW511
10	1				●	PFW511

Specifications

Model	PFW504	PFW520	PFW540	PFW511
Measured fluid	Water			
Detection type	Karman vortex			
Flow rate measurement range	0.5 to 4 /min	2 to 16 /min	5 to 40 /min	10 to 100 /min
Operating pressure range	0 to 1MPa			
Withstand pressure	1.5MPa			
Operating temperature range	0° to 50°C (with no condensation)			
Linearity ^{Note 1)}	±5% F.S. or less			±3% F.S. or less
Repeatability	±2% F.S. or less			±1% F.S. or less
Temperature characteristics	±5% F.S. or less (0° to 50°C)			±2% F.S. or less (15° to 35°C) ±3% F.S. or less (0° to 50°C)
Power supply voltage	12 to 24VDC (ripple ±10% or less)			
Current consumption	20mA or less			
Weight ^{Note 2)}	410g (without lead wire)	470g (without lead wire)	650g (without lead wire)	1,100g (without lead wire)
Enclosure	IP65			
Port size (Rc, NPT, G)	3/8	3/8, 1/2	1/2, 3/4	3/4, 1
Analog output specifications	Voltage output	Output voltage: 1 to 5V; Load impedance: 100kΩ or more		
	Current output	Current output: 4 to 20mA; Load impedance: 300Ω or less		

Note 1) The system accuracy when combined with PFW3□□.

Note 2) Sensor unit with analog output (PFW5□□-□□-1, -2) is 20g heavier.

Flow Characteristics (Pressure Loss)

PFW704, PFW504

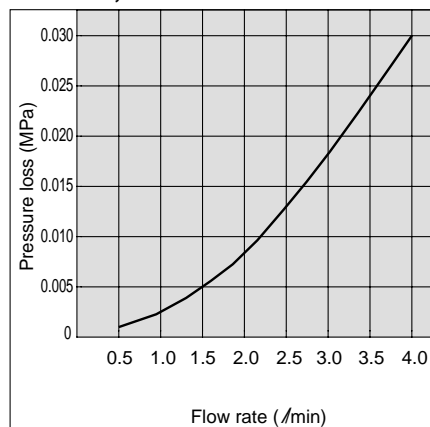

PFW720, PFW520

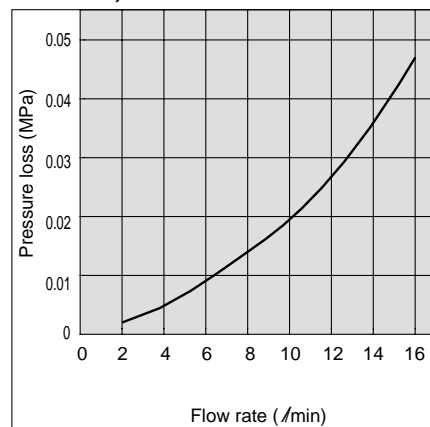

PFW740, PFW540

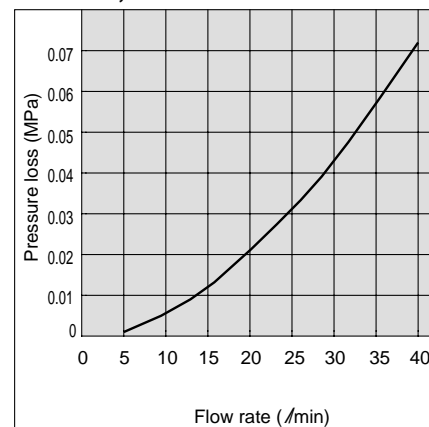

PFW711, PFW511

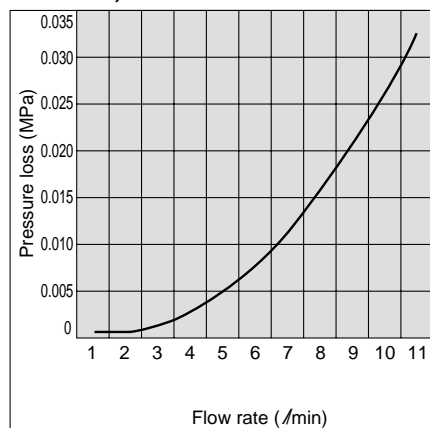

Sensor Unit Construction

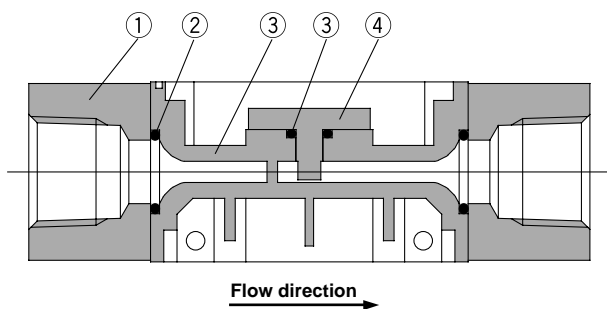

Parts list

No.	Description	Material
1	Attachment	Class 303 stainless steel ^{Note)}
2	Seal	NBR
3	Body	PPS
4	Sensor	PPS

Note) Attachment material for PFW711 and PFW511 is class 304 stainless steel.



Error correction, connectors, operating part descriptions, and flow rate setting are the same as series PFA for air. Refer to pages 1 through 7.

Series PFW

Dimensions: Integrated Display Type for Water

PFW704, PFW720

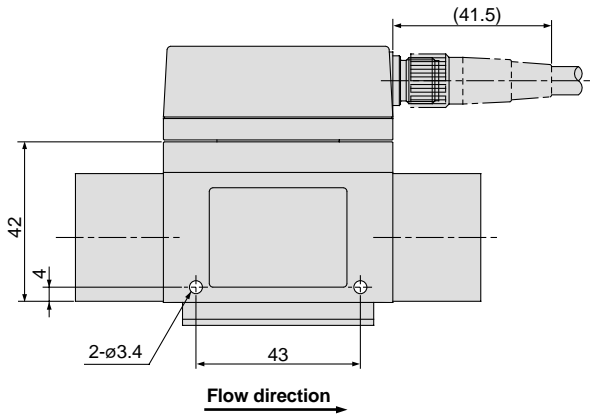
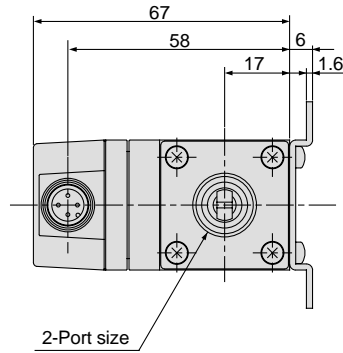
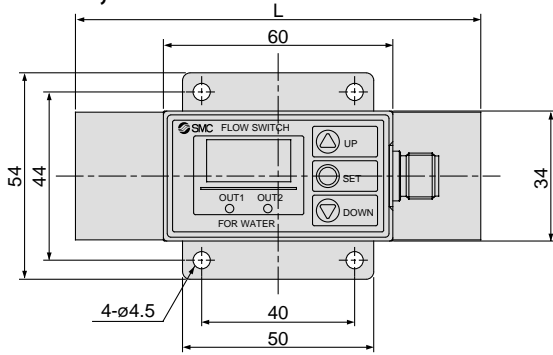

Model	L Dimension
PFW704	100
PFW720	106

Internal circuits and wiring examples

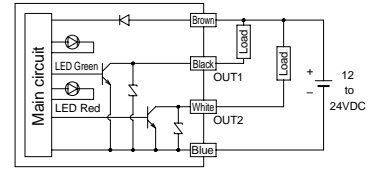

PFW7□□-□□-27□(-M)

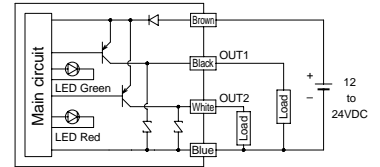

PFW7□□-□□-67□(-M)

Connector pin numbers

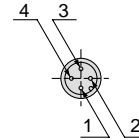

Pin no.	Pin description
1	DC(+)
2	OUT2
3	DC(-)
4	OUT1

PFW740

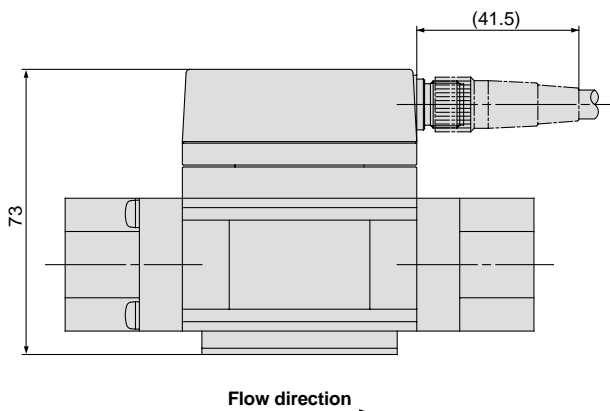
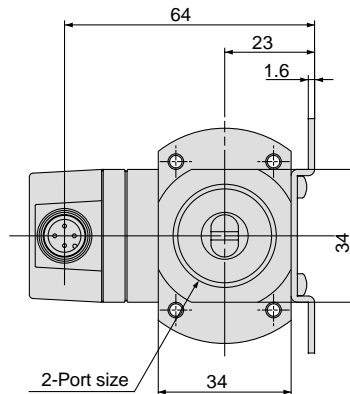
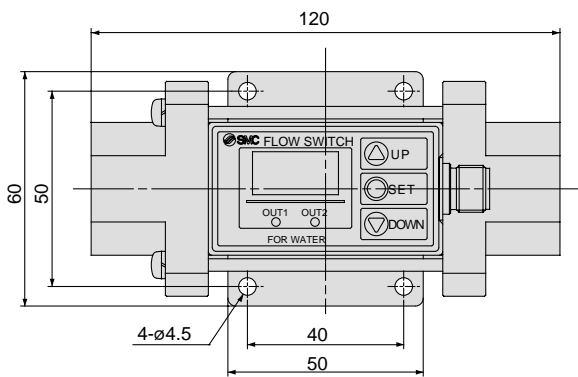

Dimensions: Integrated Display Type for Water

PFW711

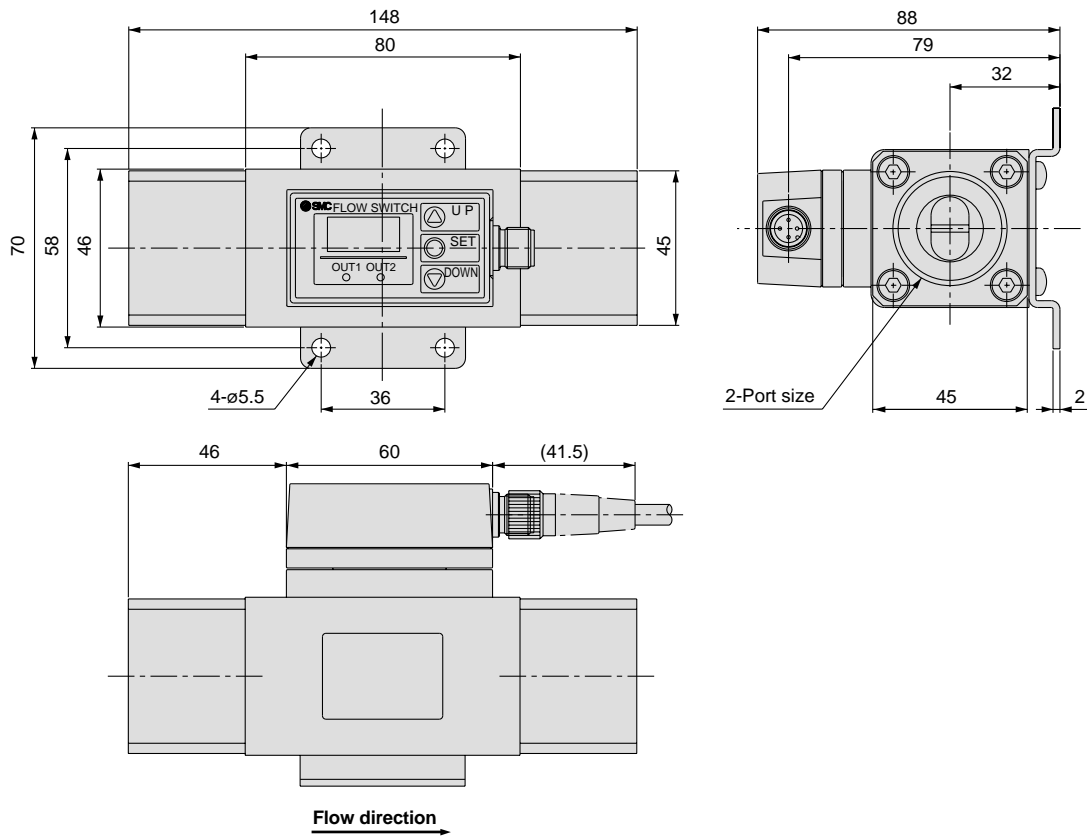

Series PFW

Dimensions: Remote Type Sensor Unit for Water

PFW504, PFW520-□(N)

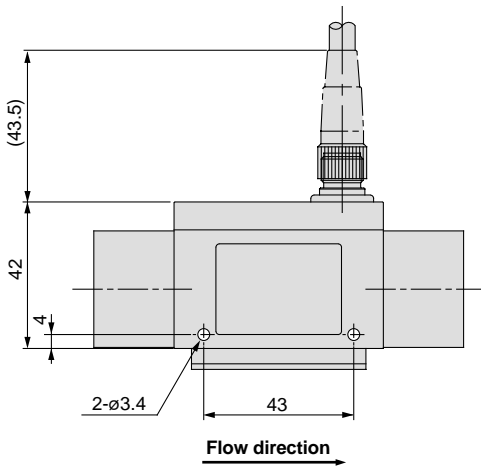
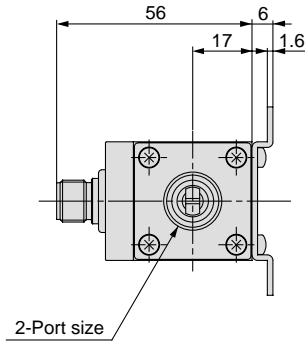
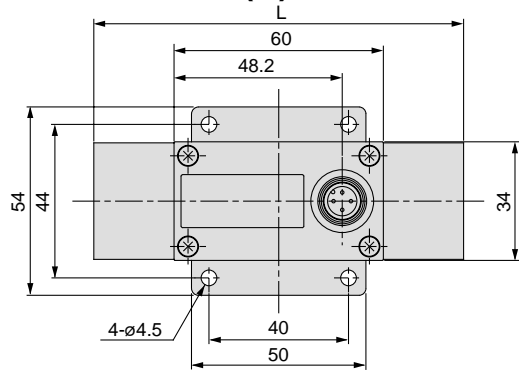

Model	L dimension
PFW504	100
PFW520	106

Wiring

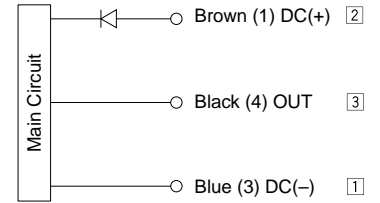

* Use this sensor by connecting to SMC remote type display unit Series PFW3□□.

(1), (3), and (4) are connector pin numbers.

[1], [2], [3] and [4] are terminal numbers for Series PFW3□□.

Connector pin numbers

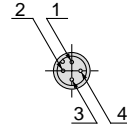

Pin no.	Pin description
1	DC(+)
2	NC
3	DC(-)
4	OUT

PFW540-□(N)

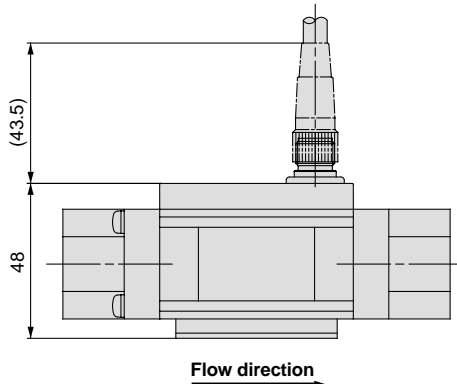
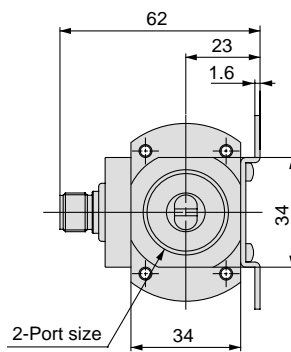
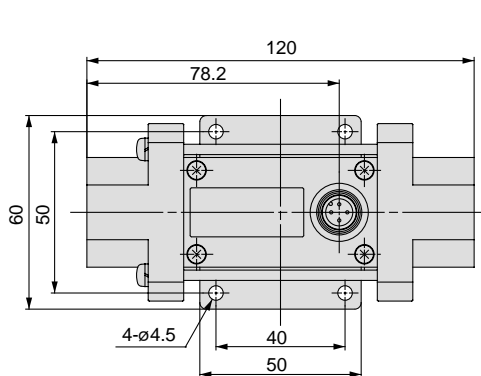

Dimensions: Remote Type Sensor Unit for Water

PFW511-□(N)

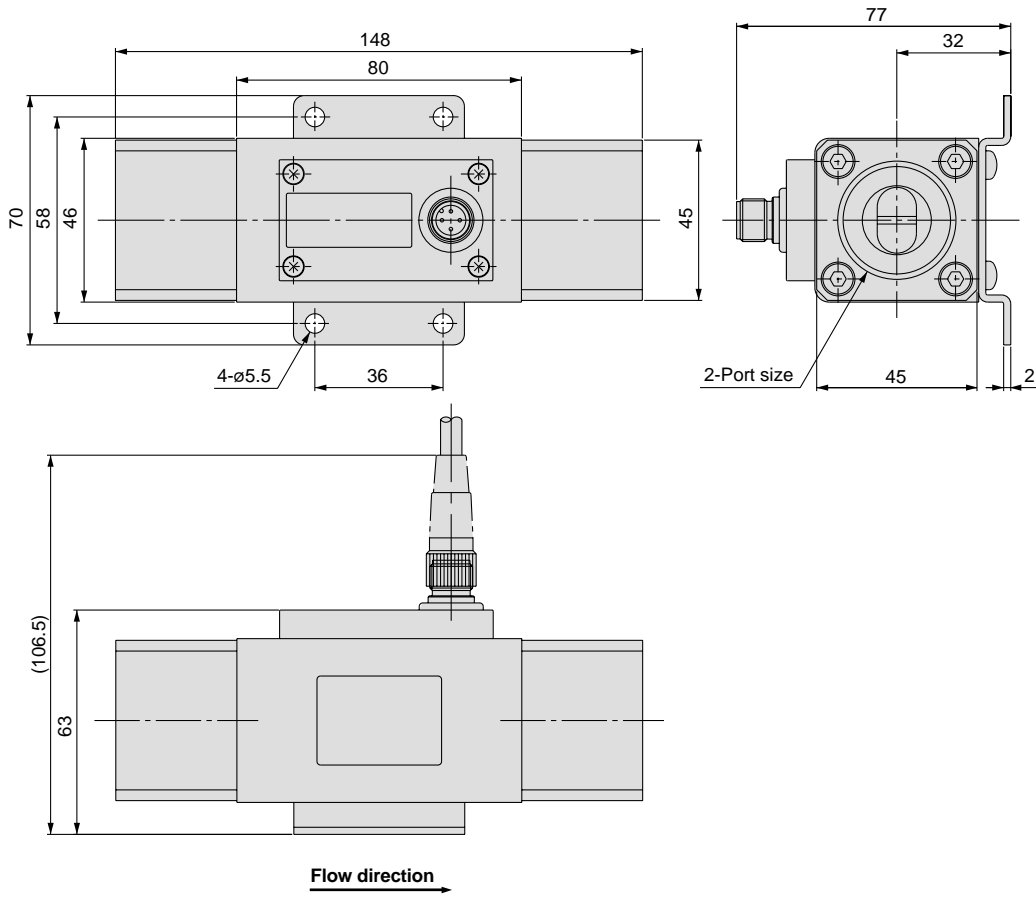

Series PFW

Dimensions: Remote Type Sensor Unit for Water

PFW504, PFW520-□(N)- $\frac{1}{2}$: Analog output

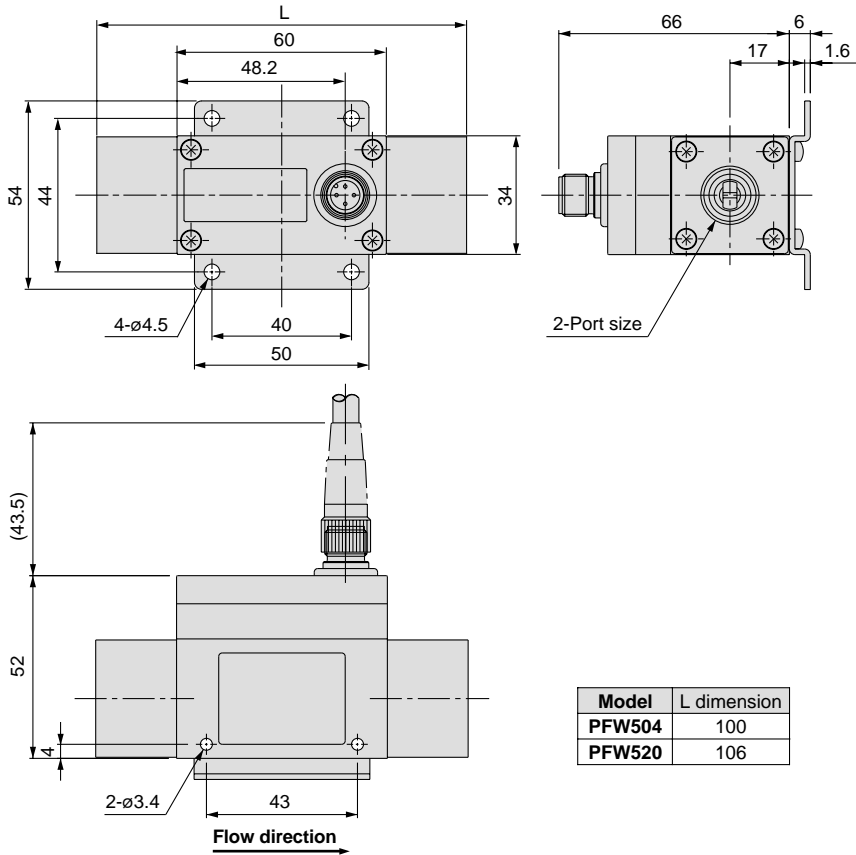

Wiring

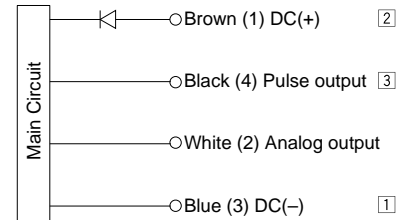

* Use this sensor by connecting to SMC remote type display unit Series PFW3□□.
 (1), (2), (3), and (4) are connector pin numbers.
 ①, ②, and ③ are terminal numbers for Series PFW3□□.

Connector pin numbers

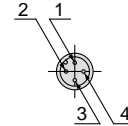

Pin no.	Pin description
1	DC(+)
2	Analog output
3	DC(-)
4	OUT

PFW540-□(N)- $\frac{1}{2}$: Analog output

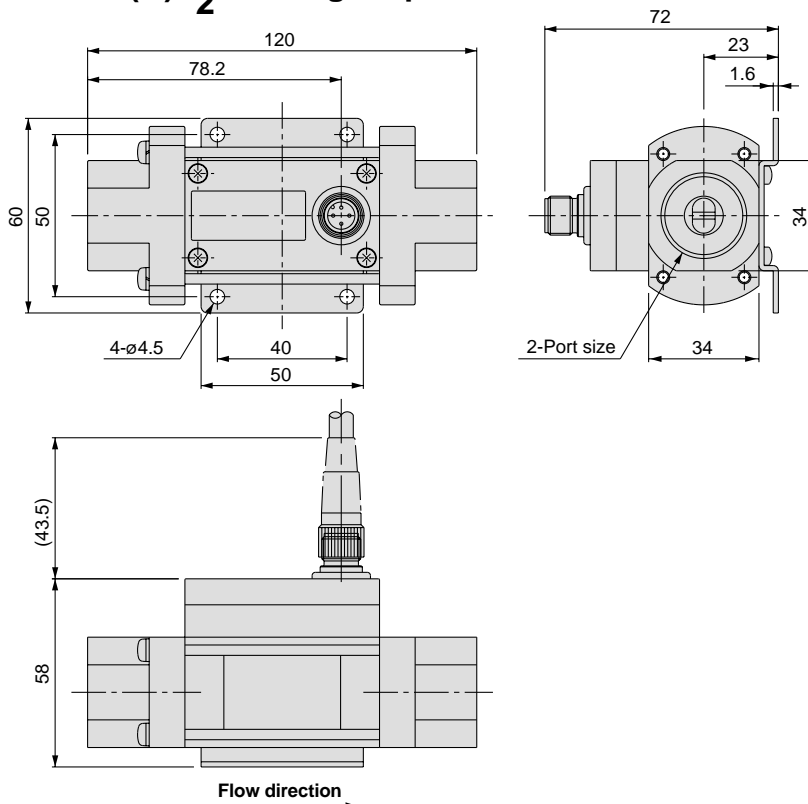

Dimensions: Remote Type Sensor Unit for Water

PFW511-□(N)- $\frac{1}{2}$: Analog output

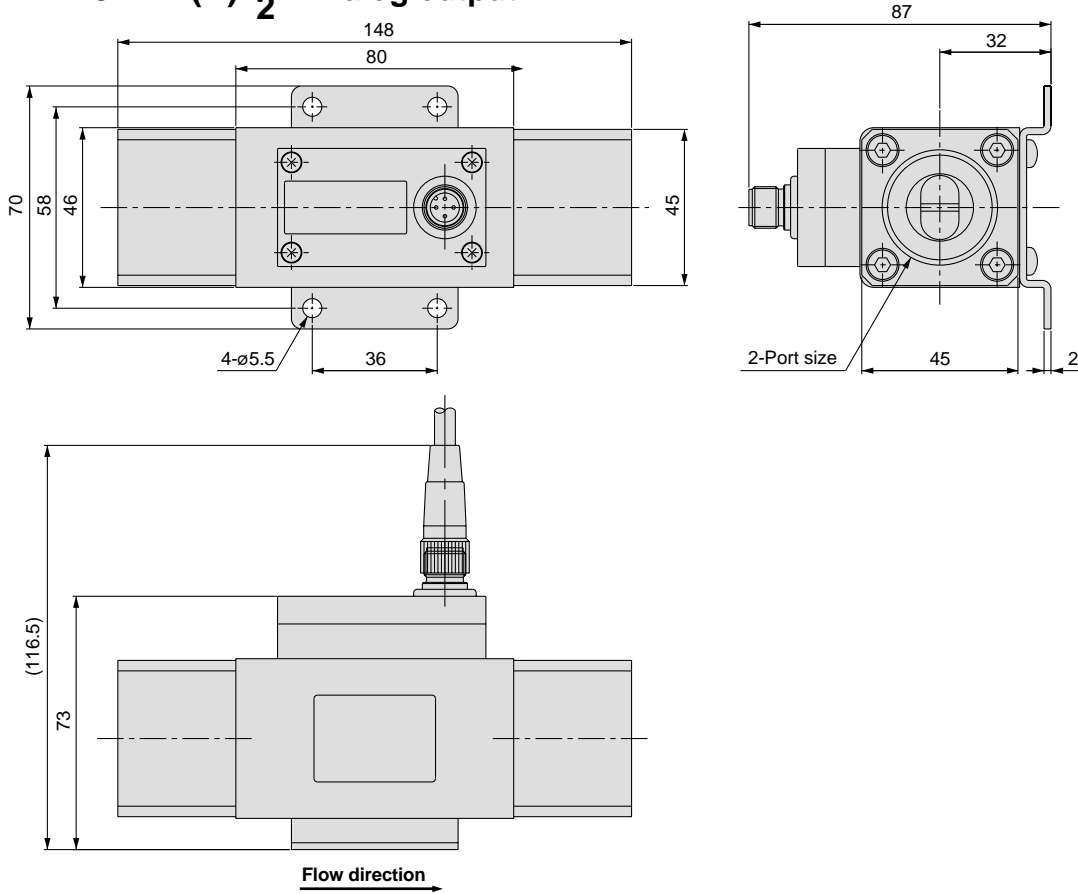

**Analog output
1 to 5VDC**

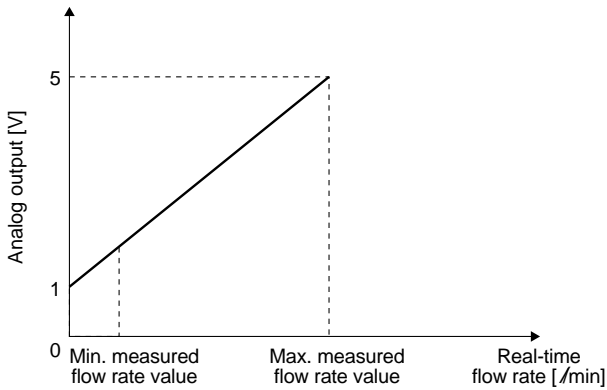

Part no.	Minimum measured flow rate value [L/min]	Maximum measured flow rate value [L/min]
PFW504-□-1	0.5	4
PFW520-□-1	2	16
PFW540-□-1	5	40
PFW511-□-1	10	100

4 to 20mADC

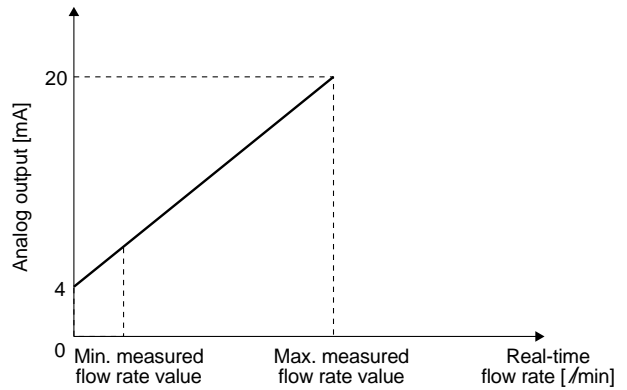

Part no.	Minimum measured flow rate value [L/min]	Maximum measured flow rate value [L/min]
PFW504-□-2	0.5	4
PFW520-□-2	2	16
PFW540-□-2	5	40
PFW511-□-2	10	100

Series PFW

Dimensions: Remote Type Display Unit for Water

PFW3□□-A

Panel mounting type

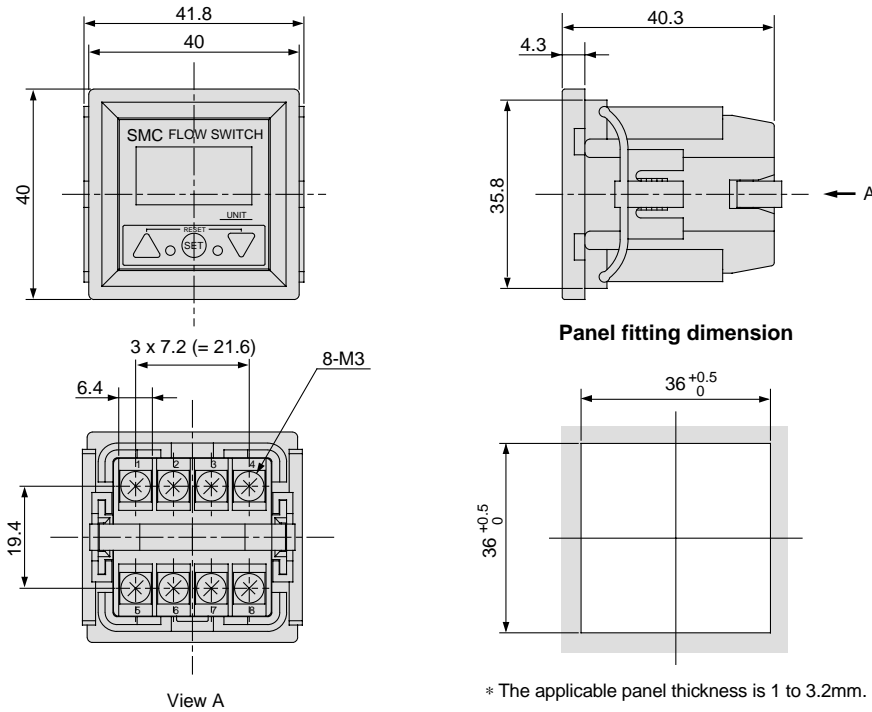

Internal circuits and wiring examples

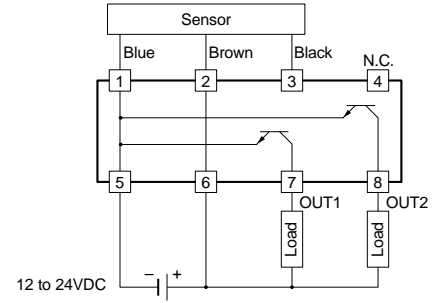

PFW3□0-□(-M)

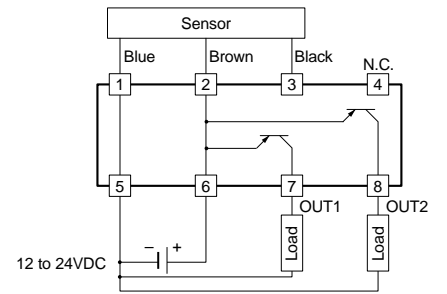

PFW3□1-□(-M)

PFW3□□-B

DIN rail type

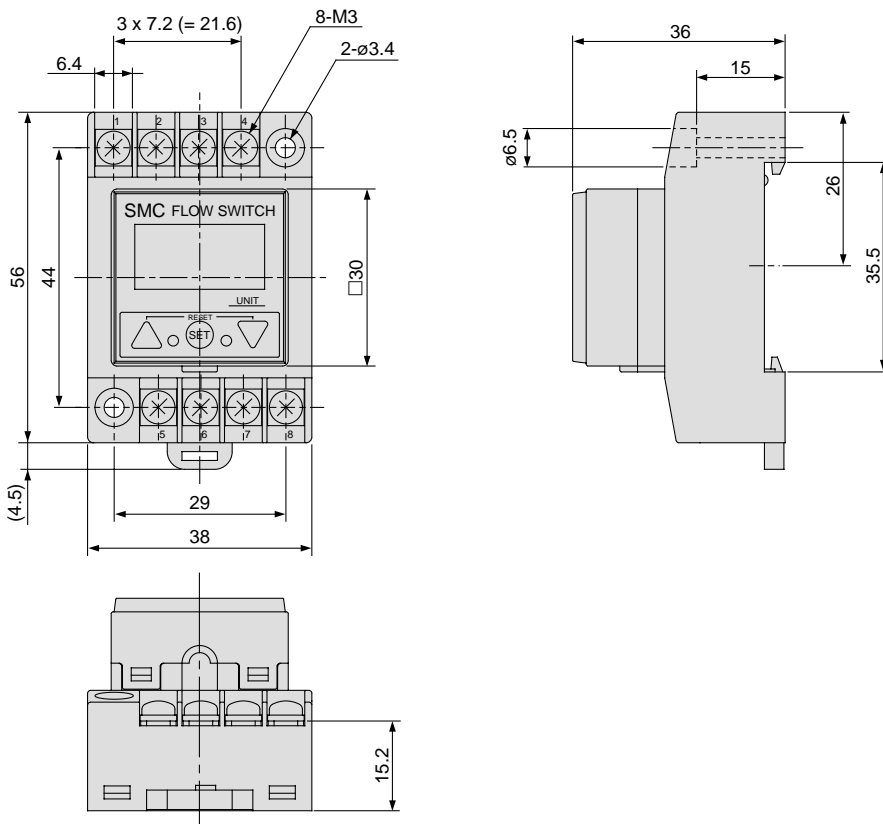

For Water

Digital Flow Switch/High Temperature Fluid Type

Series PFW



How to Order

Integrated Display Type PFW7 20 T — 03 — 27 — —

Flow rate range

04	0.5 to 4 /min
20	2 to 16 /min
40	5 to 40 /min

Temperature range

T	0° to 90°C
---	------------

Thread type

Nil	Rc
N	NPT
F	G

Port size

Symbol	Port size	Flow rate (/min)			Applicable models
		4	16	40	
03	3/8	●	●		PFW704T, PFW720T
04	1/2	●	●	●	PFW720T, PFW740T
06	3/4			●	PFW740T

Unit specification

Nil	With unit switching function
M	Fixed SI unit (Note)

Note) Fixed units:
Real-time flow rate: /min
Accumulated flow: /

Wiring specification

Nil	3m lead wire with connector
N	Without lead wire

Output specification

27	NPN open collector 2 outputs
67	PNP open collector 2 outputs

Specifications

Model	PFW704T	PFW720T	PFW740T
Measured fluid	Water		
Detection type	Karman vortex		
Flow rate measurement and setting range	0.5 to 4 (setting is 0.6 to 4) /min	2 to 16 /min	5 to 40 /min
Minimum setting unit	0.05 /min	0.1 /min	0.5 /min
Display units ^{Note 1)}	Real-time flow rate	/min, gal (US)/min	
	Accumulated flow	/, gal (US)	
Operating pressure range	0 to 1MPa		
Withstand pressure	1.5MPa		
Accumulated flow range	0 to 999999 /		
Operating Temperature range	Fluid temperature	0° to 90°C (with no cavitation)	
	Ambient temperature	0° to 50°C (with no condensation)	
Linearity	±5% F.S. or less		
Repeatability	±3% F.S. or less		
Temperature characteristics	±5% F.S. or less		
Output specifications ^{Note 2)}	Switch output	NPN open collector	Maximum load current: 80mA; Internal voltage drop: 1V or less (with load current of 80mA) Maximum applied voltage: 30V
		PNP open collector	Maximum load current: 80mA Internal voltage drop: 1.5V or less (with load current of 80mA)
Indication lights	Lights up when output is ON OUT1: Green; OUT2: Red		
Response time	1 sec. or less		
Hysteresis	Hysteresis mode: Variable (can be set from 0); Window comparator mode: 3-digit fixed ^{Note 3)}		
Power supply voltage	12 to 24VDC (ripple ±10% or less)		
Current consumption	70mA or less		
Withstand voltage	1000VAC for 1 min. between external terminal and case		
Insulation resistance	50MΩ (500VDC) between external terminal and case		
Noise resistance	1000Vp-p, Pulse width 1μs, Rise time 1ns		
Vibration resistance	10 to 500Hz at whichever is smaller: 1.5mm amplitude or 98m/s ² acceleration, in X, Y, Z directions for 2 hrs. each		
Impact resistance	490m/s ² in X, Y, Z directions 3 times each		
Weight	710g (without lead wire)		
Enclosure	IP65		
Port size (Rc, NPT, G)	3/8	3/8, 1/2	1/2, 3/4

Note 1) For digital flow switch with unit switching function. (Fixed SI unit [/min or /] will be set for switch type without the unit switching function.)

Note 2) The output functions operate only for the real-time flow rate display, and do not operate for the accumulated flow display.

Note 3) Window comparator mode — Since hysteresis will reach 3 digits, keep P1 and P2 apart by 7 digits or more. The minimum setting unit is 1 digit. (refer to the table above).

How to Order

Remote Type
Display Unit

PFW5 **20** T — **03** —

● Flow rate range

04	0.5 to 4 /min
20	2 to 16 /min
40	5 to 40 /min

● Temperature range

T	0° to 90°C
---	------------

● Thread type

Nil	Rc
N	NPT
F	G

● Output specification

Nil	Pulse output (Sensor output) only
1	Pulse output + 1 to 5V
2	Pulse output + 4 to 20mA

● Wiring specification

Nil	3m lead wire with connector
N	Without lead wire

● Port size

Symbol	Port size	Flow rate (/min)			Applicable models
		4	16	40	
03	3/8	●	●		PFW504T, PFW520T
04	1/2		●	●	PFW520T, PFW540T
06	3/4			●	PFW540T



Specifications

Model		PFW504T	PFW520T	PFW540T
Measured fluid		Water		
Detection type		Karman vortex		
Flow rate measurement range		0.5 to 4 /min	2 to 16 /min	5 to 40 /min
Operating pressure range		0 to 1MPa		
Proof pressure		1.5MPa		
Operating Temperature range	Fluid temperature	0° to 90°C (with no cavitation)		
	Ambient temperature	0° to 50°C (with no condensation)		
Linearity ^{Note 1)}		±5% F.S. or less		
Repeatability		±2% F.S. or less		
Temperature characteristics		±5% F.S. or less		
Power supply voltage		12 to 24VDC (ripple ±10% or less)		
Current consumption		20mA or less		
Weight ^{Note 2)}		660g (without lead wire)		
Enclosure		IP65		
Port size (Rc, NPT, G)		3/8	3/8, 1/2	1/2, 3/4
Analog output specifications	Voltage output	Output voltage: 1 to 5V; Load impedance 100kΩ or more		
	Current output	Current output: 4 to 20mA; Load impedance 300Ω or less		

Note 1) The system accuracy when combined with PFW3□□.

Note 2) Sensor unit with analog output (PFW5□□-□□-1, -2) is 20g heavier.



Display units are the same as those of remote type digital flow switch for water (series PFW3□□). Refer to page 21 for details.

Dimensions: Integrated Display Type for Water

PFW704T, PFW720T, PFW740T

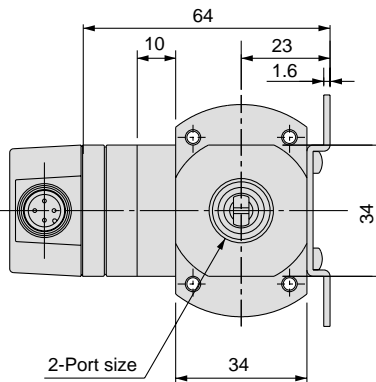
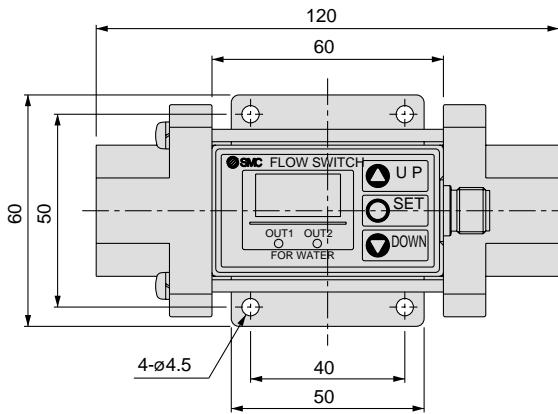

Internal circuits and wiring examples

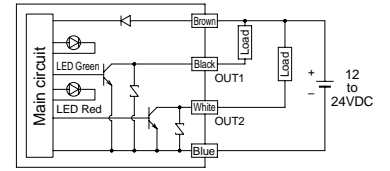

PFW704T-□□-27□(-M)

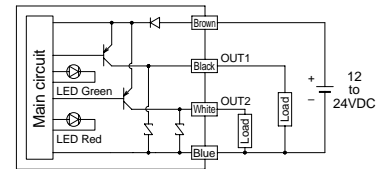

PFW720T-□□-67□(-M)

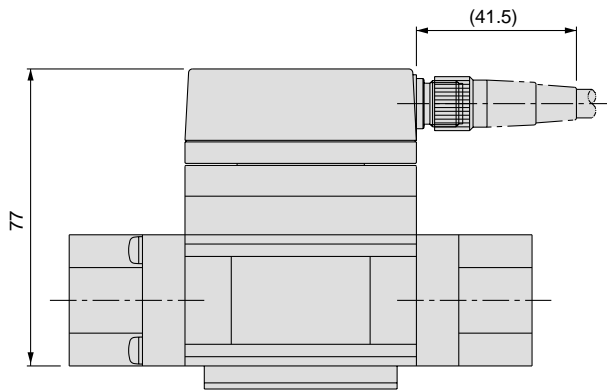

Flow direction →

Connector pin numbers

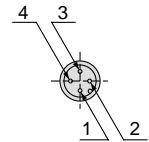

Pin no.	Pin description
1	DC(+)
2	OUT2
3	DC(-)
4	OUT1

Series PFW

Dimensions: Remote Type Sensor Unit for Water

PFW504T, PFW520T, PFW540T-□(N)

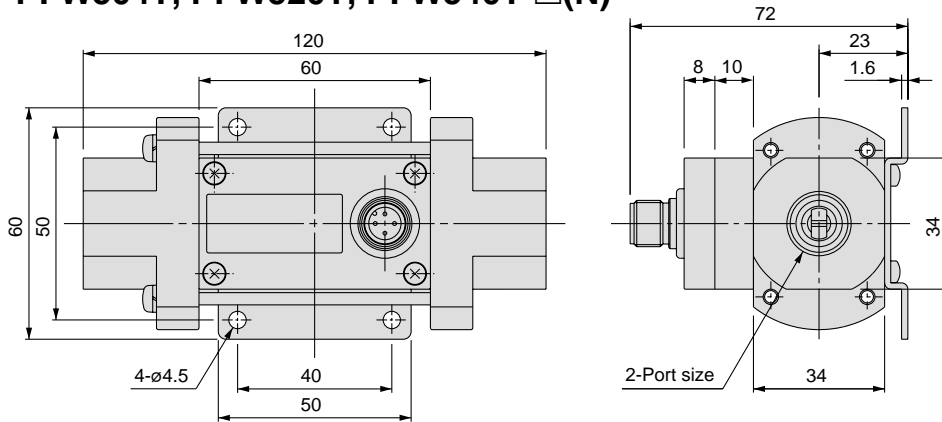

Wiring

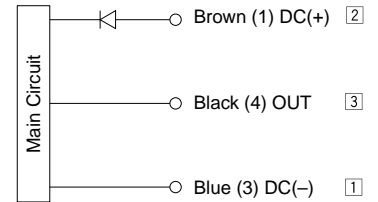

* Use this sensor by connecting to SMC remote type display unit Series PFW3□□.

(1), (3), and (4) are connector pin numbers.

①, ②, and ③ are terminal numbers for Series PFW3□□.

Connector pin numbers

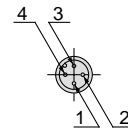

Pin no.	Pin description
1	DC(+)
2	NC
3	DC(-)
4	OUT

PFW504T, PFW520T, PFW540T-□(N)- $\frac{1}{2}$: Analog output

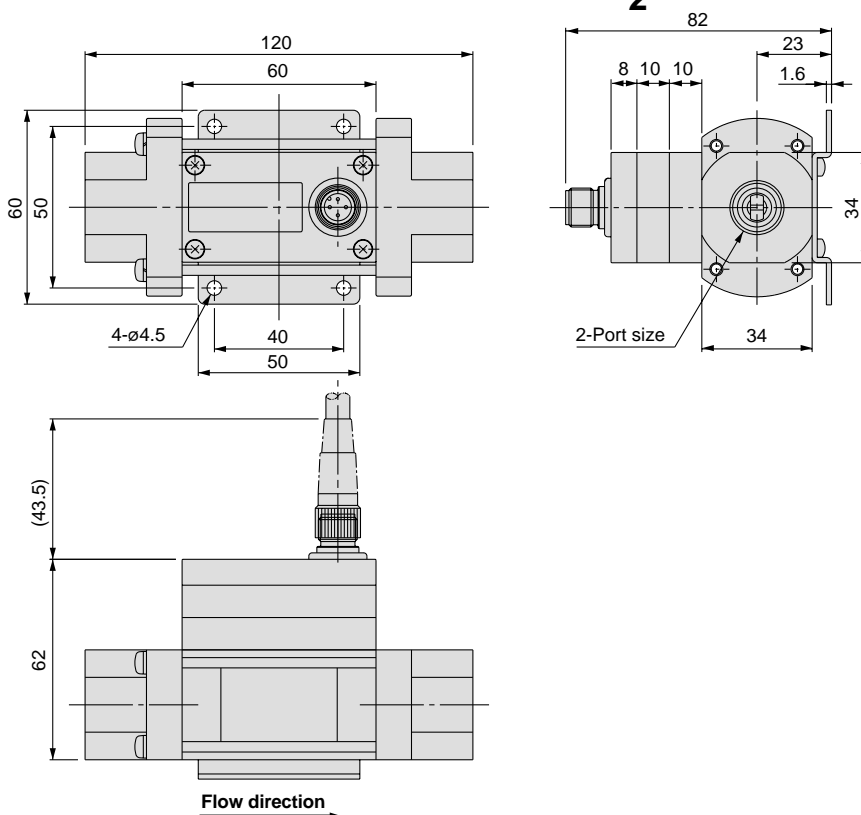

Wiring

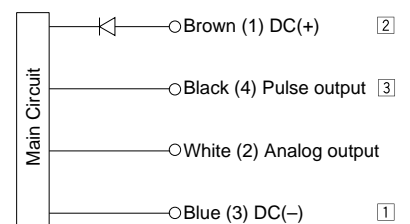

* Use this sensor by connecting to SMC remote type display unit Series PFW3□□.

(1), (2), (3), and (4) are connector pin numbers.

①, ②, and ③ are terminal numbers for Series PFW3□□.

Connector pin numbers

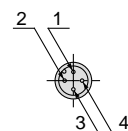

Pin no.	Pin description
1	DC(+)
2	Analog output
3	DC(-)
4	OUT

Remote type Sensor Unit for water

Analog output
1 to 5VDC

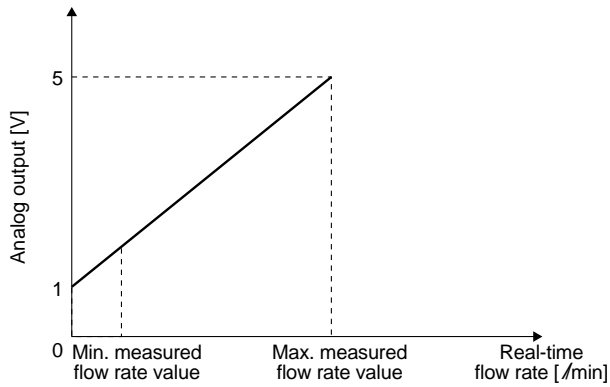

Part no.	Minimum measured flow rate value [l/min]	Maximum measured flow rate value [l/min]
PFW504T-□-1	0.5	4
PFW520T-□-1	2	16
PFW540T-□-1	5	40

4 to 20mADC

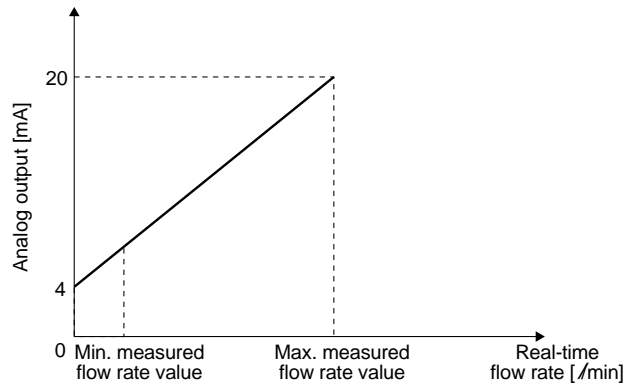

Part no.	Minimum measured flow rate value [l/min]	Maximum measured flow rate value [l/min]
PFW504T-□-2	0.5	4
PFW520T-□-2	2	16
PFW540T-□-2	5	40



Refer to PFW3□□ on page 30 for dimensions of remote type display unit.



Series *PFA/PFW*

Safety Instructions

These safety instructions are intended to prevent a hazardous situation and/or equipment damage. These instructions indicate the level of potential hazard by a label of "**Caution**", "**Warning**", or "**Danger**". To ensure safety, be sure to observe these safety practices.

⚠ Caution : Operator error could result in injury or equipment damage.

⚠ Warning : Operator error could result in serious injury or loss of life.

⚠ Danger : In extreme conditions, there is a possible result of serious injury or loss of life.

⚠ Warning

1. The compatibility of equipment is the responsibility of the person who designs the pneumatic system or decides its specifications.

Since the products specified here are used in various operating conditions, their compatibility with the specific pneumatic system must be based on specifications or after analysis and/or tests to meet your specific requirements.

2. Only trained personnel should operate machinery and equipment.

Equipment can be dangerous if an operator is unfamiliar with it. Assembly, handling or maintenance of systems should be performed by trained and experienced operators.

3. Do not service machinery/equipment or attempt to remove components until safety is confirmed.

1. Inspection and maintenance of machinery/equipment should only be performed after confirmation of safe locked-out control positions.
2. When equipment is to be removed, first confirm that safety measures have been implemented.
3. Before machinery/equipment is restarted, confirm that safety measures have been implemented and proceed with caution.

4. Contact SMC if the product is to be used in any of the following conditions:

1. Conditions and environments beyond the given specifications, or if product is used outdoors.
2. Installation on equipment in conjunction with atomic energy, railway, air navigation, vehicles, medical equipment, food and beverages, recreation equipment, emergency stop circuits, press applications, or safety equipment.
3. An application which has the possibility of having negative effects on people, property, or animals, requiring special safety analysis.



Series PFA/PFW Specific Product Precautions 1

Be sure to read before handling. Refer to page 36 for safety instructions.

Design and Selection

⚠ Warning

1. Operate the switch only within the specified voltage.

Use of the switch outside the range of the specified voltage can cause not only malfunction and damage of the switch but also electrocution and fire.

2. Do not exceed the maximum allowable load specification.

A load exceeding the maximum load specification can cause damage to the switch.

3. Do not use a load that generates surge voltage.

Although surge protection is installed in the circuit at the output side of the switch, damage may still occur if a surge is applied repeatedly. When a surge generating a load such as a relay or solenoid is directly driven, use a type of switch with a built-in surge absorbing element.

4. Since the type of fluid varies depending on the product, be sure to verify the specifications.

The switches do not have an explosion proof rating. To prevent a possible fire hazard, do not use with flammable gases or fluids.

5. Monitor the internal voltage drop of the switch.

When operating below a specified voltage, it is possible that the load may be ineffective even though the pressure switch function is normal. Therefore, the formula below should be satisfied after confirming the minimum operating voltage of the load.

$$\text{Supply voltage} - \text{Internal voltage drop of switch} > \text{Minimum operating voltage of load}$$

[For air]

6. Use the switch within the specified flow rate measurement and operating pressure.

Operating beyond the specified flow rate and operating pressure can damage the switch.

[For water]

7. Use the switch within the specified flow rate measurement and operating pressure.

Operating beyond the specified flow rate and operating pressure can damage the switch. Avoid especially the application of pressure above specifications through a water hammer.

<Examples of pressure reduction measures>

- Use a device such as a water hammer relief valve to slow the valve's closing speed.
- Absorb impact pressure by using an accumulator or elastic piping material such as a rubber hose.
- Keep the piping length as short as possible.

8. Design the system so that the fluid always fills the detection passage.

Especially for vertical mounting, introduce the fluid from the bottom to the top.

9. Operate at a flow rate within the flow rate measurement range.

If operated outside of the flow rate measurement range, the Karman vortex will not be generated and normal measurement will not be possible.

Design and Selection

⚠ Caution

1. Data of the flow switch will be stored even after the power is turned off.

Input data will be stored in EEPROM so that the data will not be lost after the flow switch is turned off. (Data can be rewritten for up to one million times, and data will be stored for up to 20 years.)

Mounting

⚠ Warning

1. Mount switches using the proper tightening torque.

When a switch is tightened beyond the specified tightening torque, the switch may be damaged. On the other hand, tightening below the specified tightening torque may cause the installation screws to come loose during operation.

Thread	Tightening torque N·m	Thread	Tightening torque N·m
Rc 1/8	7 to 9	Rc 3/4	28 to 30
Rc 1/4	12 to 14	Rc 1	36 to 38
Rc 3/8	22 to 24	Rc 1, 1/2	48 to 50
Rc 1/2	28 to 30	Rc 2	48 to 50

2. Apply wrench only to the metal part of the pipings when installing the flow switch onto the system piping.

Do not apply wrench to anything other than the piping attachment as this may damage the switch.

3. Monitor the flow direction of the fluid.

Install and connect piping so that fluid flows in the direction of the arrow indicated on the body.

4. Remove dirt and dust from inside the piping using an air blower before connecting piping to the switch.

5. Do not drop or bump.

Do not drop, bump, or apply excessive impacts (490m/s²) while handling. Although the external body of the switch (switch case) may not be damaged, the inside of the switch could be damaged and cause a malfunction.

6. Hold the body of the switch when handling.

The tensile strength of the cord is 49N. Applying a greater pulling force on it can cause a malfunction. When handling, hold the body of the switch – do not dangle it from the cord.

7. Do not use until you can verify that equipment can operate properly.

Following mounting, repair, or retrofit, verify correct mounting by conducting suitable function and leakage tests after piping and power connections have been made.

8. Avoid the mounting orientation with the bottom of the body facing up.

The switch can be mounted in any way such as vertically or horizontally, however, avoid the mounting orientation with the bracket on the bottom of the body facing upward.

[For air]

9. Never mount a switch in a place that will be used as a scaffold during piping.

Damage may occur if an excessive load is applied to the switch.



Series PFA/PFW Specific Product Precautions 2

Be sure to read before handling. Refer to page 36 for safety instructions.

Mounting

⚠ Warning

10. **Be sure to allow straight pipe length that is minimum 8 times the port size upstream and downstream of the switch piping.**

When abruptly reducing the size of piping or when there is a restriction such as a valve on the upstream side, the pressure distribution in the piping changes and makes accurate measurement impossible. Therefore, flow restriction measures such as these should be implemented on the downstream side of the switch.

[For water]

11. **Never mount a switch in a place that will be used as a scaffold during piping.**

Damage may occur if an excessive load is applied to the switch. Especially when the switch supports the piping, do not apply a load of 15N·m or more to the metal part of the switch.

12. **Be sure to allow straight pipe length that is minimum 8 times the port size upstream and downstream of the switch piping.**

When abruptly reducing the size of piping or when there is a restriction such as a valve on the upstream side, the pressure distribution in the piping changes and makes accurate measurement impossible. Therefore, flow restriction measures such as these should be implemented on the downstream side of the switch.

When used with the downstream side open, be careful of the cavitation that is prone to occur.

Wiring

⚠ Warning

1. **Verify the color and terminal number when wiring.**

Incorrect wiring can cause the switch to be damaged and malfunction. Verify the color and the terminal number in the instruction manual when wiring.

2. **Avoid repeatedly bending or stretching the lead wire.**

Repeatedly applying bending stress or stretching force to the lead wire will cause it to break.

3. **Confirm proper insulation of wiring.**

Make sure that there is no faulty wiring insulation (contact with other circuits, ground fault, improper insulation between terminals, etc.). Damage may occur due to excess current flow into a switch.

4. **Do not wire in conjunction with power lines or high voltage lines.**

Wire separately from power lines and high voltage lines, avoiding wiring in the same conduit with these lines. Control circuits including switches may malfunction due to noise from these other lines.

5. **Do not allow loads to short circuit.**

Although switches indicate excess current error if loads are short circuited, all incorrect wiring connections cannot be protected. Take precautions to avoid incorrect wiring.

Usage

⚠ Warning

1. **When using a switch for high temperature fluid, the switch itself also becomes hot due to the high temperature fluid. Avoid touching the switch directly as this may cause a burn.**

Operating Environment

⚠ Warning

1. **Never use in the presence of explosive gases.**

The switches do not have an explosion proof rating. Never use in the presence of an explosive gas as this may cause a serious explosion.

2. **Mount switches in locations where there is no vibration greater than 98m/s², or greater than 490m/s². Be aware that these are maximum values, so try to keep vibration and impact down to a minimum.**

3. **Do not use in an area where surges are generated.**

When there are units that generate a large amount of surge in the area around pressure switches, (e.g., solenoid type lifters, high frequency induction furnaces, motors, etc.) this may cause deterioration or damage to the switches' internal circuitry. Avoid sources of surge generation and crossed lines.

4. **Switches are not equipped with surge protection against lightning.**

Flow switches are CE compliant; however, they are not equipped with surge protection against lightning. Lightning surge protection measures should be applied directly to system components as necessary.

5. **Avoid using switches in an environment where the likelihood of splashing or spraying of liquids exists.**

Switches are dustproof and splashproof; however, avoid using in an environment where the likelihood of heavy splashing or spraying of liquids exists. Since the display unit of the remote type switches featured here is not dust or splash proof, the use in an environment where liquid splashing or spraying exists must be avoided.

[For air]

6. **Use the switch within the specified fluid and ambient temperature range.**

Fluid and ambient temperatures are 0° to 50°C. Take measures to prevent freezing fluid when below 5°C, since this may cause damage to the switch and lead to a malfunction. The installation of an air dryer is recommended for eliminating condensate and moisture. Never use the switch in an environment where there are drastic temperature changes even when these temperatures are operated within the specified temperature range.

[For water]

7. **Use the switch within the specified fluid and ambient temperature range.**

The fluid and ambient temperatures range for the switches is 0° to 50°C (and 0° to 90°C for high temperature fluid). Take measures to prevent freezing fluid when below 5°C, since this may cause damage to the switch and lead to a malfunction. Never use the switch in an environment where there are drastic temperature changes even when these temperatures fall within the specified temperature range.



Series PFA/PFW Specific Product Precautions 3

Be sure to read before handling. Refer to page 36 for safety instructions.

Maintenance

Warning

1. Perform periodical inspections to ensure proper operation of the switch.
Unexpected malfunctions may cause possible danger.
2. Take precautions when using the switch for an interlock circuit.
When a pressure switch is used for an interlock circuit, devise a multiple interlock system to prevent trouble or malfunctioning. Verify the operation of the switch and interlock function on a regular basis.
3. Do not disassemble or perform any conversion work on flow switches.

Measured Fluid

Warning

1. Check regulators and flow adjustment valves before introducing the fluid.
If pressure or flow rate beyond the specified range are applied to the switch, the sensor unit may be damaged.
[For air]
2. The fluids that the switch can measure accurately are nitrogen and dry air. However, only dry air can be measured with the high flow rate type.
Please note that accuracy cannot be guaranteed when other fluids are used.
3. Never use flammable fluids.
The flow velocity sensor heats up to approximately 150°C.
4. Install a filter or mist separator on the upstream side when there is a possibility of condensate and foreign matter being mixed in with the fluid.
The rectifying device built into the switch will be clogged up and accurate measurement will no longer be possible.
[For water]
5. The fluid that the switch can measure accurately is water.
Please note that accuracy cannot be guaranteed when other fluids are used.

Measured Fluid

Warning

6. Never use flammable fluids.
7. Install a filter on the upstream side when there is a possibility of condensate and foreign matter being mixed in with the fluid.
If foreign matter adheres to the switch's vortex generator or vortex detector, accurate measurement will no longer be possible.

Other

Warning

1. Since switch output remains OFF while a message is displayed after the power is turned on, start measurement after a value is displayed.
2. Perform settings after stopping control systems.
When the switch's initial setting and flow rate setting are performed, output maintains the condition prior to the settings. With the 100, 200, and 500/min type switches for air, output turns OFF when the switch's initial setting and flow rate setting are performed.
3. Do not apply excessive rotational force to the display unit.
The integrated type display unit can rotate 360°. Rotation is controlled by the stopper; however, the stopper may be damaged if the display unit is turned with excessive force.
[For air]
4. Be certain to turn on the power when the flow rate is at zero.
Allow an interval of 10 minutes after turning on the power, as there are some changes in the display.
5. Flow rate unit
Switch measures at mass flow rates without being influenced by temperature and pressure. The switches use /min as the flow rate indicator unit, in which the volumetric flow is substituted for mass flow at 0°C and 101.3kPa. The volumetric flow rate at 20°C, 101.3kPa, and 65%RH (ANR) can be displayed with the high flow rate type switches for air.

Detection principle of digital flow switch for air

A heated thermistor is installed in the passage, and fluid absorbs heat from the thermistor as it is introduced to the passage. The thermistor's resistance value increases as it loses heat. Since the resistance value increase ratio has a uniform relationship to the fluid velocity, the fluid velocity can be detected by measuring the resistance value. To further compensate the fluid and ambient temperature, the temperature sensor is also built into the switch to allow stable measurement within the operating temperature range.

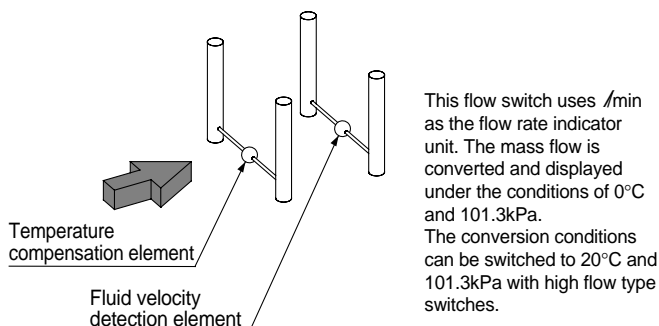

Detection principle of digital flow switch for water

When an elongated object (vortex generator) is placed in the flow, reciprocal vortices are generated on the downstream side. These vortices are stable under certain conditions, and their frequency is proportional to the flow velocity, resulting the following formula.

$$f = k \times v$$

f: Frequency of vortex v: Flow velocity k: Proportional constant (determined by the vortex generator's dimensions and shape).

Therefore, the flow rate can be measured by detecting this frequency.

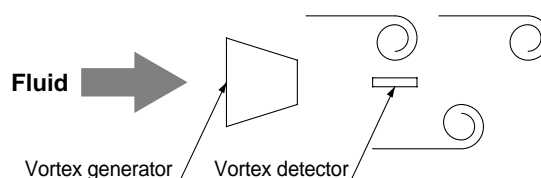

* Top view