

Low Friction Cylinders

Metal Seal Type



Compact Low Friction Cylinder Series *MQQ*

Series	Bore size (mm)	Operating pressure range (MPa)	Actuation speed (mm/s)
MQQT Standard type	10	0.005 to 0.5	0.3 to 300
	16		
	20		
MQQL Lateral load resisting type (Built-in ball bushing)	25	0.005 to 0.7	0.5 to 500
	30		
	40		



Lateral Load Resisting Low Friction Cylinder Series *MQM*

Series	Bore size (mm)	Operating pressure range (MPa)	Actuation speed (mm/s)
MQML Standard type	6 (Standard only)	ø6: 0.02 to 0.7 ø10 to ø25: 0.005 to 0.7	0.5 to 1000
	10		
	16		
MQML□□H High speed/frequency	20	0.01 to 0.7	5 to 3000
	25		

NEW



Low Friction Cylinder (Single Acting) Series *MQP*

Series	Bore size (mm)	Operating pressure range (MPa)	Thrust control standard (N)
MQP	ø4	0.001 to 0.7 (Except for moving parts weight)	0.01 to 8
	ø6		0.03 to 19
	ø10		0.08 to 50
	ø16		0.20 to 140
	ø20		0.30 to 200

Low pressure actuation

Minimal sliding resistance allows low pressure actuation at 0.005 MPa.
* Contact SMC regarding vacuum applications.

Low Friction Cylinders

Series MQQ

Series MQM

Metal seal structure with low sliding speed and an output control, which

Long service life

Long service life of 10,000 km or 100 million full cycles.

Low and uniform speed actuation

Smooth, uniform speed actuation ranges as low as 0.3 mm/s.

Rod: Carbon steel (chrome plated)
(Metal seal)

Sleeve: Special stainless steel
(Metal seal)

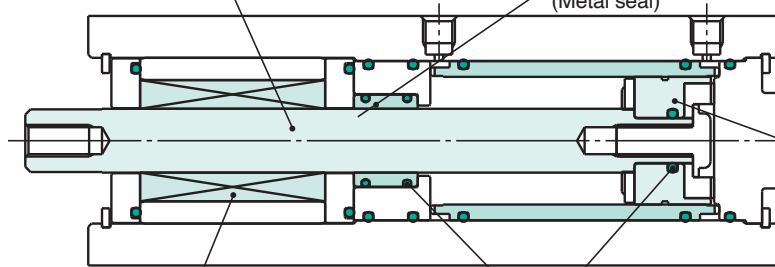

Piston: Special stainless steel
(Metal seal)

Lateral load resistance increased by built-in ball bushing

Patented floating mechanism facilitates stable operating resistance without galling due to shaft slippage.

* MQQT type made of fluororesin.

Low friction

Low sliding resistance and high stability allow force control as low as 0.05 N.
(Based on cylinder Piston area x Pressure accuracy)
No increased sliding resistance after periods of non-operation.

Lateral load resistance

Lateral load resistance is increased by built-in ball bushing.
(MQQL/MQML)

Series Variation

Series MQQ

Compact low friction cylinders designed for low pressure, low speed, uniform speed or low friction applications

Series	Bore size (mm)	Stroke (mm)								Operating pressure range (MPa)	Actuation speed (mm/s)
		10	20	30	40	50	60	75	100		
MQQT Standard type	10	●	●	●	●					0.005 to 0.5	0.3 to 300
	16	●	●	●	●	●					
	20	●	●	●	●	●	●				
MQQL Lateral load resisting type (Built-in ball bushing)	25	●	●	●	●	●		●	●	0.005 to 0.7	0.5 to 500
	30	●	●	●	●	●	●	●	●		
	40	●	●	●	●	●	●	●	●		



Series MQM

Lateral load resisting low friction cylinders for low pressure, low speed, uniform speed, low friction

Series	Bore size (mm)	Stroke (mm)						Operating pressure range (MPa)	Actuation speed (mm/s)
		15	30	45	60	75	100		
MQML Standard type	6 (standard only)	●	●	●	●			ø6: 0.02 to 0.7 ø10 to ø25: 0.005 to 0.7	0.5 to 1000
	10	●	●	●	●	●	●		
	16	●	●	●	●	●	●		
MQML□□H High speed/frequency	20	●	●	●	●	●	●	0.01 to 0.7	5 to 3000
	25	●	●	●	●	●	●		



(Metal Seal Type)

/ $\phi 10, \phi 16, \phi 20, \phi 25, \phi 30, \phi 40$

/ $\phi 6, \phi 10, \phi 16, \phi 20, \phi 25$

Application Examples

For pressure controlling with fine pressure variations

Applicable models: MQQT/MQML

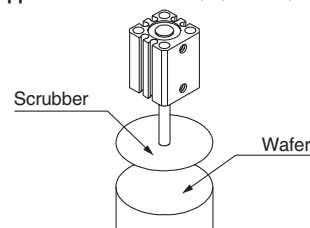

Polishing wafers

For cutting glasses and lenses, requiring constant force

Applicable models: MQQL/MQML

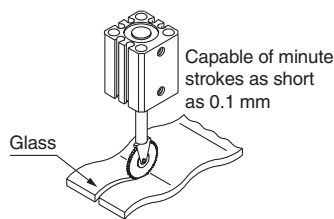

Cutting wavy surfaces

Tension controlling responding to very low pressure and minute pressure variations

Applicable models: MQQL/MQML

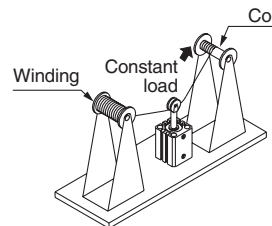

Coil winding

High speed, High frequency actuation

H type achieves speeds up to 3,000 mm/s (without fixed orifice), and continuous actuation up to 50 cycles per second. (MQML□□H)

For transferring precision components, etc., that require low or uniform speed actuation

Applicable models: MQQT/MQML

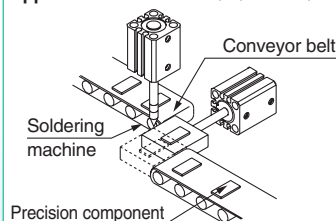

Transferring precision components

For eliminating non-conforming articles requiring high speed actuation

Applicable models: MQML/MQML□□H

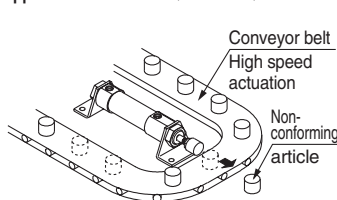

Eliminating non-conforming articles

For punching operations requiring high frequency actuation

Applicable models: MQML/MQML□□H

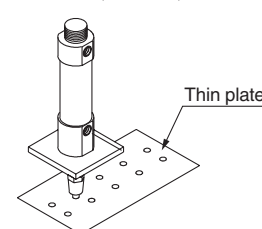

Punching

Recommended Circuit Examples

Example 1) Uniform & low speed actuation (no control of cylinder output)

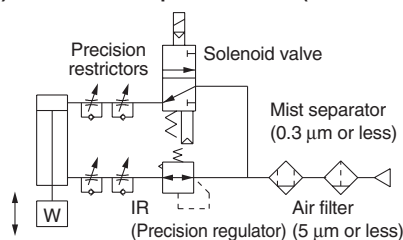

* When using a solenoid valve, use a metal seal type (Series VQ, VQZ, SQ, etc.).

Example 3) High speed & high frequency actuation

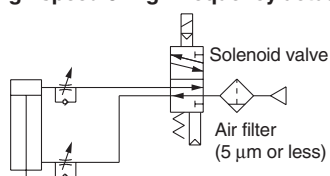

* When using a solenoid valve, use a metal seal type (Series VQ, VQZ, SQ, etc.).

Example 2) Low speed with output control

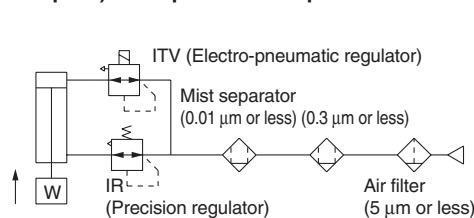

* When performing control of cylinder output, do not create a restriction circuit using a speed controller, etc. Pressure inside the cylinder will drop and control will become impossible. Always control actuation by means of pressure control.

Applications based on low friction specification

- 1) Operating resistance will vary with an offset load. Be sure to properly align the rod axis with the load and direction of movement when connecting. When an offset load is expected, provide a suitable mechanism such as a floating joint.
- 2) Use clean air (atmospheric pressure dew point temperature -10°C or less). Using the AM series mist separator (nominal filtration rating of $0.3\ \mu\text{m}$ or less), or the AM + AMD series (nominal filtration rating of $0.01\ \mu\text{m}$ or less) is recommended.

Low Friction Cylinder Series MQP



Fully covers a pressure force

No lurching

Even extremely small degree lurching such as 0.01 mm does not occur. In addition, special air supply to a bearing for fluid is unnecessary.

No piston

Sliding resistance is drastically decreased because the piston and the rod share the same shaft.

Special single acting/Piston retraction by external force

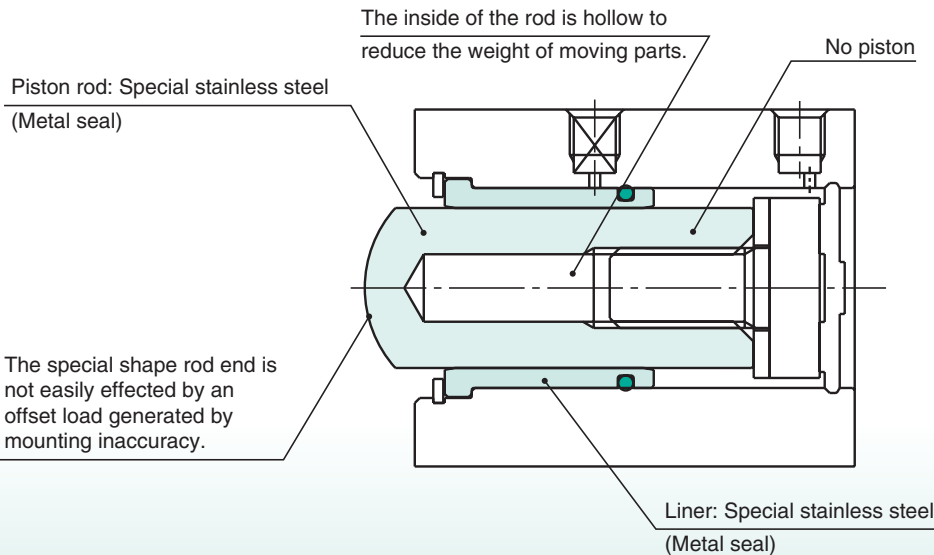
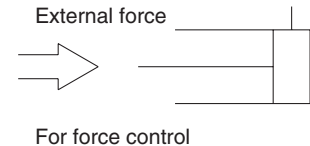

Reduced thrust dispersion

Dispersion of piston diameter: 3 μm or less
Readjusting thrust is not necessary when the cylinder is replaced.
Dispersion of thrust does not occur even more than one cylinder is connected to the same circuit, either. (Depends on the operation environment.)

Low friction and soft-touching

Possible to control the output in increments of 0.01 N. (Depends on the piston area of a cylinder x pressure accuracy)
In addition, sliding resistance does not change after periods of non-operation.

High-precision linear control

Delicate and precise linear movement control is possible.

Series MQP

Low friction cylinder suitable for low friction, force control.

Bore size [mm] (Pressure receiving diameter)	Stroke [mm]	Operating pressure range [MPa]	Weight of moving parts [g]	Thrust control standard [N]
ø 4	10	0.001 to 0.7 (Excluding the weight of moving parts)	4	0.01 to 8
ø 6			8	0.03 to 19
ø10			24	0.08 to 50
ø16			62	0.20 to 140
ø20			103	0.30 to 200

(Metal Seal Type/Single Acting)

/ø4, ø6, ø10, ø16, ø20

control range of 0.01 N to 200 N

Application Examples: For force control responding to a slight pressure fluctuation

Application examples for a single acting model

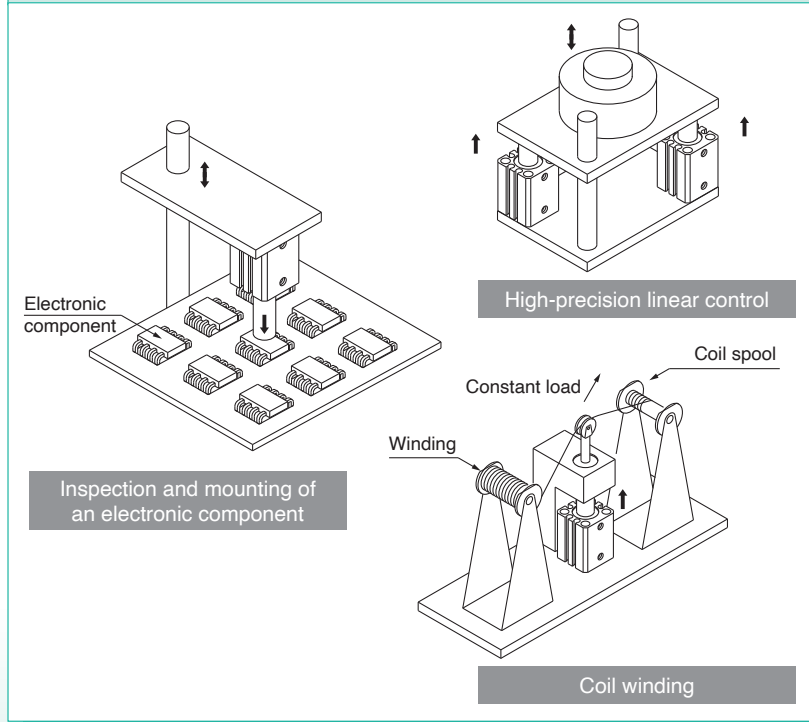

Application example for a double acting model

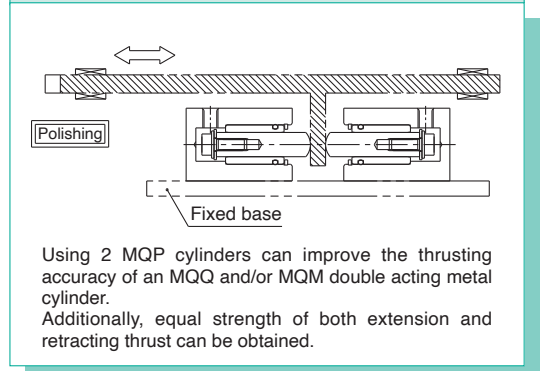

Recommended Circuit Examples

Example 1) Normal operation

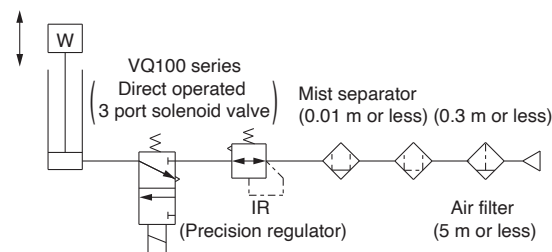

- 1) When using a solenoid valve, SMC recommends you use the VQ100-X42 series in which the lubricant in the main valve will not flow out.
- 2) Do not use a speed controller in the circuit. If it is used, accurate thrust control may not be possible because the internal pressure of a cylinder will drop. Be sure to employ pressure control for control operations.

Example 2) Soft-touch operation

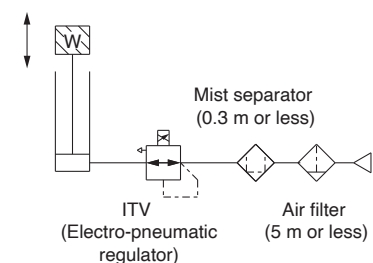

Made to Order

- Vacuum retraction cylinder
- Single acting, spring return type (Built-in springs)
- No exterior leakage (For clean rooms)
- Tubing with a maximum of ø40 (I.D.) is available.

Metal Seal

Compact Low Friction Cylinder

Series *MQQ*

ø10, ø16, ø20, ø25, ø30, ø40

How to Order

MQQ T B 10 10 D

Compact low friction specification

T	Standard type
L	Lateral load resisting type (Built-in ball bushing)

Type

Mounting

B	Through hole & Double end tapped (Standard)
L	Foot type
F	Front flange type
G	Rear flange type
D <small>Note)</small>	Double clevis type

Note) Available with the MQQL□ only.
* Mounting brackets are included when shipped, but unassembled.

Bore size

10	10 mm
16	16 mm
20	20 mm
25	25 mm
30	30 mm
40	40 mm

Body option

Nil	Standard (Rod end female thread)
M <small>Note)</small>	Rod end male thread

Note) A rod end thread adapter is attached.
* A rod end thread adapter is shipped being assembled.

Action

D	Double acting
----------	---------------

Cylinder stroke

Bore size (mm)	Standard stroke (mm)
10	10, 20, 30, 40
16	10, 20, 30, 40, 50, 60
20	10, 20, 30, 40, 50, 60
25	10, 20, 30, 40, 50, 75, 100
30	10, 20, 30, 40, 50, 75, 100
40	10, 20, 30, 40, 50, 75, 100

* Strokes are available in 1 mm increments by installing a spacer in standard stroke cylinders.

Port thread type

Nil	M thread	ø10 to ø20
	Rc	
TN	NPT	ø25 to ø40
TF	G	

 * The MQQ series is not auto switch capable.

Mounting Bracket Part No.

Bore size (mm)	Foot <small>Note 1)</small>	Flange	Double clevis	Rod end thread adapter (with nut)
10	CQS-L016	CQS-F016	CQS-D016	MQ10-M
16	CQS-L020	CQS-F020	CQS-D020	MQ16-M
20	CQS-L025	CQS-F025	CQS-D025	MQ20-M
25	MQ-L032	MQ-F032	MQ-D032	MQ25-M
30	MQ-L040	MQ-F040	MQ-D040	MQ28-M
40	CQ-L050	CQ-F050	MQ-D050	

Note 1) When ordering a foot bracket, order 2 pcs. for each cylinder.

Note 2) The following parts are included with a bracket respectively.

Foot, Flange Body mounting bolts

Double clevis Clevis pin, C type snap ring for shaft, Body mounting bolts

Specifications: Standard Type/MQQT



Bore size (mm)		10	16	20	25	30	40
Seal construction		Metal seal					
Action		Double acting, Single rod					
Fluid		Air					
Proof pressure		1.05 MPa					
Maximum operating pressure		0.5 MPa					
Minimum operating pressure <small>Note 1)</small>		0.005 MPa					
Ambient and fluid temperature		-10 to 80C					
Cushion		Rubber bumper (Standard)					
Lubrication <small>Note 2)</small>		Not required (Non-lube)					
Rod end thread		Female thread					
Rod end thread tolerance		JIS class 2					
Stroke length tolerance		$\begin{matrix} +1.0 \\ 0 \end{matrix}$					
Piston speed <small>Note 3)</small>		0.3 to 300 mm/s (Refer to page 19.)					
Total allowable leakage	Supply pressure 0.1 MPa	150 cm ³ /min or less	200 cm ³ /min or less	300 cm ³ /min or less	400 cm ³ /min or less	600 cm ³ /min or less	800 cm ³ /min or less
	Supply pressure 0.3 MPa	800 cm ³ /min or less	1000 cm ³ /min or less	1200 cm ³ /min or less	1600 cm ³ /min or less	2000 cm ³ /min or less	2400 cm ³ /min or less
	Supply pressure 0.5 MPa	1500 cm ³ /min or less	2000 cm ³ /min or less	3000 cm ³ /min or less	4000 cm ³ /min or less	6000 cm ³ /min or less	8000 cm ³ /min or less

Note 1) Value when horizontal. (Use clean, dry, and nonfreezing air) However, as the stroke increases, it will likely be affected by the weight of its moving parts and the pressure will likely increase by approx. 0.003 to 0.005 MPa due to an offset load from the weight of the rod.

Note 2) Refer to precautions on page 18 regarding lubrication.

Note 3) Control low speed actuation with differential pressure and a speed controller, etc. (Refer to recommended circuit examples for further details.)

Symbol

Double acting, Single rod

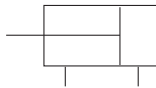

Specifications: Lateral Load Resisting Type/MQQL

Bore size (mm)		10	16	20	25	30	40
Seal construction		Metal seal					
Action		Double acting, Single rod					
Fluid		Air					
Proof pressure		1.05 MPa					
Maximum operating pressure		0.7 MPa					
Minimum operating pressure <small>Note 1)</small>		0.005 MPa					
Ambient and fluid temperature		-10 to 80C					
Cushion		Rubber bumper (Standard)					
Lubrication <small>Note 2)</small>		Not required (Non-lube)					
Rod end thread		Female thread					
Rod end thread tolerance		JIS class 2					
Stroke length tolerance		$\begin{matrix} +1.0 \\ 0 \end{matrix}$					
Piston speed <small>Note 3)</small>		0.5 to 500 mm/s (Refer to page 19.)					
Total allowable leakage	Supply pressure 0.1 MPa	150 cm ³ /min or less	200 cm ³ /min or less	300 cm ³ /min or less	400 cm ³ /min or less	600 cm ³ /min or less	800 cm ³ /min or less
	Supply pressure 0.3 MPa	800 cm ³ /min or less	1000 cm ³ /min or less	1200 cm ³ /min or less	1600 cm ³ /min or less	2000 cm ³ /min or less	2400 cm ³ /min or less
	Supply pressure 0.5 MPa	1500 cm ³ /min or less	2000 cm ³ /min or less	3000 cm ³ /min or less	4000 cm ³ /min or less	6000 cm ³ /min or less	8000 cm ³ /min or less

Note 1) Value when horizontal. (Use clean, dry, and nonfreezing air) However, as the stroke increases, it will likely be affected by the weight of its moving parts and the pressure will likely increase by approx. 0.003 to 0.005 MPa due to an offset load from the weight of the rod.

Note 2) Refer to precautions on page 18 regarding lubrication.

Note 3) Control low speed actuation with differential pressure and a speed controller, etc. (Refer to recommended circuit examples for further details.)

Weight: Standard Type/MQQT

Unit: g

Bore size (mm)	Cylinder stroke (mm)							
	10	20	30	40	50	60	75	100
10	94	118	142	166	—	—	—	—
16	166	206	246	286	326	366	—	—
20	228	290	352	414	476	538	—	—
25	395	487	579	671	763	—	993	1223
30	479	567	655	743	831	—	1052	1272
40	728	846	964	1082	1200	—	1495	1790

Weight: Lateral Load Resisting Type/MQQL (Built-in Ball Bushing)

Unit: g

Bore size (mm)	Cylinder stroke (mm)							
	10	20	30	40	50	60	75	100
10	148	172	196	220	—	—	—	—
16	284	324	364	404	444	484	—	—
20	383	445	507	569	631	693	—	—
25	552	644	736	828	920	—	1150	1380
30	911	999	1087	1175	1263	—	1485	1705
40	1337	1455	1573	1691	1809	—	2104	2399

Theoretical Output

Unit: N

Bore size (mm)	Rod size (mm)	Direction	Piston area (mm ²)	Operating pressure (MPa)						
				0.1	0.2	0.3	0.4	0.5	0.6	0.7
10	6	IN	50.3	5.0	10.1	15.1	20.1	25.2	30.2	35.2
		OUT	78.5	7.9	15.7	23.6	31.4	39.3	47.1	55.0
16	8	IN	145.8	14.9	29.2	43.7	58.3	72.9	87.5	102.1
		OUT	196.1	19.6	39.2	58.9	78.4	98.1	117.7	137.3
20	10	IN	235.6	23.6	47.1	70.7	94.2	117.8	141.4	164.9
		OUT	314.2	31.4	62.8	94.3	125.7	157.1	188.5	219.9
25	12	IN	377.8	37.8	75.6	113.3	151.1	188.9	226.7	262.5
		OUT	490.9	49.1	98.2	147.3	196.4	245.5	294.5	343.6
30	16	IN	505.8	50.6	101.2	151.8	202.4	253.0	303.6	354.2
		OUT	706.9	70.7	141.4	212.1	282.8	353.5	424.2	494.9
40	20	IN	1055.6	105.6	211.2	316.8	422.4	528.0	633.6	739.2
		OUT	1256.6	125.7	251.4	377.1	502.8	628.5	754.2	879.9

Series MQQ

Construction

Standard type: MQQT

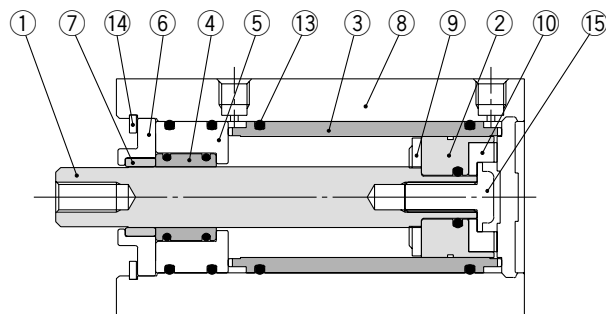

Lateral load resisting type: MQQL (Built-in ball bushing)

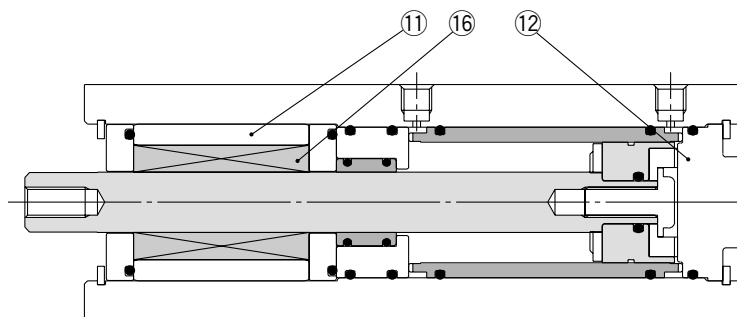

Component Parts

No.	Description	Material	Note
1	Rod	Carbon steel	Hard chrome plated
2	Piston	Special stainless steel	
3	Liner	Special stainless steel	
4	Sleeve	Special stainless steel	
5	Sleeve retainer	Aluminum alloy	
6	Plate	Aluminum alloy	Hard anodized
7	Guide	Fluororesin	
8	Cylinder tube	Aluminum alloy	Hard anodized
9	Bumper A	Polyurethane	
10	Bumper B	Polyurethane	
11	Bushing	Aluminum alloy	
12	Bottom plate	Aluminum alloy	Hard anodized
13	O-ring	NBR	
14	Retaining ring	Carbon tool steel	Nickel plated
15	Bolt	Carbon tool steel	Nickel plated
16	Ball bushing		

Mounting

Mounting bolts

a) Mounting type A (when using the mounting plate threads)

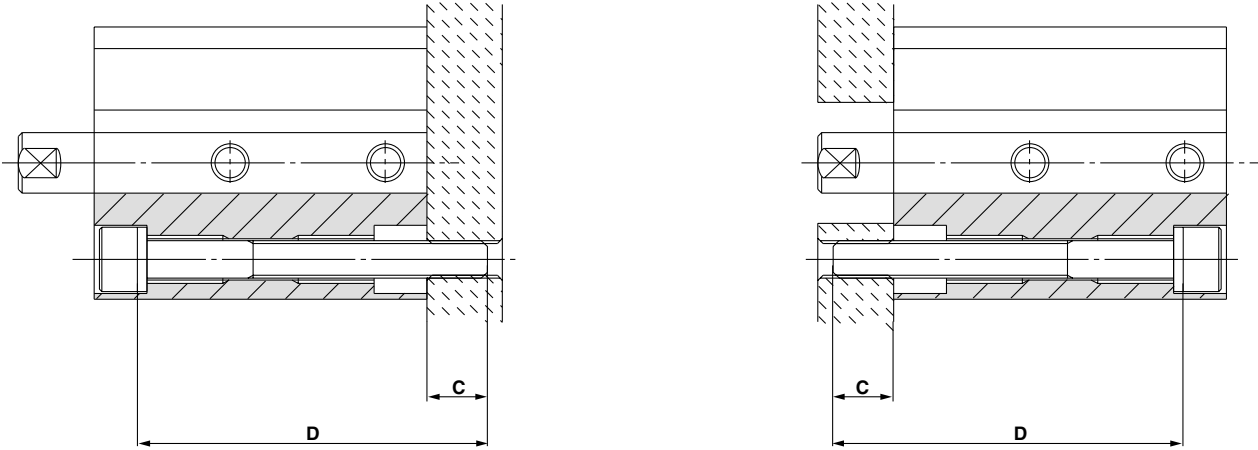

Note) Be sure to use a flat washer for the A type mounting.

b) Mounting type B (when using the cylinder tube threads)

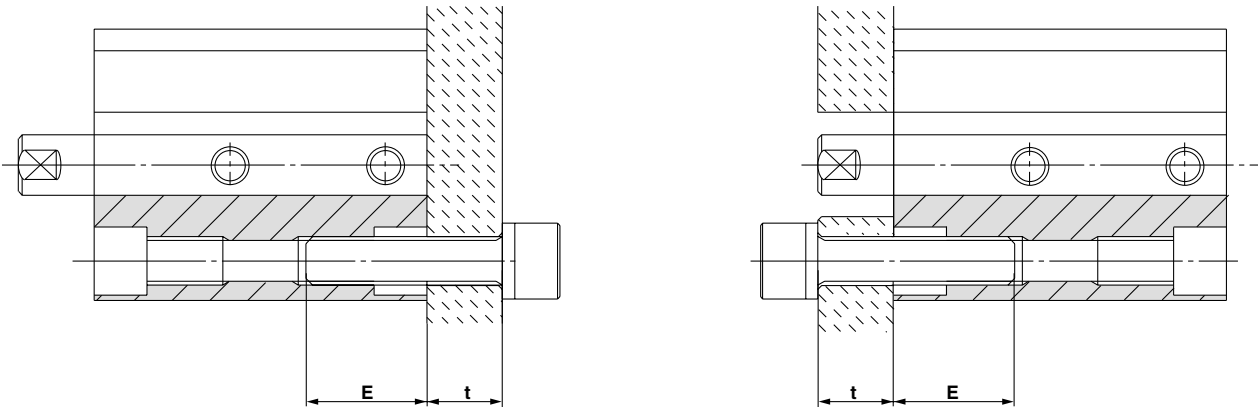

Compatible Mounting Bolt Dimensions

Model	Mounting type A			Mounting type B		
	Mounting bolt size	C (mm)	D: Bolt length (mm)	Mounting bolt size	E (mm)	
Standard type MQQT	MQQT \square B10- \square D	M3 x 0.5	7	35 + Stroke	M4 x 0.7	8 to 11
	MQQT \square B16- \square D	M5 x 0.8	7	35 + Stroke	M6 x 1	13 to 17
	MQQT \square B20- \square D		8.5	40 + Stroke		
	MQQT \square B25- \square D		9	45 + Stroke		
	MQQT \square B30- \square D		7.5	50 + Stroke		
	MQQT \square B40- \square D	M6 x 1	6	50 + Stroke	M8 x 1.25	16 to 22
Lateral load resisting type MQQL (Built-in ball bushing)	MQQL \square B10- \square D	M3 x 0.5	7	65 + Stroke	M4 x 0.7	8 to 11
	MQQL \square B16- \square D	M5 x 0.8	5.5	70 + Stroke	M6 x 1	13 to 17
	MQQL \square B20- \square D		8	80 + Stroke		
	MQQL \square B25- \square D		6.5	85 + Stroke		
	MQQL \square B30- \square D		7	105 + Stroke		
	MQQL \square B40- \square D	M6 x 1	7	105 + Stroke	M8 x 1.25	16 to 22

\square : Stroke

Series MQQ

Dimensions

Standard/Basic type (Through hole & Double end tapped): MQQTB

ø10, ø16, ø20

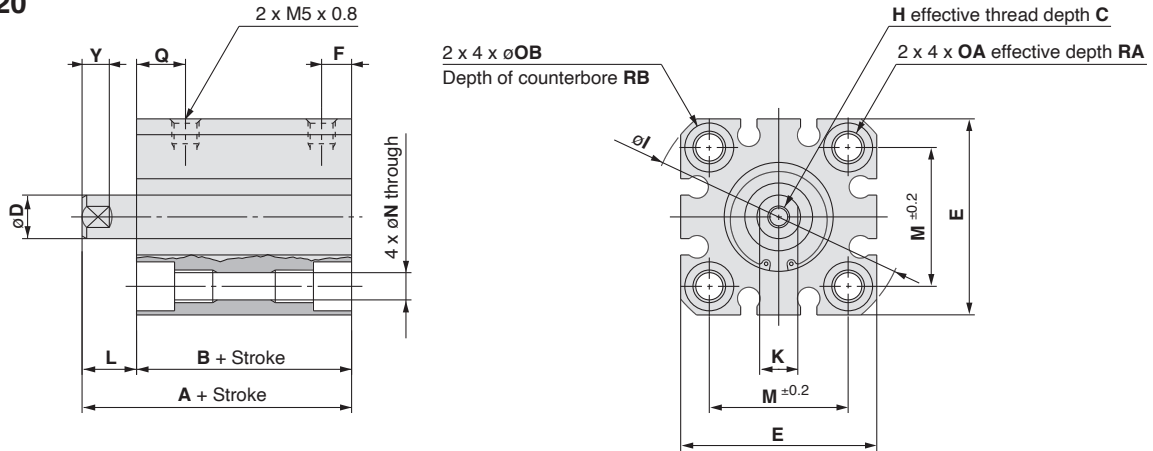

ø25, ø30, ø40

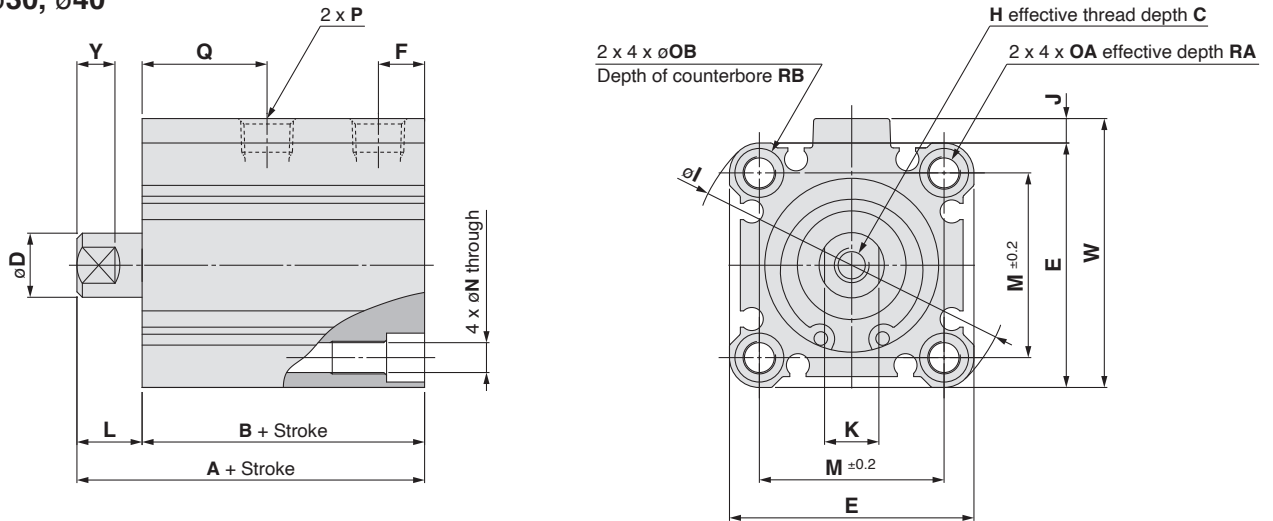

Bore size (mm)	Stroke range (mm)	A	B	C	D (Note)	E	F	H	I	J	K	L	M	N	OA	OB	P			Q	RA	RB	W	Y
																	-	TN	TF					
10	10 to 40	39.5	31.5	6	6 (5.8)	29	5.5	M3 x 0.5	38	-	5	8	20	3.5	M4 x 0.7	6.5	-	-	-	14.5	7	4	-	5
16	10 to 60	44	34	8	8 (7.8)	36	5.5	M4 x 0.7	47	-	7	10	25.5	5.4	M6 x 1.0	9	-	-	-	18	10	7	-	5
20	10 to 60	47.5	37.5	10	10 (9.8)	40	5.5	M5 x 0.8	52	-	8	10	28	5.4	M6 x 1.0	9	-	-	-	19.5	10	7	-	6
25	10 to 50, 75, 100	54	42	12	12 (11.8)	45	8.5	M6 x 1.0	60	4.5	10	12	34	5.5	M6 x 1.0	9	Rc1/8	NPT1/8	G1/8	23	10	7	49.5	7
30	10 to 50, 75, 100	60.5	48.5	13	16 (15.8)	52	8.5	M8 x 1.25	69	5	14	12	40	5.5	M6 x 1.0	9	Rc1/8	NPT1/8	G1/8	26	10	7	57	10
40	10 to 50, 75, 100	62	50	13	16 (15.8)	64	12	M8 x 1.25	86	7	14	12	50	6.6	M8 x 1.25	11	Rc1/4	NPT1/4	G1/4	26	14	8	71	10

Note) Figures in () are the dimensions for applying a wrench.

With rod end male thread: MQQ□-□DM

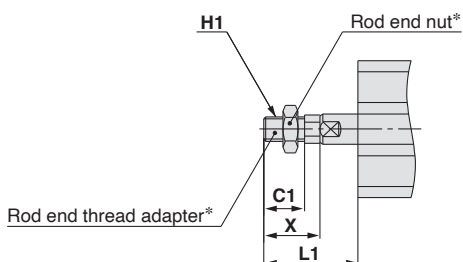

Bore size (mm)	(mm)			
	L1	C1	H1	X
10	23.5	10.5	M5 x 0.8	15.5
16	26.5	11.5	M6 x 1.0	16.5
20	28.5	13.5	M8 x 1.25	18.5
25	34.5	16.5	M10 x 1.25	22.5
30	40.5	22.5	M14 x 1.5	28.5
40	40.5	22.5	M14 x 1.5	28.5

* Refer to page 9 for details regarding the rod end thread adapter and the rod end nut.

Foot type: MQQTL

ø10, ø16, ø20

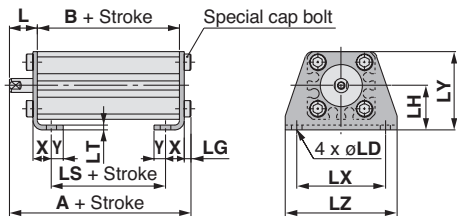

(mm)

Bore size (mm)	Stroke range (mm)	A	B	L	LD	LG	LH
10	10 to 40	44.3	31.5	8	4.5	2.8	19
16	10 to 60	51.2	34	10	6.6	4	24
20	10 to 60	54.7	37.5	10	6.6	4	26
25	10 to 50,75,100	61.2	42	12	6.6	4	30
30	10 to 50,75,100	67.7	48.5	12	6.6	4	33
40	10 to 50,75,100	70.2	50	12	9	5	39

ø25, ø30, ø40

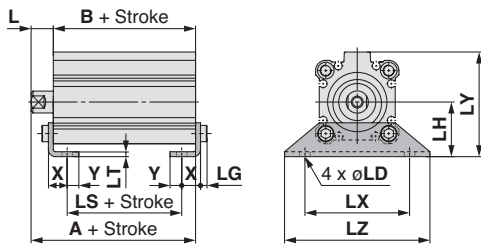

Bore size (mm)	LS	LT	LX	LY	LZ	X	Y
10	19.5	2	38	33.5	48	8	5
16	22	3.2	48	42	62	9.2	5.8
20	22.5	3.2	52	46	66	10.7	5.8
25	26	3.2	57	57	71	11.2	5.8
30	32.5	3.2	64	64	78	11.2	7
40	27	3.2	79	78	95	14.7	8

Rod side flange type: MQQTF

ø10, ø16, ø20

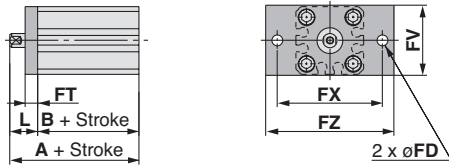

(mm)

Bore size (mm)	Stroke range (mm)	A	B	FD	FT	FV	FX
10	10 to 40	49.5	31.5	4.5	5.5	30	45
16	10 to 60	54	34	6.6	8	39	48
20	10 to 60	57.5	37.5	6.6	8	42	52
25	10 to 50,75,100	64	42	5.5	8	48	56
30	10 to 50,75,100	70.5	48.5	5.5	8	54	62
40	10 to 50,75,100	72	50	6.6	9	67	76

ø25, ø30, ø40

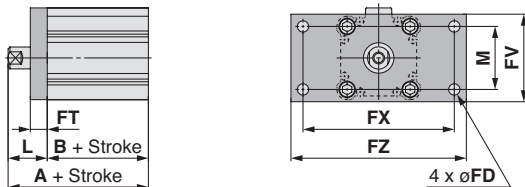

Bore size (mm)	FZ	L	M
10	55	18	—
16	60	20	—
20	64	20	—
25	65	22	34
30	72	22	40
40	89	22	50

Head side flange type: MQQTG

ø10, ø16, ø20

ø25, ø30, ø40

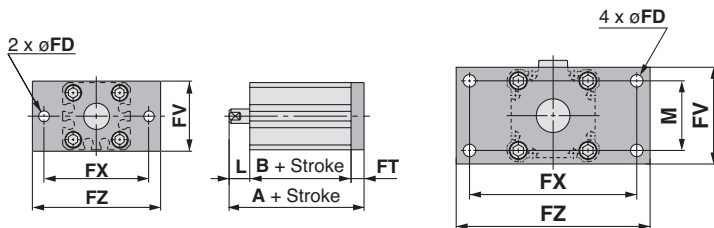

(mm)

Bore size (mm)	Stroke range (mm)	A	L
10	10 to 40	45	8
16	10 to 60	52	10
20	10 to 60	55.5	10
25	10 to 50,75,100	62	12
30	10 to 50,75,100	68.5	12
40	10 to 50,75,100	71	12

(Dimensions other than A and L are the same as the front flange type.)

Dimensions

Lateral load resisting/Basic type (Through hole & Double end tapped): MQQLB ø10, ø16, ø20

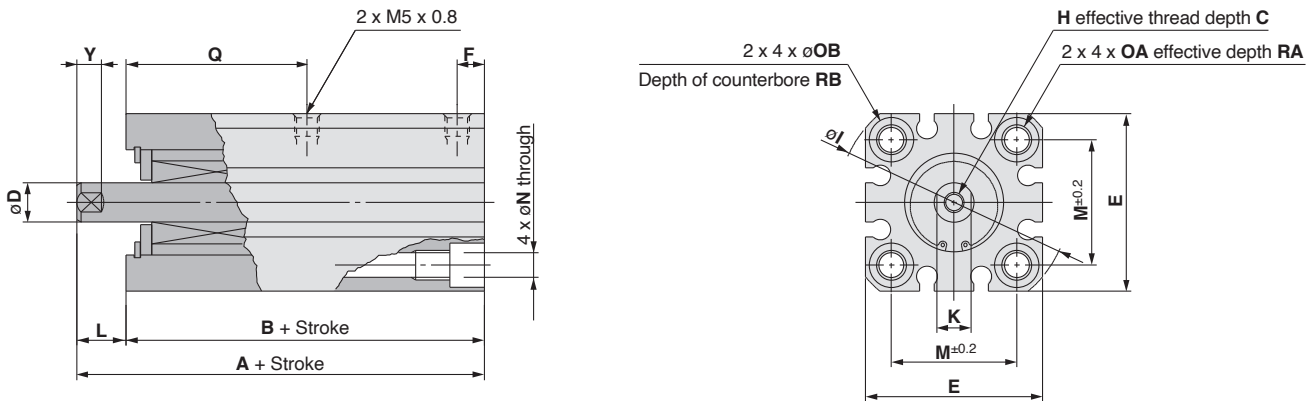

ø25, ø30, ø40

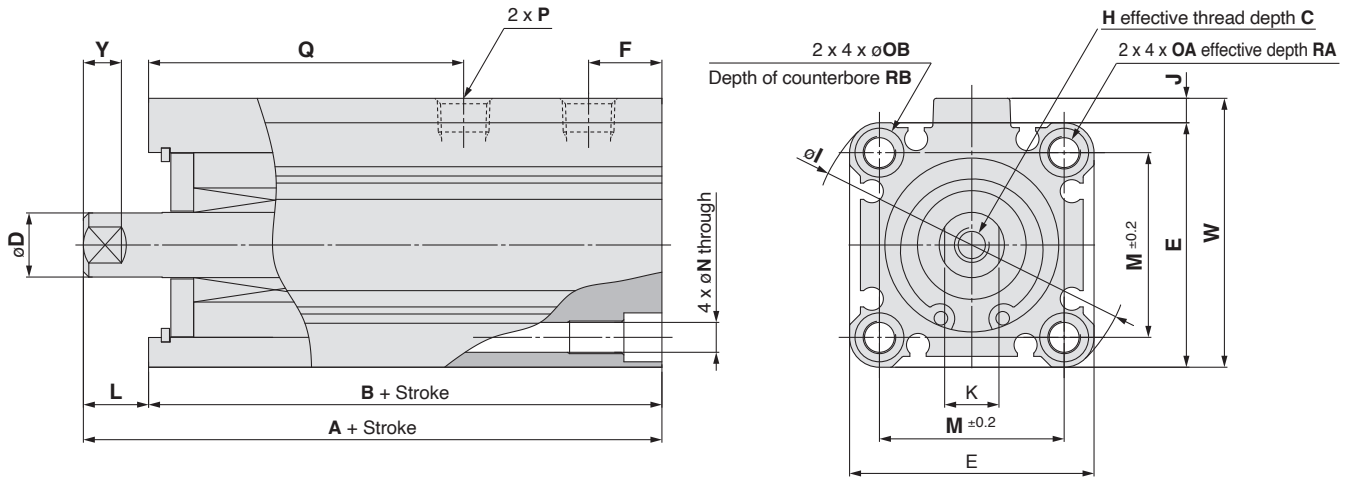

Bore size (mm)	Stroke range (mm)	A	B	C	D (Note)	E	F	H	I	J	K	L	M	N	OA	OB	P			Q	RA	RB	W	Y
																	-	TN	TF					
10	10 to 40	69.5	61.5	6	6 (5.8)	29	9	M3 x 0.5	38	-	5	8	20	3.5	M4 x 0.7	6.5	-	-	-	39.5	7	4	-	5
16	10 to 60	80.5	70.5	8	8 (7.8)	36	11.5	M4 x 0.7	47	-	7	10	25.5	5.4	M6 x 1.0	9	-	-	-	48.5	10	7	-	5
20	10 to 60	89	79	10	10 (9.8)	40	12	M5 x 0.8	52	-	8	10	28	5.4	M6 x 1.0	9	-	-	-	55	10	7	-	6
25	10 to 50, 75, 100	96.5	84.5	12	12 (11.8)	45	13.5	M6 x 1.0	60	4.5	10	12	34	5.5	M6 x 1.0	9	Rc1/8	NPT1/8	G1/8	58	10	7	49.5	7
30	10 to 50, 75, 100	116	104	13	16 (15.8)	52	17.5	M8 x 1.25	69	5	14	12	40	5.5	M6 x 1.0	9	Rc1/8	NPT1/8	G1/8	71	10	7	57	10
40	10 to 50, 75, 100	116	104	13	16 (15.8)	64	17.5	M8 x 1.25	86	7	14	12	50	6.6	M8 x 1.25	11	Rc1/4	NPT1/4	G1/4	71	14	8	71	10

Note) Figures in () are the dimensions for applying a wrench.

With rod end male thread: MQQ□-□DM

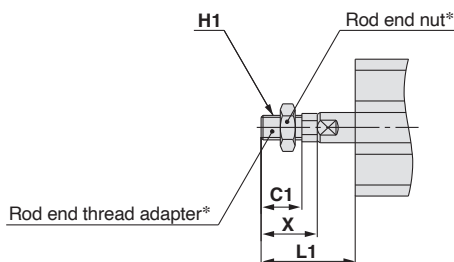

Bore size (mm)	L1	C1	H1	X
10	23.5	10.5	M5 x 0.8	15.5
16	26.5	11.5	M6 x 1.0	16.5
20	28.5	13.5	M8 x 1.25	18.5
25	34.5	16.5	M10 x 1.25	22.5
30	40.5	22.5	M14 x 1.5	28.5
40	40.5	22.5	M14 x 1.5	28.5

* Refer to page 9 for details regarding the rod end thread adapter and the rod end nut.

Foot type: MQQLL

ø10, ø16, ø20

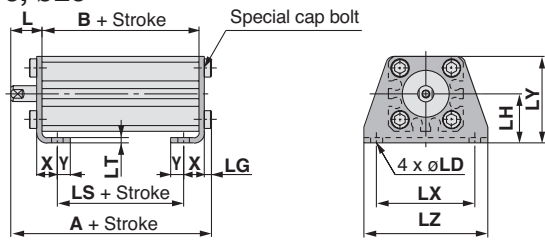

ø25, ø30, ø40

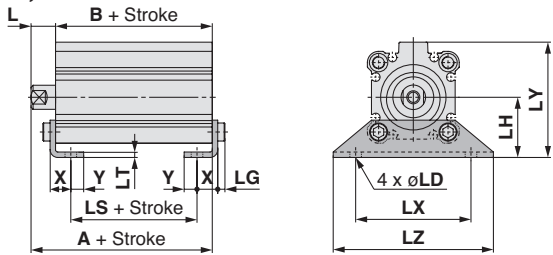

Rod side flange type: MQQLF

ø10, ø16, ø20

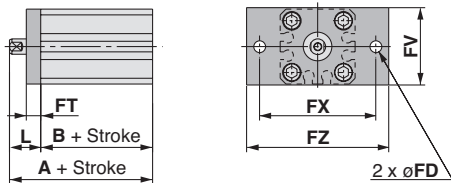

ø25, ø30, ø40

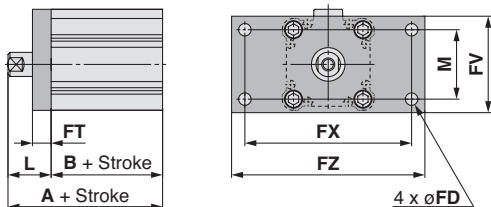

Head side flange type: MQQLG

ø10, ø16, ø20

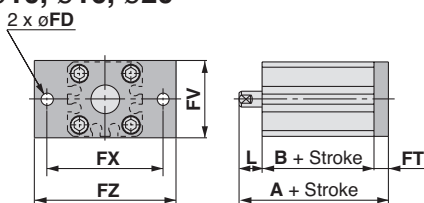

ø25, ø30, ø40

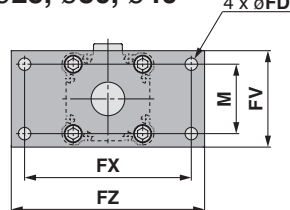

Double clevis type: MQQLD

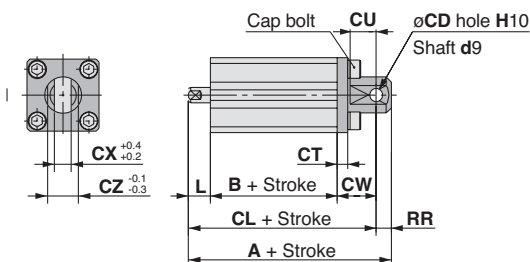

(mm)

Bore size (mm)	Stroke range (mm)	A	B	L	LD	LG	LH
10	10 to 40	74.3	61.5	8	4.5	2.8	19
16	10 to 60	87.7	70.5	10	6.6	4	24
20	10 to 60	96.2	79	10	6.6	4	26
25	10 to 50,75,100	103.7	84.5	12	6.6	4	30
30	10 to 50,75,100	123.2	104	12	6.6	4	33
40	10 to 50,75,100	124.2	104	12	9	5	39

Bore size (mm)	LS	LT	LX	LY	LZ	X	Y
10	49.5	2	38	33.5	48	8	5
16	58.5	3.2	48	42	62	9.2	5.8
20	64	3.2	52	46	66	10.7	5.8
25	68.5	3.2	57	57	71	11.2	5.8
30	88	3.2	64	64	78	11.2	7
40	81	3.2	79	78	95	14.7	8

(mm)

Bore size (mm)	Stroke range (mm)	A	B	FD	FT	FV	FX
10	10 to 40	79.5	61.5	4.5	5.5	30	45
16	10 to 60	90.5	70.5	6.6	8	39	48
20	10 to 60	99	79	6.6	8	42	52
25	10 to 50,75,100	106.5	84.5	5.5	8	48	56
30	10 to 50,75,100	126	104	5.5	8	54	62
40	10 to 50,75,100	126	104	6.6	9	67	76

Bore size (mm)	FZ	L	M
10	55	18	—
16	60	20	—
20	64	20	—
25	65	22	34
30	72	22	40
40	89	22	50

(mm)

Bore size (mm)	Stroke range (mm)	A	L
10	10 to 40	75	8
16	10 to 60	88.5	10
20	10 to 60	97	10
25	10 to 50,75,100	104.5	12
30	10 to 50,75,100	124	12
40	10 to 50,75,100	125	12

(Dimensions other than A and L are the same as the front flange type.)

(mm)

Bore size (mm)	Stroke range (mm)	A	B	CD	CL	CT	CU
10	10 to 40	90.5	61.5	5	84.5	4	10
16	10 to 60	107.5	70.5	8	98.5	5	12
20	10 to 60	119	79	10	109	5	14
25	10 to 50,75,100	126.5	84.5	10	116.5	5	14
30	10 to 50,75,100	148	104	10	138	6	14
40	10 to 50,75,100	158	104	14	144	7	20

Bore size (mm)	CW	CX	CZ	L	RR
10	15	6.5	12	8	6
16	18	8	16	10	9
20	20	10	20	10	10
25	20	18	36	12	10
30	22	18	36	12	10
40	28	22	44	12	14

Series MQQ

Accessory Dimensions

Rod end thread adapter

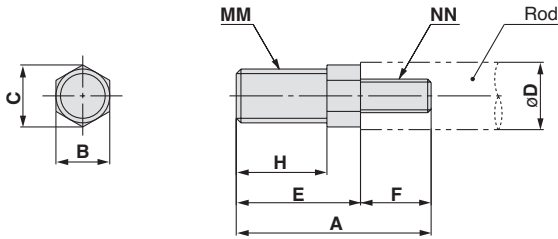

Part no.	Applicable bore size (mm)	A	B	C	D	E	F
MQ10-M	10	20.5	8	9.2	6	15.5	5
MQ16-M	16	22.5	8	9.2	8	16.5	6
MQ20-M	20	24.5	8	9.2	10	18.5	6
MQ25-M	25	33.5	10	11.5	12	22.5	11
MQ28-M	30, 40	40.5	14	16	16	28.5	12

Part no.	Applicable bore size (mm)	H	MM	NN
MQ10-M	10	10.5	M5 x 0.8	M3 x 0.5
MQ16-M	16	11.5	M6 x 1.0	M4 x 0.7
MQ20-M	20	13.5	M8 x 1.25	M5 x 0.8
MQ25-M	25	16.5	M10 x 1.25	M6 x 1.0
MQ28-M	30, 40	22.5	M14 x 1.5	M8 x 1.25

Rod end nut

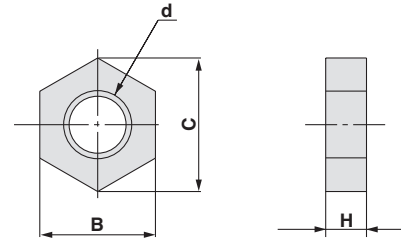

Part no.	Applicable bore size (mm)	B	C	d	H
NTJ-015C	10	8	9.2	M5 x 0.8	4
NT-015A	16	10	11.5	M6 x 1.0	5
NT-02	20	13	15	M8 x 1.25	5
NT-03	25	17	19.6	M10 x 1.25	6
NT-04	30, 40	22	25.4	M14 x 1.5	8

Clevis pin

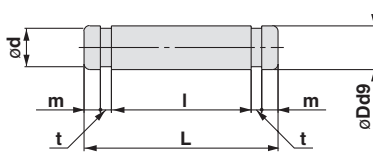

Part no.	Applicable bore size (mm)	Dd9	L	d	l	m	t	Applicable snap ring
IY-J015	10	$5_{-0.030}^{-0.040}$	16.6	4.8	12.2	1.5	0.7	C type 5 for shaft
IY-G02	16	$8_{-0.040}^{-0.076}$	21	7.6	16.2	1.5	0.9	C type 8 for shaft
IY-G03	20	$10_{-0.040}^{-0.076}$	25.6	9.6	20.2	1.55	1.15	C type 10 for shaft
IY-G04	25, 30	$10_{-0.040}^{-0.076}$	41.6	9.6	36.2	1.55	1.15	C type 10 for shaft
IY-G05	40	$14_{-0.050}^{-0.093}$	50.6	13.4	44.2	2.05	1.15	C type 14 for shaft

Metal Seal

Lateral Load Resisting Low Friction Cylinder Series **MQM** ø6, ø10, ø16, ø20, ø25

How to Order

MQML B 10 15 D

Lateral load resisting low friction specification

Type

L Lateral load resisting type (Built-in basic bushing)

Mounting

B	Basic type
L	Foot type
F	Front flange type
G	Rear flange type (Except for ø6)
C <small>Note 1)</small>	Single clevis type (Non-integrated type)
D <small>Note 2)</small>	Double clevis type

Note 1) Bore size: 20, 25 mm only

* Mounting brackets are included when shipped, but unassembled. (Except for clevis type.)

Note 2) ø6, ø10, ø16 Integrated type
ø20, ø25 Non-integrated type

Bore size

6	6 mm
10	10 mm
16	16 mm
20	20 mm
25	25 mm

Action

D Double acting

Cylinder stroke

Bore size (mm)	Standard stroke (mm)
6	15, 30, 45, 60
10	15, 30, 45, 60, 75, 100
16	15, 30, 45, 60, 75, 100
20	15, 30, 45, 60, 75, 100
25	15, 30, 45, 60, 75, 100

* Strokes are available in 1mm increments by installing spacers in standard stroke cylinders.

Function

Nil	Standard type
H <small>Note)</small>	High speed/High frequency type (Without fixed orifice)

Note) Except for 6 mm bore size.

Port thread type

Nil	M thread	ø6 to ø16
	Rc	
TN	NPT	ø20, ø25
TF	G	

 * The MQM series is not auto switch capable.

Mounting Bracket/Accessories

Mounting bracket		B: Basic	L: Foot	F: Front flange	G: Rear flange	C: Single clevis	D: Double clevis	Note
Standard	Mounting nut <small>Note 1)</small>	● (1 pc.)	● (2 pcs.)	● (1 pc.)	● (1 pc.)	— <small>Note 1)</small>	— <small>Note 2)</small>	
	Rod end nut	●	●	●	●	●	●	
	Clevis pin	—	—	—	—	—	●	
Option	T-bracket	—	—	—	—	—	●	With pin

Note 1) Mounting nut is not included with the integral clevis, single clevis and double clevis types.

Note 2) Pin and snap ring are packed with the double clevis type.

Mounting Bracket Part No.

Bore size (mm)	Foot <small>Note 1)</small>	Flange	Single clevis	Double clevis (with pin) <small>Note 2)</small>	T-bracket <small>Note 3)</small>
6	CJK-L016C	CJK-F016C	—	—	CJ-T010C
10	MQM-L010		—	—	
16	MQM-L016	CLJ-F016B	—	—	CJ-T016C
20	CM-L020B	CM-F020B	CM-C020B	CM-D020B	—
25	CM-L032B	CM-F032B	CM-C032B	CM-D032B	—

Note 1) Two foot brackets and one mounting nut are included.

Note 2) Clevis pin and snap ring are included in package.

Note 3) T-bracket is applicable to the double clevis type (D).

Series MQM



Symbol
Double acting, Single rod

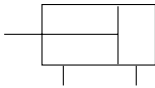

Specifications

Bore size (mm)		6	10	16	20	25
Seal construction		Metal seal				
Action		Double acting, Single rod				
Fluid		Air				
Proof pressure		1.05 MPa				
Maximum operating pressure		0.7 MPa				
Minimum operating pressure ^{Note 1)}	Standard type	0.02MPa	0.005 MPa			
	H (High speed/High frequency type)	—	0.01 MPa			
Ambient and fluid temperature		-10 to 80°C				
Cushion		Rubber bumper (Standard)				
Lubrication ^{Note 2)}		Not required (Non-lube)				
Rod end thread tolerance		JIS class 2				
Stroke length tolerance		+1.0 0				
Piston speed ^{Note 3)}	Standard type	0.5 to 1000 mm/s (Refer to page 20.)				
	H (High speed/High frequency type)	—	5 to 3000 mm/s (Refer to page 20.)			
Total allowable leakage	Supply pressure 0.1 MPa	150 cm ³ /min or less	250 cm ³ /min or less	300 cm ³ /min or less		
	Supply pressure 0.3 MPa	800 cm ³ /min or less	1000 cm ³ /min or less	1200 cm ³ /min or less		
	Supply pressure 0.5 MPa	1500 cm ³ /min or less	2500 cm ³ /min or less	3000 cm ³ /min or less		

Note 1) Value when horizontal. (Use clean, dry, and nonfreezing air) However, as the stroke increases, it will likely be affected by the weight of its moving parts and the pressure will likely increase by approx. 0.003 to 0.005 MPa due to an offset load from the weight of the rod.

Note 2) Refer to precautions on page 18 regarding lubrication.

Note 3) Control low speed actuation with differential pressure and a speed controller, etc. (Refer to recommended circuit examples for further details.)

Weight: Standard Type, High Speed/High Frequency Type

Unit: g

Bore size (mm)	Cylinder stroke (mm)					
	15	30	45	60	75	100
6	52.5	60.7	68.9	77.1	—	—
10	92.4	102.7	113.0	123.3	133.6	143.9
16	152.4	175.2	198.0	220.8	243.6	266.4
20	349.8	392.6	435.4	478.2	521.0	563.8
25	460.8	510.0	559.2	608.4	657.6	706.8

Theoretical Output



Unit: N

Bore size (mm)	Rod size (mm)	Direction	Piston area (mm ²)	Operating pressure (MPa)						
				0.1	0.2	0.3	0.4	0.5	0.6	0.7
6	4	IN	15.7	1.6	3.2	4.7	6.3	7.9	9.4	11.0
		OUT	28.3	2.8	5.7	8.5	11.3	14.2	17.0	19.8
10	4	IN	66.0	6.6	13.2	19.8	26.4	33.0	39.6	46.2
		OUT	78.5	7.9	15.7	23.6	31.4	39.3	47.1	55.0
16	5	IN	181.4	18.1	36.3	54.4	72.6	90.7	108.8	127.0
		OUT	201.1	20.1	40.2	60.3	80.4	100.6	120.7	140.8
20	8	IN	263.9	26.4	52.8	79.2	105.6	132.0	158.3	184.7
		OUT	314.2	31.4	62.8	94.3	125.7	157.1	188.5	219.9
25	10	IN	412.3	41.2	82.5	123.7	164.9	206.2	247.4	288.6
		OUT	490.9	49.1	98.2	147.3	196.4	245.5	294.5	343.6

Construction

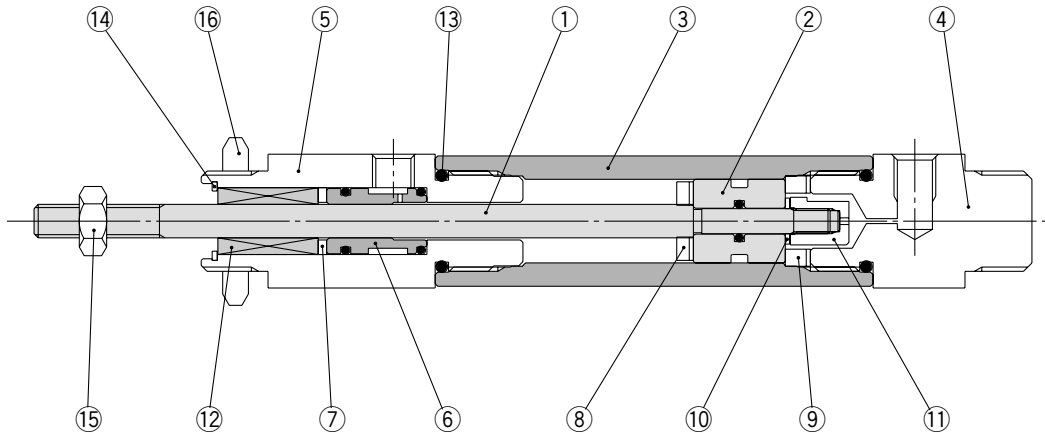

Component Parts

No.	Description	Material	Note
1	Rod	Carbon steel	Hard chrome plated
2	Piston	Special stainless steel	
3	Tube	Special stainless steel	
4	Head cover	Aluminum alloy	Hard anodized
5	Rod cover	Aluminum alloy	Hard anodized
6	Sleeve	Special stainless steel	
7	Seat	NBR	
8	Bumper A	Polyurethane	
9	Bumper B	Polyurethane	
10	Bumper C	Polyurethane	
11	Nut	Aluminum alloy	
12	Ball bushing		
13	O-ring	NBR	
14	Snap ring	Carbon tool steel	Nickel plated
15	Rod end nut	Steel	Nickel plated
16	Mounting nut	Steel	

Series MQM

Dimensions

Basic type: MQMLB

ø6

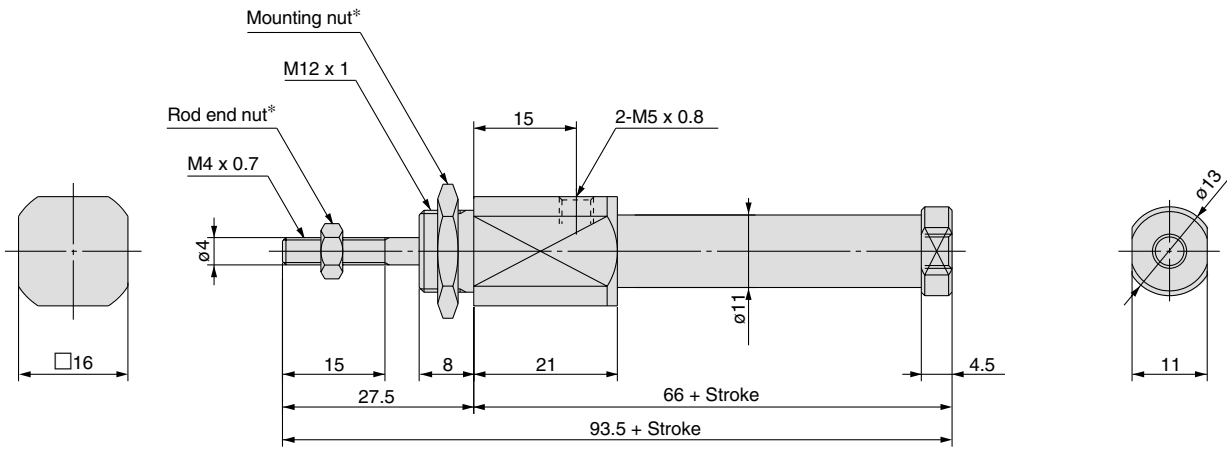

ø10, ø16, ø20, ø25

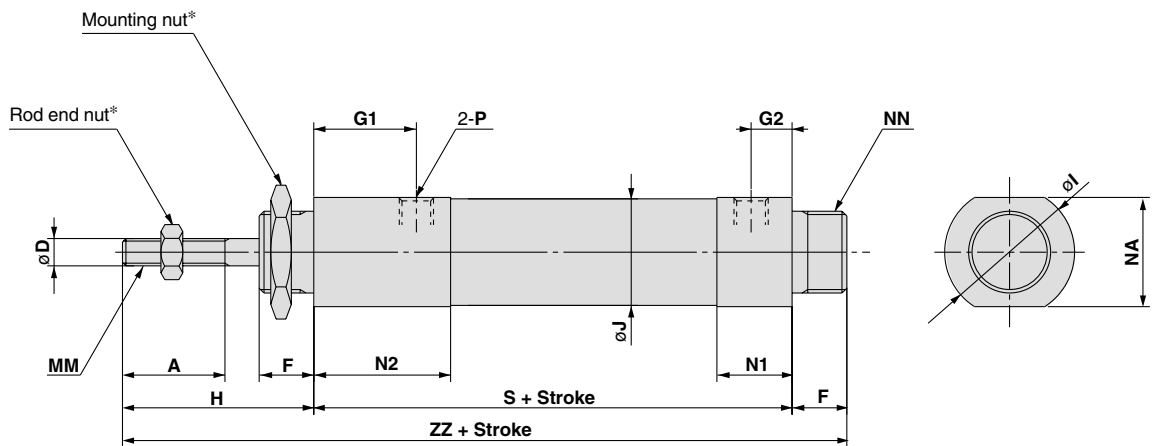

(mm)

Bore size (mm)	A	D	F	G1	G2	H	I	J	MM	N1	N2	NA	NN	P			S	ZZ
														—	TN	TF		
10	15	4	8	15	6	28	18.5	16	M4 x 0.7	11	20	16	M12 x 1	M5 x 0.8	—	—	65	101
16	15	5	10	15	6	30	22	22	M5 x 0.8	12	21	19.5	M14 x 1	M5 x 0.8	—	—	74	114
20	18	8	13	25	8.5	40.5	31.5	28.5	M8 x 1.25	20.5	33	29	M20 x 1.5	Rc1/8	NPT1/8	G1/8	97.5	151
25	18	10	13	30	8.5	44.5	34.5	32	M10 x 1.25	20.5	38	32	M26 x 1.5	Rc1/8	NPT1/8	G1/8	102.5	160

* Refer to page 17 for details regarding the rod end nut and the mounting nut.

Refer to the basic type on page 13 for other dimensions.

Dimensions

Foot type: MQMLL

ø6

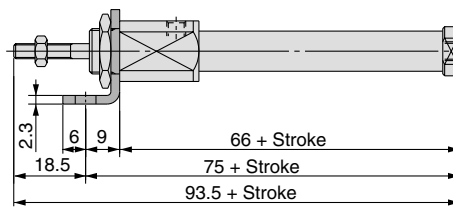
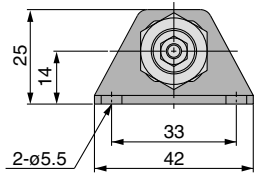

ø10, ø16, ø20, ø25

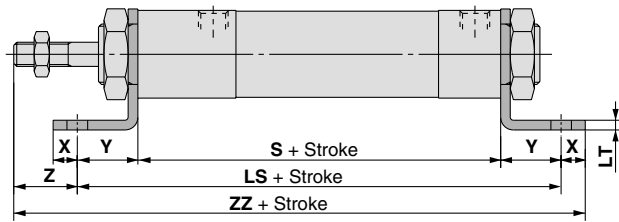
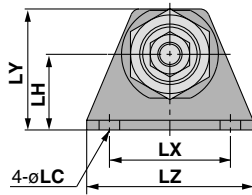

(mm)

Bore size (mm)	LC	LH	LS	LT	LX	LY	LZ	S	X	Y	Z	ZZ
10	5.5	14	83	2.3	33	25	42	65	6	9	19	108
16	5.5	18	92	2.3	42	30	54	74	6	9	21	119
20	6.8	25	137.5	3.2	40	40	55	97.5	8	20	20.5	166
25	6.8	28	142.5	3.2	40	47	55	102.5	8	20	24.5	175

Front flange type: MQMLF

ø6

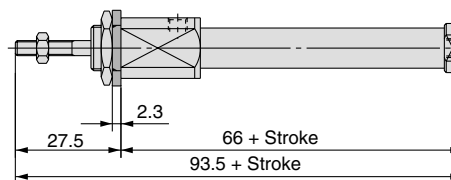
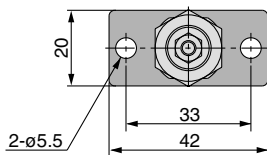

ø10, ø16, ø20, ø25

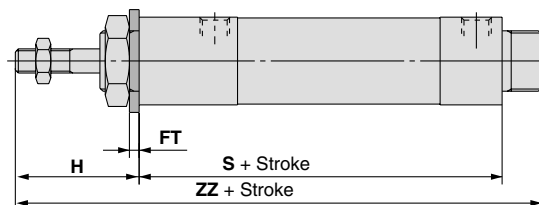
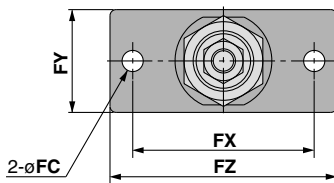

(mm)

Bore size (mm)	FC	FT	FX	FY	FZ	H	S	ZZ
10	5.5	2.3	33	20	42	28	65	101
16	5.5	2.3	42	24	54	30	74	114
20	7	4	60	34	75	40.5	97.5	151
25	7	4	60	40	75	44.5	102.5	160

Series MQM

Refer to the basic type on page 13 for other dimensions.

Dimensions

Rear flange type: MQMLG (Except for $\phi 6$)
 $\phi 10$, $\phi 16$, $\phi 20$, $\phi 25$

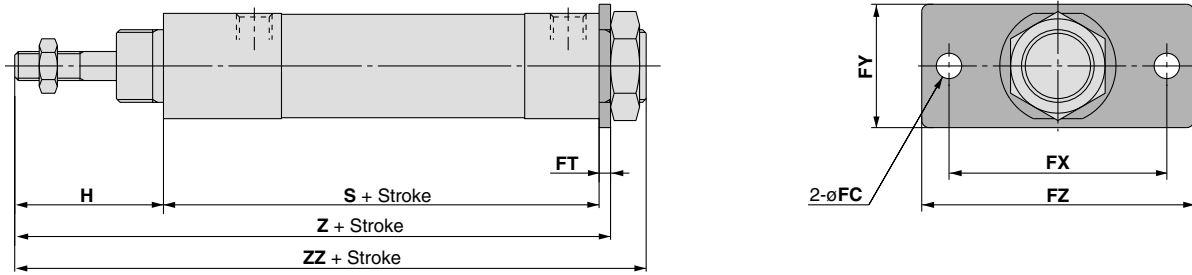

(mm)

Bore size (mm)	FC	FT	FX	FY	FZ	H	S	Z	ZZ
10	5.5	2.3	33	20	42	28	65	95.3	101
16	5.5	2.3	42	24	54	30	74	106.3	114
20	7	4	60	34	75	40.5	97.5	142	151
25	7	4	60	40	75	44.5	102.5	151	160

Single clevis type: MQMLC ($\phi 20$ and $\phi 25$ only)
 $\phi 20$, $\phi 25$ (Non-integrated type)

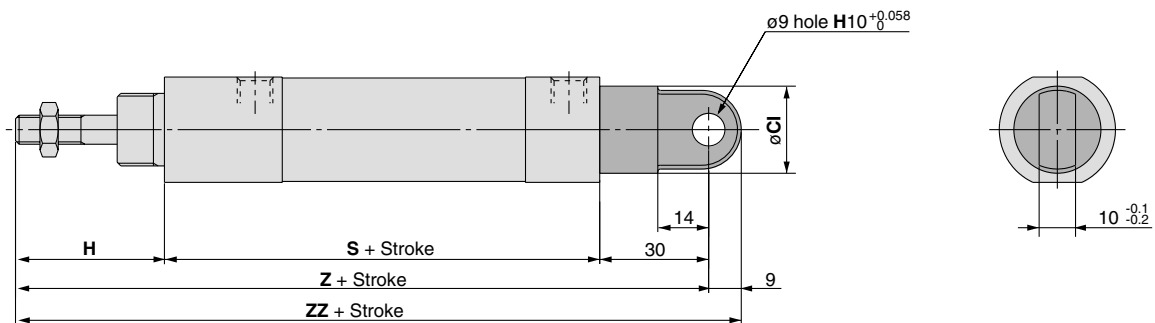

(mm)

Bore size (mm)	CI	H	S	Z	ZZ
20	24	40.5	97.5	168	177
25	30	44.5	102.5	177	186

Refer to the basic type on page 13 for other dimensions.

Dimensions

**Double clevis type: MQMLD
ø6, ø10, ø16 (Integrated type)**

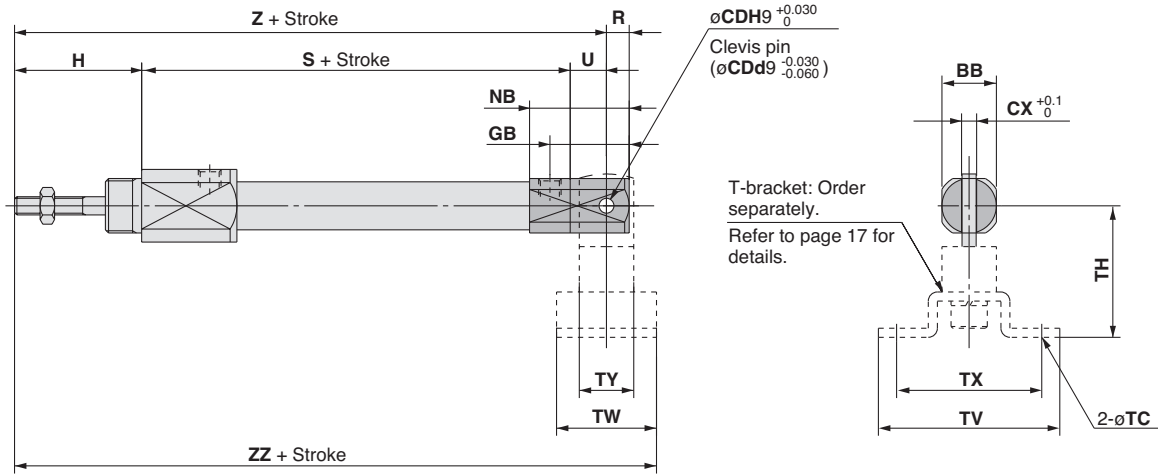

(mm)

Bore size (mm)	BB	CD	CX	GB	H	NB	R	S	U	Z	ZZ
6	12	3.3	3.3	17.5	27.5	22	5	70.5	8	106	117
10	12	3.3	3.3	19	28	24	5	65	8	101	112
16	18	5	6.6	24	30	30	8	74	10	114	128

T-bracket Related Dimensions (Note)

Part no.	Applicable bore size (mm)	TC	TH	TV	TW	TX	TY
CJ-T010C	6, 10	4.5	29	40	22	32	12
CJ-T016C	16	5.5	35	48	28	38	16

Note) Refer to page 17 for details.

ø20, ø25 (Non-integrated type)

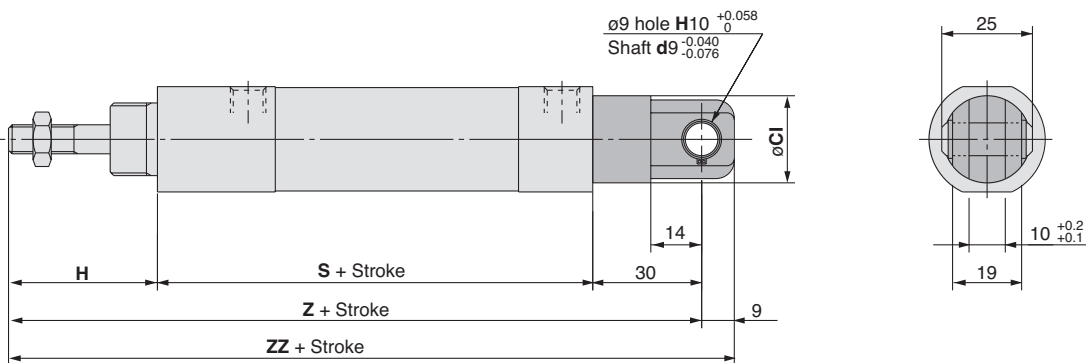

(mm)

Bore size (mm)	CI	H	S	Z	ZZ
20	24	40.5	97.5	168	177
25	30	44.5	102.5	177	186

Series MQM

Accessory Dimensions

Mounting nut

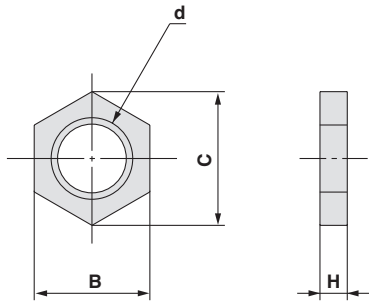

Rod end nut

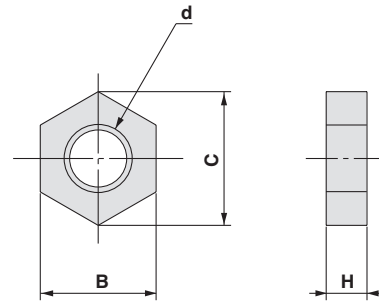

Material: Carbon steel

Part no.	Applicable bore size (mm)	B	C	d	H
SNKJ-016C	6, 10	17	19.6	M12 x 1	4
SNLJ-016B	16	19	21.9	M14 x 1	5
SN-020B	20	26	30	M20 x 1.5	8
SN-032B	25	32	37	M26 x 1.5	8

Material: Carbon steel

Part no.	Applicable bore size (mm)	B	C	D	H
NTJ-010C	6, 10	7	8.1	M4 x 0.7	3.2
NTJ-015C	16	8	9.2	M5 x 0.8	4
NT-02	20	13	15	M8 x 1.25	5
NT-03	25	17	19.6	M10 x 1.25	6

T-bracket

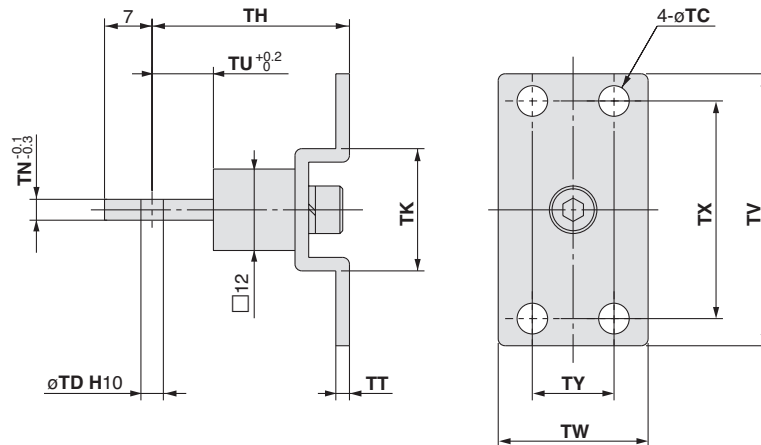

Part no.	Applicable bore size (mm)	TC	TD	TH	TK	TN	TT	TU	TV	TW	TX	TY
CJ-T010C	6, 10	4.5	3.3	29	18	3.1	2	9	40	22	32	12
CJ-T016C	16	5.5	5	35	20	6.4	2.3	14	48	28	38	16

Clevis pin

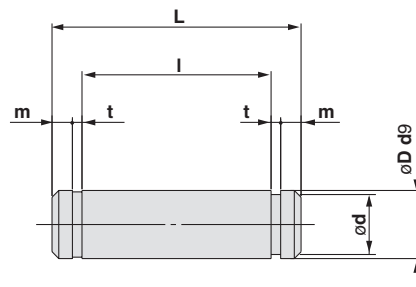

Material: Stainless steel

Part no.	Applicable bore size (mm)	d	D	l	L	m	t
CD-J010	6, 10	3	3.3	12.2	15.2	1.2	0.3
CD-Z015	16	4.8	5	18.3	22.7	1.5	0.7
CDP-1	20,25	8.6	9	19.2	25	1.75	1.15



Series **MQQ/MQM**

Specific Product Precautions 1

Be sure to read this before handling.

Refer to back page 1 through to 3 for Safety Instructions and Actuators Precautions.

Operation

Caution

1. When mounting, thoroughly flush out the connector piping and be sure that dirt and chips, etc., do not get inside the cylinder.
2. Install an air filter with a filtration degree of 5 μ m or less on the air supply. Furthermore, when controlling for low speed or controlled output, use clean air (atmospheric pressure dew point temperature of -10°C). Installation of a mist separator (filtration degree 0.3 μ m or less) is also recommended.
3. Use a metal seal type when using solenoid valves for cylinder actuation. If a rubber seal type is used, there may be an increase in operating resistance due to grease sprayed from the main valve.
4. Operate so that the load applied to the piston rod is normally in the axial direction.
In the event that a lateral load is unavoidable, do not exceed the range of the allowable lateral load at the rod end (refer to pages 19 and 20). (Use outside of the operating limits may cause an adverse effect on the life of the unit through problems such as looseness in the guide unit and a loss of precision.)
5. Take care not to scratch or gouge the sliding portion of the rod. This may cause malfunction or shorten the unit's life.
6. When attaching a work piece to the end of the rod, move the rod to the fully retracted position and use the wrench flats at the end of the rod. Fasten the work piece without applying a large amount of torque to the rod.
7. Be certain to connect a load so that the rod axis is aligned with the load and its direction of movement.
Especially when a cylinder rod is connected directly to a guide function (such as bearings, etc.) on the equipment side, the following is likely to occur. Either an offset load will occur and the sliding resistance will not be stable or galling will occur on the metal seal parts. Therefore, be sure to use a floating joint or a spherical joint.
8. When a piston rod is driven with a circuit from an external force such as force, control, tension control, etc., a stick-slip phenomenon will likely occur and sliding resistance will not be stable if the amount of displacement is 0.05 or less.
9. When it is used in locations where a constant vibration is applied, such as a polishing machine, etc., consult with us.

Disassembly

Caution

1. The component parts of the metal seal cylinder are manufactured to precision tolerances, and therefore cannot be disassembled.

Lubrication

Caution

1. Lubrication of non-lube type cylinder

Do not apply lubrication when controlling for low speed or controlled output. If lubrication is applied, there may be changes in operating resistance due to factors such as the viscosity and surface tension of the oil. Also, use a metal seal type when using solenoid valves for cylinder actuation. If a rubber seal type is used, there may be an increase in operating resistance due to grease sprayed from the main valve.

Lubrication is also unnecessary for high speed actuation, but in the event that lubrication is applied, use turbine oil class 1 (with no additives) ISO VG32. (Do not use spindle oil or machine oil.)



Series MQQ/MQM

Specific Product Precautions 2

Be sure to read this before handling.

Refer to back page 1 through to 3 for Safety Instructions and Actuators Precautions.

Selection

Series MQQ



Operating Speed

Load Weight and Maximum Speed: MQQT/MQQL

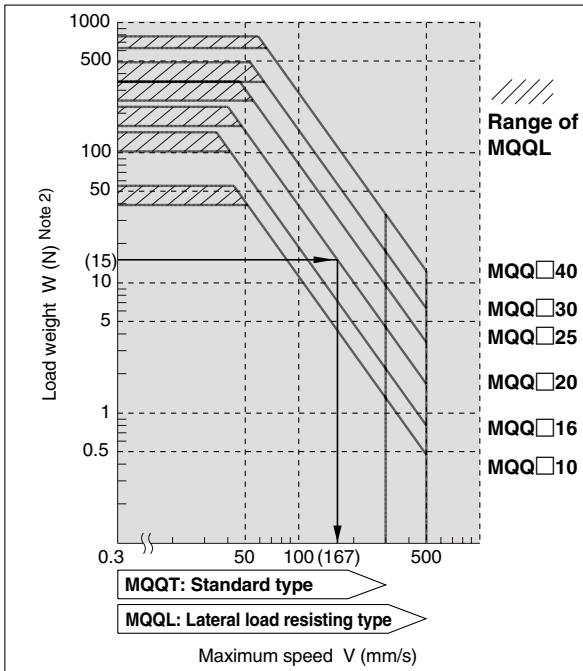

Example)
Driving a load of 15(N) using the MQQ□20 with a maximum speed of 167 (mm/sec)

Lateral load resisting type: MQQ□

Bore size (mm)	Allowable kinetic energy (J)
10	0.006
16	0.010
20	0.022
25	0.044
30	0.080
40	0.160

Note 1) When a load is attached to the rod end, adjust the speed so that the maximum speed is no more than that shown in the graph for the corresponding load weight.

Note 2) The weight of cylinder's moving parts is included in the load weight. (See the graph on the right.)

Moving Parts Weight

MQQ□□ Moving Parts Weight

Bore size (mm)	MQQT□: Moving parts weight (g)	MQQL□: Moving parts weight (g)
10	Weight = 8.9 + {3.1 x (stroke/10)}	Weight = 16.7 + {3.1 x (stroke/10)}
16	Weight = 22.9 + {4.0 x (stroke/10)}	Weight = 34.9 + {4.0 x (stroke/10)}
20	Weight = 34.8 + {6.6 x (stroke/10)}	Weight = 57.9 + {6.6 x (stroke/10)}
25	Weight = 66.9 + {8.8 x (stroke/10)}	Weight = 97.7 + {8.8 x (stroke/10)}
30	Weight = 115.0 + {15.8 x (stroke/10)}	Weight = 190.2 + {15.8 x (stroke/10)}
40	Weight = 182.2 + {15.8 x (stroke/10)}	Weight = 257.4 + {15.8 x (stroke/10)}

Note) For the front flange type, add 10 mm to the stroke length of the MQQ□F

Allowable Lateral Load at Rod End



(Mounting orientation: Horizontal supply pressure: 0.5 MPa IN = 0.102 kgf)

Standard Type: MQQT□B

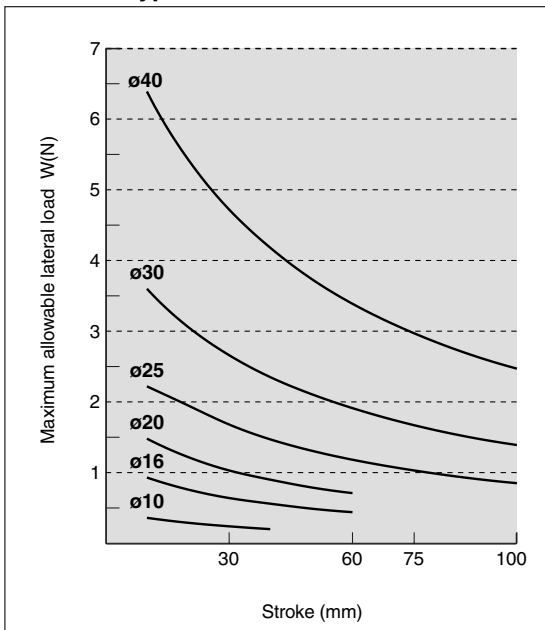

Lateral Load Resisting Type: MQQLB/Built-in Ball Bushing

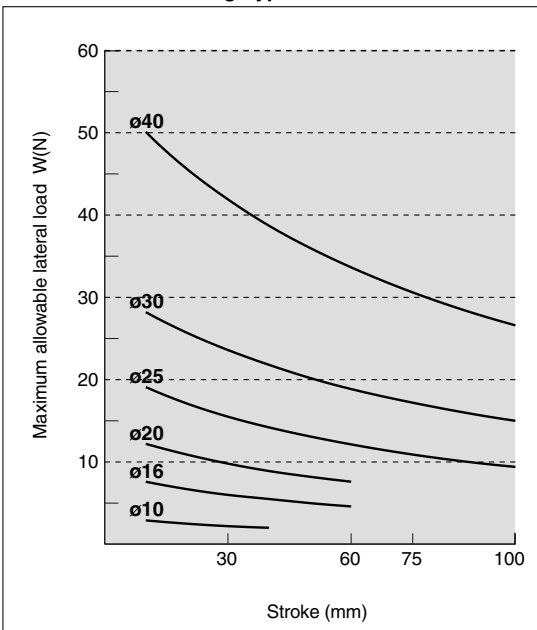

Note 1) The indicated allowable lateral load at the rod end is for the rod end female thread.

Note 2) The allowable lateral load varies depending on the size of a load (the distance to the load's center of gravity). Please contact SMC for further details.



Series MQQ/MQM

Specific Product Precautions 3

Be sure to read this before handling.

Refer to back page 1 through to 3 for Safety Instructions and Actuators Precautions.

Selection

Series MQM

⚠ Caution

Operating Speed

Load Weight and Maximum Speed

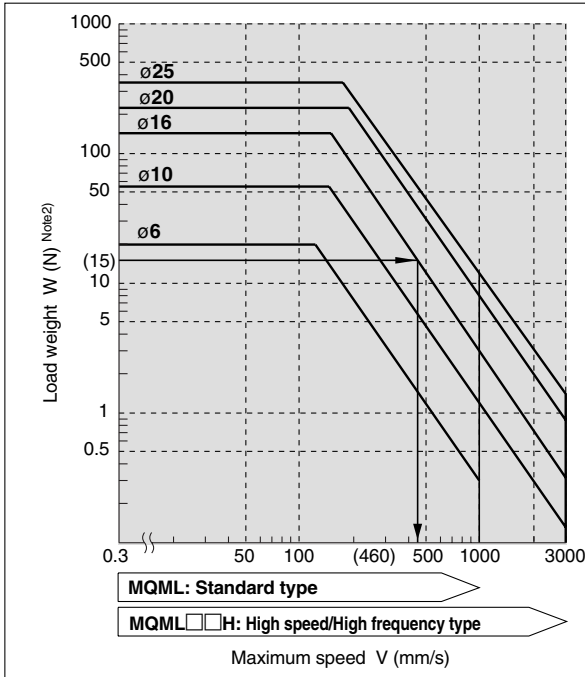

Example)
Driving a load of 15(N) using the MQM16 with a maximum speed of 460 (mm/sec)

Lateral load resisting type: MQML/MQML□□H

Bore size (mm)	Allowable kinetic energy (J)
6	0.015
10	0.059
16	0.161
20	0.386
25	0.597

Note 1) When a load is attached to the rod end, adjust the speed so that the maximum speed is no more than that shown in the graph for the corresponding load weight.

Note 2) The weight of cylinder's moving parts is included in the load weight. (See the graph on the right.)

Moving Parts Weight

MQM Moving Parts Weight

Bore size (mm)	Moving parts weight (g)
6	Weight = 8.2 + {1.6 x (stroke/15)}
10	Weight = 12.0 + {1.6 x (stroke/15)}
16	Weight = 28.6 + {2.2 x (stroke/15)}
20	Weight = 72.0 + {6.4 x (stroke/15)}
25	Weight = 117.6 + {9.2 x (stroke/15)}

Allowable Lateral Load at Rod End

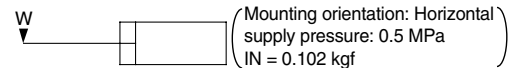

Allowable Lateral Load at Rod End

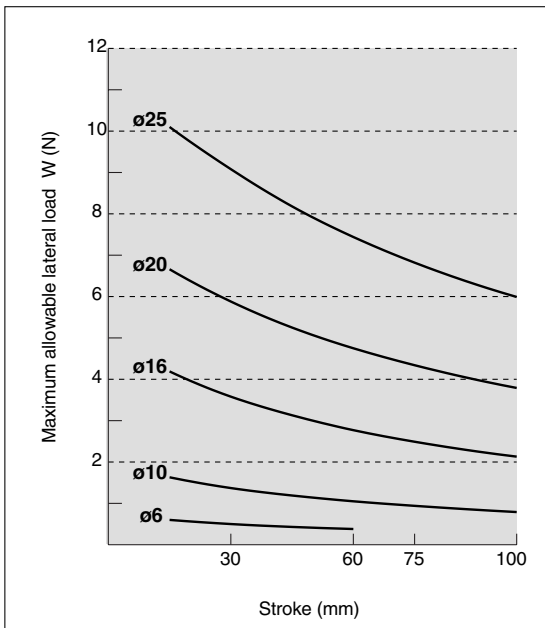

Note 1) The allowable lateral load varies depending on the size of a load (the distance to the load's center of gravity). Please contact SMC for further details.

Low Friction Cylinder (Single Acting)

Series MQP

ø4, ø6, ø10, ø16, ø20

How to Order

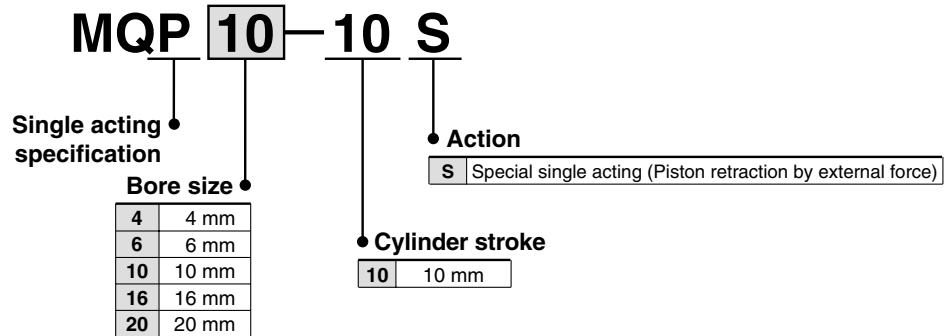

* The MQP series is not auto switch capable.

Specifications

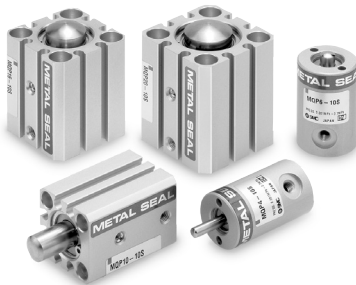

Bore size (mm)		4	6	10	16	20
Seal construction		Metal seal				
Action		Special single acting (Piston retraction by external force)				
Proof pressure		1.05 MPa				
Maximum operating pressure		0.7 MPa				
Minimum operating pressure <small>Note 1)</small>		0.001 MPa				
Ambient and fluid temperature		-5 to +80°C				
Lubrication <small>Note 2)</small>		Not required (Non-lube)				
Stroke length tolerance		+1.0 0				
Total allowable leakage	Supply pressure 0.1 MPa	100 cm ³ /min or less				
	Supply pressure 0.3 MPa	500 cm ³ /min or less				
	Supply pressure 0.5 MPa	1000 cm ³ /min or less				

Note 1) Excluding the weight of moving parts.

Note 2) Refer to precautions on page 22 regarding lubrication.

Moving Parts and Total Weight

Unit: g

Bore size (mm)	Moving parts weight	Total weight
4	4	43
6	8	55
10	24	96
16	62	161
20	103	239

Theoretical Output

Unit: N

Bore size (mm)	Piston area (mm ²)	Operating pressure (MPa)						
		0.1	0.2	0.3	0.4	0.5	0.6	0.7
4	12.6	1.3	2.6	3.9	5.2	6.5	7.8	9.1
6	28.3	2.8	5.6	8.4	11.2	14.0	16.8	19.6
10	78.5	7.9	15.7	23.6	31.4	39.3	47.1	55.0
16	196.1	19.6	39.2	58.9	78.4	98.1	117.7	137.3
20	314.2	31.4	62.8	94.3	125.7	157.1	188.5	219.9

Construction

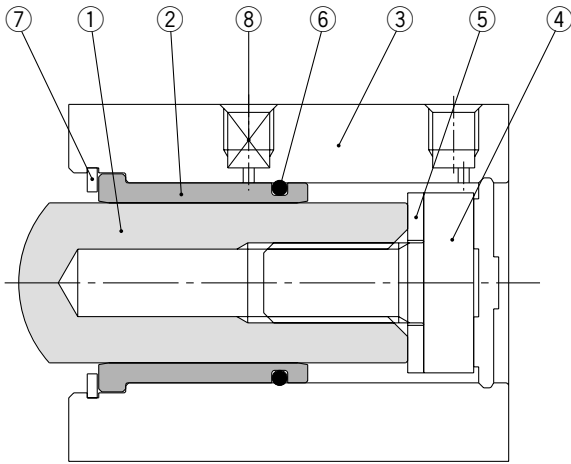

Component Parts

No.	Description	Material	Note
1	Piston rod	Special stainless steel	
2	Liner	Special stainless steel	
3	Cylinder tube	Aluminum alloy	Hard anodized
4	Bolt	Carbon tool steel	
5	Bumper	Fluororesin	
6	O-ring	NBR	
7	Retaining ring	Carbon tool steel	Nickel plated
8	Plug	Carbon tool steel	Nickel plated

Dimensions

ø4, ø6

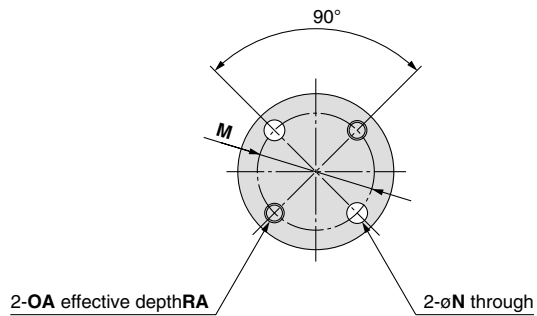
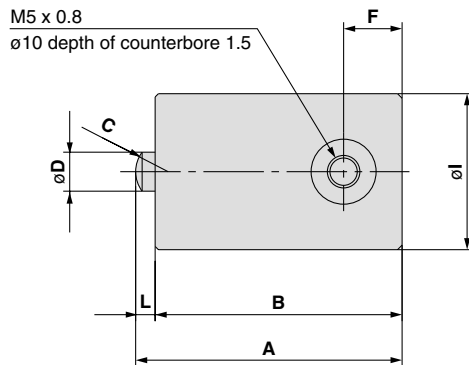

ø10, ø16, ø20

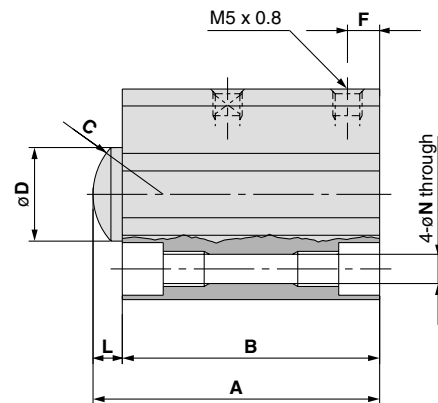
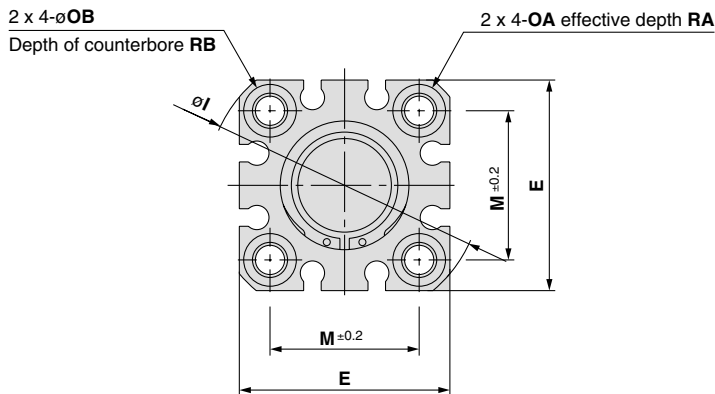

(mm)

Bore size (mm)	A	B	C	D ^{Note)}	E	F	I	L	M	N	OA	OB	RA	RB
4	41	38	SR3	4	—	9	22	3	16	3.2	M3 x 0.5	—	6	—
6	41	38	SR5	6	—	9	24	3	18	3.2	M3 x 0.5	—	6	—
10	46.5	41.5	SR8	10	29	5.5	38	5	20	3.5	M4 x 0.7	6.5	7	4
16	49	44	SR12	16	36	5.5	47	5	25.5	5.4	M6 x 1.0	9	10	7
20	52.5	47.5	SR15	20(19)	40	5.5	52	5	28	5.4	M6 x 1.0	9	10	7

Note) Figures in () are the diameter in the rod end part.



Series MQP

Specific Product Precautions

Be sure to read this before handling.

Refer to back page 1 through to 3 for Safety Instructions and Actuators Precautions.

Operation

⚠ Caution

1. When mounting, thoroughly flush out the connector piping and be sure that dirt and chips, etc., do not get inside the cylinder.
2. Install an air filter with a nominal filtration degree of 5 μm or less on the air supply. Furthermore, when controlling for low speed or controlled output, use clean air (atmospheric pressure dew point temperature of -10°C or less). Installation of a mist separator (nominal filtration degree 0.3 μm or less) is also recommended.
3. Use a metal seal type when using solenoid valves for cylinder actuation. If a rubber seal type is used, there may be an increase in operating resistance due to grease sprayed from the main valve.
4. This cylinder cannot be used at the end of its stroke. Use it with an intermediate stroke of 10 mm.
5. The rod end should not come in direct contact with an equipment or workpiece. Also, make sure that the opposite side of the rod end is flat to make point-contact with the spherical surface of the rod end.

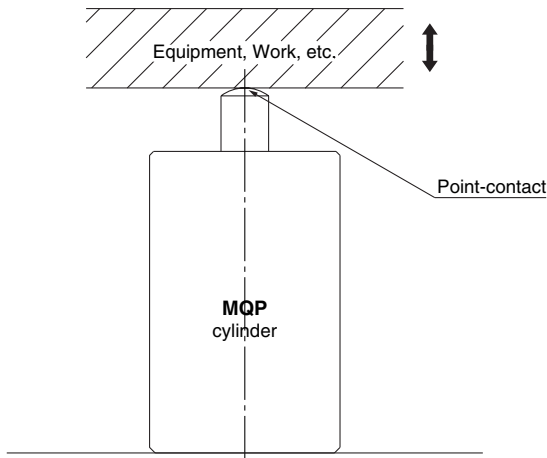

The material of the cylinder rod is heat-treated stainless steel (HRC60). The roughness of the spherical contact of the attaching part (Equipment, Work, etc) should be Rz6.3 and the material should be HB100 or greater (Aluminum material: 2000 line or 7000 line or equivalent) When higher precision or longer service life is required, we recommend using a heat-treated material + flat polished machined material (Rz0.8)

Also, although applying grease on the spherical contact parts will make the operation more smooth and reduce the abrasion, use caution to prevent any grease from being applied to the cylinder's sliding surface.

Operation

6. When connecting, be sure to align the rod axis with the load and the direction of movement.

The allowable angle of the cylinder's mounting surface in an equipment should be 3° or less.

(1° or less is recommended.) When not properly aligned, a lateral load will likely be applied to the rod and the spherical surface will likely skid. This will result in a reduction or dispersion of thrust and likely a malfunction.

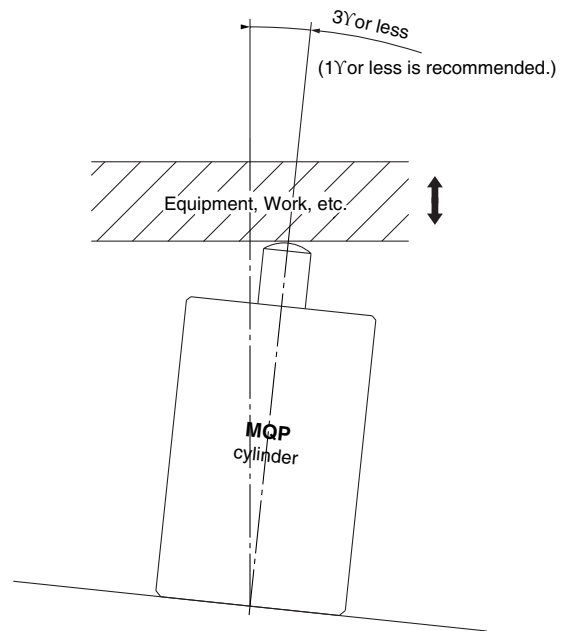

Disassembly

⚠ Caution

1. The component parts of the metal seal cylinder are manufactured to precision tolerances, and therefore cannot be disassembled.

Lubrication

⚠ Caution

1. Lubrication of non-lube type cylinder

Do not apply lubrication when controlling for low speed or controlled output. If lubrication is applied, there may be changes in operating resistance due to factors such as the viscosity and surface tension of the oil. Also, use a metal seal type when using solenoid valves for cylinder actuation. If a rubber seal type is used, there may be an increase in operating resistance due to grease sprayed from the main valve.

Lubrication is also unnecessary for high speed actuation, but in the event that lubrication is applied, use turbine oil class 1 (with no additives) ISO VG32. (Do not use spindle oil or machine oil.)



Actuators Precautions 1

Be sure to read this before handling.

Caution on Design

Warning

- 1. There is a possibility of dangerous sudden action by air cylinders if sliding parts of machinery are twisted due to external forces, etc.**

In such cases, human injury may occur; e.g., by catching hands or feet in the machinery, or damage to the machinery itself may occur. Therefore, the machine should be adjusted to operate smoothly and designed to avoid such dangers.

- 2. A protective cover is recommended to minimize the risk of personal injury.**

If a stationary object and moving parts of a cylinder are in close proximity, personal injury may occur. Design the structure to avoid contact with the human body.

- 3. Securely tighten all stationary parts and connected parts so that they will not become loose.**

Especially when a cylinder operates with high frequency or is installed where there is a lot of vibration, ensure that all parts remain secure.

- 4. A deceleration circuit or shock absorber may be required.**

When a driven object is operated at high speed or the load is heavy, a cylinder's cushion will not be sufficient to absorb the impact. Install a deceleration circuit to reduce the speed before cushioning, or install an external shock absorber to relieve the impact. In this case, the rigidity of the machinery should also be examined.

- 5. Consider a possible drop in circuit pressure due to a power outage, etc.**

When a cylinder is used in a clamping mechanism, there is a danger of workpieces dropping if there is a decrease in clamping force due to a drop in circuit pressure caused by a power outage, etc. Therefore, safety equipment should be installed to prevent damage to machinery and human injury. Suspension mechanisms and lifting devices also require consideration for drop prevention.

- 6. Consider a possible loss of power source.**

Measures should be taken to protect against bodily injury and equipment damage in the event that there is a loss of power to equipment controlled by pneumatics, electricity, or hydraulics.

- 7. Design circuitry to prevent sudden lurching of driven objects.**

When a cylinder is driven by an exhaust center type directional control valve or when starting up after residual pressure is exhausted from the circuit, etc., the piston and its driven object will lurch at high speed if pressure is applied to one side of the cylinder because of the absence of air pressure inside the cylinder. Therefore, equipment should be selected and circuits designed to prevent sudden lurching, because there is a danger of human injury and/or damage to equipment when this occurs.

- 8. Consider emergency stops.**

Design so that human injury and/or damage to machinery and equipment will not be caused when machinery is stopped by a safety device under abnormal conditions, a power outage or a manual emergency stop.

- 9. Consider the action when operation is restarted after an emergency stop or abnormal stop.**

Design the machinery so that human injury or equipment damage will not occur upon restart of operation.

When the cylinder has to be reset at the starting position, install manual safety equipment.

Selection

Warning

- 1. Confirm the specifications.**

The products featured in this catalog are designed for use in industrial compressed air systems. If the products are used in conditions where pressure and/or temperature are outside the range of specifications, damage and/or malfunctions may occur. Do not use in these conditions. (Refer to the specifications.)

Please consult with SMC if you use a fluid other than compressed air.

- 2. Intermediate stops**

When intermediate stopping of the cylinder piston is performed by a 3 position closed center type directional control valve, it is not possible to maintain the stop position for an extended time due to the construction of the metal seal cylinder.

Caution

- 1. Operate the piston within a range such that collision damage will not occur at the stroke end.**

- 2. When controlling cylinder output, do not create a restricting circuit by using a speed controller, etc. Pressure inside the cylinder will drop and control will become impossible. Be sure to control actuation through pressure control.**

Mounting

Caution

- 1. Be certain to match the rod shaft center with the direction of the load and movement when connecting.**

When not properly matched, problems may arise with the rod and tube, and damage may be caused due to friction on areas such as the inner tube surface, bushings, rod surface and seals.

- 2. When an external guide is used, connect the rod end and the load in such a way that there is no interference at any point within the stroke.**

- 3. Do not scratch or gouge the sliding parts of the cylinder tube or tube rod, etc., by striking or grasping them with other objects.**

Cylinder bores are manufactured to precise tolerances, so that even a slight deformation may cause malfunction. Also, scratches or gouges, etc., in the tube rod may lead to damaged seals and cause air leakage.

- 4. Prevent the seizure of rotating parts.**

Prevent the seizure of rotating parts (pins, etc.) by applying grease.



Actuators Precautions 2

Be sure to read this before handling.

Mounting

⚠ Caution

5. Do not use until you verify that the equipment can operate properly.

After mounting, repairs, or modification, etc., connect the air supply and electric power, and then confirm proper mounting by means of appropriate function and leak tests.

6. Instruction manual

Install the products and operate them only after reading the instruction manual carefully and understanding its contents. Also keep the manual where it can be referred to as necessary.

Piping

⚠ Caution

1. Preparation before piping

Before piping is connected, it should be thoroughly blown out with air (flushing) or washed to remove chips, cutting oil and other debris from inside the pipe.

2. Wrapping of pipe tape

When screwing in pipes and fittings, etc., be certain that chips from the pipe threads and sealing material will not ingress inside the piping.

Also, when pipe tape is used, leave 1.5 to 2 thread ridges exposed at the end of the threads.

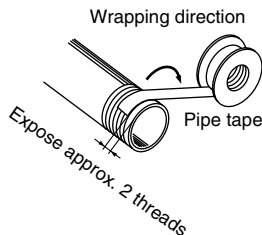

Lubrication

⚠ Caution

1. Lubrication of non-lube type cylinder

Do not apply lubrication when controlling for low speed or controlled output. If lubrication is applied, there may be changes in operating resistance due to factors such as the viscosity and surface tension of the oil. Also, use a metal seal type when using solenoid valves for cylinder actuation. If a rubber seal type is used, there may be an increase in operating resistance due to grease sprayed from the main valve.

Lubrication is also unnecessary for high speed actuation, but in the event that lubrication is applied, use turbine oil class 1 (with no additives) ISO VG32. (Do not use spindle oil or machine oil.)

Air Supply

⚠ Warning

1. Use clean air.

Do not use compressed air which contains chemicals, synthetic oils containing organic solvents, salts or corrosive gases, etc., as this can cause damage or malfunction.

Air Supply

⚠ Caution

1. Install air filters.

Install air filters near valves on their upstream side. The nominal filtration degree should be 5 μ m or less. Furthermore, when controlling for low speed or controlled output, use clean air (atmospheric pressure dew point temperature of -10°C or less). Installation of mist separator AM series (nominal filtration degree 0.3 μ m or less) or AM + AMD series (nominal filtration degree 0.01 μ m or less) is also recommended.

2. Install an aftercooler, air dryer, or water separator.

Air that includes excessive drainage may cause malfunction of valves and other pneumatic equipment. To prevent this, install an air dryer, aftercooler or water separator, etc.

3. Use the product within the specified range of fluid and ambient temperature.

Take measures to prevent freezing when below 5°C , since moisture in circuits can freeze and cause damage to seals and lead to malfunctions.

For compressed air quality, refer to "Best Pneumatics 2004 Vol.14" catalog.

Operating Environment

⚠ Warning

1. Do not use in atmospheres or locations where corrosion hazards exist.
2. In dusty locations or where water or oil, etc., splash on the equipment, take suitable measures to protect the rod.

Maintenance

⚠ Warning

1. Perform maintenance procedures as shown in the instruction manual.

If it is handled improperly, malfunction or damage of machinery or equipment may occur.

2. Removal of equipment, and supply/exhaust of compressed air

Before any machinery or equipment is removed, first ensure that the appropriate measures are in place to prevent the fall or erratic movement of driven objects and equipment, then cut off the electric power and reduce the pressure in the system to zero. Only then should you proceed with the removal of any machinery and equipment.

When machinery is restarted, proceed with caution after confirming that appropriate measures are in place to prevent cylinders from sudden movement.



⚠ Caution

1. Drain flushing

Remove drainage from air filters regularly. (Refer to the specifications.)

Safety Instructions

These safety instructions are intended to prevent hazardous situations and/or equipment damage. These instructions indicate the level of potential hazard with the labels of “Caution,” “Warning” or “Danger.” They are all important notes for safety and must be followed in addition to International Standards (ISO/IEC) ¹⁾, and other safety regulations.

-  **Danger:** **Danger** indicates a hazard with a high level of risk which, if not avoided, will result in death or serious injury.
-  **Warning:** **Warning** indicates a hazard with a medium level of risk which, if not avoided, could result in death or serious injury.
-  **Caution:** **Caution** indicates a hazard with a low level of risk which, if not avoided, could result in minor or moderate injury.

- 1) ISO 4414: Pneumatic fluid power – General rules and safety requirements for systems and their components.
- ISO 4413: Hydraulic fluid power – General rules and safety requirements for systems and their components.
- IEC 60204-1: Safety of machinery – Electrical equipment of machines. (Part 1: General requirements)
- ISO 10218-1: Robots and robotic devices - Safety requirements for industrial robots - Part 1: Robots.
- etc.

Warning

1. The compatibility of the product is the responsibility of the person who designs the equipment or decides its specifications.

Since the product specified here is used under various operating conditions, its compatibility with specific equipment must be decided by the person who designs the equipment or decides its specifications based on necessary analysis and test results. The expected performance and safety assurance of the equipment will be the responsibility of the person who has determined its compatibility with the product. This person should also continuously review all specifications of the product referring to its latest catalogue information, with a view to giving due consideration to any possibility of equipment failure when configuring the equipment.

2. Only personnel with appropriate training should operate machinery and equipment.

The product specified here may become unsafe if handled incorrectly. The assembly, operation and maintenance of machines or equipment including our products must be performed by an operator who is appropriately trained and experienced.

3. Do not service or attempt to remove product and machinery/equipment until safety is confirmed.

1. The inspection and maintenance of machinery/equipment should only be performed after measures to prevent falling or runaway of the driven objects have been confirmed.
2. When the product is to be removed, confirm that the safety measures as mentioned above are implemented and the power from any appropriate source is cut, and read and understand the specific product precautions of all relevant products carefully.
3. Before machinery/equipment is restarted, take measures to prevent unexpected operation and malfunction.

4. SMC products cannot be used beyond their specifications. They are not developed, designed, and manufactured to be used under the following conditions or environments. Use under such conditions or environments is not allowed.

1. Conditions and environments outside of the given specifications, or use outdoors or in a place exposed to direct sunlight.
2. Use for nuclear power, railways, aviation, space equipment, ships, vehicles, military application, equipment affecting human life, body, and property, combustion equipment, entertainment equipment, emergency shut-off circuits, press clutches, brake circuits, safety equipment, etc., and use for applications that do not conform to standard specifications such as catalogues and operation manuals.
3. Use for interlock circuits, except for use with double interlock such as installing a mechanical protection function in case of failure. Please periodically inspect the product to confirm that the product is operating properly.

Caution

SMC develops, designs, and manufactures products to be used for automatic control equipment, and provides them for peaceful use in manufacturing industries. Use in non-manufacturing industries is not allowed.

Products SMC manufactures and sells cannot be used for the purpose of transactions or certification specified in the Measurement Act of each country.

The new Measurement Act prohibits use of any unit other than SI units in Japan.

Limited warranty and Disclaimer/Compliance Requirements

The product used is subject to the following “Limited warranty and Disclaimer” and “Compliance Requirements”. Read and accept them before using the product.

Limited warranty and Disclaimer

1. The warranty period of the product is 1 year in service or 1.5 years after the product is delivered, whichever is first. ²⁾ Also, the product may have specified durability, running distance or replacement parts. Please consult your nearest sales branch.
2. For any failure or damage reported within the warranty period which is clearly our responsibility, a replacement product or necessary parts will be provided. This limited warranty applies only to our product independently, and not to any other damage incurred due to the failure of the product.
3. Prior to using SMC products, please read and understand the warranty terms and disclaimers noted in the specified catalogue for the particular products.
 - 2) **Suction cups (Vacuum pads) are excluded from this 1 year warranty.**

A suction cup (vacuum pad) is a consumable part, so it is warranted for a year after it is delivered. Also, even within the warranty period, the wear of a product due to the use of the suction cup (vacuum pad) or failure due to the deterioration of rubber material are not allowed by the limited warranty.

Compliance Requirements

1. The use of SMC products with production equipment for the manufacture of weapons of mass destruction (WMD) or any other weapon is strictly prohibited.
2. The exports of SMC products or technology from one country to another are governed by the relevant security laws and regulations of the countries involved in the transaction. Prior to the shipment of a SMC product to another country, assure that all local rules governing that export are known and followed.

Safety Instructions

Be sure to read the “Handling Precautions for SMC Products” (M-E03-3) and “Operation Manual” before use.

SMC Corporation (Europe)

Austria	+43 (0)2262622800	www.smc.at	office.at@smc.com
Belgium	+32 (0)33551464	www.smc.be	info@smc.be
Bulgaria	+359 (0)2807670	www.smc.bg	sales.bg@smc.com
Croatia	+385 (0)13707288	www.smc.hr	sales.hr@smc.com
Czech Republic	+420 541424611	www.smc.cz	office.at@smc.com
Denmark	+45 70252900	www.smc.dk	smc.dk@smc.com
Estonia	+372 651 0370	www.smc.ee	info.ee@smc.com
Finland	+358 207513513	www.smc.fi	smc.fi@smc.com
France	+33 (0)164761000	www.smc-france.fr	supportclient.fr@smc.com
Germany	+49 (0)61034020	www.smc.de	info.de@smc.com
Greece	+30 210 2717265	www.smcHELLAS.gr	sales@smcHELLAS.gr
Hungary	+36 23513000	www.smc.hu	office.hu@smc.com
Ireland	+353 (0)14039000	www.smcautomation.ie	technical.ie@smc.com
Italy	+39 03990691	www.smcitalia.it	mailbox.it@smc.com
Latvia	+371 67817700	www.smc.lv	info.lv@smc.com

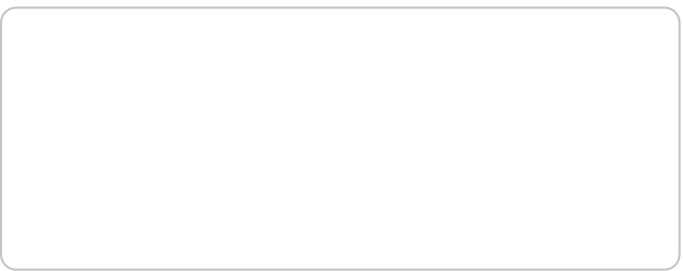

Lithuania	+370 5 2308118	www.smclt.lt	info.lt@smc.com
Netherlands	+31 (0)205318888	www.smc.nl	info@smc.nl
Norway	+47 67129020	www.smc-norge.no	post.no@smc.com
Poland	+48 22 344 40 00	www.smc.pl	office.pl@smc.com
Portugal	+351 214724500	www.smc.eu	apoiocliente.pt@smc.com
Romania	+40 213205111	www.smcromania.ro	office.ro@smc.com
Russia	+7 (812)3036600	www.smc.eu	sales@smcru.com
Slovakia	+421 (0)413213212	www.smc.sk	sales.sk@smc.com
Slovenia	+386 (0)73885412	www.smc.si	office.si@smc.com
Spain	+34 945184100	www.smc.eu	post.es@smc.com
Sweden	+46 (0)86031240	www.smc.nu	order.se@smc.com
Switzerland	+41 (0)523963131	www.smc.ch	helpcenter.ch@smc.com
Turkey	+90 212 489 0 440	www.smcturkey.com.tr	satis.tr@smc.com
UK	+44 (0)845 121 5122	www.smc.uk	sales.gb@smc.com
South Africa	+27 10 900 1233	www.smcza.co.za	Sales.za@smc.com