

Miniature One-touch Fittings

One-touch Mini

Series KJ



Applicable Tubing: $\varnothing 3.2$, $\varnothing 4$, $\varnothing 6$
 Connection Thread: M3, M5, R 1/8

Guide 1

Guide 2

Chuck
 Suitable for use with nylon, soft nylon and urethane.
 Large retaining force.
 Has large retaining force.

Seal
 Can be used for a wide range of pressures from a low vacuum up to a pressure of 1.0 MPa
 The use of a special profile ensures sealing and reduces resistance when the tube is inserted.

Gasket

Release button (Light gray)
Light force for removal
 When the fitting is removed from the tubing, the chuck and collet are released, thus preventing them from biting into the tube to an unnecessary degree. Unique shape allows easy tube release.

Tube

Body (White)

O-ring

Stud
Effective when piping in a confined space.

- The body and the threaded portion can rotate (for positioning to some extent).
- Stud is electroless nickel plated.
- Standard with preapplied thread seal 1/8

PAT.PEND

- K
- M
- H
- D
- MS
- T
- VMG

Optimum piping in less space with 20% reduction of the outside diameter

Thread seal is standard.

Copper-free specifications (With electroless nickel plated.)

Possible to use in vacuum to -100 kPa



Applicable Tubing

Tubing material	Nylon, Soft nylon, Polyurethane
Tubing O.D.	$\varnothing 3.2$, $\varnothing 4$, $\varnothing 6$











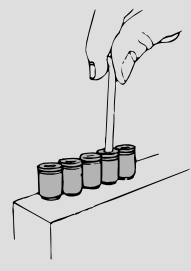

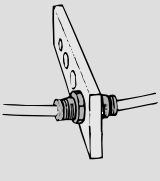

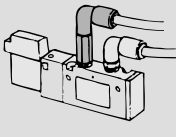







Specifications

Fluid	Air/Water ^{Note}	
Maximum operating pressure	1.0 MPa	
Operating vacuum pressure	-100 kPa	
Proof pressure	3.0 MPa	
Ambient and fluid temperature	-5 to 60°C, Water: 0 to 40°C (No freezing)	
Thread	Mounting section	JIS B 0203 (Taper thread for piping) JIS B 0209, Class 2 (Metric coarse thread)
	Nut section	JIS B 0211 Class 2 (Metric fine thread)
Thread seal (Standard)	With thread seal	
Copper-free (Standard)	Brass parts are all electroless nickel plated.	

Note) Applicable for general industrial water. Please consult with SMC if using for other kinds of fluid. Also, the surge pressure must be under the maximum operating pressure.

Principal Parts Material

Body	Stainless steel 303, C3604BD, PBT
Stud	C3604BD (Thread portion)
Chuck, Guide 2	Stainless steel 304
Release button, Guide 1	POM
Seal, O-ring	NBR
Gasket	Stainless steel 304, NBR

Model					
Hex. socket head male connector KJS	P. 4		Internal hex. allows thread connection by using an allen wrench for confined spaces.		
Bulkhead union KJE	P. 9		Use to connect tubes through a panel.		
Extended male elbow KJW	P. 6		Universal male elbow allows thread connection by using a socket wrench for confined spaces.		
Male connector KJH	P. 4		Use to pipe in the same direction from female thread. Most general style.		
Female connector KJF	P. 4		Use to pipe from male thread such as pressure gauge.		
Straight union KJH	P. 4		Use to connect tubes in the same direction.		
Different diameter straight KJH	P. 5		Use to connect different sized tubes.		
Male elbow KJL	P. 5		Use to pipe at right angles to female thread. Most general style.		
Union elbow KJL	P. 5		Use to connect tubes at right angles.		
Plug-in elbow KJL	P. 5		Use to change by 90° in a tube fetching direction from One-touch fittings.		
Reducer elbow KJL	P. 6		Use to change by 90° in a tube fetching direction from One-touch fittings and to size down.		
Male branch tee KJT	P. 6		Use to branch line from female thread in both 90° directions.		
Union tee KJT	P. 7		Use to connect tubes in both 90° directions.		
Different diameter tee KJT	P. 7		Use to connect tubes with size down in both 90° directions.		
Male run tee KJY	P. 7		Use to branch line in the same direction from female thread and in 90° direction.		
Union "Y" KJU	P. 8		Use to branch line in the same direction.		
Different dia. union "Y" KJU	P. 8		Use to branch line with size down in the same direction.		
Plug-in "Y" KJU	P. 8		Use to branch line in the same direction from One-touch fittings.		
Different diameter plug-in "Y" KJX	P. 8		Use to branch line with size down in the same direction from One-touch fittings.		
Branch "Y" KJU	P. 9		Use to branch line in the same direction from female thread.		
Plug-in reducer KJR	P. 9		Use to change size of One-touch fittings.		

- K□
- M□
- H□
- D□
- MS
- T□
- VMG

Gasket/Seal for M5 thread
Part no.: M-5G2
Material: Stainless steel 304, NBR

⚠ Precautions

Be sure to read before handling.
Refer to pages 15-18-3 to 15-18-4 for Safety Instructions and Common Precautions on the products mentioned in this catalog, and refer to pages 15-1-10 to 15-1-11 for Precautions on every series.

Interchangeability of Series KJ and KQ

⚠ Caution

- Do not use the plug-in KQ Series with the KJ Series, it will not hold.
- For combinations other than the plug-in KQs, they are interchangeable.

Installation and Removal of One-touch Mini Fittings

⚠ Caution

Installing of tube

- Cut the tube perpendicularly, using caution not to damage its surface. (Use tube cutter TK-1, 2 or 3. Do not cut the tube with cutting pliers, nippers, scissors, etc.)
- Grasp the tube, then slowly push it until it comes to a stop.
- Then, pull it back gently to make sure that it does not come out.

Removing of tube

(Use one hand for removal.)

- Hold the release button with the thumb and forefinger.
- Grasp the tube with the remaining three fingers and palm.
- Then, pull out the tube with three fingers and palm while pushing in the release button with the thumb and the forefinger.
- To reuse the released tube, cut off the damaged portion of the tube.

Series KJ

Male Connector: KJH

<M3, M5>	Applicable tubing O.D. (mm)	Connection thread T	Model	H (width across flats)	L	A	M	Effective area (mm ²)		Weight (g)
								Nylon	Urethane	
	3.2	M3 x 0.5	KJH23-M3	7	16.3	13.7	12.7	0.9	0.9	1.6
		M5 x 0.8	KJH23-M5		16.7	13.6		2		
		R 1/8	KJH23-01S	10	13.8	9.8*	3	2.5	4.7	
<R 1/8>	4	M3 x 0.5	KJH04-M3	8	16.3	13.7	12.7	0.9	0.9	1.9
		M5 x 0.8	KJH04-M5		17	13.9		2.4		
		R 1/8	KJH04-01S	10	14.8	10.8*	4	4	4.6	
	6	M5 x 0.8	KJH06-M5	10	17.8	14.7	13.5	4	4	3.3
		R 1/8	KJH06-01S		19.4	15.4*		10	10	5.2

* Reference dimensions after R thread installation.

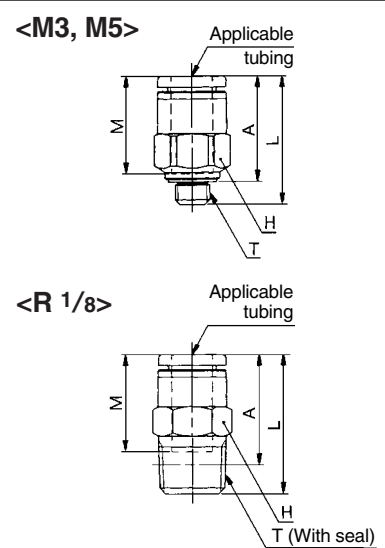

Hexagon Socket Head Male Connector: KJS

<M3, M5>	Applicable tubing O.D. (mm)	Connection thread T	Model	H (width across flats)	Note) ϕD	L	A	M	Effective area (mm ²)		Weight (g)
									Nylon	Urethane	
	3.2	M3 x 0.5	KJS23-M3	1.5	7	16.3	13.7	12.7	1.4	1.4	1.3
		M5 x 0.8	KJS23-M5	2		19.7	16.6		2.5	2.5	2.8
<R 1/8>	4	M3 x 0.5	KJS04-M3	1.5	8	16.3	13.7	12.7	1.4	1.4	1.6
		M5 x 0.8	KJS04-M5	2.5		18.7	15.6		4	4	2.7
		R 1/8	KJS04-01S	3	9.8	19.7	15.7*	4	4	5.4	
	6	M5 x 0.8	KJS06-M5	2.5	10	19.5	16.4	13.5	4	4	3.3
		R 1/8	KJS06-01S	4		20	16*		10	10	5.2

* Reference dimensions after R thread installation. Note) ϕD : Max. diameter

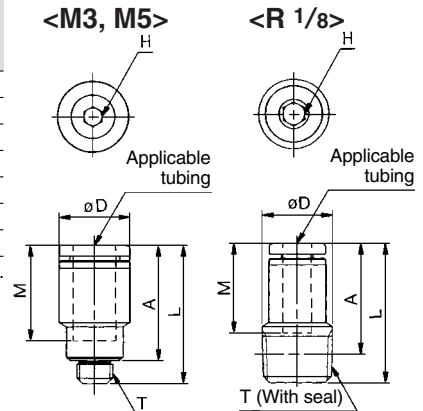

Female Connector: KJF

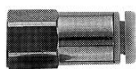
	Applicable tubing O.D. (mm)	Connection thread T	Model	H (width across flats)	Note) ϕD	L1	L2	M	Effective area (mm ²)		Weight (g)
									Nylon	Urethane	
	3.2	M3 x 0.5	KJF23-M3	7	7	16.5	6.8	12.7	3	2.5	2.6
		M5 x 0.8	KJF23-M5			18.8	7.9		2.8		
	4	M3 x 0.5	KJF04-M3	8	8	16.1	6.4	12.7	4	4	3.2
		M5 x 0.8	KJF04-M5			18.7	7.8		3.8		
	6	M5 x 0.8	KJF06-M5	10	10	18	7.5	13.5	10	10	5.3

Note) ϕD : Max. diameter

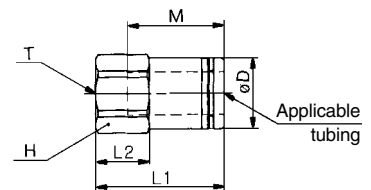

Straight Union: KJH

	Applicable tubing O.D. (mm)	Model	Note) ϕD	L	M	Effective area (mm ²)		Weight (g)
						Nylon	Urethane	
	3.2	KJH23-00	8.4	26.3	12.7	3	2.5	1.4
	4	KJH04-00	9.3	26.3	12.7	4	4	1.7
	6	KJH06-00	11.6	28	13.5	10	10	2.5

Note) ϕD : Max. diameter

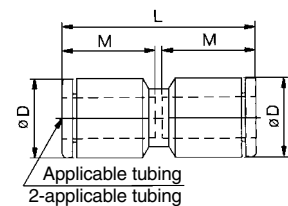

Different Diameter Straight: KJH



Applicable tubing O.D. (mm)		Model	Note) $\phi D1$	Note) $\phi D2$	L	M1	M2	Effective area (mm ²)		Weight (g)
(a)	(b)							Nylon	Urethane	
3.2	4	KJH23-04	8.4	9.3	26.3	12.7	12.7	3	2.5	1.6
	6	KJH23-06		11.6			27.2			13.5
4	6	KJH04-06	9.3	11.6	27.2	12.7	13.5	4	4	2.2

Note) $\phi D1, \phi D2$: Max. diameter

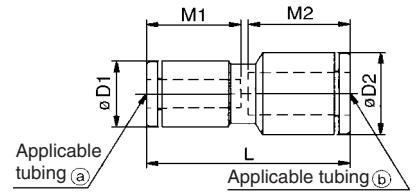

Male Elbow: KJL

<M3, M5>



<R 1/8>



Applicable tubing O.D. (mm)	Connection threads T	Model	H (width across flats)	Note) ϕD	L1	L2	A	M	Effective area (mm ²)		Weight (g)			
									Nylon	Urethane				
3.2	M3 x 0.5	KJL23-M3	7	8.4	15.3	12.5	14.1	12.7	0.8	0.8	2.1			
	M5 x 0.8	KJL23-M5							13.2	14.3	2.5			
	R 1/8	KJL23-01S							15.2	15.4*	6.7			
4	M3 x 0.5	KJL04-M3	7	9.3	15.6	13	15.1	12.7	0.8	0.8	2.2			
	M5 x 0.8	KJL04-M5							13.7	15.3	2.7			
	R 1/8	KJL04-01S							15.7	16.4*	6.8			
6	M5 x 0.8	KJL06-M5	7	11.6	16.1	14.7	17.4	13.5	3.5	3.5	3.2			
	R 1/8	KJL06-01S							17.8	16.7	18.5*	9	9	6.4

* Reference dimensions after R thread installation.
Note) ϕD : Max. diameter

<M3, M5>

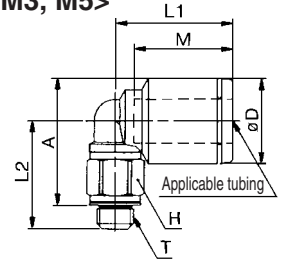

<R 1/8>

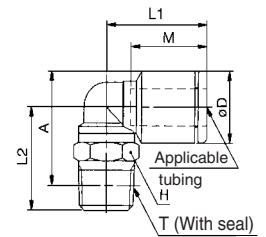

Union Elbow: KJL



Applicable tubing O.D. (mm)	Model	Note) ϕD	L	Q	M	Effective area (mm ²)		Weight (g)
						Nylon	Urethane	
3.2	KJL23-00	8.4	15	5.8	12.7	2.6	2.2	1.6
4	KJL04-00	9.3	15.8	6.3	12.7	3.5	3.5	2
6	KJL06-00	11.6	17.1	7.3	13.5	9	9	3.1

Note) ϕD : Max. diameter

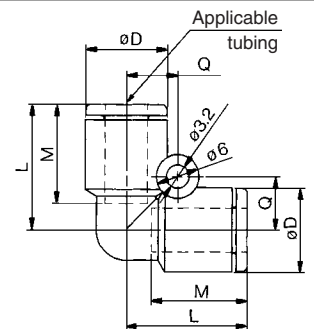

Plug-in Elbow: KJL



Applicable tubing O.D. (mm)	Applicable fitting size ϕd	Model	Note) $\phi D1$	$\phi D2$	L1	L2	A	M	Effective area (mm ²)		Weight (g)
									Nylon	Urethane	
3.2	3.2	KJL23-99	8.4	6	14.5	23.8	15.3	12.7	2.6	2.2	1
4	4	KJL04-99	9.3	6	15.6	24.7	16.7	12.7	3.5	3.5	1.2
6	6	KJL06-99	11.6	7	16.3	26.8	19.1	13.5	9	9	2

Note) $\phi D1$: Max. diameter

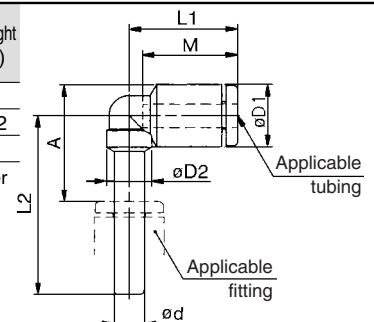

Series KJ

Reducer Elbow: KJL



Applicable tubing O.D. (mm)	Applicable fitting size ϕd	Model	(Note) $\phi D1$	$\phi D2$	L1	L2	A	M	Effective area (mm ²)		Weight (g)
									Nylon	Urethane	
3.2	4	KJL23-04	8.4	6	14.5	24.3	15.8	12.7	2.6	2.2	1.1
	6	KJL23-06				25.3	16				1.2
4	6	KJL04-06	9.3	6	15.6	25.7	16.9	12.7	3.5	3.5	1.4

Note) $\phi D1$: Max. diameter

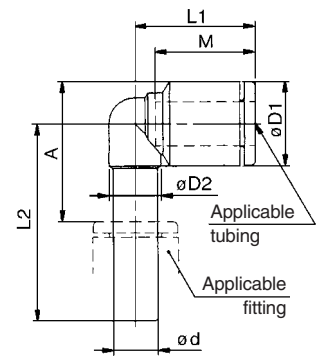

Extended Male Elbow: KJW

<M3, M5>



<R 1/8>



Applicable tubing O.D. (mm)	Connection thread T	Model	H (width across flats)	(Note) ϕD	L1	L2	A	M	Effective area (mm ²)		Weight (g)
									Nylon	Urethane	
3.2	M3 x 0.5	KJW23-M3	7	8.4	15.3	22.5	24.1	12.7	0.8	0.8	5
	M5 x 0.8	KJW23-M5	10			25.2	26.3				6.2
	R 1/8	KJW23-01S	10			25.4*	25.4*				13.4
4	M3 x 0.5	KJW04-M3	7	9.3	15.6	23	25.1	12.7	0.8	0.8	5.1
	M5 x 0.8	KJW04-M5	10			25.7	27.3				6.4
	R 1/8	KJW04-01S	10			26.4*	26.4*				13.6
6	M5 x 0.8	KJW06-M5	7	11.6	16.1	26.7	29.4	13.5	3.5	3.5	6.9
	R 1/8	KJW06-01S	10			17.8	28.7				30.5*

* Reference dimensions after R thread installation.
Note) ϕD : Max. diameter

<M3, M5>

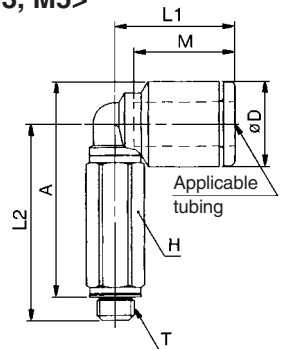

<R 1/8>

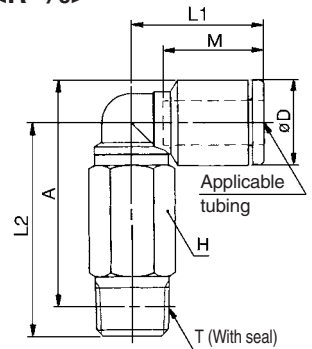

Male Branch Tee: KJT

<M3, M5>



<R 1/8>

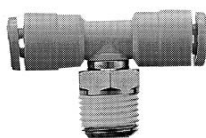

Applicable tubing O.D. (mm)	Connection thread T	Model	H (width across flats)	(Note) ϕD	L1	L2	A	M	Effective area (mm ²)		Weight (g)
									Nylon	Urethane	
3.2	M3 x 0.5	KJT23-M3	7	8.4	15.3	12.5	14.1	12.7	0.9	0.9	2.8
	M5 x 0.8	KJT23-M5	10			13.2	14.3				3.2
	R 1/8	KJT23-01S	10			15.2	15.4*				7.4
4	M3 x 0.5	KJT04-M3	7	9.3	15.6	13	15.1	12.7	0.9	0.9	3.1
	M5 x 0.8	KJT04-M5	10			13.7	15.3				4.5
	R 1/8	KJT04-01S	10			15.7	16.4*				7.7
6	M5 x 0.8	KJT06-M5	7	11.6	16.1	14.7	17.4	13.5	4.5	4.5	4.4
	R 1/8	KJT06-01S	10			17.8	18.5*				11

* Reference dimensions after R thread installation.
Note) ϕD : Max. diameter

<M3, M5>

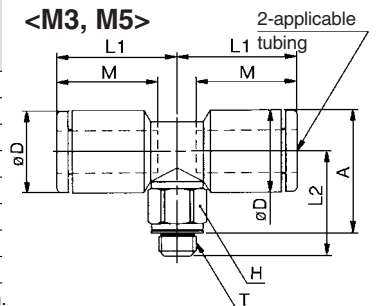

<R 1/8>

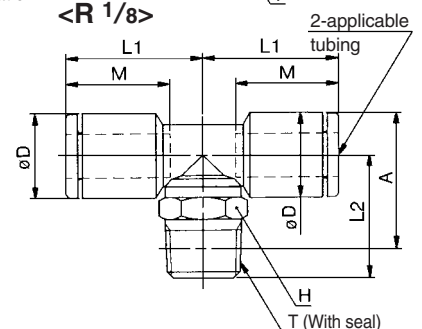

Union Tee: KJT

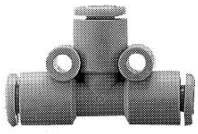

Applicable tubing O.D. (mm)	Model	Note) ϕD	L	Q	M	Effective area (mm ²)		Weight (g)
						Nylon	Urethane	
3.2	KJT23-00	8.4	15	5.8	12.7	3.2	2.7	2.5
4	KJT04-00	9.3	15.8	6.3	12.7	4.5	4.5	3
6	KJT06-00	11.6	17.1	7.3	13.5	11	11	4.6

Note) ϕD : Max. diameter

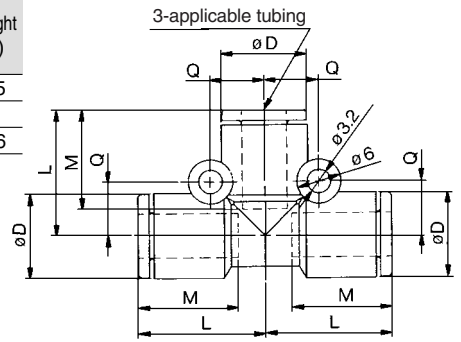

Different Diameter Tee: KJT

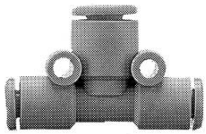

Applicable tubing O.D. (mm)		Model	Note) $\phi D1$	Note) $\phi D2$	L1	L2	Q1	Q2	M1	M2	Effective area (mm ²)		Weight (g)
a	b										Nylon	Urethane	
3.2	4	KJT23-04	9.3	8.4	15.3	15.8	5.8	6.3	12.7	12.7	4.5	4.5	2.8
4	6	KJT04-06	11.6	9.3	16.6	16.8	6.3	7.3	13.5	12.7	8	8	3.7

Note) $\phi D1, \phi D2$: Max. diameter

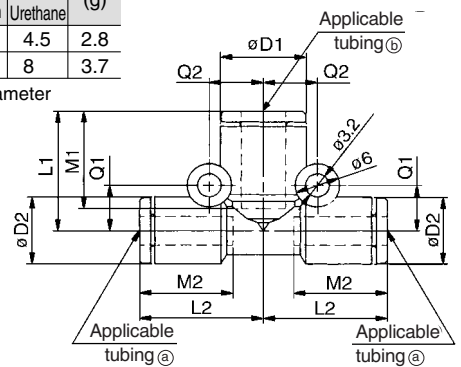

Male Run Tee: KJY

<M3, M5>

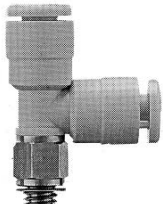

<R 1/8>

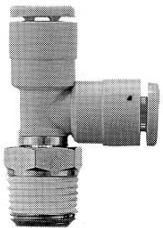

Applicable tubing O.D. (mm)	Connection thread T	Model	H (width across flats)	Note) ϕD	L1	L2	L3	A	M	Effective area (mm ²)		Weight (g)
										Nylon	Urethane	
3.2	M3 x 0.5	KJY23-M3	7	8.4	15.4	14.8	12.5	24.7	12.7	0.9	0.9	2.8
	M5 x 0.8	KJY23-M5								3.2	2.7	7.4
	R 1/8	KJY23-01S								15.2	26*	
4	M3 x 0.5	KJY04-M3	7	9.3	15.6	14.8	13	25.2	12.7	0.9	0.9	3.1
	M5 x 0.8	KJY04-M5								4.5	4.5	3.5
	R 1/8	KJY04-01S								15.7	26.5*	7.7
6	M5 x 0.8	KJY06-M5	7	11.6	17.1	17.1	14.7	28.7	13.5	4.5	4.5	4.5
	R 1/8	KJY06-01S								17.5	16.6	16.7

* Reference dimensions after R thread installation.
Note) ϕD : Max. diameter

<M3, M5>

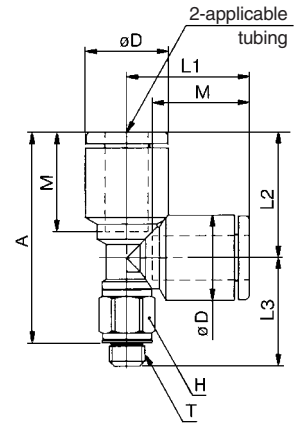

<R 1/8>

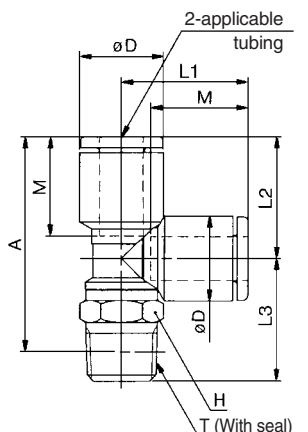

Series KJ

Union "Y": KJU

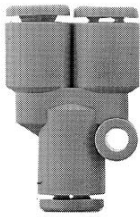

Applicable tubing O.D. (mm)	Model	Note) øD	L1	L2	P	Q	M1	M2	Effective area (mm ²)		Weight (g)
									Nylon	Urethane	
3.2	KJU23-00	8.4	28.5	19	8.4	5.8	12.7	12.9	3.2	2.7	2.6
4	KJU04-00	9.3	27.9	18.3	9.3	6.3	12.7	12.9	4.5	4.5	3
6	KJU06-00	11.6	31.2	21.6	11.6	7.3	13.5	13.7	11	11	4.7

Note) øD: Max. diameter

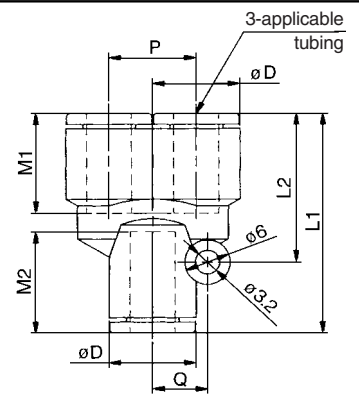

Different Diameter Union "Y": KJU

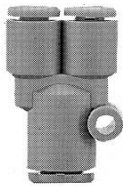

Applicable tubing O.D. (mm)		Model	Note) øD1	Note) øD2	L1	L2	P	Q	M1	M2	Effective area (mm ²)		Weight (g)
a	b										Nylon	Urethane	
3.2	4	KJU23-04	8.4	9.3	27.5	18.3	8.4	6.3	12.7	12.9	4.5	4.5	2.7
4	6	KJU04-06	9.3	11.6	29.2	19.3	9.3	7.3	12.7	13.7	8	8	3.7

Note) øD1, øD2: Max. diameter

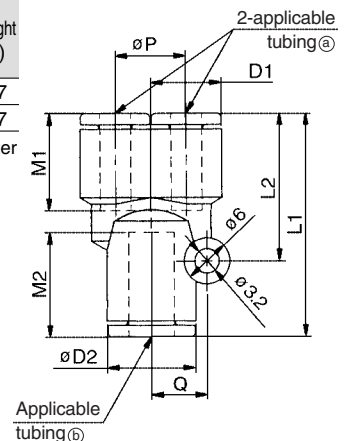

Plug-in "Y": KJU



Applicable tubing O.D. (mm)	Applicable fitting size ød	Model	Note) øD1	øD2	L	P	A	M	Effective area (mm ²)		Weight (g)
									Nylon	Urethane	
3.2	3.2	KJU23-99	8.4	10	43.5	8.4	34.1	12.7	3.2	2.7	2.7
4	4	KJU04-99	9.3	10	44.7	9.3	35.3	12.7	4.5	4.5	3.2
6	6	KJU06-99	11.6	10	47.8	11.6	37.6	13.5	11	11	4.5

Note) øD1: Max. diameter

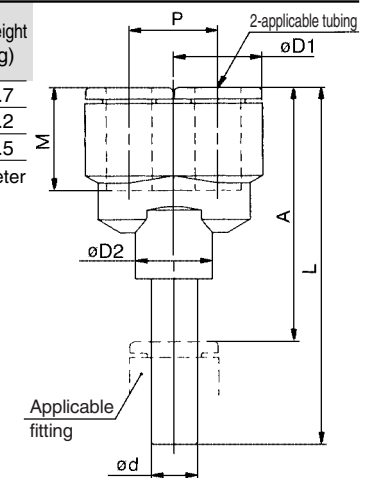

Different Diameter Plug-in "Y": KJX

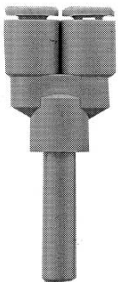

Applicable tubing O.D. (mm)	Applicable fitting size ød	Model	Note) øD1	øD2	L	P	A	M	Effective area (mm ²)		Weight (g)
									Nylon	Urethane	
3.2	4	KJX23-04	8.4	10	44	8.4	34.6	12.7	4.5	4.5	2.8
4	6	KJX04-06	9.3	10	45.7	9.3	35.5	12.7	8	8	3.5

Note) øD1: Max. diameter

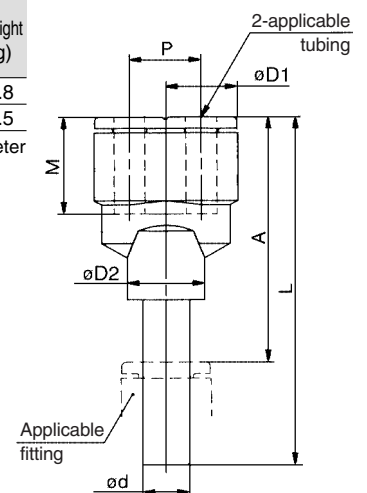

Branch: KJU

<M5>

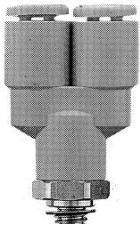

<R 1/8>

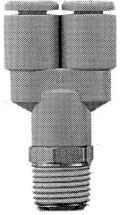

Applicable tubing O.D. (mm)	Connection thread T	Model	H (width across flats)	Note) øD1	øD2	L	P	A	M	Effective area (mm ²)		Weight (g)
										Nylon	Urethane	
3.2	M5 x 0.8	KJU23-M5	10	8.4	10	30.6	8.4	27.5	12.7	2.2	2.2	5.9
	R 1/8	KJU23-01S								3.2	2.7	8.3
4	M5 x 0.8	KJU04-M5	10	9.3	10	31.3	9.3	28.2	12.7	2.2	2.2	6.4
	R 1/8	KJU04-01S								4.5	4.5	8.8
6	M5 x 0.8	KJU06-M5	10	11.6	10	33.4	11.6	30.3	13.5	2.2	2.2	7.4
	R 1/8	KJU06-01S								11	11	9.9

* Reference dimensions after R thread installation.
Note) øD: Max. diameter

<M5>

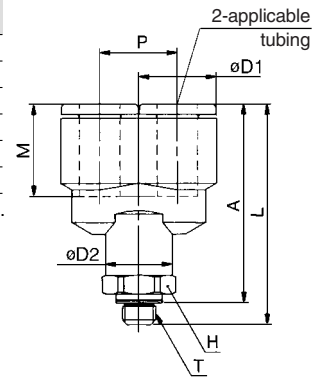

<R 1/8>

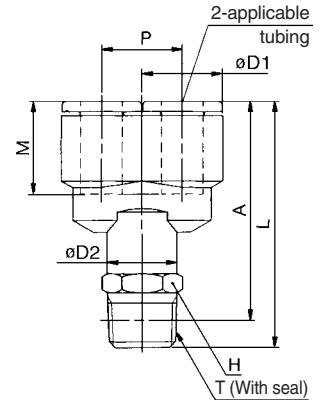

K□

M□

H□

D□

MS

T□

VMG

Plug-in Reducer: KJR



Applicable tubing O.D. (mm)	Applicable fitting size ød	Model	Note) øD	L	A	M	Effective area (mm ²)		Weight (g)
							Nylon	Urethane	
3.2	4	KJR23-04	8.4	32	19.3	12.7	3	2.5	0.9
	6	KJR23-06		33	19.5		1.1		
4	6	KJR04-06	9.3	33.5	20	12.7	4	4	1.3

Note) øD: Max. diameter

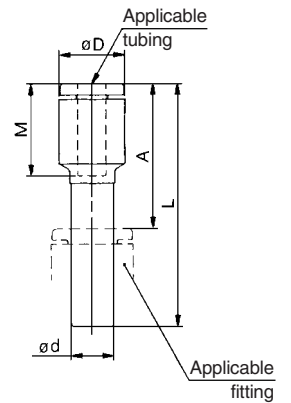

Bulkhead Union: KJE



Applicable tubing O.D. (mm)	Model	T	H (width across flats)	L	Mounting hole	M	Effective area (mm ²)		Weight (g)
							Nylon	Urethane	
3.2	KJE23-00	M8 x 0.75	10	26	9	12.7	3	2.5	4.6
4	KJE04-00	M9 x 0.75	11	26	10	12.7	4	4	5.6
6	KJE06-00	M11 x 0.75	14	27.7	12	13.5	10	10	8.5

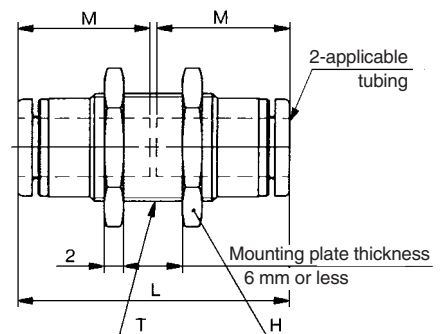

Miniature One-touch Fittings

Inch-size One-touch Mini

Series KJ

Applicable Tubing : $\phi 1/8''$, $\phi 5/32''$, $\phi 1/4''$

Connection Thread : 10-32 UNF, NPT 1/16, NPT 1/8

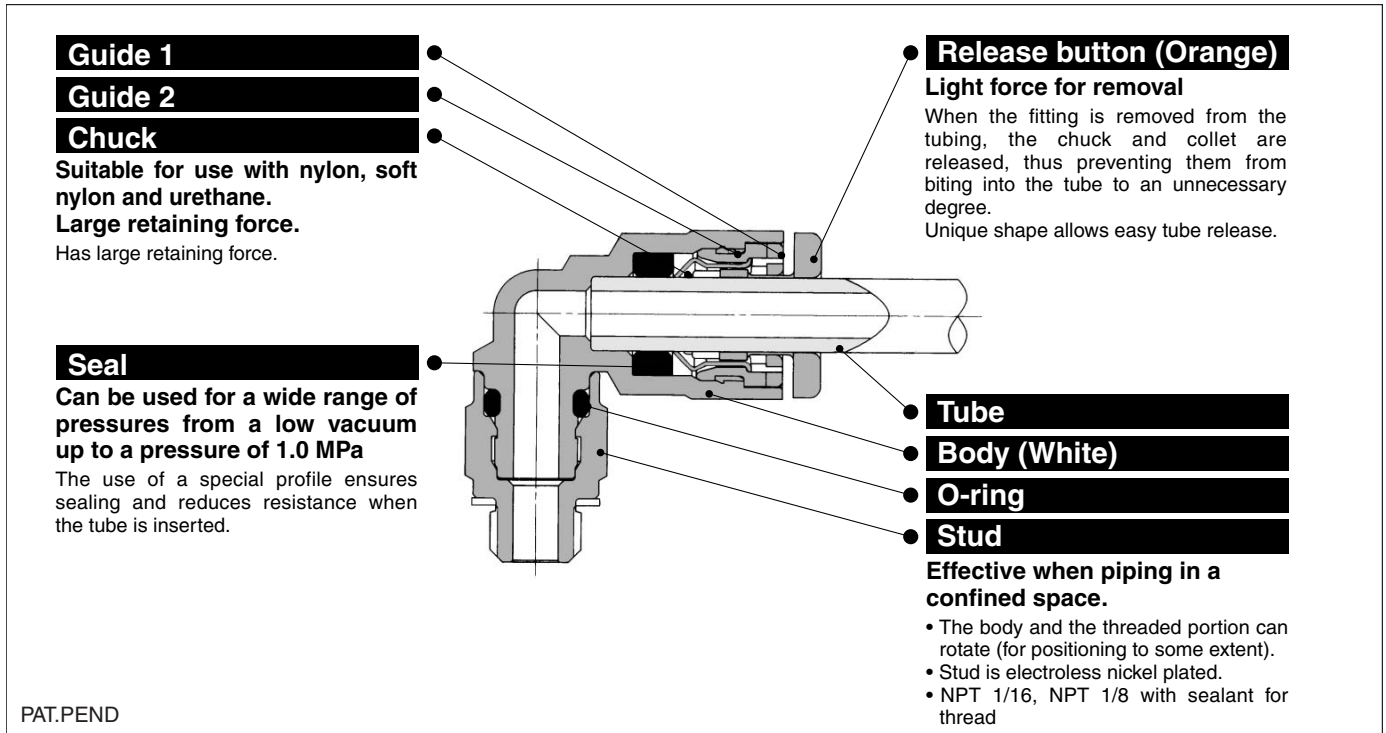

- K
- M
- H
- D
- MS
- T
- VMG

Optimum piping in less space with 20% reduction of the outside

Thread seal is standard.
Copper-free specifications (Electroless nickel plated)

Possible to use from vacuum -100 kPa



Applicable Tubing

Tubing material	Nylon, Soft nylon, Polyurethane
Tubing O.D.	$\phi 1/8$, $\phi 5/32$, $\phi 1/4$

Specifications











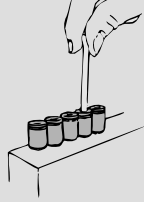

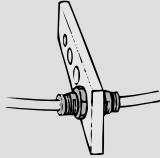
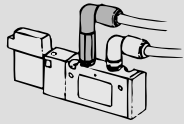







Fluid	Air/Water ^{Note)}	
Maximum operating pressure	1.0 MPa	
Operating vacuum pressure	-100 kPa	
Proof pressure	3.0 MPa	
Ambient and fluid temperature	-5 to 60°C (Water: 0 to 40°C) (No freezing)	
Thread	Mounting section	ANSI/ASME B1.20.1-1983 (NTP thread) JIS B 0212 2A, Class 2B (UNF thread)
	Nut section	JIS B 0212 2A, Class 2B (UNF thread)
Thread seal (Standard)	With thread seal	
Copper-free (Standard)	Brass parts are all electroless nickel plated.	

Note) Applicable for general industrial water. Please consult with SMC if using for other kinds of fluid.
Also, the surge pressure must be under the maximum operating pressure.

Principal Parts Material

Body	Stainless steel 303, C3604BD, PBT
Stud	C3604BD (Thread portion)
Chuck, Guide 2	Stainless steel 304
Release button, Guide 1	POM
Seal, O-ring	NBR
Gasket	Stainless steel 304, NBR

Series KJ

Model					
Hex. socket head male connector KJS P. 3 	Internal hex. allows thread connection by using an allen wrench for confined spaces. 	Bulkhead union KJE P. 8 	Use to connect tubes through a panel. 	Extended male elbow KJW P. 5 	Basically, it is used together with male elbow. Different point is that it is used for fittings to avoid from interfering with each other by making the piping two-level.
Male connector KJH P. 3 	Use to pipe in the same direction from female thread. Most general style.	Plug-in elbow KJL P. 4 	Use to change by 90° in a tube fetching direction from One-touch fittings.	Union "Y" KJU P. 7 	Use to branch line in the same direction.
Female connector KJF P. 3 	Use to pipe from male thread such as pressure gauge.	Reducer elbow KJL P. 5 	Use to change by 90° in tube fetching direction from One-touch fittings and to size down.	Different dia. union "Y" KJU P. 7 	Use to branch line with size down in the same direction.
Straight union KJH P. 3 	Use to connect tubes in the same direction.	Male branch tee KJT P. 5 	Use to branch line from female thread in both 90° directions.	Plug-in "Y" KJU P. 7 	Use to branch line in the same direction from One-touch fittings.
Different diameter straight KJH P. 4 	Use to connect different sized tubes.	Union tee KJT P. 6 	Use to connect tubes in both 90° directions.	Different diameter plug-in "Y" KJX P. 7 	Use to branch line with size down in the same direction from One-touch fittings.
Male elbow KJL P. 4 	Use to pipe at right angles to female thread. Most general styles.	Different diameter tee KJT P. 6 	Use to connect tubes with size down in both 90° directions.	Branch "Y" KJU P. 8 	Use to branch line in the same direction from female thread.
Union elbow KJL P. 4 	Use to connect tubes at right angles.	Male run tee KJY P. 6 	Use to branch line in the same direction from female thread and in 90° direction.	Plug-in reducer KJR P. 8 	Use to size down One-touch fittings.

Gasket/10-32 UNF seal on thread

Part no.: M-10/32G

Material: Stainless steel 304, NBR

⚠ Precautions

Be sure to read before handling. Refer to pages 15-18-3 to 15-18-4 for Safety Instructions and Common Precautions on the products mentioned in this catalog, and refer to pages 15-1-10 to 15-1-11 for Precautions on every series.

Interchangeability of Series KJ and KQ

⚠ Caution

- Do not use the plug-in KQ Series with the KJ Series, it will not hold.
- For combinations other than the plug-in KQs, they are interchangeable.

Installation and Removal of One-touch Mini Fittings

⚠ Caution

Installing of tube

- Cut the tube perpendicularly, using caution not to damage its surface. (Use tube cutter "TK-1", "TK-2" or "TK-3". Do not cut the tube with cutting pliers, nippers, scissors, etc.)
- Grasp the tube, then slowly push it until ↓ it comes to a stop.
- Then, pull it back gently to make sure that it does not come out.

Removing of tube

(Use one hand for removal.)

- Hold the release button with the thumb ↓ and forefinger.
- Grasp the tube with the remaining three ↓ fingers and palm.
- Then, pull out the tube with three fingers ↓ and palm while pushing in the release button with the thumb and the forefinger.
- To reuse the released tube, cut off the damaged portion of the tube.

Male Connector: KJH

<10-32 UNF>	Applicable tubing O.D. (inch)	Connection thread (T) UNF NPT	Model	H (Width across flats)	L	A	M	Max. port size	Weight (g)
	1/8	10-32 UNF	KJH01-32	7	16.7	13.6	12.7	2.3	2
		1/16	KJH01-33S	9.5	18.8	14.8 *		2.5	5
		1/8	KJH01-34S	11.11	13.8	9.8 *		4.7	
	5/32	10-32 UNF	KJH03-32	8	17	13.9	12.7	2.3	2.4
		1/16	KJH03-33S	9.5	19.5	15.5 *		3	4.7
		1/8	KJH03-34S	11.11	14.8	10.8 *		4.6	
<NPT>	1/4	10-32 UNF	KJH07-32		18.4	15.3	13.6	2.3	3.3
		1/16	KJH07-33S	11.11	22	18 *		3.5	6.2
		1/8	KJH07-34S		18.4	14.4 *		4.6	5.2

<10-32 UNF>

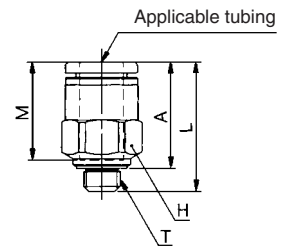

<NPT>

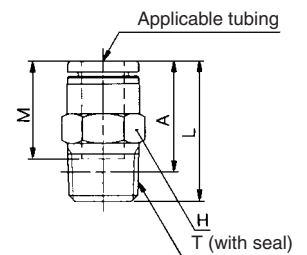

* Reference dimensions after NPT thread installation.

Hexagon Socket Head Male Connector: KJS

<10-32 UNF>	Applicable tubing O.D. (inch)	Connection thread (T) UNF NPT	Model	H (Width across flats)	Note) øD	L	A	M	Min. port size	Weight (g)
	1/8	10-32 UNF	KJS01-32	2	7	19.7	16.6	12.7	2	2.8
		10-32 UNF	KJS03-32	2.5	8	18.7	15.6	2.5	2.7	
	5/32	1/16	KJS03-33S	2.78	10.3	19.6	15.6 *	12.7	2.8	4
		1/8	KJS03-34S	5.4						
<NPT>	1/4	10-32 UNF	KJS07-32	2.5	10.3	21.1	17.1 *	13.6	2.5	3.3
		1/16	KJS07-33S	3.57					3.6	5.8
		1/8	KJS07-34S	4.76					4.8	5.2

<10-32 UNF>

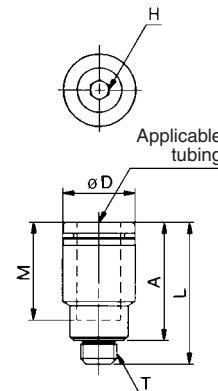

<NPT>

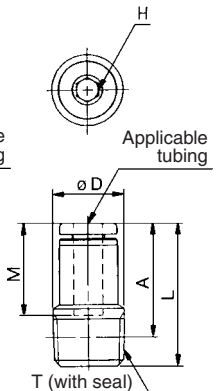

* Reference dimensions after NPT thread installation.
Note) øD: Max. diameter

Female Connector: KJF

Applicable tubing O.D. (inch)	Connection thread (T) UNF	Model	H (Width across flats)	Note) øD	L1	L2	M	Min. port size	Weight (g)
1/8	10-32 UNF	KJF01-32	7	6.9	18.8	7.9	12.7	2.5	2.8
5/32	10-32 UNF	KJF03-32	8	7.9	18.7	7.8	12.7	3	3.8
1/4	10-32 UNF	KJF07-32	11.11	10.3	18	7.5	13.6	4	5.3

Note) øD: Max. diameter

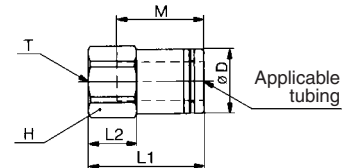

Straight Union: KJH

Applicable tubing O.D. (inch)	Model	Note) øD	L	M	Min. port size	Weight (g)
1/8	KJH01-00	8.4	26.3	12.7	2.5	1.4
5/32	KJH03-00	9.3	26.3	12.7	3	1.7
1/4	KJH07-00	12	28.1	13.6	4.6	2.6

Note) øD: Max. diameter

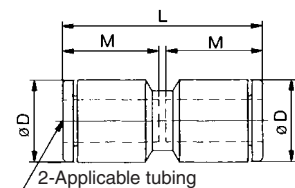

- K
- M
- H
- D
- MS
- T
- VMG

Series KJ

Different Diameter Straight: KJH



Applicable tubing O.D. (inch)		Model	Note)	Note)	L	M1	M2	Max. port size	Weight (g)
(a)	(b)		øD1	øD2					
1/8	5/32	KJH01-03	8.4	9.3	26.3	12.7	12.7	2.5	1.6
	1/4	KJH01-07		12	27.2		13.6		2.1
5/32	1/4	KJH03-07	9.3	12	27.2	12.7	13.6	3	2.3

Note) øD1, øD2: Max. diameter

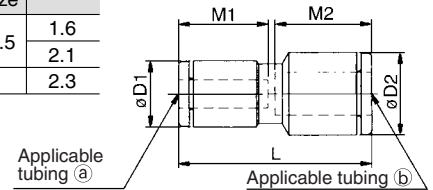

Male Elbow: KJL

<10-32 UNF>



Applicable tubing O.D. (inch)	Connection thread (T) UNF NPT	Model	H (Width across flats)	Note)	L1	L2	A	M	Min. port size	Weight (g)
				øD						
1/8	10-32 UNF	KJL01-32	7	8.4	15.3	13.2	14.3	12.7	2.3	2.5
	1/16	KJL01-33S	9.5			16.4	16.6 *			5.9
	1/8	KJL01-34S	11.11			15.4	15.6 *			6.7
5/32	10-32 UNF	KJL03-32	7	9.3	15.6	13.7	15.3	12.7	2.3	2.7
	1/16	KJL03-33S	9.5			16.9	17.6 *			4.5
	1/8	KJL03-34S	11.11			15.9	16.6 *			6.8
1/4	10-32 UNF	KJL07-32	7	12	16.1	15.1	18	13.6	2.3	3.2
	1/16	KJL07-33S	9.5			18.3	20.3 *			5.3
	1/8	KJL07-34S	11.11			17.8	19.3 *			6.4

<10-32 UNF>

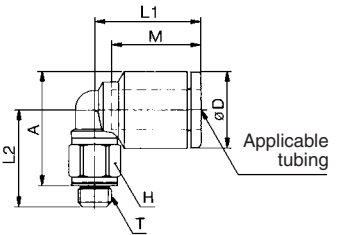

<NPT>



* Reference dimensions after NPT thread installation.
Note) øD: Max. diameter

<NPT>

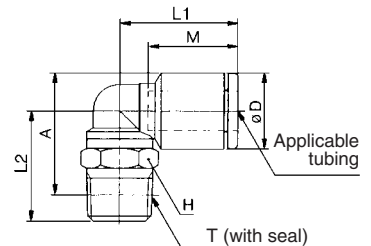

Union Elbow: KJL



Applicable tubing O.D. (inch)	Model	Note)	L	Q	M	Min. port size	Weight (g)
		øD					
1/8	KJL01-00	8.4	15	5.8	12.7	2.5	1.6
5/32	KJL03-00	9.3	15.8	6.3	12.7	3	2
1/4	KJL07-00	12	17.4	7.6	13.6	4.6	3.3

Note) øD: Max. diameter

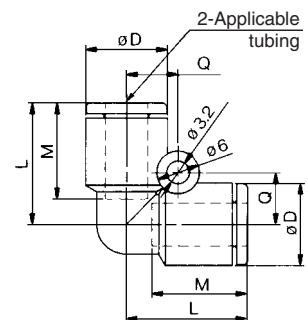

Plug-in Elbow: KJL



Applicable tubing O.D. (inch)	Applicable fitting size ød (inch)	Model	Note)	øD1	øD2	L1	L2	A	M	Min. port size	Weight (g)
1/8	1/8	KJL01-99	8.4	6	14.5	23.8	15.3	12.7	2.2	1	
5/32	5/32	KJL03-99	9.3	6	15.6	24.7	16.7	12.7	2.5	1.2	
1/4	1/4	KJL07-99	12	7.6	16.7	27	19.4	13.6	4.6	2.1	

Note) øD1: Max. diameter

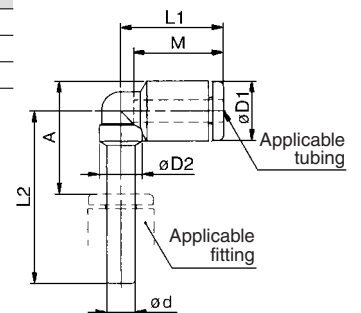

Reducer Elbow: KJL



Applicable tubing O.D. (inch)	Applicable fitting size ϕd (inch)	Model	Note) $\phi D1$	$\phi D2$	L1	L2	A	M	Min. port size	Weight (g)
1/8	5/32	KJL01-03	8.4	6	14.5	24.3	15.8	12.7	2.2	1.1
	1/4	KJL01-07								
5/32	1/4	KJL03-07	9.3	6.35	14.9	26.2	17.3	12.7	2.5	1.5

Note) $\phi D1$: Max. diameter

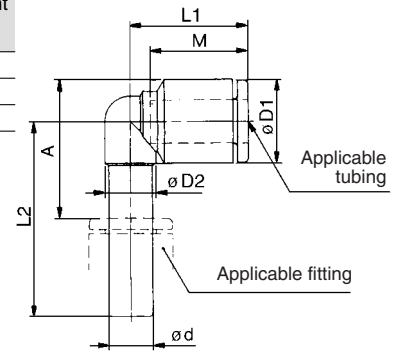

Extended Male Elbow: KJW

<10-32 UNF>



Applicable tubing O.D. (inch)	Connection thread (T) UNF NPT	Model	H (Width across flats)	Note) ϕD	L1	L2	A	M	Min. port size	Weight (g)		
1/8	10-32 UNF	KJW01-32	7	8.4	15.3	26.2	27.3	12.7	2.3	6.2		
	1/16	KJW01-33S	9.5			29.4	29.6*				2.5	11.5
	1/8	KJW01-34S	11.11			25.7	25.9*					
5/32	10-32 UNF	KJW03-32	7	9.3	15.6	26.7	28.3	12.7	2.3	6.4		
	1/16	KJW03-33S	9.5			29.9	30.6*				2.5	11.7
	1/8	KJW03-34S	11.11			26.2	26.9*					
1/4	10-32 UNF	KJW07-32	7	12	16.1	28.1	31	13.6	2.3	6.9		
	1/16	KJW07-33S	9.5			31.3	33.3*				2.5	10.7
	1/8	KJW07-34S	11.11			17.8	30.3					

* Reference dimensions after NPT thread installation.
Note) ϕD : Max. diameter

<NPT>



<10-32 UNF>

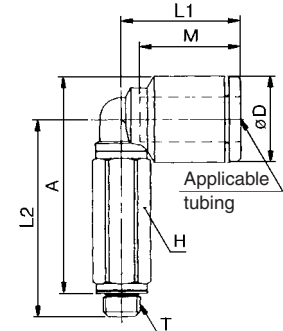

<NPT>

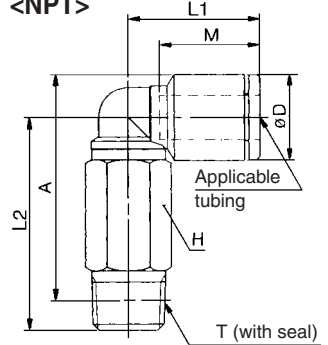

Male Branch Tee: KJT

<10-32 UNF>



Applicable tubing O.D. (inch)	Connection thread (T) UNF NPT	Model	H (Width across flats)	Note) ϕD	L1	L2	A	M	Min. port size	Weight (g)		
1/8	10-32 UNF	KJT01-32	7	8.4	15.3	13.2	14.3	12.7	2.3	3.2		
	1/16	KJT01-33S	9.5			16.4	16.6*				2.5	6.6
	1/8	KJT01-34S	11.11			15.4	15.6*					
5/32	10-32 UNF	KJT03-32	7	9.3	15.6	13.7	15.3	12.7	2.3	3.5		
	1/16	KJT03-33S	9.5			16.9	17.6*				2.5	6.9
	1/8	KJT03-34S	11.11			15.9	16.6*					
1/4	10-32 UNF	KJT07-32	7	12	16.1	15.1	18	13.6	2.3	4.4		
	1/16	KJT07-33S	9.5			18.3	20.3*				2.5	6.8
	1/8	KJT07-34S	11.11			17.8	17.3					

* Reference dimensions after NPT thread installation.
Note) ϕD : Max. diameter

<NPT>



<10-32 UNF>

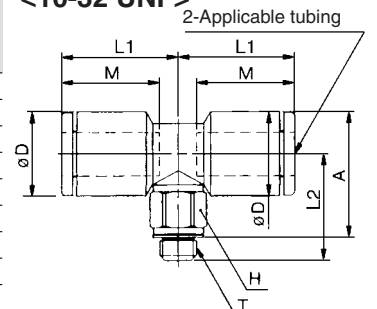

<NPT>

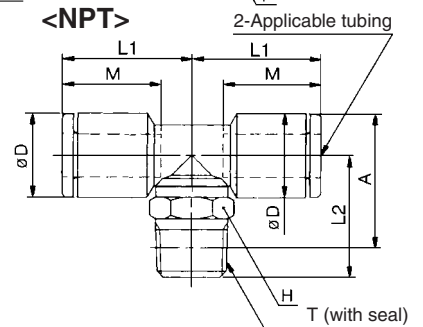

Series KJ

Union Tee: KJT

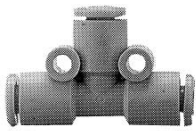

Applicable tubing O.D. (inch)	Model	Note) ϕD	L	Q	M	Min. port size	Weight (g)
1/8	KJT01-00	8.4	15	5.8	12.7	2.5	2.5
5/32	KJT03-00	9.3	15.8	6.3	12.7	3	3
1/4	KJT07-00	12	17.4	7.6	13.6	4.6	4.8

Note) ϕD : Max. diameter

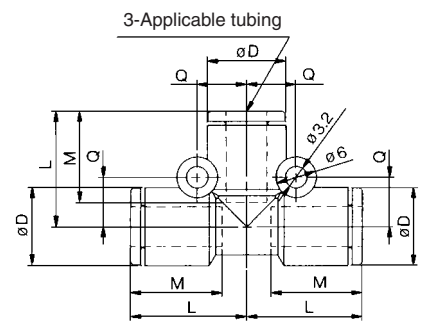

Different Diameter Tee: KJT

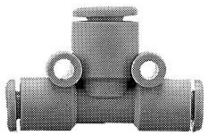

Applicable tubing O.D. (inch)		Model	Note) $\phi D1$	Note) $\phi D2$	L1	L2	Q1	Q2	M1	M2	Min. port size	Weight (g)
a	b											
1/8	5/32	KJT01-03	9.3	8.4	15.3	15.8	5.8	6.3	12.7	12.7	2.5	2.8
5/32	1/4	KJT03-07	12	9.3	16.4	16.8	6.3	7.6	13.6	12.7	2.5	3.9

Note) $\phi D1$, $\phi D2$: Max. diameter

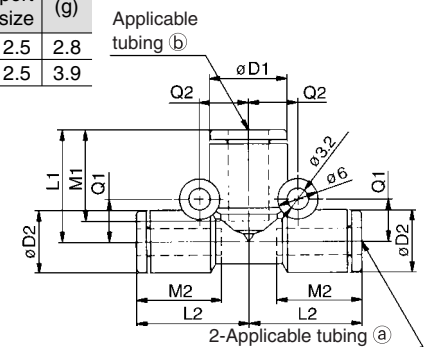

Male Run Tee: KJY

<10-32 UNF>

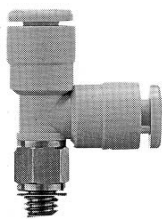

Applicable tubing O.D. (inch)	Connection thread (T) UNF NPT	Model	H (Width across flats)	Note) ϕD	L1	L2	L3	A	M	Min. port size	Weight (g)
1/8	10-32 UNF	KJY01-32	7	8.4	15.4	14.8	13.2	24.9	12.7	2.3	3.2
	1/16	KJY01-33S	9.5							2.5	5.1
	1/8	KJY01-34S	11.11							2.5	7.4
5/32	10-32 UNF	KJY03-32	7	9.3	15.6	14.8	13.7	25.4	12.7	2.3	3.5
	1/16	KJY03-33S	9.5							2.5	5.4
	1/8	KJY03-34S	11.11							2.5	7.7
1/4	10-32 UNF	KJY07-32	7	12	17.6	17.6	15.1	29.6	13.6	2.3	4.5
	1/16	KJY07-33S	9.5							2.5	6.7
	1/8	KJY07-34S	11.11							4.6	7.5

* Reference dimensions after NPT thread installation.
Note) ϕD : Max. diameter

<10-32 UNF>

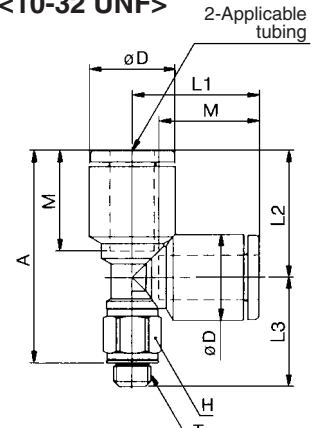

<NPT>

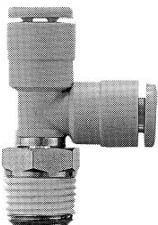

<NPT>

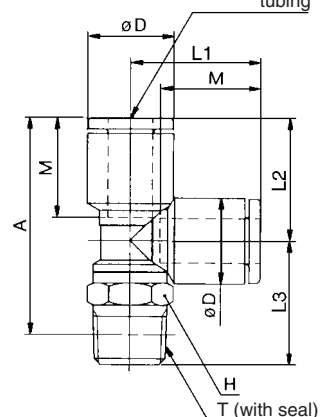

Union "Y": KJU

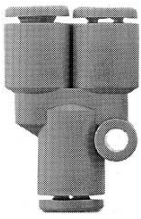

Applicable tubing O.D. (inch)	Model	Note) ϕD	L1	L2	P	Q	M1	M2	Min. port size	Weight (g)
1/8	KJU01-00	8.4	28.5	19	8.4	5.8	12.7	12.9	2.5	2.6
5/32	KJU03-00	9.3	27.9	18.3	9.3	6.3	12.7	12.9	3	3
1/4	KJU07-00	12	32.3	22.7	12	7.6	13.6	13.8	4.6	5

Note) ϕD : Max. diameter

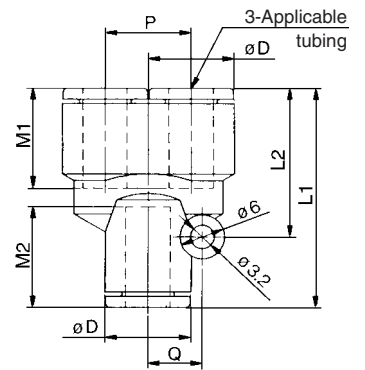

Different Diameter. Union "Y": KJU

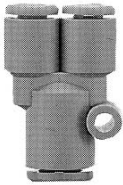

Applicable tubing O.D. (inch)		Model	Note) $\phi D1$	Note) $\phi D2$	L1	L2	P	Q	M1	M2	Min. port size	Weight (g)
a)	b)											
1/8	5/32	KJU01-03	8.4	9.3	27.5	18.3	8.4	6.3	12.7	12.9	2.5	2.7
5/32	1/4	KJU03-07	9.3	12	30.4	20.6	9.3	7.6	12.7	13.8	3	3.9

Note) $\phi D1, \phi D2$: Max. diameter

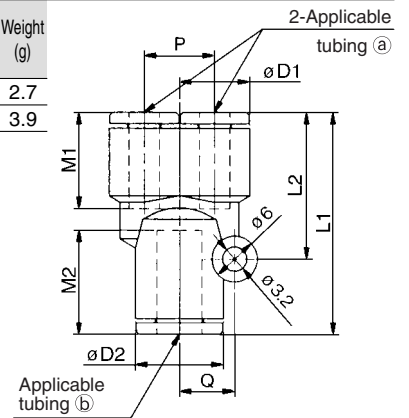

Plug-in "Y": KJU

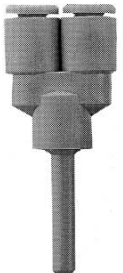

Applicable tubing O.D. (inch)	Applicable fitting size ϕd (inch)	Model	Note) $\phi D1$	$\phi D2$	L	P	A	M	Min. port size	Weight (g)
1/8	1/8	KJU01-99	8.4	10	43.5	8.4	34.1	12.7	2.5	2.7
5/32	5/32	KJU03-99	9.3	10	44.7	9.3	35.3	12.7	3	3.2
1/4	1/4	KJU07-99	12	10	49.9	12	39.6	13.6	4.6	4.7

Note) $\phi D1$: Max. diameter

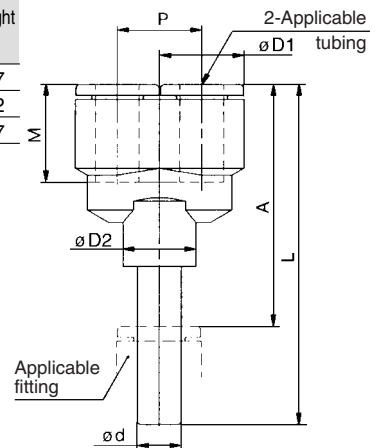

Different Diameter Plug-in "Y": KJX

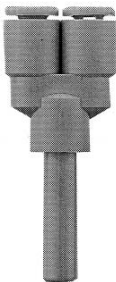

Applicable tubing O.D. (inch)	Applicable fitting size ϕd (inch)	Model	Note) $\phi D1$	$\phi D2$	L	P	A	M	Min. port size	Weight (g)
1/8	5/32	KJX01-03	8.4	10	44	8.4	34.6	12.7	2.5	2.8
5/32	1/4	KJX03-07	9.3	10	45.7	9.3	35.4	12.7	3	3.6

Note) $\phi D1$: Max. diameter

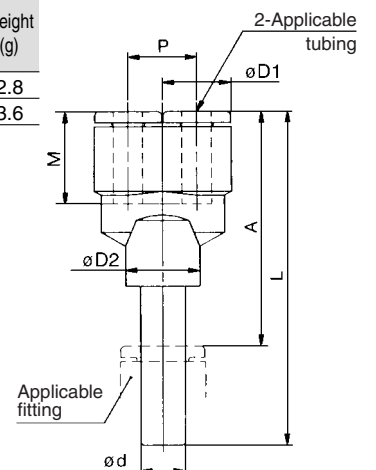

- K
- M
- H
- D
- MS
- T
- VMG

Series KJ

Branch "Y": KJU

<10-32 UNF>

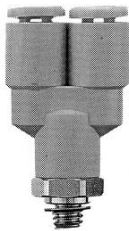

Applicable tubing O.D. (inch)	Connection thread (T) UNF NPT	Model	H (Width across flats)	Note) øD1	øD2	L	P	A	M	Min. port size	Weight (g)
1/8	10-32 UNF	KJU01-32	11.11	8.4	10	30.6	8.4	27.5	12.7	1.8	5.9
	1/16	KJU01-33S				34.1		30.1 *		2.5	8.1
	1/8	KJU01-34S				34.8		30.8 *		3.5	8.8
5/32	10-32 UNF	KJU03-32	11.11	9.3	10	31.3	9.3	28.2	12.7	1.8	6.4
	1/16	KJU03-33S				34.8		30.8 *		3.5	8.8
	1/8	KJU03-34S				35.5		32.4		2.3	7.4
1/4	10-32 UNF	KJU07-32	11.11	12	10	39	12	35 *	13.6	3.5	10
	1/16	KJU07-33S				39		35 *		4.6	10
	1/8	KJU07-34S				39		35 *		4.6	10

<UNF 10-32>

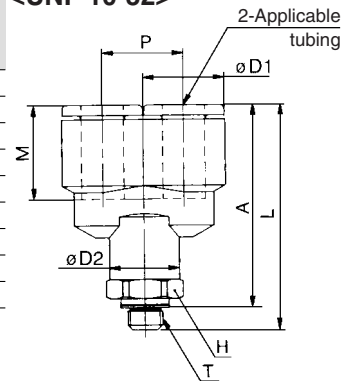

<NPT>

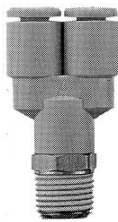

<NPT>

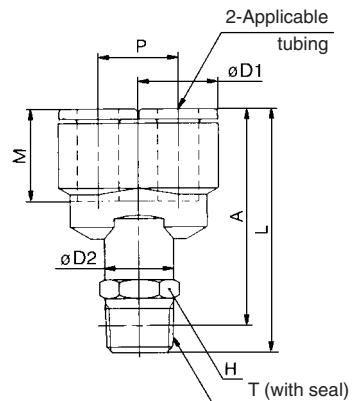

* Reference dimensions after NPT thread installation.
Note) øD1: Max. diameter

Plug-in Reducer: KJR



Applicable tubing O.D. (inch)	Applicable fitting size ød (inch)	Model	Note) øD	L	A	M	Min. port size	Weight (g)
1/8	5/32	KJR01-03	8.4	32	19.3	12.7	2.5	0.9
	1/4	KJR01-07		33	19.4		2.5	1.2
5/32	1/4	KJR03-07	9.3	33.5	19.9	12.7	3	1.4

Note) øD: Max. diameter

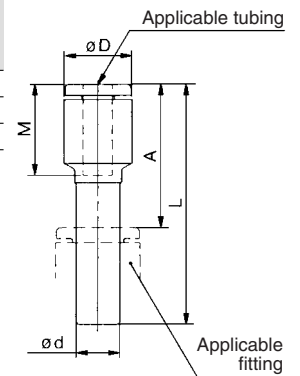

Bulkhead Union: KJE



Applicable tubing O.D. (inch)	Model	Connection thread (T) UNF	H (Width across flats)	L	Mounting hole	M	W	Min. port size	Weight (g)
1/8	KJE01-00	3/8 - 24	12.7	26	10.5	12.7	2.8	2.5	8.1
5/32	KJE03-00	3/8 - 24	12.7	26	10.5	12.7		3	
1/4	KJE07-00	1/2 - 20	15.88	27.8	14	13.6	3.5	4.6	15.7

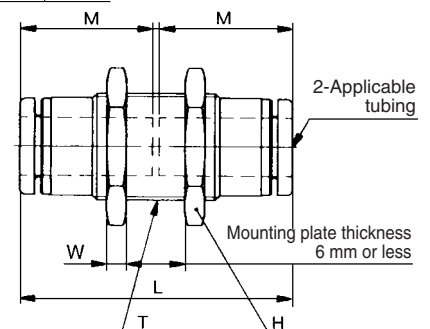

One-touch Mini Series KJ

Applicable tubing O.D.. $\phi 2$
 Connection thread: M3 x 0.5
 M5 x 0.8



Specifications

Applicable tubing material	Polyurethane
Applicable tubing O.D.	$\phi 2$
Fluid	Air, Water ^{Note 1)}
Maximum operating pressure	1 MPa ^{Note 2)}
Operating vacuum pressure	-100 kPa
Proof pressure	3 MPa
Ambient and fluid temperature	-5 to 60°C, For water: 0 to 40°C (No freezing)
Copper-free (Standard)	Brass parts are all electroless nickel plated.

Note 1) Applicable for general industrial water.

Note 2) Apply the maximum operating pressure to the tube during the tube connection.

How to Order

KJ H 02-M3

Model ●

H	Male connector Straight union Different diameter straight
S	Hexagon socket head male connector
L	Male elbow
W	Extended male elbow
T	Male branch tee Union tee
Y	Male run tee Union "Y"
U	Different diameter union "Y"
R	Plug-in reducer
E	Bulkhead union

● Port size

M3	M3 x 0.5
M5	M5 x 0.8
00	Same diameter tubing
23 ^{Note 1)}	$\phi 3.2$
04 ^{Note 1)}	$\phi 4$

Note 1) Different diameter tubing O.D.

● Applicable tubing O.D. $\phi 2$

*) Plug: KJP-02

Variation

Male connector
KJH



Hexagon socket head male connector
KJS



Straight union
KJH



Different diameter straight
KJH



Male elbow
KJL



Extended male elbow
KJW



Male branch tee
KJT



Union tee
KJT



Male run tee
KJY



Union "Y"
KJU



Different diameter union "Y"
KJU



Plug-in reducer
KJR



Bulkhead union
KJE



Plug
KJP



Series KJ

Male connector KJH



Applicable tubing O.D. (mm)	Model	T Connection thread	H (Width across flats)	øD	L	A	M	Effective area (mm ²)	Weight (g)
2	KJH02-M3	M3 x 0.5	5.5	6	12.5	10	8.8	0.9	1.1
	KJH02-M5	M5 x 0.8	7	7.8	11.7	8.7	8.8	0.9	1.9

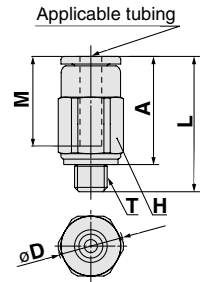

Hexagon socket head male connector KJS



Applicable tubing O.D. (mm)	Model	T Connection thread	H (Width across flats)	øD	L	A	M	Effective area (mm ²)	Weight (g)
2	KJS02-M3	M3 x 0.5	1.5	5.5	12.5	10	8.8	0.9	1.1

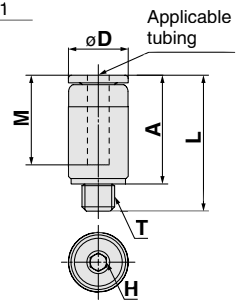

Straight union KJH



Applicable tubing O.D. (mm)	Model	øD1	L	M	Effective area (mm ²)	Weight (g)
2	KJH02-00	6	17.8	8.8	0.8	1.0

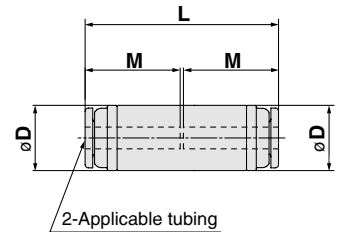

Different diameter straight: KJH



Applicable tubing O.D. (mm)		Model	øD	L	M1	M2	Effective area (mm ²)	Weight (g)
a	b							
2	3.2	KJH02-23	8.4	26.6	8.8	12.7	0.9	2.4
	4	KJH02-04	9.3	26.6	8.8	12.7	0.9	3.2

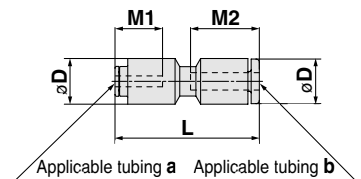

Male elbow KJL



Applicable tubing O.D. (mm)	Model	T Connection thread	H (Width across flats)	øD1	øD2	L1	L2	A	M	Effective area (mm ²)	Weight (g)
2	KJL02-M3	M3 x 0.5	5.5	6	6	9.5	11.6	12.1	8.8	0.8	1.4
	KJL02-M5	M5 x 0.8	7	6	7.8	9.5	12.1	12.1	8.8	0.8	2.4

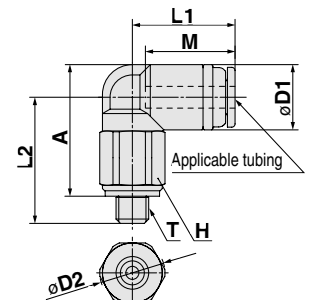

Extended male elbow KJW



Applicable tubing O.D. (mm)	Model	T Connection thread	H (Width across flats)	$\phi D1$	$\phi D2$	L1	L2	A	M	Effective area (mm ²)	Weight (g)
2	KJW02-M3	M3 x 0.5	5.5	6	6	9.5	18.6	19.1	8.8	0.8	2.6
	KJW02-M5	M5 x 0.8	7	6	7.8	9.5	19.1	19.1	8.8	0.8	4.5

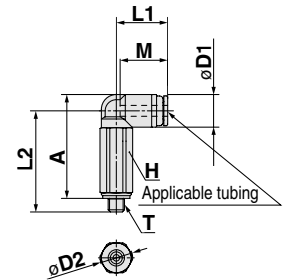

Male branch tee KJT



Applicable tubing O.D. (mm)	Model	T Connection thread	H (Width across flats)	$\phi D1$	$\phi D2$	L1	L2	A	M	Effective area (mm ²)	Weight (g)
2	KJT02-M3	M3 x 0.5	5.5	6	6	9.5	11.6	12.1	8.8	1.1	1.8
	KJT02-M5	M5 x 0.8	7	6	7.8	9.5	12.1	12.1	8.8	1.1	2.8

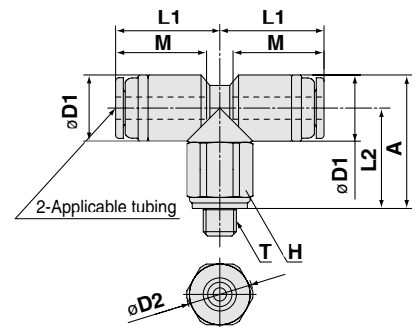

Union tee KJT



Applicable tubing O.D. (mm)	Model	ϕD	L	Q	M	Effective area (mm ²)	Weight (g)
2	KJT02-00	6	10	4.9	8.8	0.9	1.7

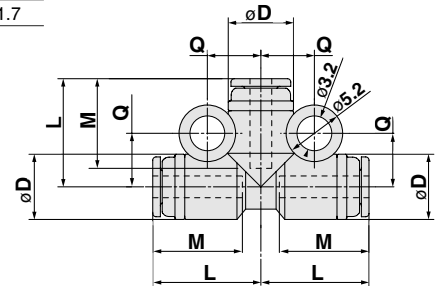

Male branch tee KJY



Applicable tubing O.D. (mm)	Model	T Connection thread	H (Width across flats)	$\phi D1$	$\phi D2$	L1	L2	L3	A	M	Effective area (mm ²)	Weight (g)
2	KJY02-M3	M3 x 0.5	5.5	6	6	10	10	11.6	19.1	8.8	1.1	1.9
	KJY02-M5	M5 x 0.8	7	6	7.8	10	10	12.1	19.1	8.8	1.3	2.9

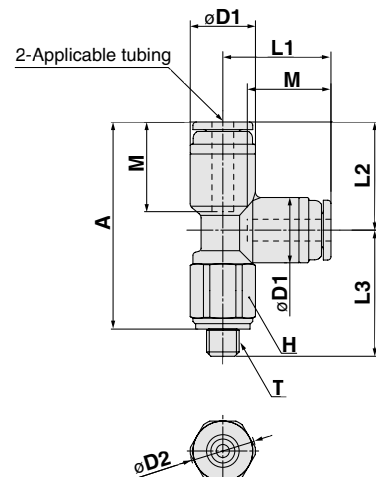

Series KJ

Union "Y" KJU



Applicable tubing O.D. (mm)	Model	øD	L1	L2	P	Q	M	Effective area (mm ²)	Weight (g)
2	KJU02-00	6	20.1	13.4	6.5	4.6	8.8	0.9	1.8

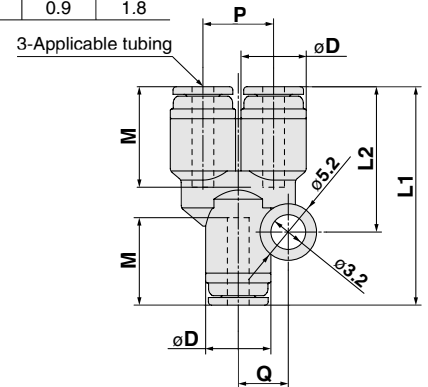

Different diameter union "Y" KJU



Applicable tubing O.D. (mm)		Model	øD1	øD2	L1	L2	P	Q	M1	M2	Effective area (mm ²)	Weight (g)
a	b											
2	3.2	KJU02-23	6	6	28.8	19.2	8.4	5.8	8.8	12.7	1.5	4.7
	4	KJU02-04	6	7.8	28.2	18.5	9.3	6.3	8.8	12.7	1.6	6.0

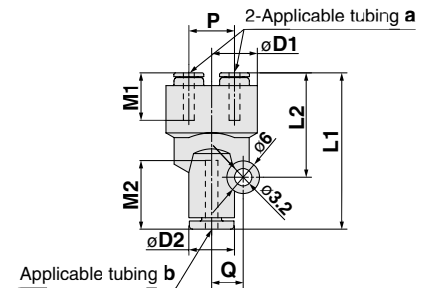

Plug-in reducer KJR



Applicable tubing O.D. (mm)	Model	Applicable fitting size ød	øD	L	A	M	Effective area (mm ²)	Weight (g)
2	KJR02-04	4	6	28.3	15.6	8.8	0.9	0.7

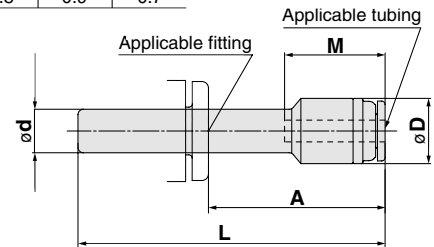

Bulkhead union KJE



Applicable tubing O.D. (mm)	Model	Connection thread	H (Width across flats)	L	Mounting hole	M	Effective area (mm ²)	Weight (g)
2	KJE02-00	M7 x 0.75	9	18.1	8	8.8	0.8	3.7

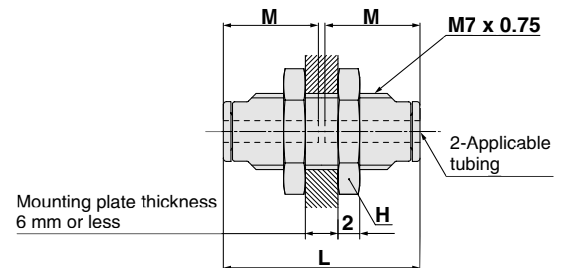

Plug KJP



Applicable tubing O.D. (mm) ød	Model	øD	L	A	Weight (g)
2	KJP-02	3	17	8.2	0.1

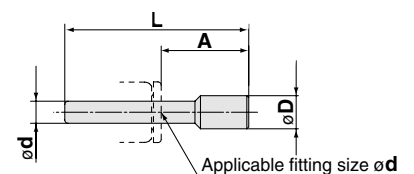





Series KJ/M/TU/AS Safety Instructions

These safety instructions are intended to prevent a hazardous situation and/or equipment damage. These instructions indicate the level of potential hazard by labels of "**Caution**", "**Warning**" or "**Danger**". To ensure safety, be sure to observe ISO 4414 ^{Note 1)}, JIS B 8370 ^{Note 2)} and other safety practices.

■ Explanation of the labels

Labels	Explanation of the labels
 Danger	In extreme conditions, there is a possible result of serious injury or loss of life.
 Warning	Operator error could result in serious injury or loss of life.
 Caution	Operator error could result in injury or equipment damage.

Note 1) ISO 4414: Pneumatic fluid power – General rules relating to systems

Note 2) JIS B 8370: General Rules for Pneumatic Equipment

Note 3) Injury indicates light wounds, burns and electrical shocks that do not require hospitalization or hospital visits for long-term medical treatment.

Note 4) Equipment damage refers to extensive damage to the equipment and surrounding devices.

■ Selection/Handling/Applications

1. The compatibility of the pneumatic equipment is the responsibility of the person who designs the pneumatic system or decides its specifications.

Since the products specified here are used in various operating conditions, their compatibility for the specific pneumatic system must be based on specifications or post analysis and/or tests to meet the specific requirements. The expected performance and safety assurance are the responsibility of the person who has determined the compatibility of the system. This person should continuously review the suitability of all items specified, referring to the latest catalog information with a view to giving due consideration to any possibility of equipment failure when configuring a system.

2. Only trained personnel should operate pneumatically operated machinery and equipment.

Compressed air can be dangerous if handled incorrectly. Assembly, handling or repair of pneumatic systems should be performed by fully knowledgeable and experienced operators. (Understanding JIS B 8370 General Rules for Pneumatic Equipment; and other safety rules are included.)

3. Do not service machinery/equipment or attempt to remove components until safety is confirmed.

1. Inspection and maintenance of machinery/equipment should only be performed once measures to prevent falling or runaway of the driver objects have been confirmed.
2. When equipment is removed, confirm that safety process as mentioned above. Turn off the supply pressure for this equipment and exhaust all residual compressed air in the system, and release all the energy (liquid pressure, spring, condenser, gravity).
3. Before machinery/equipment is restarted, take measures to prevent quick extension of a cylinder piston rod, etc.

4. Contact SMC if the product will be used in any of the following conditions:

1. Conditions and environments beyond the given specifications, or if product is used outdoors.
2. Installation on equipment in conjunction with atomic energy, railway, air navigation, vehicles, medical equipment, food and beverages, recreation equipment, emergency stop circuits, clutch and brake circuits in press applications, or safety equipment.
3. An application which has the possibility of having negative effects on people, property, or animals, requiring special safety analysis.
4. If the products are used in an interlock circuit, prepare a double interlock style circuit with a mechanical protection function for the prevention of a breakdown. And, examine the devices periodically if they function normally or not.

■ Exemption from liability

1. SMC is exempted from liability for any damages caused by earthquakes, fire for which SMC is not responsible for, actions by a third person, accidents, customer error with or without intention, product misuse, and any other damages caused by abnormal operating conditions.

2. SMC is exempted from liability for any accompanied damages, such as profit loss and discontinuation of business operation, caused by the operation or incompetency to operate our products.

3. SMC is exempted from liability for any damages caused by operations, which the catalogs and instruction manuals have not introduced, and operations outside of the specification range.

4. SMC is exempted from liability for any damages caused by malfunctions of our products when combined with other devices or software in which SMC is not involved in.



ø2 Piping Series Specific Product Precautions

Be sure to read this before handling. For Flow Control Equipment Precautions, Fittings & Tubing Precautions, refer to “Precautions for Handling Pneumatic Devices” (M-03-E3A).

Mounting

Caution

1. Tightening of M3 and M5 screws
 - 1) After tightening by hand, the barb elbow type (M-3ALU-2, M-5ALHU-2) should be tighten an additional 1/3 rotations using an appropriate wrench.
 - 2) After tightening by hand, other types should be tightened by an additional 1/6 rotations using a suitable tool.Over tightening can cause air leakage due to damage to the threads and/or deformation of the gasket. Under tightening can cause loose threads and air leakage, etc.

Handling of One-touch Fittings

Caution

1. Tubing attachment/detachment for One-touch fittings
 - 1) Attaching of tubing
 1. Take a tubing having no flaws on its periphery and cut it off at a right angle. When cutting the tubing, use tubing cutters TK-1, 2 or 3. Do not use pinchers, nippers or scissors, etc. If cutting is done with tools other than tubing cutters, the tubing may be cut diagonally or become flattened, etc. This can make a secure installation impossible, and cause problems such as the tubing pulling out after installation or air leakage. Allow some extra length in the tubing.
 2. The polyurethane tubing with internal pressure expands its O.D. This may result in failure of reconnection to One-touch fittings. Examine the tubing and do not cut the tubing but reconnect to the One-touch fittings when its O.D. accuracy is +0.07 or larger in ø2, and +0.15 or larger in ø3.2 and ø4. Make sure the tubing goes through the release bushing smoothly when reconnecting it to the One-touch fittings.
 3. Grasp the tubing and push it in slowly, inserting it securely all the way into the fitting.
 4. After inserting the tubing, pull on it lightly to confirm that it will not come out. If it is not installed securely all the way into the fitting, this can cause problems such as air leakage or the tubing pulling out.
 - 2) Detaching of tubing
 1. Push in the release bushing sufficiently. When doing this, push the collar evenly.
 2. Pull out the tubing while holding down the release bushing so that it does not come out. If the release bushing is not pressed down sufficiently, there will be increased bite on the tubing and it will become more difficult to pull it out.
 3. When the removed tubing is to be used again, cut off the portion which has been chewed before reusing it. If the chewed portion of the tubing is used as is, this can cause trouble such as air leakage or difficulty in removing the tubing.

Precautions on Other Tubing Brand

Caution

1. Tubing O.D. ø3.2, ø4

When using a brand of tubing other than SMC, be careful of the tolerance of the tube's O.D.

1) Nylon tubing	≤ ±0.1 mm
2) Soft nylon tubing	≤ ±0.1 mm
3) Polyurethane tubing	≤ +0.15 mm
	≤ -0.2 mm

When the tolerance of the tube's O.D. is out of range mentioned above, do not use the tube. Because tubing cannot be connected, or it may cause air leakage or tubing to come out after installation.
2. Tubing O.D. ø2

Tubing other than from SMC cannot be used. If other tubing is used, it may not connect, air leakage is likely to occur after piping, or the tubing is likely to detach.

Precautions on Series AS

Caution

1. Suitable tightening torque for the hexagon lock nut is 0.05 N·m. For standard installation, turn 15 to 30° using a tool after fastening by hand. Be careful not to damage the product by over torquing.



Safety Instructions

These safety instructions are intended to prevent a hazardous situation and/or equipment damage. These instructions indicate the level of potential hazard by labels of "Caution", "Warning" or "Danger". To ensure safety, be sure to observe ISO 4414 ^{Note 1)}, JIS B 8370 ^{Note 2)} and other safety practices.

 **Caution** : Operator error could result in injury or equipment damage.

 **Warning** : Operator error could result in serious injury or loss of life.

 **Danger** : In extreme conditions, there is a possible result of serious injury or loss of life.

Note 1) ISO 4414: Pneumatic fluid power--General rules relating to systems.

Note 2) JIS B 8370: General Rules for Pneumatic Equipment

Warning

1. The compatibility of pneumatic equipment is the responsibility of the person who designs the pneumatic system or decides its specifications.

Since the products specified here are used in various operating conditions, their compatibility for the specific pneumatic system must be based on specifications or after analysis and/or tests to meet your specific requirements. The expected performance and safety assurance will be the responsibility of the person who has determined the compatibility of the system. This person should continuously review the suitability of all items specified, referring to the latest catalog information with a view to giving due consideration to any possibility of equipment failure when configuring a system.

2. Only trained personnel should operate pneumatically operated machinery and equipment.

Compressed air can be dangerous if an operator is unfamiliar with it. Assembly, handling or repair of pneumatic systems should be performed by trained and experienced operators.

3. Do not service machinery/equipment or attempt to remove components until safety is confirmed.

1. Inspection and maintenance of machinery/equipment should only be performed once measures to prevent falling or runaway of the driver objects have been confirmed.
2. When equipment is to be removed, confirm the safety process as mentioned above. Cut the supply pressure for this equipment and exhaust all residual compressed air in the system.
3. Before machinery/equipment is restarted, take measures to prevent shooting-out of cylinder piston rod, etc.

4. Contact SMC if the product is to be used in any of the following conditions:

1. Conditions and environments beyond the given specifications, or if product is used outdoors.
2. Installation on equipment in conjunction with atomic energy, railway, air navigation, vehicles, medical equipment, food and beverages, recreation equipment, emergency stop circuits, clutch and brake circuits in press applications, or safety equipment.
3. An application which has the possibility of having negative effects on people, property, or animals, requiring special safety analysis.



Common Precautions

Be sure to read before handling.

For detailed precautions on every series, refer to main text.

Selection

Warning

1. Confirm the specifications.

Products represented in this catalog are designed for use in compressed air applications only (including vacuum), unless otherwise indicated.

Do not use the product outside their design parameters.

Please contact SMC when using the products in applications other than compressed air (including vacuum).

Mounting

Warning

1. Instruction manual

Install the products and operate them only after reading the instruction manual carefully and understanding its contents. Also keep the manual where it can be referred to as necessary.

2. Securing the space for maintenance

When installing the products, please allow access for maintenance.

3. Tightening torque

When installing the products, please follow the listed torque specifications.

Piping

Caution

1. Before piping

Make sure that all debris, cutting oil, dust, etc. are removed from the piping.

2. Wrapping of pipe tape

When screwing piping or fittings into ports, ensure that chips from the pipe threads or sealing material do not get inside the piping. Also, when the pipe tape is used, leave 1.5 to 2 thread ridges exposed at the end of the threads.

Air Supply

Warning

1. Operating fluid

Please consult with SMC when using the product in applications other than compressed air (including vacuum).

Regarding products for general fluid, please ask SMC about applicable fluids.

2. Install an air dryer, aftercooler, etc.

Excessive condensate in a compressed air system may cause valves and other pneumatic equipment to malfunction.

Installation of an air dryer, after cooler etc. is recommended.

3. Drain flushing

If condensate in the drain bowl is not emptied on a regular basis, the bowl will over flow and allow the condensate to enter the compressed air lines.

If the drain bowl is difficult to check and remove, it is recommended that a drain bowl with the auto-drain option be installed.

For compressed air quality, refer to "Air Preparation Equipment" catalog.

4. Use clean air

If the compressed air supply is contaminated with chemicals, synthetic materials, corrosive gas, etc., it may lead to break down or malfunction.

Operating Environment

Warning

1. Do not use in environments where the product is directly exposed to corrosive gases, chemicals, salt water, water or steam.

2. Do not expose the product to direct sunlight for an extended period of time.

3. Do not use in a place subject to heavy vibrations and/or shocks.

4. Do not mount the product in locations where it is exposed to radiant heat.

Maintenance

Warning

1. Maintenance procedures are outlined in the operation manual.

Not following proper procedures could cause the product to malfunction and could lead to damage to the equipment or machine.

2. Maintenance work

If handled improperly, compressed air can be dangerous.

Assembly, handling and repair of pneumatic systems should be performed by qualified personnel only.

3. Drain flushing

Remove drainage from air filters regularly. (Refer to the specifications.)

4. Shut-down before maintenance

Before attempting any kind of maintenance make sure the supply pressure is shut of and all residual air pressure is released from the system to be worked on.

5. Start-up after maintenance and inspection

Apply operating pressure and power to the equipment and check for proper operation and possible air leaks. If operation is abnormal, please verify product set-up parameters.

6. Do not make any modifications to be product.

Do not take the product apart.

Quality Assurance Information (ISO 9001, ISO 14001)

Reliable quality of products in the global market

To enable our customers throughout the world to use our products with even greater confidence, SMC has obtained certification for international standards “ISO 9001” and “ISO 14001”, and created a complete structure for quality assurance and environmental controls. SMC products pursue to meet its customers’ expectations while also considering company’s contribution in society.

Quality management system ISO 9001

This is an international standard for quality control and quality assurance. SMC has obtained a large number of certifications in Japan and overseas, providing assurance to our customers throughout the world.



Environmental management system ISO 14001

This is an international standard related to environmental management systems and environmental inspections. While promoting environmentally friendly automation technology, SMC is also making diligent efforts to preserve the environment.



SMC’s quality control system



Quality policies



Quality control activities

SMC Product Conforming to Inter

SMC products complying with EN/ISO, CSA/UL standards are supporting



The CE mark indicates that machines and components meet essential requirements of all the EC Directives applied.

It has been obligatory to apply CE marks indicating conformity with EC Directives when machines and components are exported to the member Nations of the EU.

Once "A manufacturer himself" declares a product to be safe by means of CE marking (declaration of conformity by manufacturer), free distribution inside the member Nations of the EU is permissible.

■ CE Mark

SMC provides CE marking to products to which EMC and Low Voltage Directives have been applied, in accordance with CETOP (European hydraulics and pneumatics committee) guide lines.

■ As of February 1998, the following 18 countries will be obliged to conform to CE mark legislation

Iceland, Ireland, United Kingdom, Italy, Austria, Netherlands, Greece, Liechtenstein, Sweden, Spain, Denmark, Germany, Norway, Finland, France, Belgium, Portugal, Luxembourg

■ EC Directives and Pneumatic Components

• Machinery Directive

The Machinery Directive contains essential health and safety requirements for machinery, as applied to industrial machines e.g. machine tools, injection molding machines and automatic machines. Pneumatic equipment is not specified in Machinery Directive. However, the use of SMC products that are certified as conforming to EN Standards, allows customers to simplify preparation work of the Technical Construction File required for a Declaration of Conformity.

• Electromagnetic Compatibility (EMC) Directive

The EMC Directive specifies electromagnetic compatibility. Equipment which may generate electromagnetic interference or whose function may be compromised by electromagnetic interference is required to be immune to electromagnetic affects (EMS/immunity) without emitting excessive electromagnetic affects (EMI/emission).

• Low Voltage Directive

This directive is applied to products, which operate above 50 VAC to 1000 VAC and 75 VDC to 1500 VDC operating voltage, and require electrical safety measures to be introduced.

• Simple Pressure Vessels Directive

This directive is applied to welded vessels whose maximum operating pressure (PS) and volume of vessel (V) exceed 50 bar/L. Such vessels require EC type examination and then CE marking.

national Standards

you to comply with EC directives and CSA/UL standards.



■ CSA Standards & UL Standards

UL and CSA standards have been applied in North America (U.S.A. and Canada) symbolizing safety of electric products, and are defined to mainly prevent danger from electric shock or fire, resulting from trouble with electric products. Both UL and CSA standards are acknowledged in North America as the first class certifying body. They have a long experience and ability for issuing product safety certificate. Products approved by CSA or UL standards are accepted in most states and governments beyond question.

Since CSA is a test certifying body as the National Recognized Testing Laboratory (NRTL) within the jurisdiction of Occupational Safety and Health Administration (OSHA), SMC was tested for compliance with CSA Standards and UL Standards at the same time and was approved for compliance with the two Standards. The above CSA NRTL/C logo is described on a product label in order to indicate that the product is approved by CSA and UL Standards.

■ TSSA (MCCR) Registration Products

TSSA is the regulation in Ontario State, Canada. The products that the operating pressure is more than 5 psi (0.03 MPa) and the piping size is bigger than 1 inch. fall into the scope of TSSA regulation.

Products conforming to CE Standard



With CE symbol for simple visual recognition

In this catalog each accredited product series is indicated with a CE mark symbol. However, in some cases, every available models may not meet CE compliance. Please visit our web site for the latest selection of available models with CE mark.

<http://www.smcworld.com>

SMC's Global Service Network

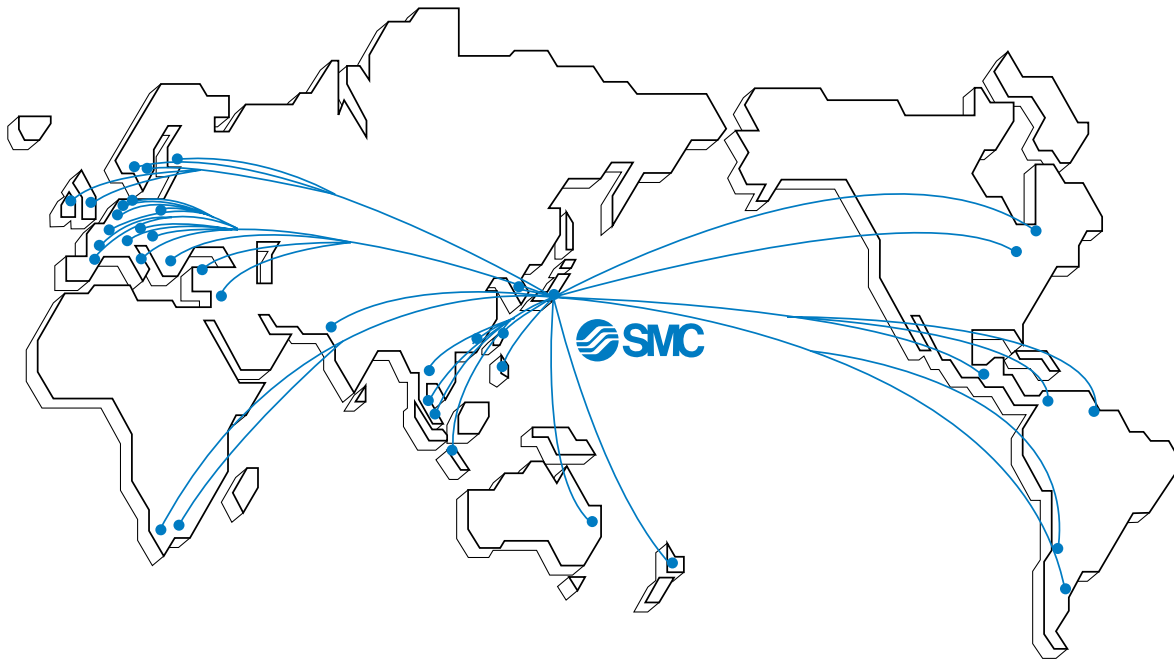

America

U.S.A. **SMC Corporation of America**

3011 North Franklin Road Indianapolis, IN 46226, U.S.A.
TEL: 317-899-4440 FAX: 317-899-3102

CANADA **SMC Pneumatics (Canada) Ltd.**

6768 Financial Drive Mississauga, Ontario, L5N 7J6 Canada
TEL: 905-812-0400 FAX: 905-812-8686

MEXICO **SMC Corporation (Mexico), S.A. DE C.V.**

Carr. Silao-Trejo K.M. 2.5 S/N, Predio San Jose del Duranzo
C.P. 36100, Silao, Gto., Mexico
TEL: 472-72-2-55-00 FAX: 472-72-2-59-44/2-59-46

CHILE **SMC Pneumatics (Chile) S.A.**

Av. La Montaña 1,115 km. 16,5 P. Norte Parque
Industrial Valle Grande, Lampa Santiago, Chile
TEL: 02-270-8600 FAX: 02-270-8601

ARGENTINA **SMC Argentina S.A.**

Teodoro Garcia 3860 (1427) Buenos Aires, Argentina
TEL: 011-4555-5762 FAX: 011-4555-5762

BOLIVIA **SMC Pneumatics Bolivia S.R.L.**

Avenida Beni Numero 4665
Santa Cruz de la Sierra-Casilla de Correo 2281, Bolivia
TEL: 591-3-3428383 FAX: 591-3-3449900

VENEZUELA **SMC Neumatica Venezuela S.A.**

Apartado 40152, Avenida Nueva Granada, Edificio Wanlac,
Local 5, Caracas 1040-A, Venezuela
TEL: 2-632-1310 FAX: 2-632-3871

PERU (Distributor) **IMPECO Automatizacion Industrial S.A.**

AV. Canevaro 752, Lince, Lima, Peru
TEL: 1-471-6002 FAX: 1-471-0935

URUGUAY (Distributor) **BAKO S.A.**

Galicia 1650 esq. Gaboto C.P. 11200, Montevideo, Uruguay
TEL: 2-401-6603 FAX: 2-409-4306

BRAZIL **SMC Pneumaticos Do Brasil Ltda.**

Rua. Dra. Maria Fidelis, nr. 130, Jardim Piraporinha-Diadema-S.P.
CEP: 09950-350, Brasil
TEL: 11-4051-1177 FAX: 11-4071-6636

COLOMBIA (Distributor) **Airmatic Ltda.**

Calle 18 69-05 Apart. Aereo 081045 Santa Fe de Bogotá, Colombia
TEL: 1-424-9240 FAX: 1-424-9260

Europe

U.K. **SMC Pneumatics (U.K.) Ltd.**

Vincent Avenue, Crownhill, Milton Keynes, MK8 0AN, Buckinghamshire, U.K.
TEL: 01908-563888 FAX: 01908-561185

GERMANY **SMC Pneumatik GmbH**

Boschring 13-15 D-63329 Egelsbach, Germany
TEL: 06103-4020 FAX: 06103-402139

ITALY **SMC Italia S.p.A.**

Via Garibaldi 62 I-20061 Carugate Milano, Italy
TEL: 02-9271365 FAX: 02-9271365

FRANCE **SMC Pneumatique S.A.**

1 Boulevard de Strasbourg, Parc Gustave Eiffel, Bussy Saint Georges, F-77600
Marne La Vallee Cedex 3 France
TEL: 01-64-76-10-00 FAX: 01-64-76-10-10

SWEDEN **SMC Pneumatics Sweden AB**

Ekhagsvägen 29-31, S-141 05 Huddinge, Sweden
TEL: 08-603-07-00 FAX: 08-603-07-10

SWITZERLAND **SMC Pneumatik AG**

Dorfstrasse 7, Postfach 117, CH-8484 Weisslingen, Switzerland
TEL: 052-396-3131 FAX: 052-396-3191

AUSTRIA **SMC Pneumatik GmbH (Austria)**

Girakstrasse 8, A-2100 Korneuburg, Austria
TEL: 0-2262-6228-0 FAX: 0-2262-62285

SPAIN **SMC España, S.A.**

Zuazobidea 14 Pol. Ind. Júndiz 01015 Vitoria, Spain
TEL: 945-184-100 FAX: 945-184-510

IRELAND **SMC Pneumatics (Ireland) Ltd.**

2002 Citywest Business Campus, Naas Road, Saggart, Co. Dublin, Ireland
TEL: 01-403-9000 FAX: 01-466-0385

NETHERLANDS (Associated company) **SMC Pneumatics BV**

De Ruyterkade 120, NL-1011 AB Amsterdam, Netherlands
TEL: 020-5318888 FAX: 020-5318880

GREECE (Distributor) **S.Parianopoulos S.A.**

7, Konstantinoupoleos Street 11855 Athens, Greece
TEL: 01-3426076 FAX: 01-3455578

DENMARK **SMC Pneumatik A/S**

Knudsminde 4 B DK-8300
Odder, Denmark
TEL: 70252900 FAX: 70252901

Europe

FINLAND **SMC Pneumatics Finland OY**

PL72, Tiistinniityntie 4, SF-02231 ESP00, Finland
TEL: 09-8595-80 FAX: 09-8595-8595

NORWAY **SMC Pneumatics Norway A/S**

Vollsveien 13C, Granfoss Næringspark N-1366 LYSAKER, Norway
TEL: 67-12-90-20 FAX: 67-12-90-21

BELGIUM (Distributor) **SMC Pneumatics N.V./S.A.**

Nijverheidsstraat 20 B-2160 Wommelgem Belguim
TEL: 03-355-1464 FAX: 03-355-1466

POLAND **SMC Industrial Automation Polska Sp.z.o.o.**

ul. Konstruktorska 11A, PL-02-673 Warszawa, Poland
TEL: 022-548-5085 FAX: 022-548-5087

TURKEY (Distributor) **Entek Pnömatik San.ve Tic. Ltd. Sti**

Perpa Tic. Merkezi Kat:11 No.1625 80270 Okmeydani Istanbul, Türkiye
TEL: 0212-221-1512 FAX: 0212-221-1519

RUSSIA **SMC Pneumatik LLC.**

36/40 Sredny prospect V.O. St. Petersburg 199004, Russia
TEL: 812-118-5445 FAX: 812-118-5449

CZECH **SMC Industrial Automation CZ s.r.o.**

Hudcova 78a, CZ-61200 Brno, Czech Republic
TEL: 05-4121-8034 FAX: 05-4121-8034

HUNGARY **SMC Hungary Ipari Automatizálási kft.**

Budafoki ut 107-113 1117 Budapest
TEL: 01-371-1343 FAX: 01-371-1344

ROMANIA **SMC Romania S.r.l.**

Str. Frunzei, Nr. 29, Sector 2, Bucharest, Romania
TEL: 01-3205111 FAX: 01-3261489

SLOVAKIA **SMC Priemyselná automatizácia, s.r.o.**

Nova 3, SK-83103 Bratislava
TEL: 02-4445-6725 FAX: 02-4445-6028

SLOVENIA **SMC Industrijska Avtomatila d.o.o.**

Grajski trg 15, SLO- 8360 Zuzemberk, Slovenia
TEL: 07388-5240 FAX: 07388-5249

LATVIA **SMC Pneumatics Latvia SIA**

Šmerļa ielā 1-705, Rīga LV-1006
TEL: 777 94 74 FAX: 777 94 75

SOUTH AFRICA (Distributor) **Hyflo Southern Africa (Pty.) Ltd.**

P.O.Box 240 Paardeneiland 7420 South Africa
TEL: 021-511-7021 FAX: 021-511-4456

EGYPT (Distributor) **Saadani Trading & Ind. Services**

15 Sebaai Street, Miami 21411 Alexandria, Egypt
TEL: 3-548-50-34 FAX: 3-548-50-34

Oceania/Asia

AUSTRALIA **SMC Pneumatics (Australia) Pty.Ltd.**

14-18 Hudson Avenue Castle Hill NSW 2154, Australia
TEL: 02-9354-8222 FAX: 02-9894-5719

NEW ZEALAND **SMC Pneumatics (New Zealand) Ltd.**

8C Sylvia Park Road Mt.Wellington Auckland, New Zealand
TEL: 09-573-7007 FAX: 09-573-7002

TAIWAN **SMC Pneumatics (Taiwan) Co.,Ltd.**

17, Lane 205, Nansan Rd., Sec.2, Luzhu-Hsiang, Taoyuan-Hsien, TAIWAN
TEL: 03-322-3443 FAX: 03-322-3387

HONG KONG **SMC Pneumatics (Hong Kong) Ltd.**

29/F, Clifford Centre, 778-784 Cheung, Sha Wan Road, Lai Chi Kok, Kowloon, Hong Kong
TEL: 2744-0121 FAX: 2785-1314

SINGAPORE **SMC Pneumatics (S.E.A.) Pte. Ltd.**

89 Tuas Avenue 1, Jurong Singapore 639520
TEL: 6861-0888 FAX: 6861-1889

PHILIPPINES **SHOKETSU SMC Corporation**

Unit 201 Common Goal Tower, Madrigal Business Park, Ayala Alabang Muntinlupa, Philippines
TEL: 02-8090565 FAX: 02-8090586

MALAYSIA **SMC Pneumatics (S.E.A.) Sdn. Bhd.**

Lot 36 Jalan Delima1/1, Subang Hi-Tech Industrial Park, Batu 3 40000 Shah Alam Selangor, Malaysia
TEL: 03-56350590 FAX: 03-56350602

SOUTH KOREA **SMC Pneumatics Korea Co., Ltd.**

Woolim e-BIZ Center (Room 1008), 170-5, Guro-Dong, Guro-Gu, Seoul, 152-050, South Korea
TEL: 02-3219-0700 FAX: 02-3219-0702

CHINA **SMC (China) Co., Ltd.**

7 Wan Yuan St. Beijing Economic & Technological Development Zone 100176, China
TEL: 010-67882111 FAX: 010-67881837

THAILAND **SMC Thailand Ltd.**

134/6 Moo 5, Tiwanon Road, Bangkadi, Amphur Muang, Patumthani 12000, Thailand
TEL: 02-963-7099 FAX: 02-501-2937

INDIA **SMC Pneumatics (India) Pvt. Ltd.**

D-107 to 112, Phase-2, Extension, Noida, Dist. Gautaim Budh Nagar, U.P. 201 305, India
TEL: (0120)-4568730 FAX: 0120-4568933

INDONESIA (Distributor) **P.T. Riyadi Putera Makmur**

Jalan Hayam Wuruk Komplek Glodok Jaya No. 27-28 Jakarta 11180 Indonesia
TEL: 021-625 5548 FAX: 021-625 5888

PAKISTAN (Distributor) **Jubilee Corporation**

First Floor Mercantile Centre, Newton Road Near Boulton Market P.O. Box 6165 Karachi 74000 Pakistan
TEL: 021-243-9070/8449 FAX: 021-241-4589

ISRAEL (Distributor) **Baccara Automation Control**

Kvutza Geva 18915 Israel
TEL: 04-653-5960 FAX: 04-653-1445

SAUDI ARABIA (Distributor) **Assaggaff Trading Est.**

P.O. Box 3385 Al-Amir Majed Street, Jeddah-21471, Saudi Arabia
TEL: 02-6761574 FAX: 02-6708173