

e-Rodless Actuator

Series *E-MY2C/H/HT*



Having both the operationability of an air cylinder and the speed controllability of an electric actuator

New
Actuator concept

e-Actuator

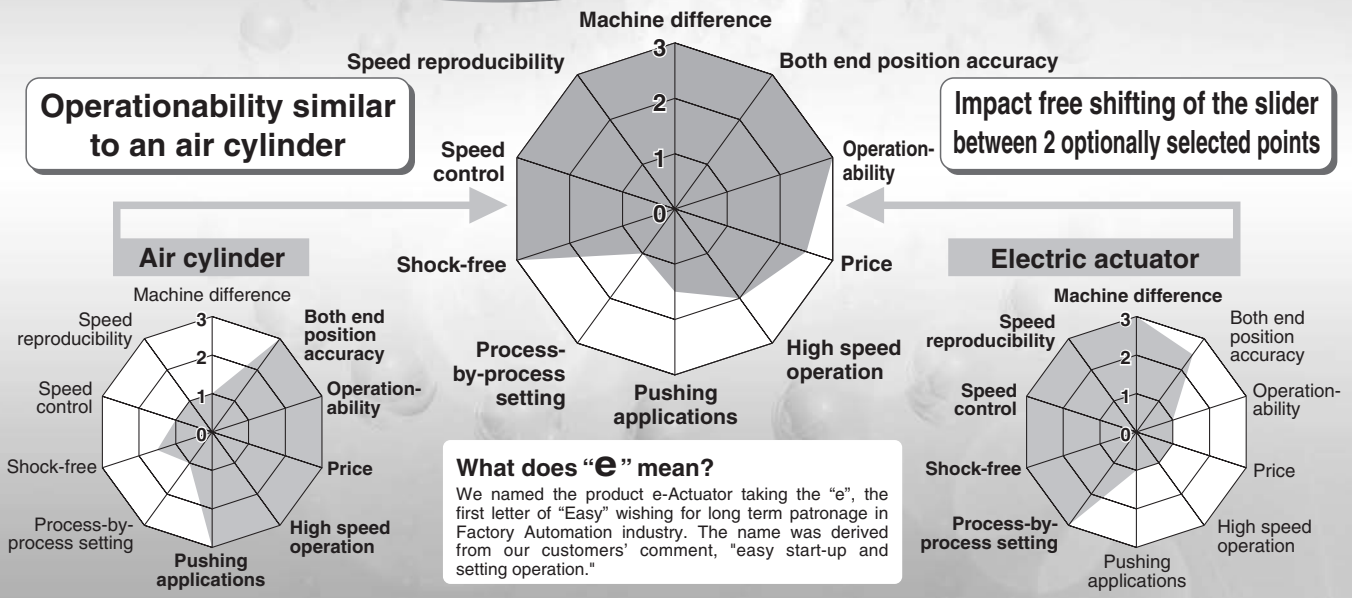

Cam follower guide type
Series *E-MY2C*

P.1125



Linear guide single axis type
Series *E-MY2H*

P.1131



Linear guide double axis type
Series *E-MY2HT*

P.1131



LJ1

LG1

LTF

LC1

LC7

LC8

LXF

LXP

LXS

LC6

LZ

LC3F2

X

D-

E-MY

1 2 3 Realizing electric controllability similar to that of an air cylinder by 3 step operation

1

Stroke adjustment

① Movable stroke adjusting unit
② Small incremental adjustments can be made by using an adjusting bolt.

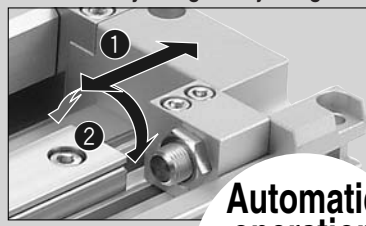

Automatic operation

Operable by the same signals (PLC) as the solenoid valve.

2

Stroke learning

Press STROKE STUDY switch.



3

Speed and acceleration setting

Adjust SPEED, ACCELERATION.

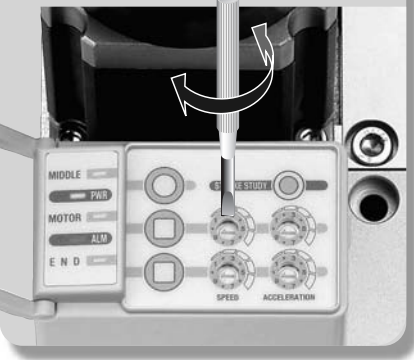

Locking Functions

Settings for speed/acceleration can be locked.
If the speed/acceleration switch is changed in the middle of locking, the alarm light will blink. However, the motion will continue in accordance with the preprogrammed settings.

* Settings for locking a stroke and intermediate position are not applicable.

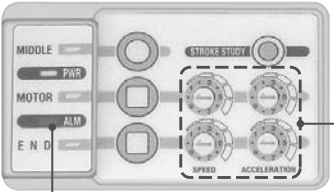

Speed / Acceleration switch

Indicator light for alarm

Remote Control Type

Easy to reset after installation as a result of the remote controller.
Suited for installing where it is difficult to reach because the controller can be operated in an easily accessible location.

- Cable length is selectable from 1 m, 3 m and 5 m.
- Improvement in the maximum operating temperature from 40°C to 50°C (Actuator unit only)
- Mounting method can be selected among 3 types.

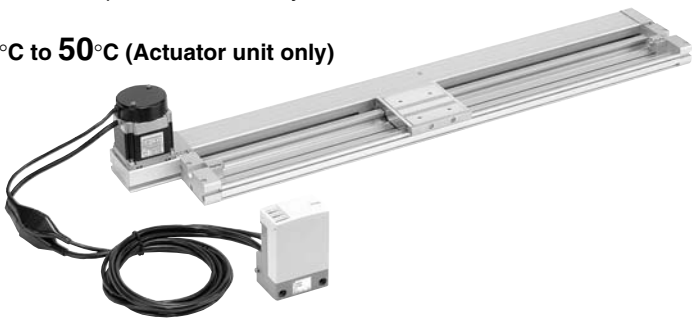
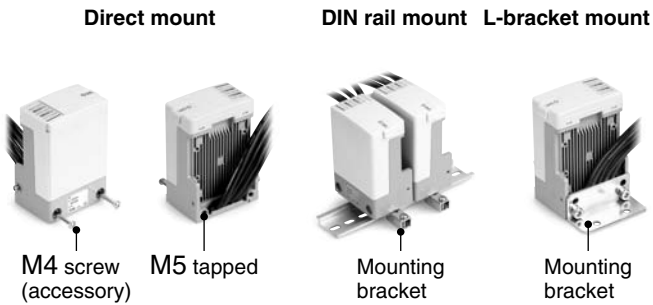

Intermediate Stop

3-point stoppable type

(2-point for both ends and 1-point for an intermediate stop)

One intermediate stop is possible beside stops at both ends.

5-point stoppable type

(2-point for both ends and 3-point for an intermediate stop)

5-point positioning is possible at any preferred locations.

3-point
stoppable
type

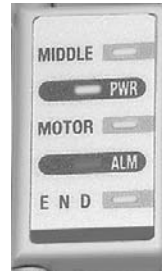

5-point
stoppable
type (with
streamer)

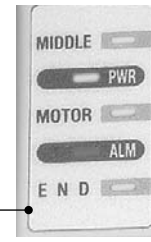

Stop Functions by External Inputs (5-point stoppable type only)

Stop command by an external input such as a PLC or PC makes it possible to decelerate or stop a slider (as programmed).

Application example 1

Quick start-up is possible after stopping.

Stop method	Stop by external inputs	Emergency stop
Stopping acceleration (deceleration speed)	Value of a switch for setting acceleration	4.9 m/s ²
Initial motion speed after stopping	Value of a switch for speed	50 mm/s

* Settings for emergency acceleration and speed cannot be changed.

Repeatability of stop functions by external stop

Travelling speed (mm/s)	100	500	1000
Repeatability (mm)	±0.5	±1.0	±2.0

Note) The valves shown are to be used as a selection guide and are not guaranteed.

Application example 2

Signal from auto switches on the e-rodless cylinder can make it decelerate or stop.

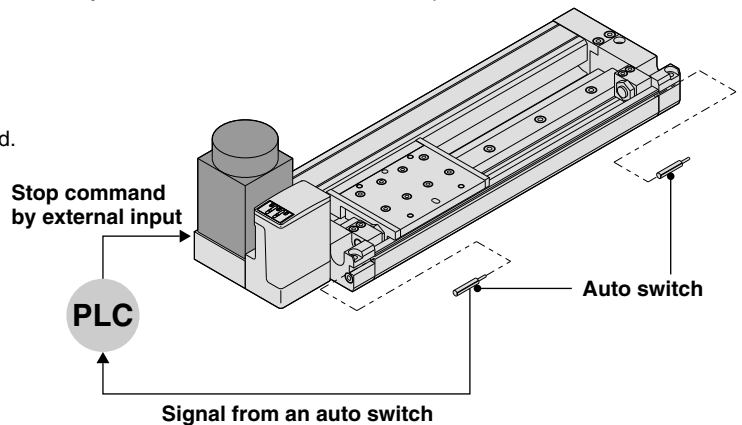

Easy Maintenance

The actuating part and the guide unit can be separated from the cylinder body.

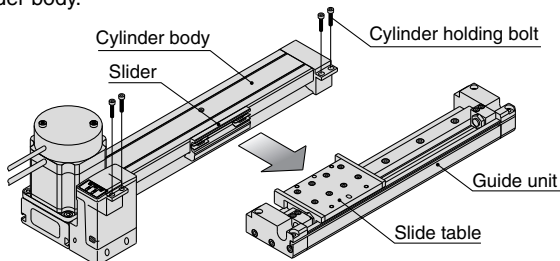

Motor Placement: Mounting position of the motor is user selectable and can either be on the top, bottom, left, or right of the actuator.

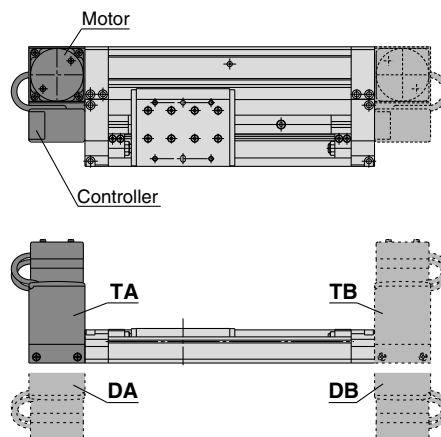

Motor placement

TA	On the top, Standard
DA	On the bottom, Standard
TB	On the top, Symmetric
DB	On the bottom, Symmetric

The following are steps for selecting the E-MY2 series best suited for your application.

Selection Flow Chart

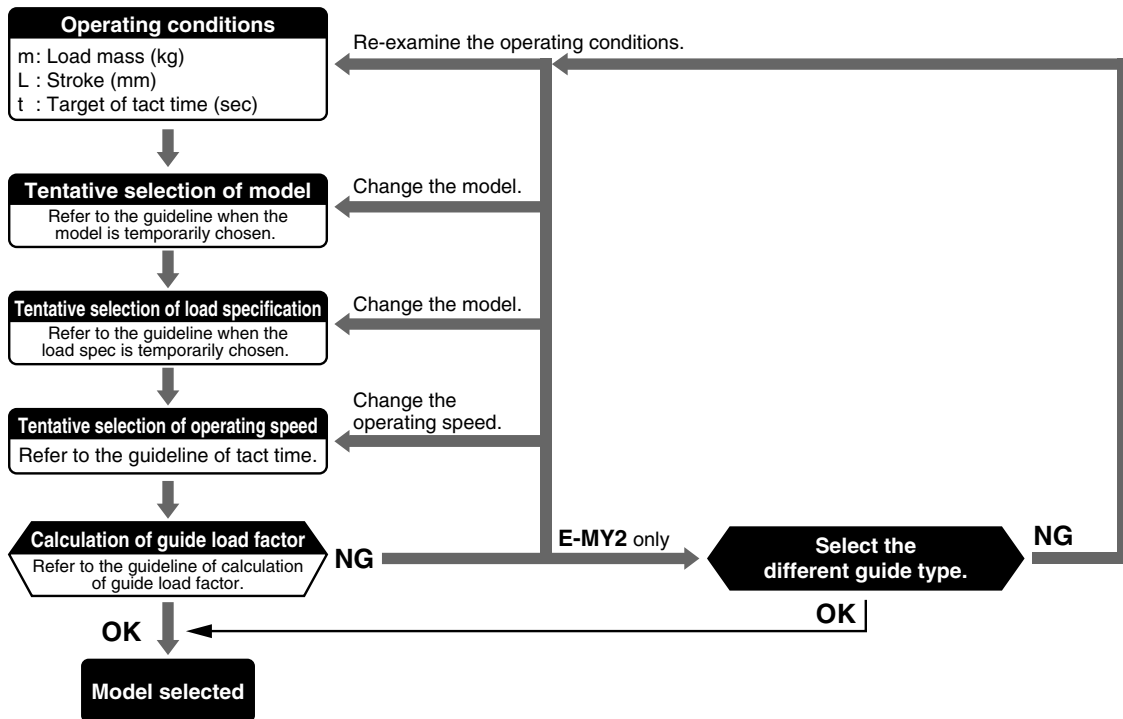

Guideline for Tentative Model Selection

Model	Type	Guideline for tentative model selection						Note
		Stroke accuracy	Use of external guide	Direct loaded (Horizontal)	Table ^{Note)} accuracy	Direct mount (Wall mounting)	Load resistance / Moment resistance	
E-MY2B	Basic type	◎	◎	○	△	△	△	Light-load transfer; combining with another guide; stroke accuracy is required.
E-MY2C	Cam follower guide type	◎	×	◎	◎	○	○	Workpiece direct mounting; table and stroke accuracy are required.
E-MY2H	Linear guide single axis type	◎	×	◎	◎	◎	○	Workpiece direct mounting without restriction of mounting direction; table and stroke accuracy are required.
E-MY2HT	Linear guide double axis type	◎	×	◎	◎	◎	◎	Workpiece direct mounting without restriction of mounting direction; table and stroke accuracy are required especially when a heavy load or moment is applied.

◎ Most suitable ○ Suitable △ Usable × Not recommended
 Note) The table accuracy means the amount of table deflection when a moment is applied.

Guideline for when the load spec is temporarily chosen.

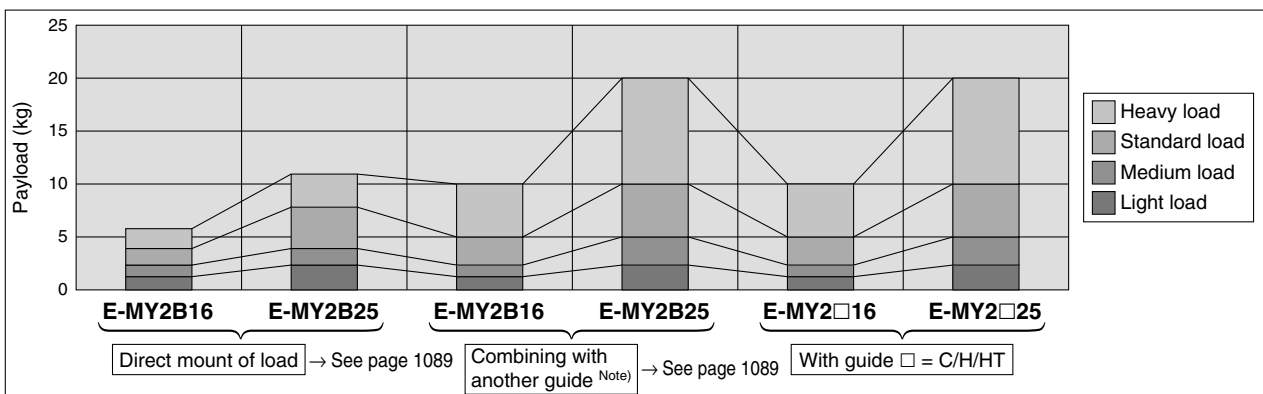

Note) Friction coefficient for combining with another guide is 0.1 or less.

Model Selection

Guide Tact Time

Heavy Load (2.45 m/s²)

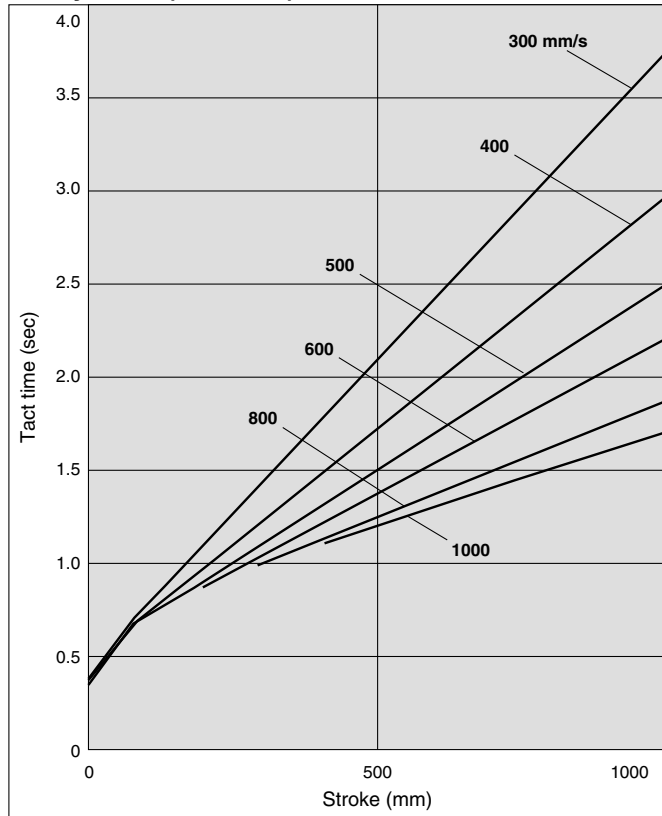

Standard Load (4.90 m/s²)

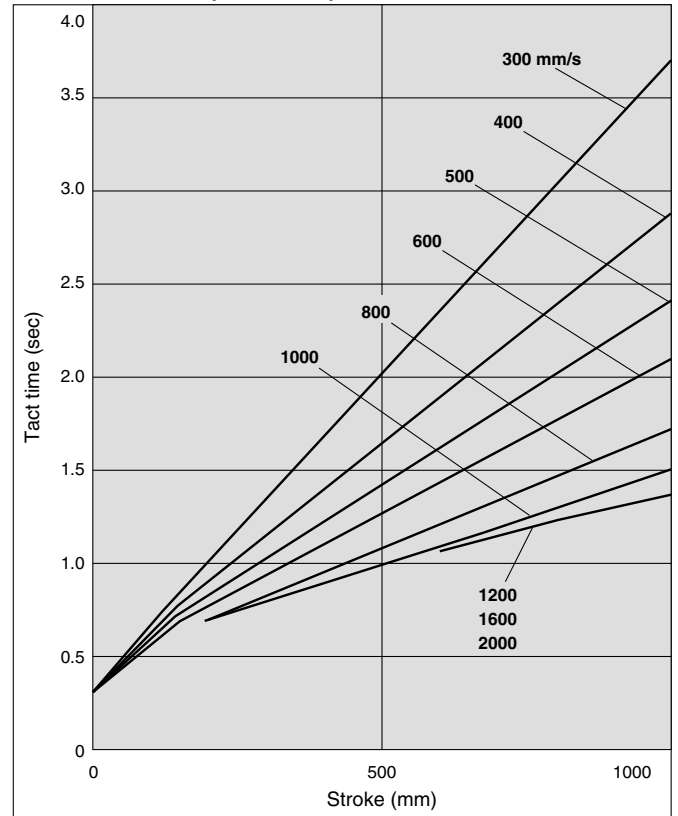

Medium Load (9.80 m/s²)

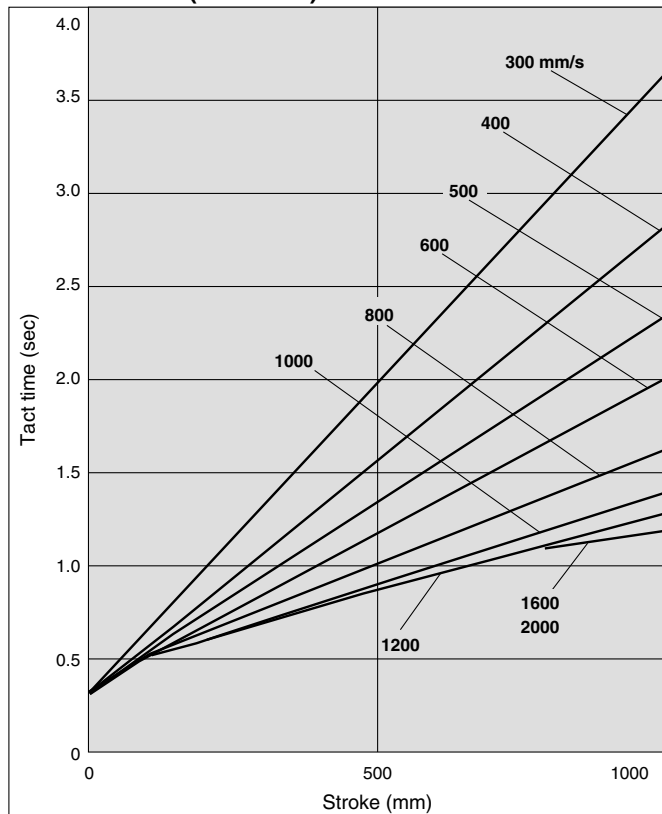

Light Load (19.60 m/s²)

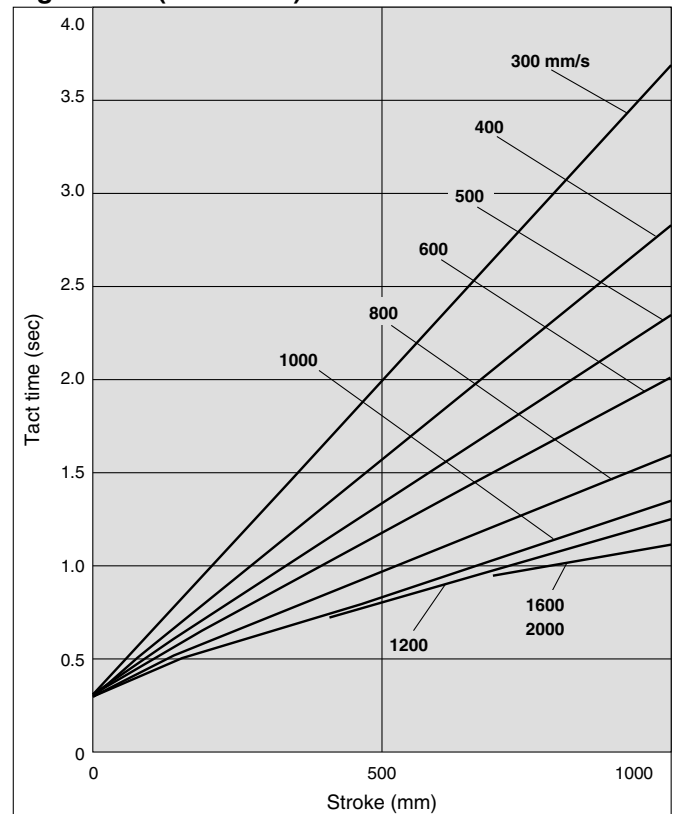

LJ1

LG1

LTF

LC1

LC7

LC8

LXF

LXP

LXS

LC6

LZ

LC3F2

X

D-

E-MY

Note) Tact time may vary depending on the load mass or sliding resistance and thus value is not guaranteed.

Series E-MY2

Model Selection 2

The following are steps for selecting the E-MY2 series best suited for your application.

Types of Moment Applied to Rodless Cylinders

Multiple moments may be generated depending on the mounting orientation, load, and position of the center of gravity.

Coordinates and moments

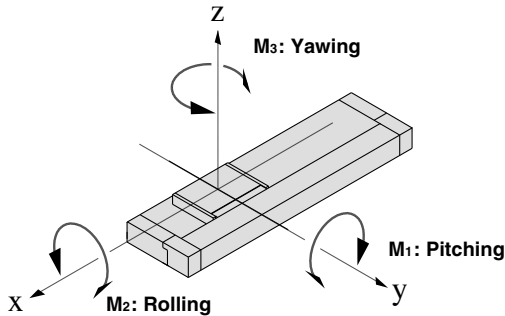

Dynamic moment

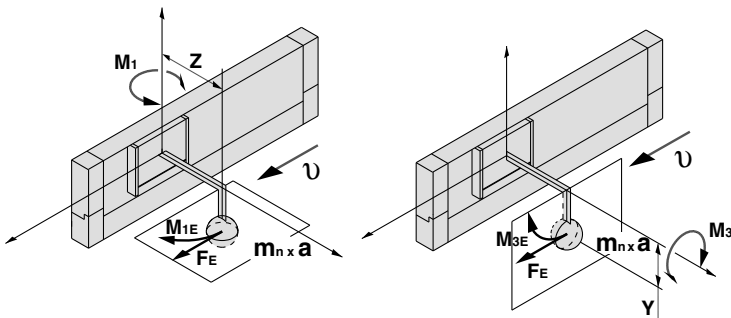

a : Set acceleration degree, v : Set speed

Mounting orientation	Horizontal mounting	Ceiling mounting	Wall mounting
Dynamic load (F_E)	$m_n \times a$		
Dynamic moment		$\frac{1}{3} \times F_E \times Z$	
M_{1E}	Dynamic moment M_{2E} does not occur.		
M_{2E}			
M_{3E}		$\frac{1}{3} \times F_E \times Y$	

Note) Regardless of the mounting orientation, dynamic moment is calculated with the formulas above.

Static moment

Horizontal mounting

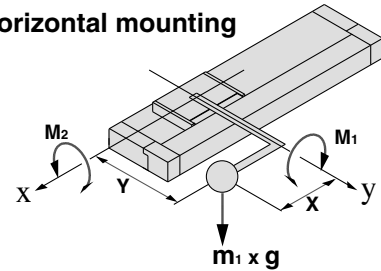

Ceiling mounting

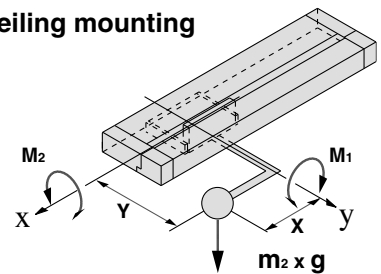

Wall mounting

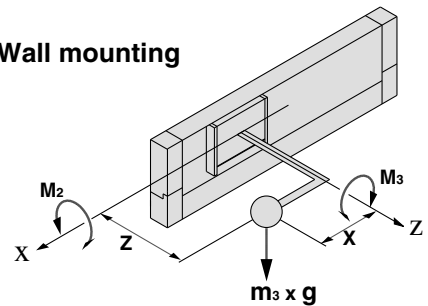

Mounting orientation	Horizontal mounting	Ceiling mounting	Wall mounting
Static load (m)	m_1	m_2	m_3
Static moment	M_1	$m_1 \times g \times X$	$m_2 \times g \times X$
	M_2	$m_1 \times g \times Y$	$m_2 \times g \times Y$
	M_3	—	$m_3 \times g \times Z$

g : Gravitational acceleration (9.8 m/s²)

Maximum Allowable Moment/Maximum Load Mass

Model	Nominal size (mm)	Maximum allowable moment (N·m)			Maximum load mass (kg)		
		M ₁	M ₂	M ₃	m ₁	m ₂	m ₃
E-MY2C	16	5	4	3.5	18	16	14
	25	13	14	10	35	35	30
E-MY2H	16	7	6	7	15	13	13
	25	28	26	26	32	30	30
E-MY2HT	16	46	55	46	20	18	18
	25	100	120	100	38	35	35

The above values are the maximum allowable values for moment and load mass. Refer to each graph regarding the maximum allowable moment and maximum load mass for a particular slide table speed.

Load mass (kg)

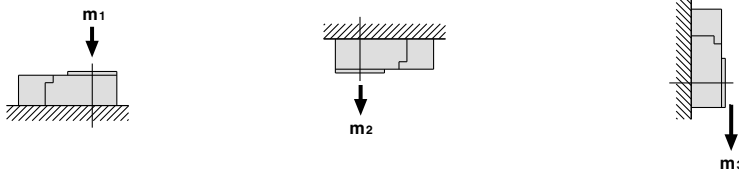

Moment (N·m)

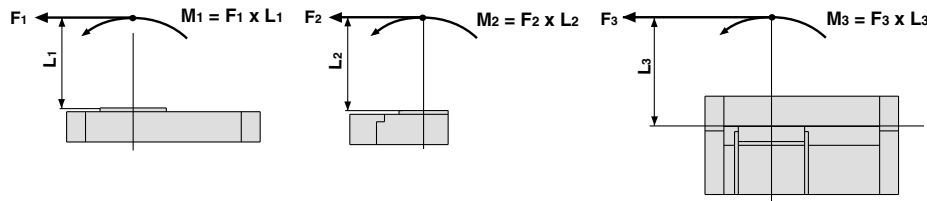

<Calculation of guide load factor>

- Maximum allowable load (1), static moment (2), and dynamic moment (at the time of acceleration/deceleration) (3) must be examined for the selection calculations.
* Calculate m max for (1) from the maximum load mass (m₁, m₂, m₃) and Mmax for (2) and (3) from the maximum allowable moment graph (M₁, M₂, M₃).

$$\text{Sum of guide load factors } \Sigma\alpha = \frac{\text{Load mass [m]}}{\text{Maximum load mass [m max]}} + \frac{\text{Static moment [M] }^{\text{Note 1)}}}{\text{Allowable static moment [Mmax]}} + \frac{\text{Dynamic moment [ME] }^{\text{Note 2)}}}{\text{Allowable dynamic moment [MEMax]}} \leq 1$$

Note 1) Moment caused by the load, etc., with actuator in resting condition.

Note 2) Moment caused by the impact load equivalent at the stroke end (at the time of collision to stopper).

Note 3) Depending on the shape of the workpiece, multiple moments may occur. When this happens, the sum of the load factors ($\Sigma\alpha$) is the total of all such moments.

2. Reference formulas [Dynamic moment at impact]

Use the following formulas to calculate dynamic moment when taking stopper impact into consideration.

m : Load mass (kg)

F : Load (N)

F_E : Load at acceleration and deceleration (N)

a : Set acceleration (m/s²)

v : Set speed (mm/s)

M : Static moment (N·m)

F_E = m·a

$$\therefore M_E = \frac{1}{3} \cdot F_E \cdot L_1 \text{ (N·m) }^{\text{Note 4)}}$$

Note 4) Average load coefficient (= $\frac{1}{3}$):

This coefficient is for averaging the dynamic moment according to service life calculations.

L₁ : Distance to the load's center of gravity (m)

M_E: Dynamic moment (N·m)

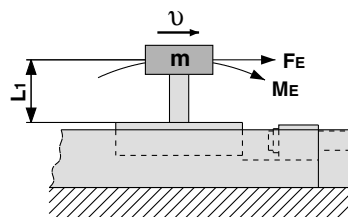

- Refer to pages 1123 and 1124 for detailed model selection procedures.

Maximum Allowable Moment

Select the moment from within the range of operating limits shown in the graphs. Note that the maximum allowable load value may sometimes be exceeded even within the operating limits shown in the graphs. Therefore, also check the allowable load for the selected conditions.

Maximum Load Mass

Select the load mass from within the range of limits shown in the graphs. Note that the maximum allowable moment value may sometimes be exceeded even within the operating limits shown in the graphs. Therefore, also check the allowable moment for the selected conditions.

The graph value is for calculating the guide load factors. Refer to the table below for actual maximum load mass. The load mass shows the motor ability.

Refer to the pages below for maximum load mass value.

E-MY2C	P.1127
E-MY2H	P.1133
E-MY2HT	

⚠ Caution

Select the required model by taking into consideration the operating condition specifications and any possible specification changes that may occur during operation. Contact the nearest sales representative for SMC's model selection software, which will help in selecting the correct model.

LJ1

LG1

LTF

LC1

LC7

LC8

LXF

LXP

LXS

LC6

LZ

LC3F2

X

D-

E-MY

Model Selection

Maximum Allowable Moment/Maximum Load Mass

Moment: E-MY2C

E-MY2C/M₁

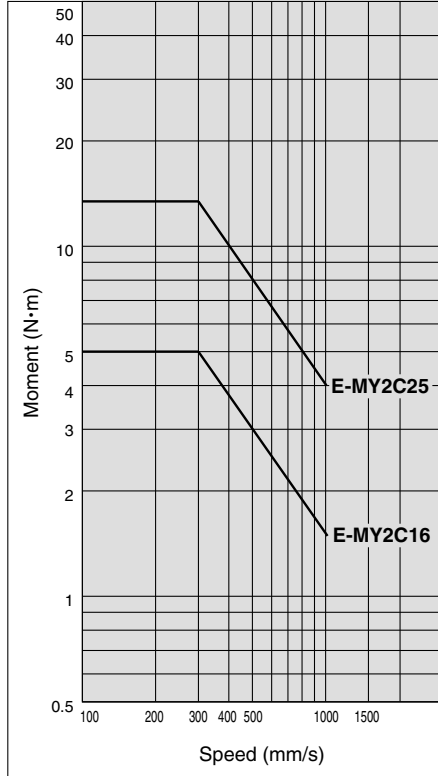

E-MY2C/M₂

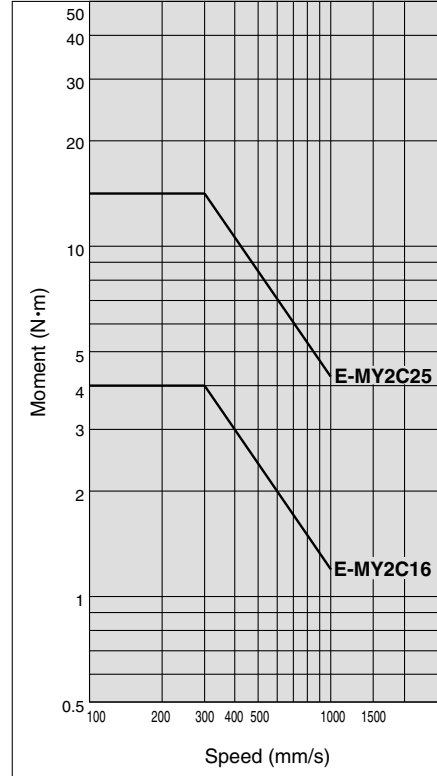

E-MY2C/M₃

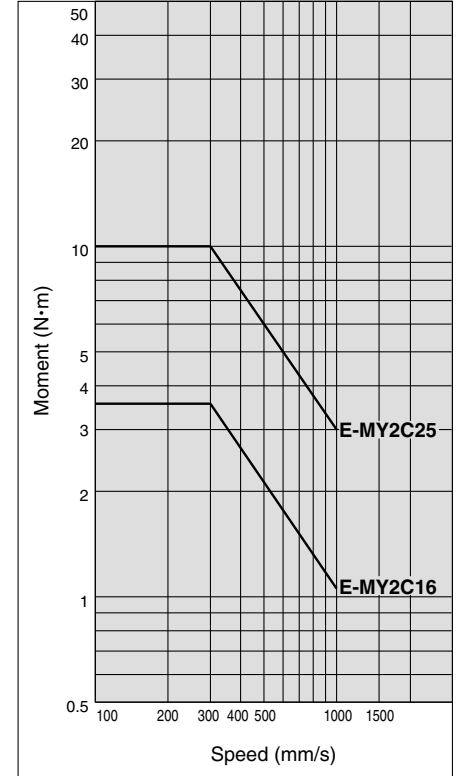

Load Mass: E-MY2C

E-MY2C/m₁

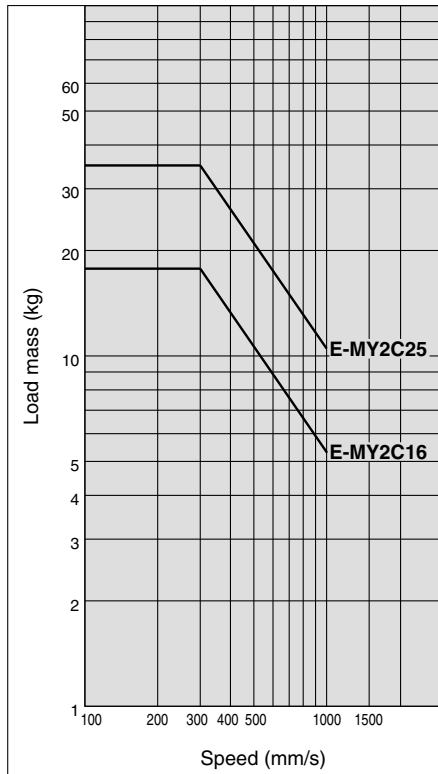

E-MY2C/m₂

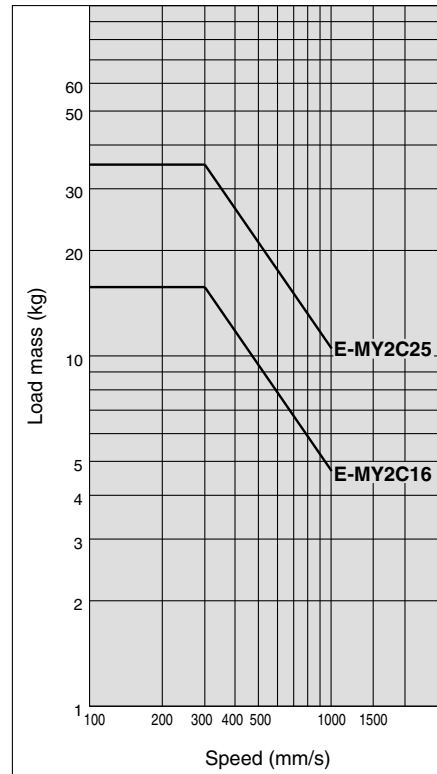

E-MY2C/m₃

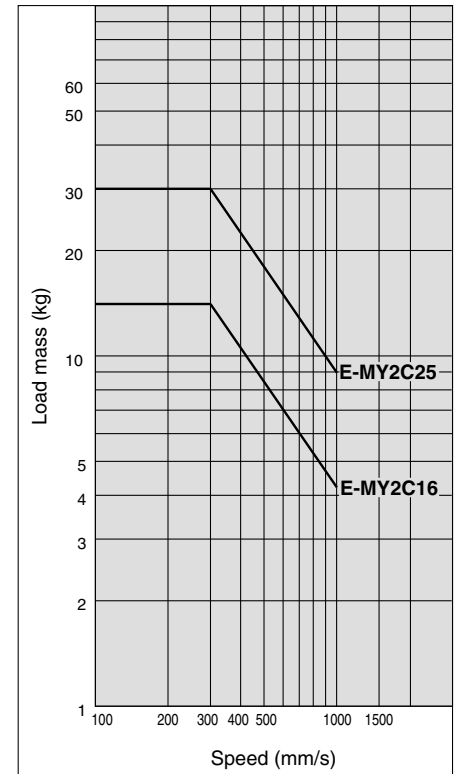

Moment: E-MY2H (Single Axis)

E-MY2H/M₁

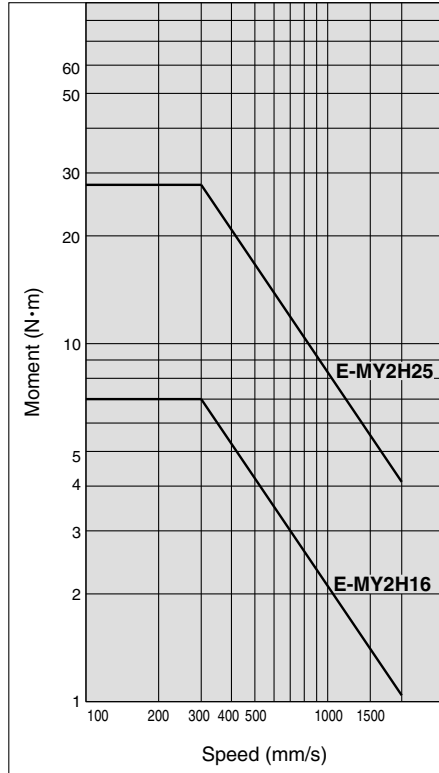

E-MY2H/M₂

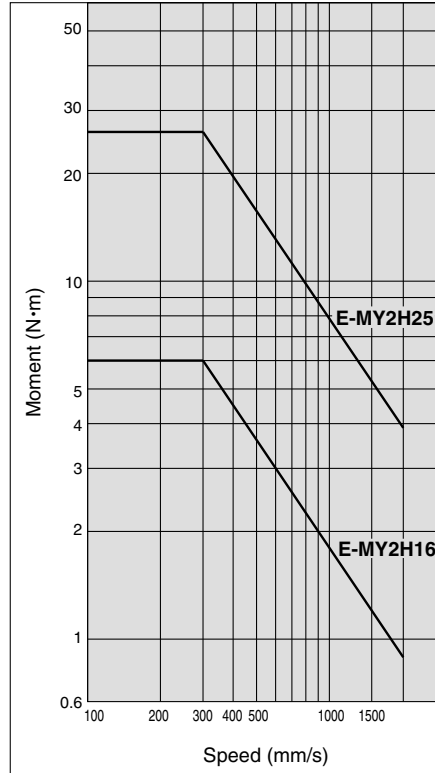

E-MY2H/M₃

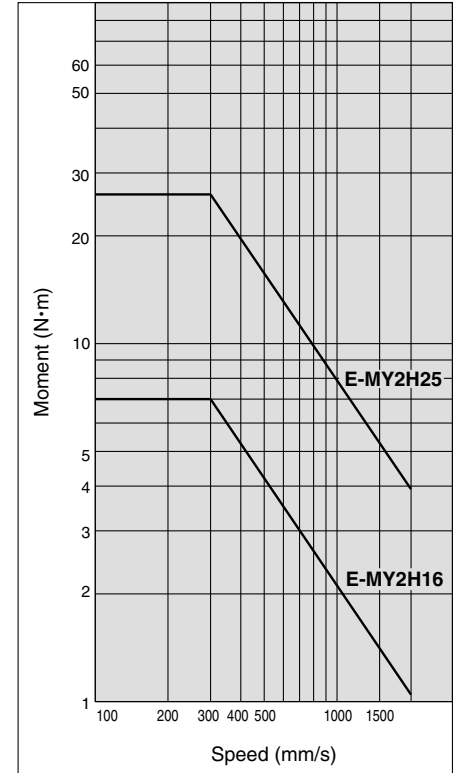

Load Mass: E-MY2H (Single Axis)

E-MY2H/m₁

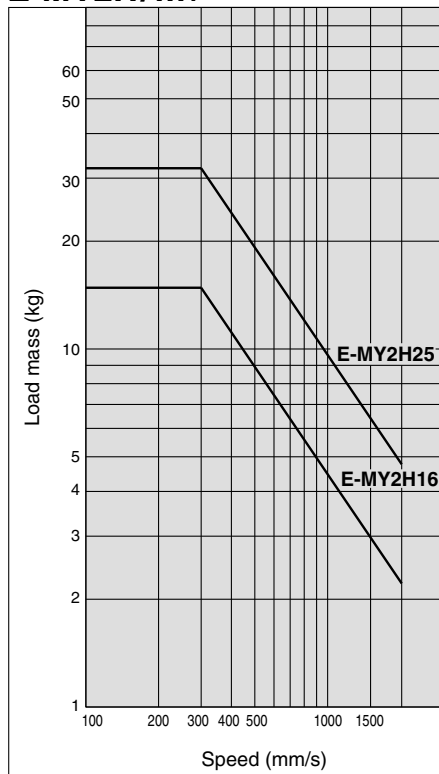

E-MY2H/m₂

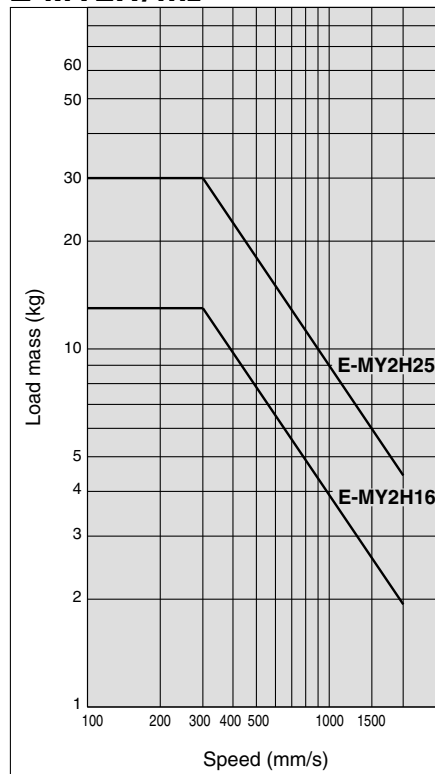

E-MY2H/m₃

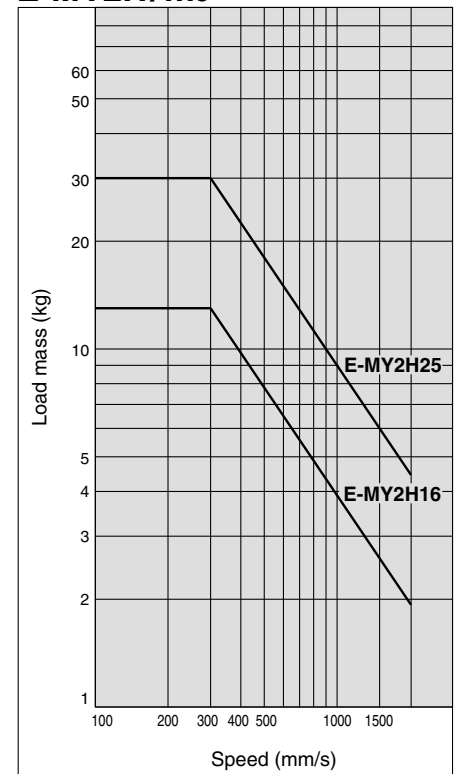

LJ1

LG1

LTF

LC1

LC7

LC8

LXF

LXP

LXS

LC6 LZ

LC3F2

X D-

E-MY

Model Selection

Maximum Allowable Moment/Maximum Load Mass

Moment: E-MY2HT (Double Axis)

E-MY2HT/M1

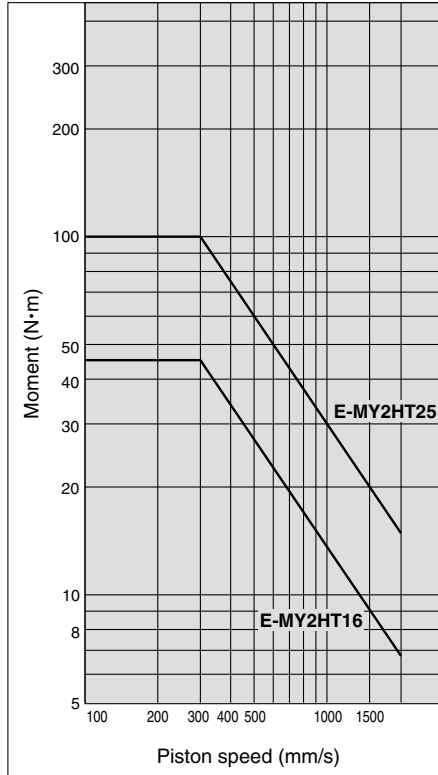

E-MY2HT/M2

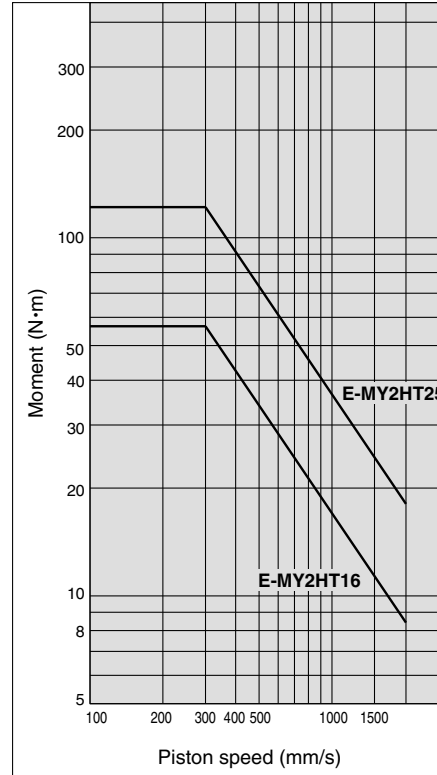

E-MY2HT/M3

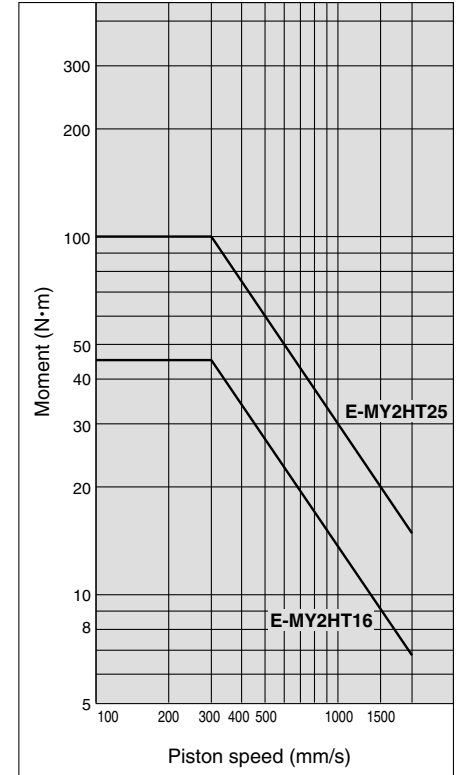

Load Mass: E-MY2HT (Double Axis)

E-MY2HT/m1

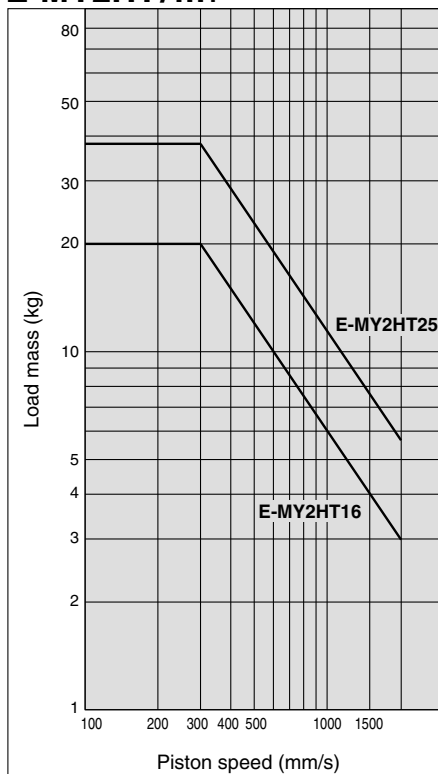

E-MY2HT/m2

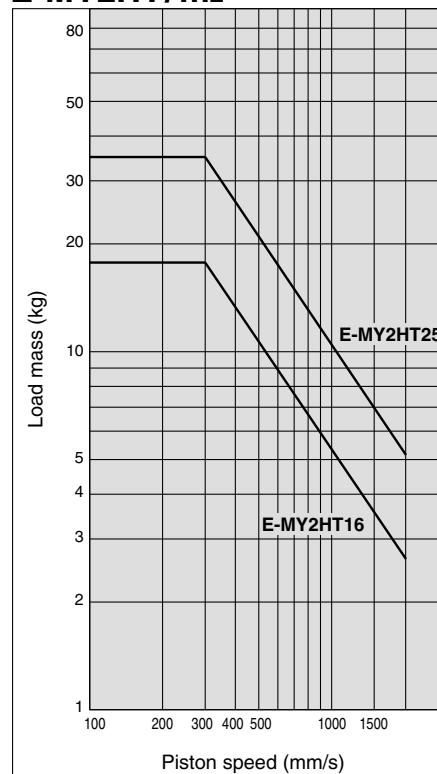

E-MY2HT/m3

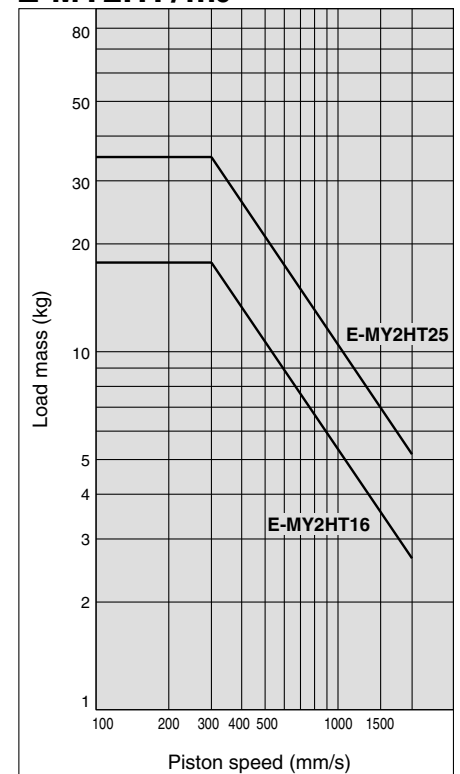

Series E-MY2

Model Selection 3

The following are steps for selecting the E-MY2 series best suited for your application.

Calculation of Guide Load Factor

1 Operating Conditions

Operating cylinder E-MY2H25-500
 Set speed v 400 mm/s Note)
 Set acceleration degree a 4.9 m/s² Note)
 Mounting orientation Wall mounting

Note) Regarding the speed and acceleration setting, select from the speed/acceleration chart on pages 1127 and 1133.

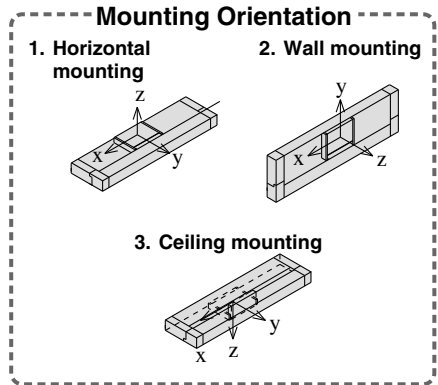
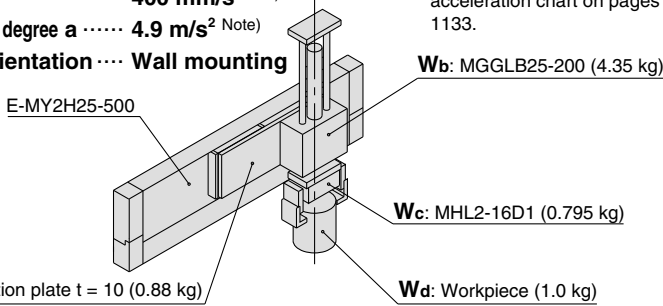

2 Load Blocking

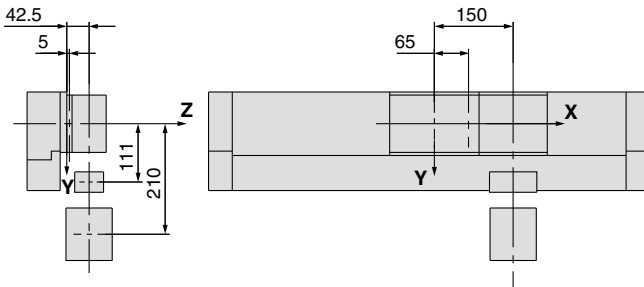

Mass and Center of Gravity for Each Workpiece

Work-piece no. (Wn)	Mass (mn)	Center of gravity		
		X-axis Xn	Y-axis Yn	Z-axis Zn
Wa	0.88 kg	65 mm	0 mm	5 mm
Wb	4.35 kg	150 mm	0 mm	42.5 mm
Wc	0.795 kg	150 mm	111 mm	42.5 mm
Wd	1.0 kg	150 mm	210 mm	42.5 mm

n = a, b, c, d

3 Calculation of Composite Center of Gravity

$$m_3 = \sum m_n$$

$$= 0.88 + 4.35 + 0.795 + 1.0 = 7.025 \text{ kg}$$

$$X = \frac{1}{m_3} \times \sum (m_n \times x_n)$$

$$= \frac{1}{7.025} (0.88 \times 65 + 4.35 \times 150 + 0.795 \times 150 + 1.0 \times 150) = 139.4 \text{ mm}$$

$$Y = \frac{1}{m_3} \times \sum (m_n \times y_n)$$

$$= \frac{1}{7.025} (0.88 \times 0 + 4.35 \times 0 + 0.795 \times 111 + 1.0 \times 210) = 42.5 \text{ mm}$$

$$Z = \frac{1}{m_3} \times \sum (m_n \times z_n)$$

$$= \frac{1}{7.025} (0.88 \times 5 + 4.35 \times 42.5 + 0.795 \times 42.5 + 1.0 \times 42.5) = 37.8 \text{ mm}$$

4 Calculation of Load Factor for Static Load

m₃: Mass

$$m_3 \text{ max (from 1 of graph MY2H / } m_3) = 22.5 \text{ (kg)}$$

$$\text{Load factor } \alpha_1 = m_3 / m_3 \text{ max} = 7.025 / 22.5 = 0.31$$

M₂: Moment

$$M_2 \text{ max (from 2 of graph MY2H / } M_2) = 19.5 \text{ (N}\cdot\text{m)}$$

$$M_2 = m_3 \times g \times Z = 7.025 \times 9.8 \times 37.8 \times 10^{-3} = 2.60 \text{ (N}\cdot\text{m)}$$

$$\text{Load factor } \alpha_2 = M_2 / M_2 \text{ max} = 2.60 / 19.5 = 0.13$$

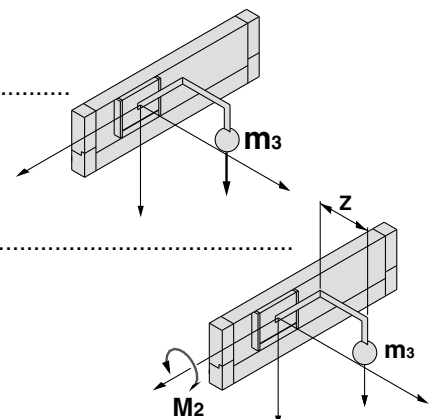

- LJ1
- LG1
- LTF
- LC1
- LC7
- LC8
- LXF
- LXP
- LXS
- LC6
- LZ
- LC3F2
- X
- D-
- E-MY

Model Selection 4

The following are steps for selecting the E-MY2 series best suited for your application.

Calculation of Guide Load Factor

M₃: Moment

$$M_3 \text{ max (from 3 of graph MY2H / } M_3) = 19.5 \text{ (N}\cdot\text{m)} \dots\dots\dots$$

$$M_3 = m_3 \times g \times X = 7.025 \times 9.8 \times 139.4 \times 10^{-3} = 9.59 \text{ (N}\cdot\text{m)}$$

$$\text{Load factor } \alpha_3 = M_3 / M_3 \text{ max} = 9.59 / 19.5 = \mathbf{0.49}$$

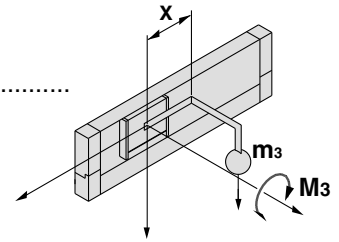

5 Calculation of Load Factor for Dynamic Moment

Load F_E at acceleration and deceleration

$$F_E = m \times a = 7.025 \times 4.9 = 34.42 \text{ (N)}$$

M_{1E}: Moment

$$M_{1E} \text{ max (from 4 of graph MY2H / } M_1) = 21.0 \text{ (N}\cdot\text{m)} \dots\dots\dots$$

$$M_{1E} = \frac{1}{3} \times F_E \times Z = \frac{1}{3} \times 34.42 \times 37.8 \times 10^{-3} = 0.43 \text{ (N}\cdot\text{m)}$$

$$\text{Load factor } \alpha_4 = M_{1E} / M_{1E} \text{ max} = 0.43 / 21.0 = \mathbf{0.02}$$

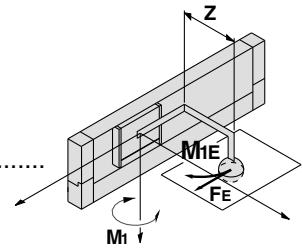

M_{3E}: Moment

$$M_{3E} \text{ max (from 5 of graph MY2H / } M_3) = 19.5 \text{ (N}\cdot\text{m)} \dots\dots\dots$$

$$M_{3E} = \frac{1}{3} \times F_E \times Y = \frac{1}{3} \times 34.42 \times 42.5 \times 10^{-3} = 0.49 \text{ (N}\cdot\text{m)}$$

$$\text{Load factor } \alpha_5 = M_{3E} / M_{3E} \text{ max} = 0.49 / 19.5 = \mathbf{0.03}$$

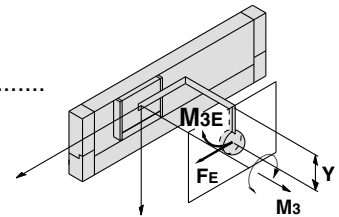

6 Sum and Examination of Guide Load Factors

$$\Sigma\alpha = \alpha_1 + \alpha_2 + \alpha_3 + \alpha_4 + \alpha_5 = \mathbf{0.98} \leq 1$$

The above calculation is within the allowable value and therefore the selected model can be used.

In an actual calculation, when sum of guide load factors $\Sigma\alpha$ in the formula above is more than 1, consider decreasing the speed, increasing the bore size, or changing the product series.

Load Mass

E-MY2H/m₃

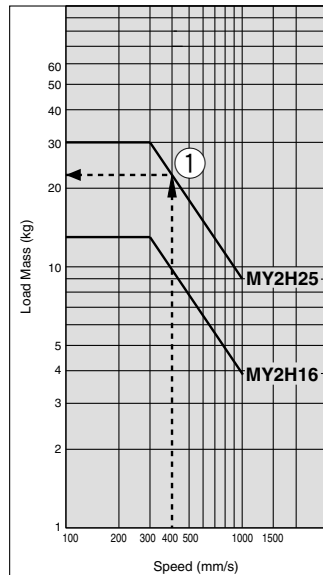

Allowable Moment

E-MY2H/M₁

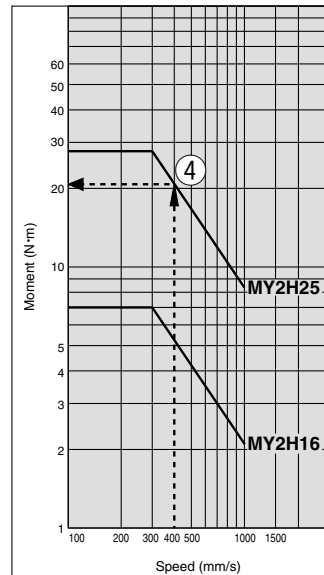

E-MY2H/M₂

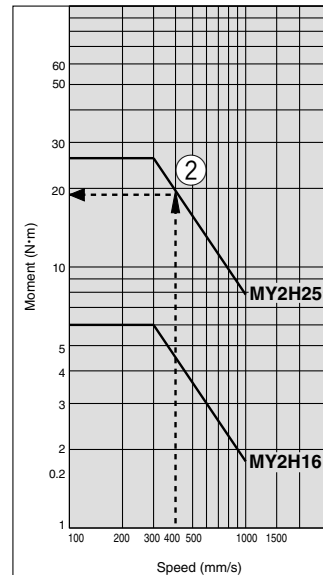

E-MY2H/M₃

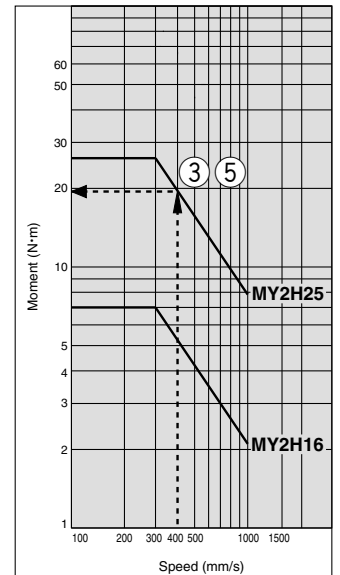

e-Rodless Actuator

Series E-MY2C



Cam Follower Guide Type / Nominal Size: 16, 25

How to Order

Integrated control type E-MY2C 16 [] [] - 100 TA N [] — M9BW [] [] []

Remote control type E-MY2C 16 [] [] - 100 TA N [] M - M9BW [] [] [] [] []

Nominal size

16
25

Speed specifications* [mm/s]

Symbol	Load specifications	Nominal size	16	25
L	Low	10 to 1000		
M	Medium	50 to 1000		
Nil	Standard	100 to 1000		

* Cam follower type is not available for high speed.

Load specifications* Work load [kg]

Symbol	Load specifications	Nominal size	16	25
D	Light load	1.25	2.5	
E	Medium load	2.5	5	
Nil	Standard load	5	10	
Q	Heavy load	10	20	

* For details, refer to "Switch and Speed," "Switch and Acceleration" on the next page.

Stroke

Refer to "Standard Stroke" table.

Motor placement

TA	On the top, Standard
DA	On the bottom, Standard
TB	On the top, Symmetric
DB	On the bottom, Symmetric

Motor

Controller

Made to Order (Refer to page 1127.)

CE compliant

Nil	—
Q	CE marked

* No need to add a suffix for the integrated control type. It is provided with a CE compliant product.
* Noise filter is provided but not attached for the "Q" spec.

Number of auto switches

Nil	2 pcs.
S	1 pc.
n	n

Auto switch

Nil	Without auto switch
-----	---------------------

* Refer to the table below for auto switch model numbers.

Auto switch type

N	NPN
P	PNP

Number of stoppable positioning points

Nil	3-point stoppable type
A	5-point stoppable type

Cable length

M	1 m
L	3 m
Z	5 m

* The remote control type can be selected by adding the above symbols.

Standard Stroke

Nominal size	Standard stroke (mm)
16, 25	100, 200, 300, 400, 500, 600, 700, 800, 900, 1000

* Strokes are manufacturable in increments of 1 mm, up to 100 to 1000 strokes.
* When exceeding a 1000 strokes, refer to "Made to Order" on page 1143.

Applicable Auto Switches / For detailed auto switch specifications, refer to page 352 through to 402.

Type	Special function	Electrical entry	Indicator light	Wiring (Output)	Load voltage			Auto switch model		Lead wire length (m)*				Pre-wired connector	Applicable load	
					DC	AC	Perpendicular	In-line	0.5 (Nil)	1 (M)	3 (L)	5 (Z)				
													5 V			
Solid state switch	—	Grommet	Yes	3-wire (NPN)	24 V	5 V	—	M9NV	M9N	●	●	●	○	○	IC circuit	Relay, PLC
				3-wire (PNP)				M9PV	M9P	●	●	●	○	○		
				2-wire				M9BV	M9B	●	●	●	○	○		
				3-wire (NPN)				M9NWV	M9NW	●	●	●	○	○		
				3-wire (PNP)				M9PWV	M9PW	●	●	●	○	○		
				2-wire				M9BWW	M9BW	●	●	●	○	○		
Reed switch	—	Grommet	Yes	3-wire (NPN equiv.)	24 V	5 V	100 V	A96V	A96	●	—	●	—	—	IC circuit	—
				12 V				A93V	A93	●	—	●	—	—	—	Relay, PLC
				5 V, 12 V				A90V	A90	●	—	●	—	—	—	IC circuit

* Lead wire length symbols: 0.5 m Nil (Example) M9N
1 m M M9NWM
3 m L M9NWL
5 m Z M9NWZ

* Solid state auto switches marked "○" are produced upon receipt of order.
* For details of auto switches with pre-wired connector, refer to pages 389 and 390.
* Auto switch is shipped together, (not assembled).

E-Rodless Actuator Cam Follower Guide Type **Series E-MY2C**



Made to Order
(For details, refer to page 1143.)

Symbol	Specifications
X168	Helical insert thread specifications

Mass

Actuator Unit Unit: kg

Nominal size	Basic mass	Additional mass per 50 mm stroke
16	2.00	0.14
25	3.71	0.21

Remote Controller Unit Unit: kg

Controller body	Cable length		
	1 m	3 m	5 m
0.24	0.09	0.24	0.39

How to calculate/Example: **E-MY2C25-300TANM**

Actuator unit

Basic mass 3.71 kg
 Additional mass 0.21/50 st
 Actuator stroke 300 st
 $3.71 + 0.21 \times 300 \div 50 = 4.97$ kg

Remote controller unit

Controller body 0.24 kg
 Cable length (3 m) 0.24 kg
 $0.24 + 0.24 = 0.48$ kg

* For an integrated control type, add 0.24 kg (controller body) to the basic mass.

Replacement Parts

Drive Unit Replacement Part No.

Model	E-MY2C	
Nominal size		
16	E-MY2BH16*1-	Stroke *2
25	E-MY2BH25*1-	Stroke *2

* Specify the speed / load specifications in *1 parts.
 * Specify the motor position and output style in *2 parts.
 For a remote control type, enter the symbol for cable length.
 Example) E-MY2C16MQ-300TANAL
 Drive unit replacement part no.
 E-MY2BH16MQ-300TANAL

Option / Remote Controller Mounting Bracket

Description	Part no.
L-bracket	MYE-LB
DIN rail bracket	MYE-DB

Basic Specifications

Model		E-MY2C			
Transfer speed set range	Low	10 to 1000 mm/s			
	Medium	50 to 1000 mm/s			
	Standard	100 to 1000 mm/s			
Transfer speed acceleration set range		Heavy load	Standard load	Medium load	Light load
		0.25 to 2.45 m/s ²	0.49 to 4.90 m/s ²	0.98 to 9.80 m/s ²	1.96 to 19.6 m/s ²
Maximum load mass	Note) Nominal size: 16	10 kg	5 kg	2.5 kg	1.25 kg
	Nominal size: 25	20 kg	10 kg	5 kg	2.5 kg
Acceleration and deceleration method		Trapezoidal drive			
Moving direction		Horizontal direction			
Repeated positioning stopping precision	3-point stoppable type	Both ends (Mechanical stoppers), 1 intermediate position			
	5-point stoppable type	Both ends (Mechanical stoppers), 3 intermediate positions			
Repeated positioning stopping precision	Both ends	± 0.01 mm			
	Intermediate stopping position	± 0.1 mm			
Allowable external resistance	Nominal size: 16	10 N			
	Nominal size: 25	20 N			
Intermediate stopping point positioning method		Direct teaching, JOG teaching			
Positioning setting spot		Controller body			
Display		LED for power supply, LED for alarming, LED for positioning completion			
Input signal		Actuation command signal, Emergency stop input signal			
Output signal		Positioning completion signal, Emergency detection signal, Ready signal			

Note) The maximum load mass shows the motor ability. Please consider it together with the guide load factor when selecting a model.

Electrical Specifications

Power supply for driving	Power supply voltage	24 VDC ± 10%
	Current consumption	Rated current 2.5 A (Max. 5 A: 2 s or less) at 24 VDC
Power supply for signals	Power supply voltage	24 VDC ± 10%
	Current consumption	30 mA at 24 VDC and Output load capacity
Input signal capacity		6 mA or less at 24 VDC/1 circuit (Photo coupler input)
Output load capacity		30 VDC or less, 20 mA or less/1 circuit (Open drain output)
Emergency detection items		Emergency stop, Output deviation, Power supply deviation, Driving deviation, Temperature deviation, Stroke deviation, Motor deviation, Controller deviation

Environmental Specifications

Operating temperature range	Integrated control type	5 to 40°C
	Remote control type	5 to 50°C
	Actuator unit	5 to 40°C
Operating humidity range		35 to 85%RH (No condensation)
Storage temperature range		-10 to 60°C (No condensation and freezing)
Storage humidity range		35 to 85%RH (No condensation)
Withstand voltage		Between all of external terminals and the case: 500 VAC for 1 minute
Insulation resistance		Between all of external terminals and the case: 50 MΩ (500 VDC)
Noise resistance		1000 Vp-p Pulse width 1 μs, Rise time 1 ns
CE marked	Integrated control type	Standard
	Remote control type	Available with -Q suffixed products only

Speed / Acceleration

Switch and Speed ^{Note 1)} [mm/s]				Switch and Acceleration ^{Note 2)} [m/s ²]				
Switch no.	Low speed	Medium speed	Standard speed	Switch no.	Heavy load	Standard load	Medium load	Light load
1	10	50	100	1	0.25	0.49	0.98	1.96
2	20	75	200	2	0.49	0.74	1.47	2.94
3	30	100	300	3	0.74	0.98	1.96	3.92
4	40	125	400	4	0.98	1.23	2.45	4.90
5	50	150	500	5	1.23	1.47	2.94	5.88
6	75	200	600	6	1.47	1.96	3.92	7.84
7	100	250	700	7	1.72	2.45	4.90	9.80
8	300	300	800	8	1.96	2.94	5.88	11.76
9	500	500	900	9	2.21	3.92	7.84	15.68
10	1000	1000	1000	10	2.45	4.90	9.80	19.60

Note 1) The factory default setting for the switch is No.1.

Note 2) The factory default setting for the switch is No.1.

Note 3) Cam follower type is not available for high speed.

LJ1

LG1

LTF

LC1

LC7

LC8

LXF

LXP

LXS

LC6

LZ

LC3F2

X

D-

E-MY

Series E-MY2C

Dimensions: Integrated Control Type

E-MY2C **Nominal size** – **Stroke**

Nominal size: 16

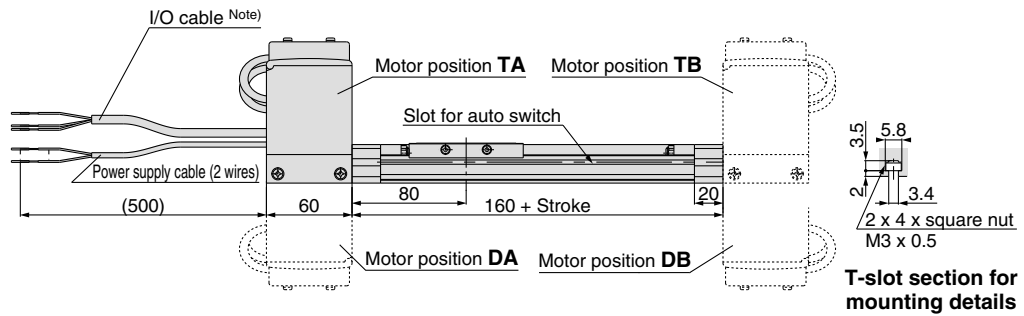
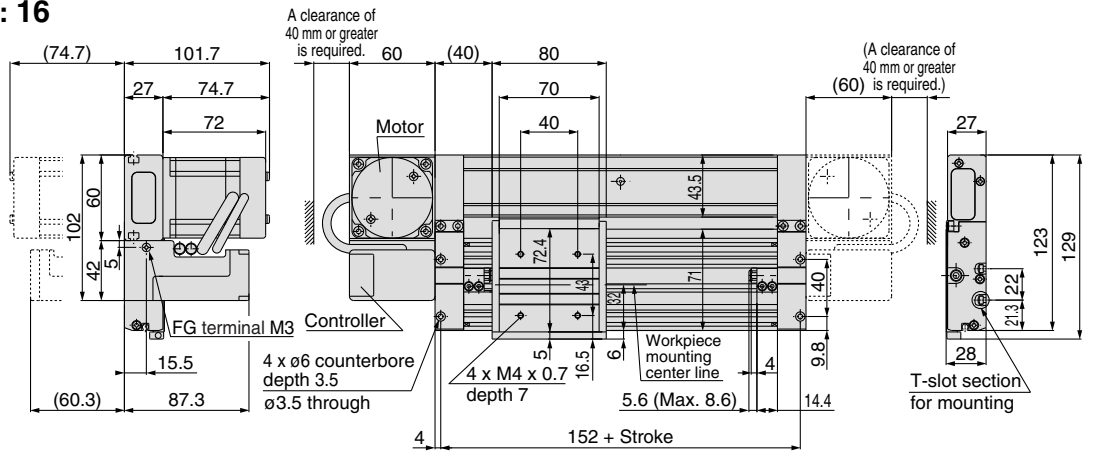

Nominal size: 25

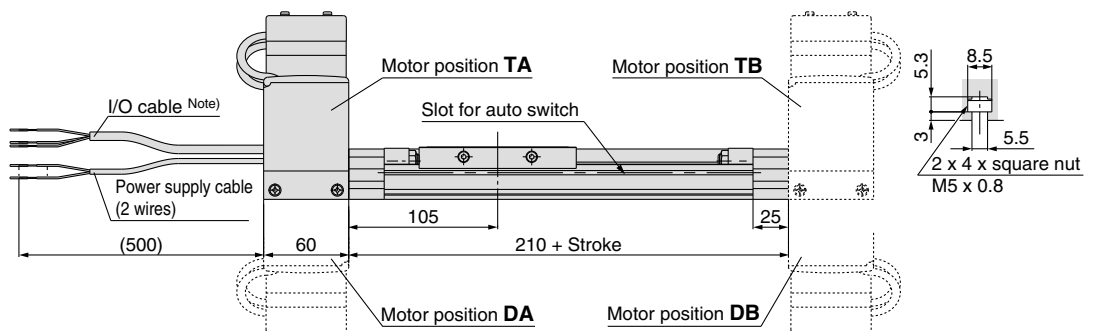
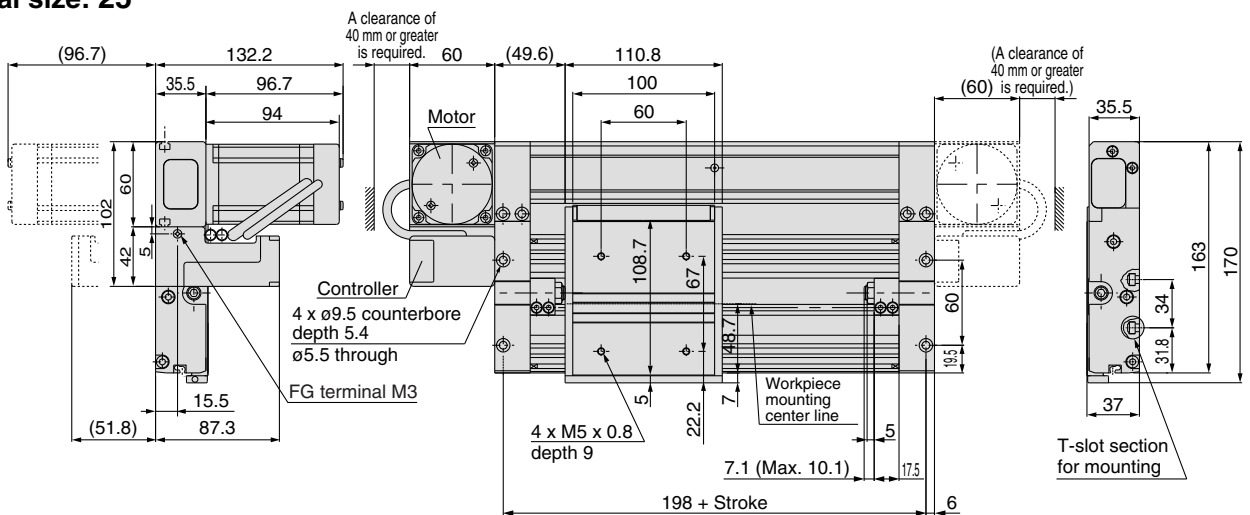

Note) For the 3-point stoppable type, the I/O cable is a 9-core type and for the 5-point stoppable type, a 11-core type is used.

Dimensions: Remote Control Type (Actuator unit)

E-MY2C **Nominal size** – **Stroke** **M**
 L
 Z

* Refer to page 1130 for dimensions of remote controller.

Nominal size: 16

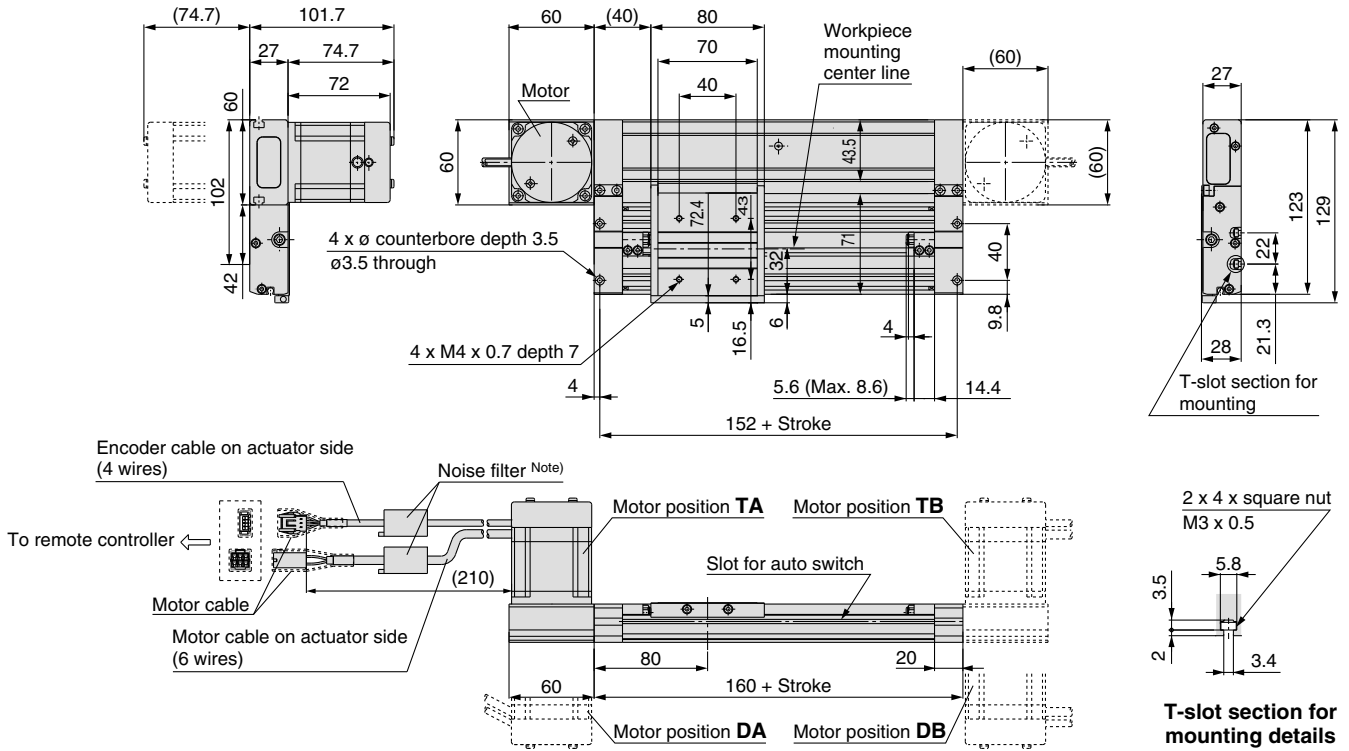

Nominal size: 25

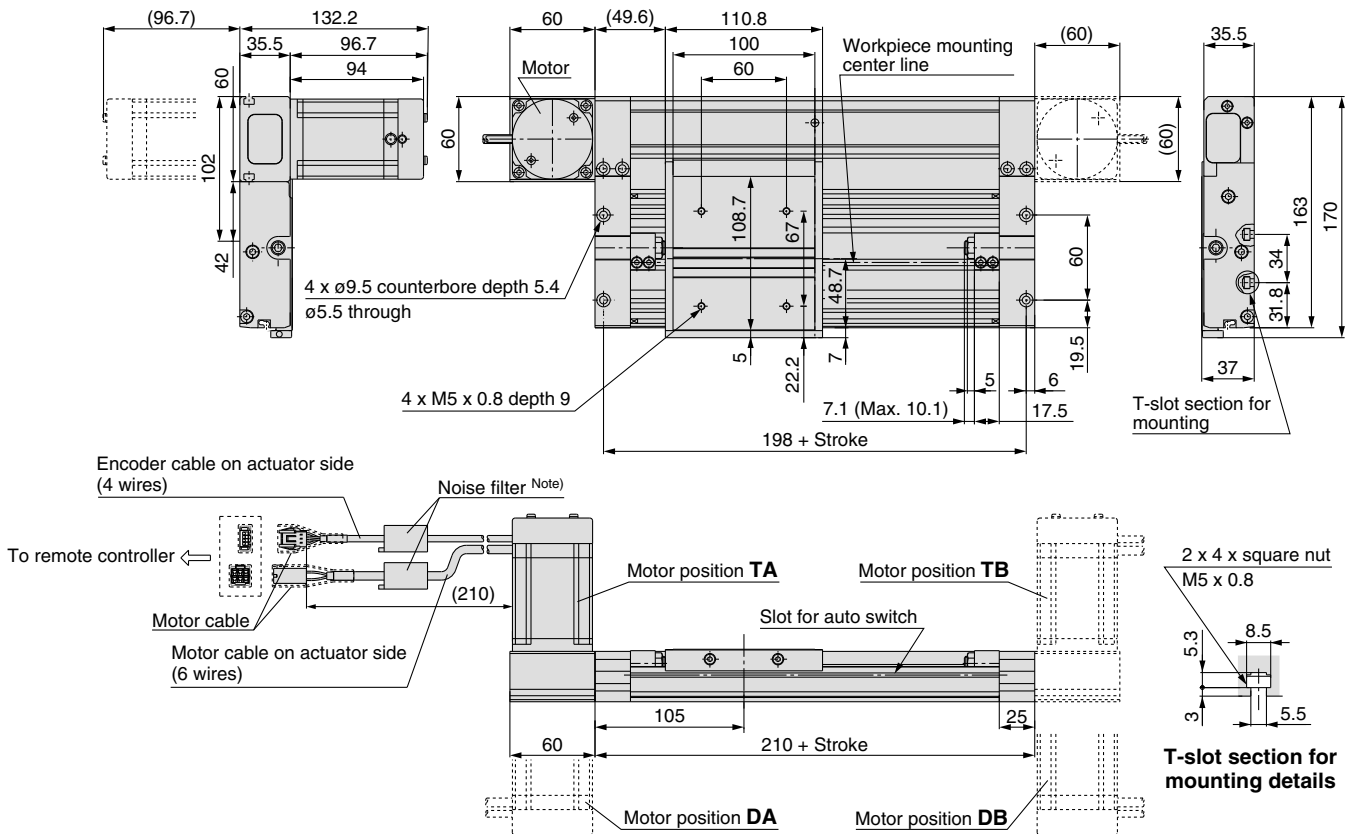

Note) When the CE compliant model is selected, a noise filter is provided but not attached.

The cable for the CE compliant models uses the dedicated shielding. Even if a noise filter is attached to a non CE marked products, the products cannot be changed to a CE compliant product.

- LJ1
- LG1
- LTF
- LC1
- LC7
- LC8
- LXF
- LXP
- LXS
- LC6
- LZ
- LC3F2
- X
- D-
- E-MY

Series E-MY2C

Dimensions: Remote Control Type (Remote controller unit)

Controller

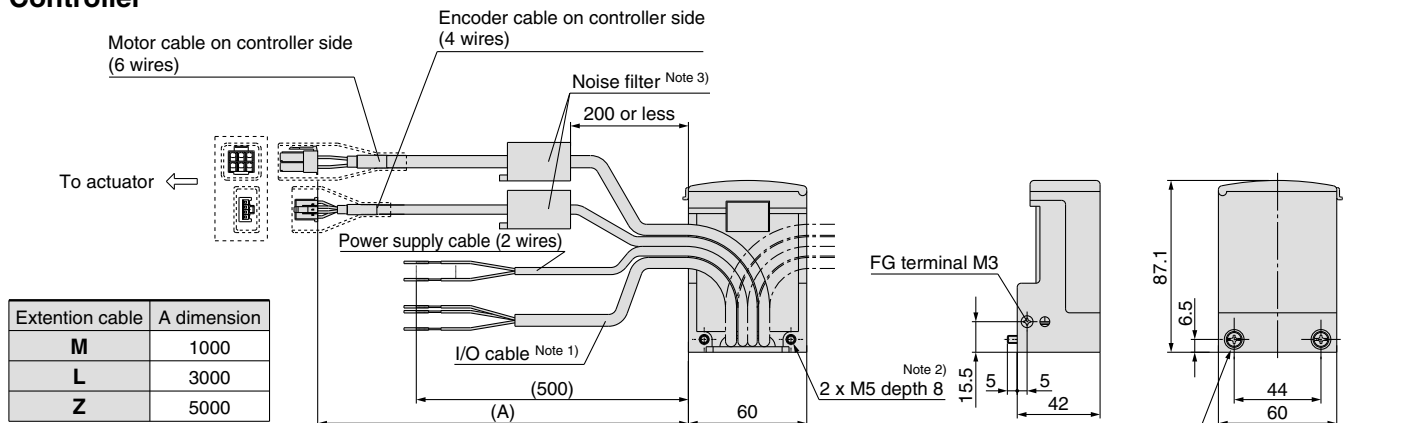

Note 1) For the 3-point stoppable type, the I/O cable is a 9-core type and for the 5-point stoppable type, a 11-core type is used.

Note 2) When mounting the remote controller, use the included M4 screw or use the M5 tap located on one side of the controller.

Note 3) When the CE compliant model is selected, a noise filter is included but not attached. The cable for the CE compliant models uses the dedicated shielding. Even if a noise filter is attached to a non CE marked product, the products cannot be changed to a CE compliant product.

L-bracket / MYE-LB (Option)

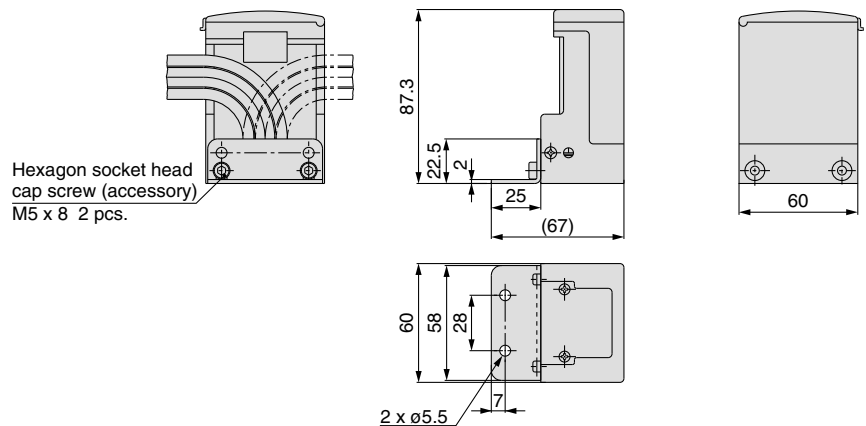

DIN rail bracket / MYE-DB (Option)

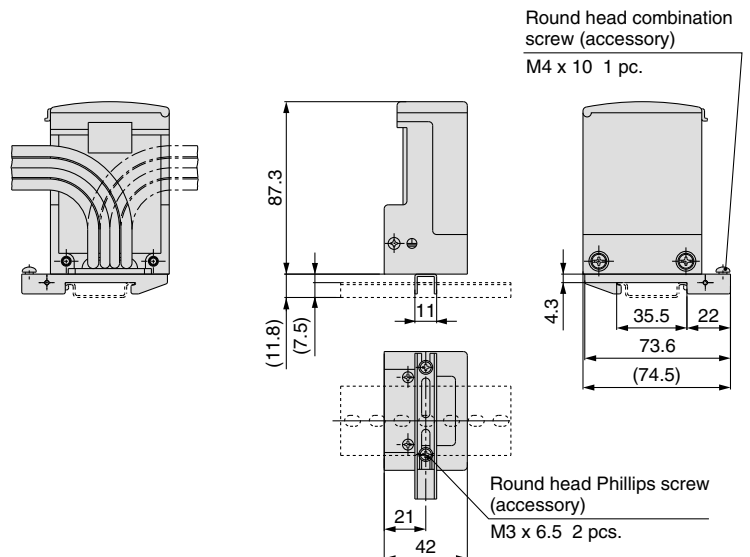

e-Rodless Actuator

Series E-MY2H/HT

Linear Guide Type / Nominal Size: 16, 25

How to Order

Integrated control type E-MY2 H 16 [] [] - 100 TA N [] — M9BW [] — []

Remote control type E-MY2 H 16 [] [] - 100 TA N [] M - M9BW [] - [] - []

Suffix for guide ● **Nominal size** ●

H	Linear guide single axis	16
HT	Linear guide double axis	25

Stroke ● Refer to "Standard Stroke" table.

Speed specifications ● [mm/s]

L	Low	10 to 1000
M	Medium	50 to 1000
Nil	Standard	100 to 1000
H	High	200 to 2000

Motor placement ●

TA	On the top, Standard
DA	On the bottom, Standard
TB	On the top, Symmetric
DB	On the bottom, Symmetric

Output type ●

N	NPN
P	PNP

CE compliant

Nil	—
Q	CE marked

* No need to add a suffix for the integrated control type. It is provided with a CE compliant product.
* Noise filter is provided but not attached for the "Q" spec.

Number of auto switches

Nil	2 pcs.
S	1 pc.
n	n

Auto switch

Nil	Without auto switch (built-in magnet)
-----	---------------------------------------

* Refer to the table below for auto switch model numbers.

Number of stoppable positioning points

Nil	3-point stoppable type
A	5-point stoppable type

Cable length

M	1 m
L	3 m
Z	5 m

* The remote control type can be selected by adding the above symbols.

Load specifications ● Work load [kg]

Symbol	Load specifications	Nominal size	16	25
D	Light load		1.25	2.5
E	Medium load		2.5	5
Nil	Standard load		5	10
Q	Heavy load		10	20

* For details, refer to "Switch and Speed," "Switch and Acceleration" on the next page.

* Arrow mark shows handling side on controller.

Standard Stroke

Nominal size	Standard stroke (mm)	Made to Order
		Long stroke (-XB11)
16, 25	50, 100, 150, 200, 250, 300, 350, 400, 450, 500, 550, 600	Stroke range (mm)
		601 to 1000

- * Strokes are manufacturable in increments of 1 mm, up to 1000 strokes.
- However, when a stroke out of the standard 51 to 599 is required, add "-XB10" at the end of the model no.
- When stroke exceeds 600 mm, add "-XB11" at the end of model no. Refer to "Made to Order" on page 1143.
- * When exceeding a 1000 strokes, refer to "Made to Order" on page 1143.

Applicable Auto Switches / For detailed auto switch specifications, refer to page 352 through to 402.

Type	Special function	Electrical entry	Indicator light	Wiring (Output)	Load voltage		Auto switch model		Lead wire length (m) *				Pre-wired connector	Applicable load			
					DC	AC	Electrical entry direction		0.5 (Nil)	1 (M)	3 (L)	5 (Z)		IC circuit	Relay, PLC		
							Perpendicular	In-line									
Solid state switch	—	Grommet	Yes	3-wire (NPN)	24 V	5 V	—	M9NV	M9N	●	●	●	○	○	IC circuit	Relay, PLC	
				3-wire (PNP)				M9PV	M9P	●	●	●	○				
				2-wire				M9BV	M9B	●	●	●	○				○
				3-wire (NPN)				M9NWV	M9NW	●	●	●	○				○
				3-wire (PNP)				M9PWV	M9PW	●	●	●	○				○
				2-wire				M9BWW	M9BW	●	●	●	○				○
Reed switch	—	Grommet	Yes	3-wire (NPN equiv.)	24 V	5 V	100 V	A96V	A96	●	—	●	—	—	IC circuit	—	
				12 V				A93V	A93	●	—	●	—				
				5 V, 12 V				A90V	A90	●	—	●	—				
			None	2-wire													

- * Lead wire length symbols: 0.5 m Nil (Example) M9N
- 1 m M M9NWM
- 3 m L M9NWL
- 5 m Z M9NWZ

- * Solid state auto switches marked "○" are produced upon receipt of order.
- * For details of auto switches with pre-wired connector, refer to pages 389 and 390.
- * Auto switch is shipped together, (not assembled).

e-Rodless Actuator Linear Guide Type **Series E-MY2H/HT**



Made to Order
(For details, refer to page 1143.)

Symbol	Specifications
XB10	Intermediate stroke
XB11	Long stroke
X168	Helical insert thread specifications

Mass

Actuator Unit Unit: kg

Model	Nominal size	Basic mass	Additional mass per 50 mm stroke
E-MY2H	16	1.87	0.14
	25	3.37	0.23
E-MY2HT	16	2.30	0.21
	25	4.59	0.38

Remote Controller Unit Unit: kg

Controller body	Cable length		
	1 m	3 m	5 m
0.24	0.09	0.24	0.39

How to calculate/Example: **E-MY2H25-300TANM**

Actuator unit

Basic mass 3.37 kg
 Additional mass 0.23/50 st
 Actuator stroke 300 st
 $3.37 + 0.23 \times 300 \div 50 = 4.75$ kg

Remote controller unit

Controller body 0.24 kg
 Cable length (3 m) 0.24 kg
 $0.24 + 0.24 = 0.48$ kg

* For an integrated control type, add 0.24 kg (controller body) to the basic mass.

Replacement Parts

Drive Unit Replacement Part No.

Model	E-MY2H/HT
Nominal size	
16	E-MY2BH16*1- <input type="text"/> Stroke *2
25	E-MY2BH25*1- <input type="text"/> Stroke *2

* Specify the speed / load specifications in *1 parts.
 * Specify the motor position and output style in *2 parts.
 For a remote control type, enter the symbol for cable length.
 Example) E-MY2H16MQ-300TANAL
 Drive unit replacement part no.
 E-MY2BH16MQ-300TANAL

Option / Remote Controller Mounting Bracket

Description	Part no.
L-bracket	MYE-LB
DIN rail bracket	MYE-DB

Basic Specifications

Model		E-MY2H/HT			
Transfer speed set range	Low	10 to 1000 mm/s			
	Medium	50 to 1000 mm/s			
	Standard	100 to 1000 mm/s			
	High	200 to 2000 mm/s			
Transfer speed acceleration set range		Heavy load	Standard load	Medium load	Light load
		0.25 to 2.45 m/s ²	0.49 to 4.90 m/s ²	0.98 to 9.80 m/s ²	1.96 to 19.6 m/s ²
Maximum load mass	Note) Nominal size: 16	10 kg	5 kg	2.5 kg	1.25 kg
	Nominal size: 25	20 kg	10 kg	5 kg	2.5 kg
Acceleration and deceleration method		Trapezoidal drive			
Moving direction		Horizontal direction			
Repeated positioning stopping precision	3-point stoppable type	Both ends (Mechanical stoppers), 1 intermediate position			
	5-point stoppable type	Both ends (Mechanical stoppers), 3 intermediate positions			
Repeated positioning stopping precision	Both ends	± 0.01 mm			
	Intermediate stopping position	± 0.1 mm			
Allowable external resistance	Nominal size: 16	10 N			
	Nominal size: 25	20 N			
Intermediate stopping point positioning method		Direct teaching, JOG teaching			
Positioning setting spot		Controller body			
Display		LED for power supply, LED for alarming, LED for positioning completion			
Input signal		Actuation command signal, Emergency stop input signal			
Output signal		Positioning completion signal, Emergency detection signal, Ready signal			

Note) The maximum load mass shows the motor ability. Please consider it together with the guide load factor when selecting a model.

Electrical Specifications

Power supply for driving	Power supply voltage	24 VDC ± 10%
	Current consumption	Rated current 2.5 A (Max. 5 A: 2 s or less) at 24 VDC
Power supply for signals	Power supply voltage	24 VDC ± 10%
	Current consumption	30 mA at 24 VDC and Output load capacity
Input signal capacity		6 mA or less at 24 VDC/1 circuit (Photo coupler input)
Output load capacity		30 VDC or less, 20 mA or less/1 circuit (Open drain output)
Emergency detection items		Emergency stop, Output deviation, Power supply deviation, Driving deviation, Temperature deviation, Stroke deviation, Motor deviation, Controller deviation

Environmental Specifications

Operating temperature range	Integrated control type		5 to 40°C
	Remote control type	Actuator unit	5 to 50°C
		Remote controller unit	5 to 40°C
Operating humidity range		35 to 85%RH (No condensation)	
Storage temperature range		-10 to 60°C (No condensation and freezing)	
Storage humidity range		35 to 85%RH (No condensation)	
Withstand voltage		Between all of external terminals and the case: 500 VAC for 1 minute	
Insulation resistance		Between all of external terminals and the case: 50 MΩ (500 VDC)	
Noise resistance		1000 Vp-p Pulse width 1 μs, Rise time 1 ns	
CE marked	Integrated control type		Standard
	Remote control type		Available with -Q suffixed products only (Option)

Speed / Acceleration

Switch and Speed ^{Note 1)} [mm/s]					Switch and Acceleration ^{Note 2)} [m/s ²]				
Switch no.	Low speed	Medium speed	Standard speed	High speed	Switch no.	Heavy load	Standard load	Medium load	Light load
1	10	50	100	200	1	0.25	0.49	0.98	1.96
2	20	75	200	400	2	0.49	0.74	1.47	2.94
3	30	100	300	600	3	0.74	0.98	1.96	3.92
4	40	125	400	800	4	0.98	1.23	2.45	4.90
5	50	150	500	1000	5	1.23	1.47	2.94	5.88
6	75	200	600	1200	6	1.47	1.96	3.92	7.84
7	100	250	700	1400	7	1.72	2.45	4.90	9.80
8	300	300	800	1600	8	1.96	2.94	5.88	11.76
9	500	500	900	1800	9	2.21	3.92	7.84	15.68
10	1000	1000	1000	2000	10	2.45	4.90	9.80	19.60

Note 1) The factory default setting for the switch is No.1.
 Note 2) The factory default setting for the switch is No.1.

Series E-MY2H/HT

Dimensions: Integrated Control Type

E-MY2H **Nominal size** – **Stroke**

Nominal size: 16

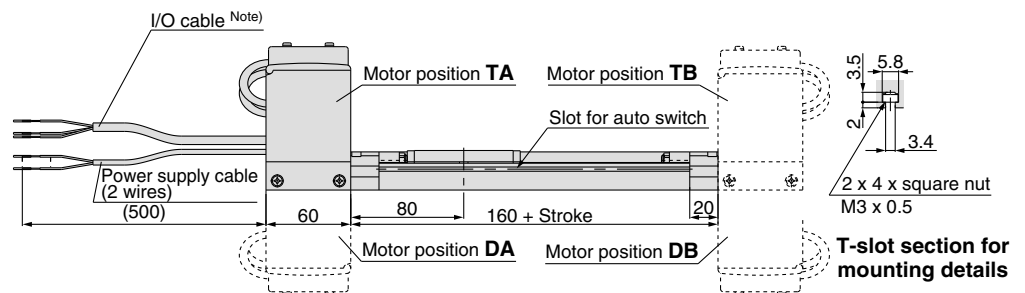
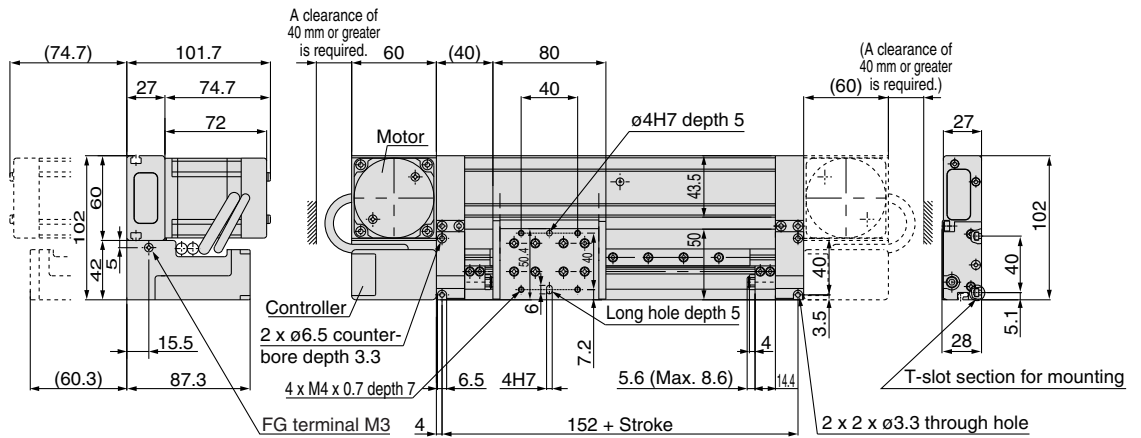

Nominal size: 25

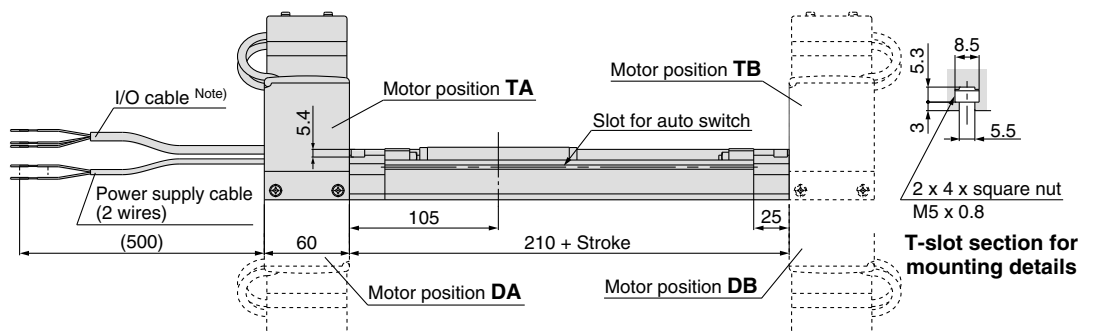
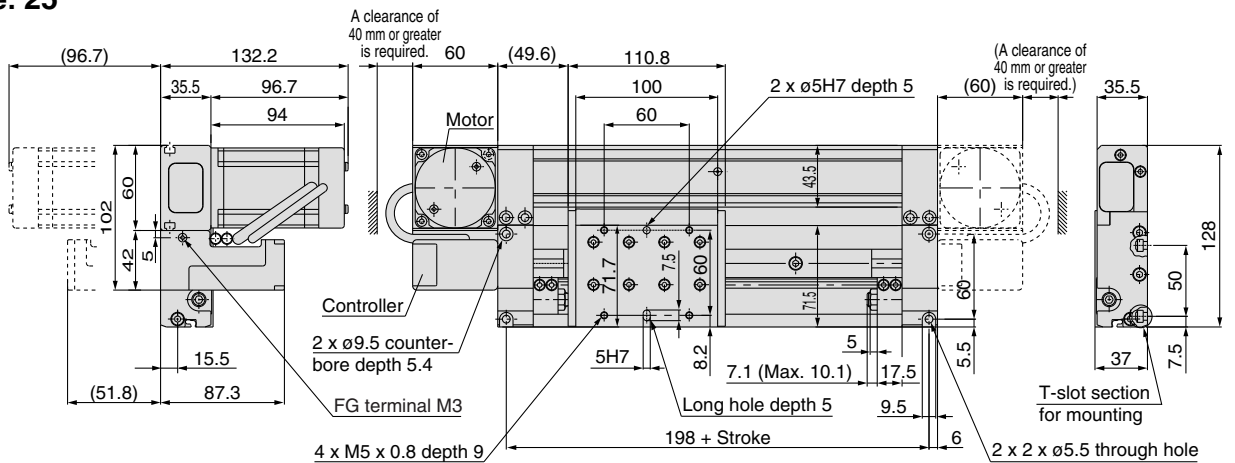

Note) For the 3-point stoppable type, the I/O cable is a 9-core type and for the 5-point stoppable type, a 11-core type is used.

Dimensions: Remote Control Type (Actuator unit)

E-MY2HT Nominal size Stroke **M**
 L **Z**

* Refer to page 1138 for dimensions of remote controller.

Nominal size: 16

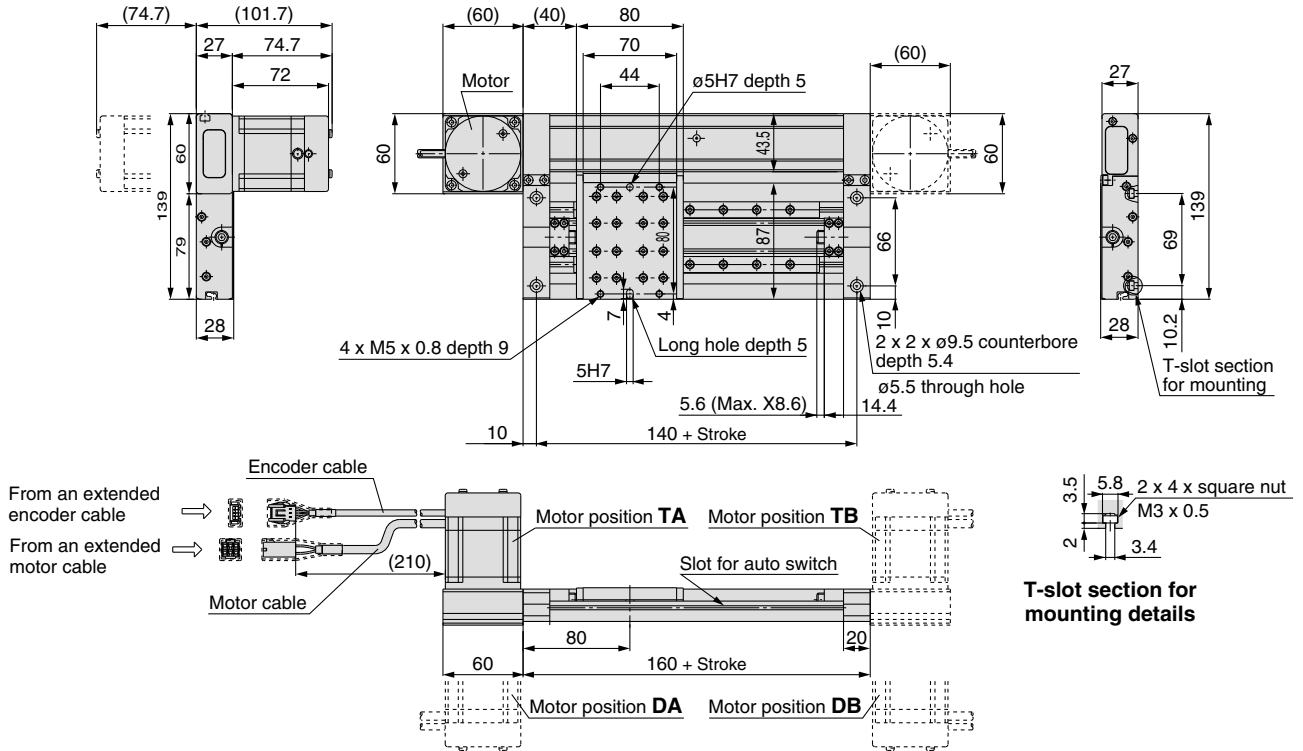

Nominal size: 25

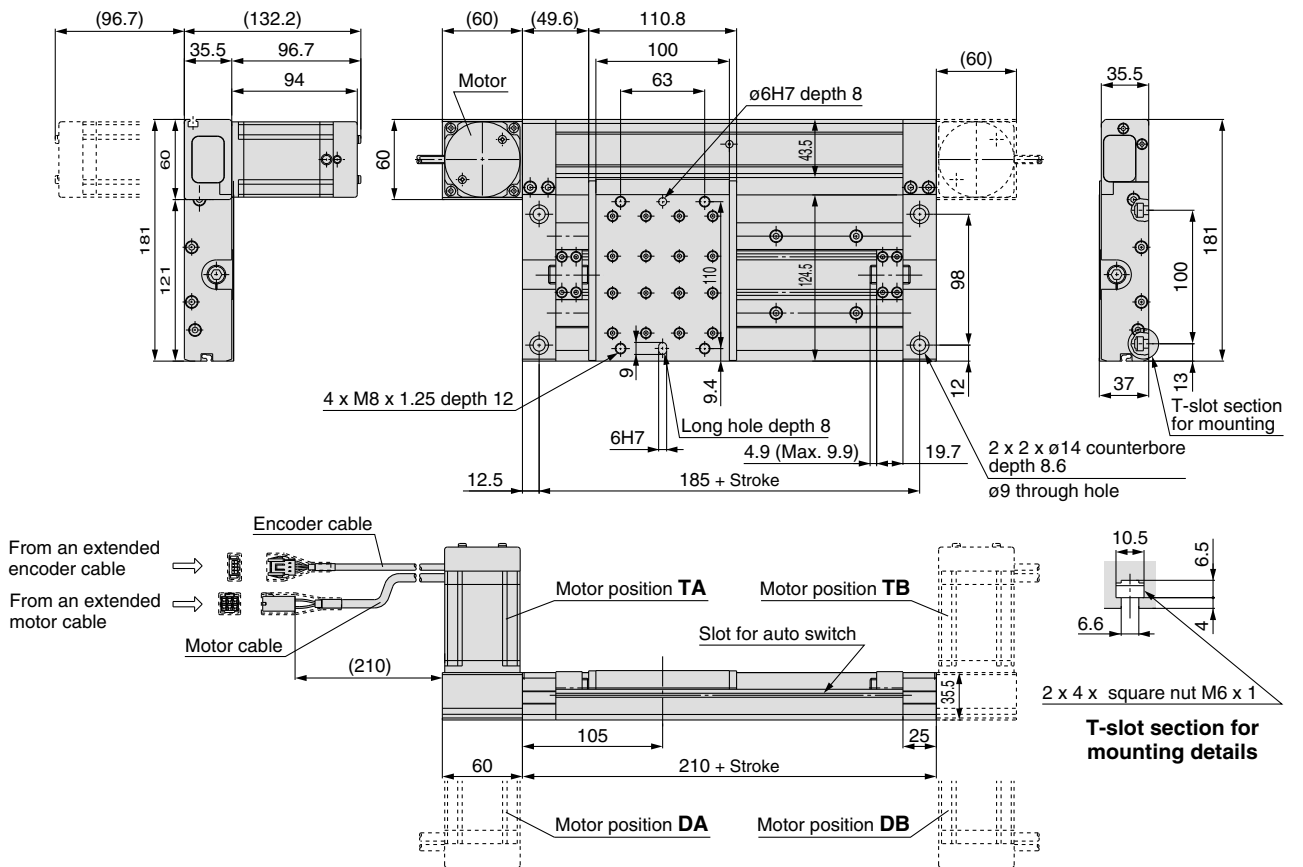

Note) When the CE compliant model is selected, a noise filter is provided but not attached.

The cable for the CE compliant models uses the dedicated shielding. Even if a noise filter is attached to a non CE marked products, the products cannot be changed to a CE compliant product.

- LJ1
- LG1
- LTF
- LC1
- LC7
- LC8
- LXF
- LXP
- LXS
- LC6
- LZ
- LC3F2
- X
- D
- E-MY

Series E-MY2H/HT

Dimensions: Remote Control Type (Remote controller unit)

Controller

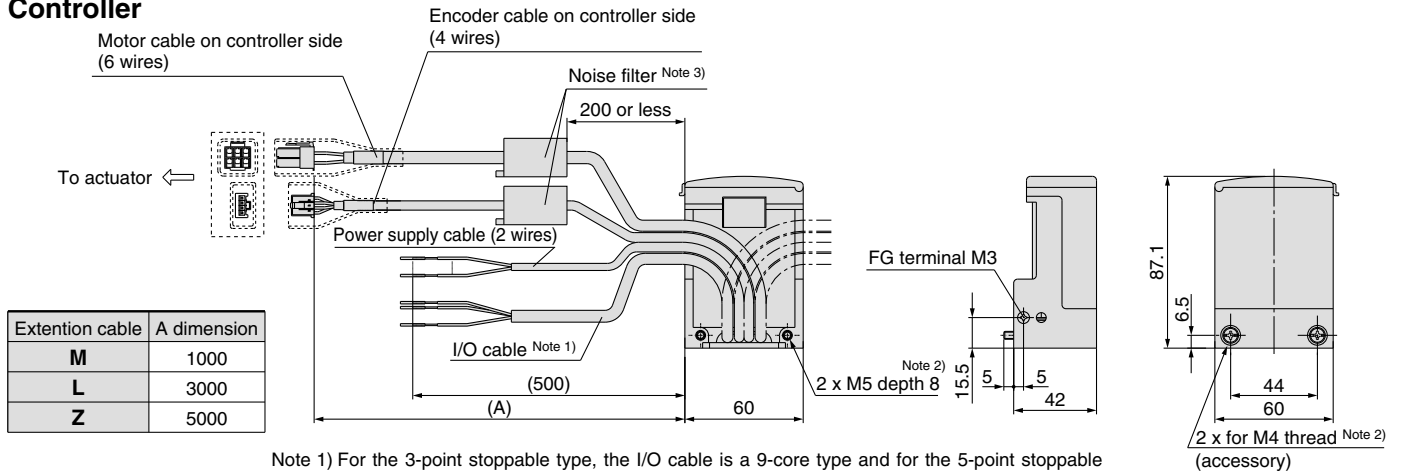

- Note 1) For the 3-point stoppable type, the I/O cable is a 9-core type and for the 5-point stoppable type, a 11-core type is used.
- Note 2) When mounting the remote controller, use the included M4 screw or use the M5 tap located on one side of the controller.
- Note 3) When the CE compliant model is selected, a noise filter is provided but not attached. The cable for the CE compliant models uses the dedicated shielding. Even if a noise filter is attached to a non CE marked product, the product cannot be changed to a CE compliant product.

L-bracket / MYE-LB (Option)

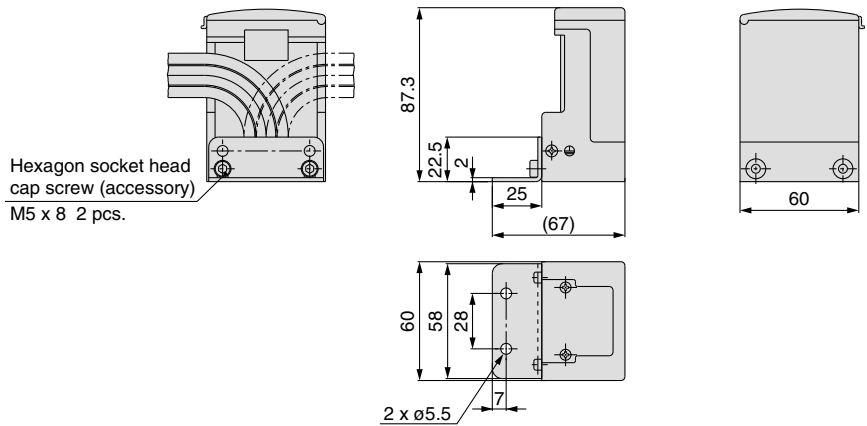

DIN rail bracket / MYE-DB (Option)

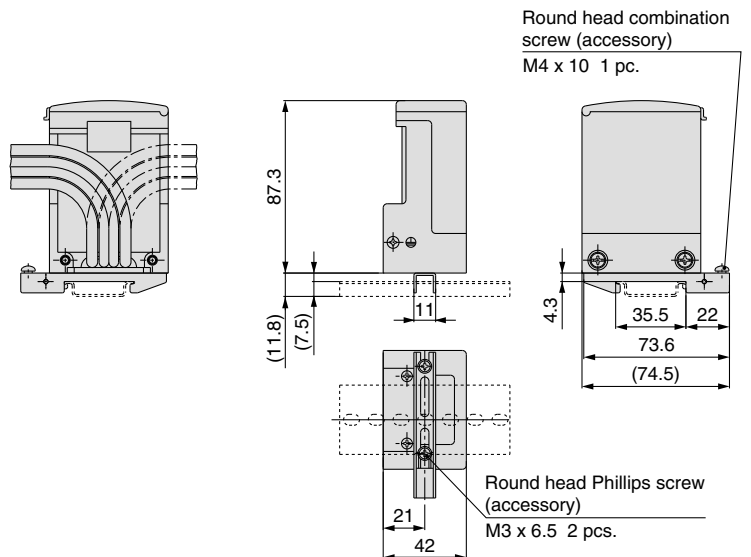

Note) The operating range is a guide including hysteresis, but is not guaranteed. There may be large variations (as much as $\pm 30\%$) depending on the ambient environment.

Auto Switch Proper Mounting Position at Stroke End Detection

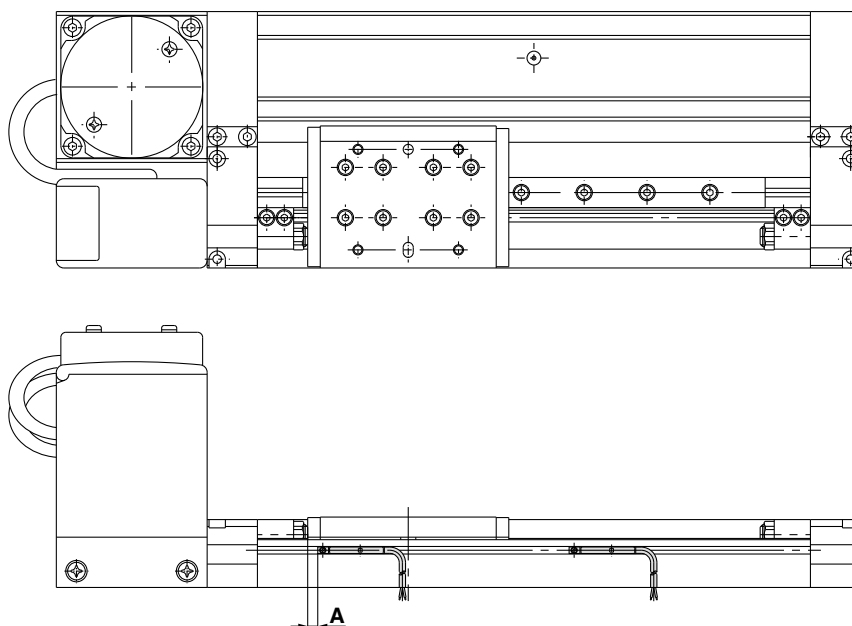

D-A9, D-A9□V

Model	Nominal size	A	Operating range
E-MY2C	16	4	8.5
E-MY2H		6	
E-MY2HT		30	
E-MY2C E-MY2H E-MY2HT	25	4.4	

D-M9, D-M9□V

D-M9□W, D-M9□WV

Model	Nominal size	A	Operating range
E-MY2C	16	8	6
E-MY2H		10	
E-MY2HT		34	
E-MY2C E-MY2H E-MY2HT	25	8.4	9

Auto Switch Mounting

When mounting the auto switches, they should be inserted into the actuator's auto switches mounting groove from the direction shown in the drawing on the right. Once in the mounting position, use a flat head watchmaker's screwdriver to tighten the included auto switch mounting screw.

Note) When tightening the auto switch mounting screw, use a watchmaker's screwdriver with a handle diameter of about 5 to 6 mm. The tightening torque should be 0.1 to 0.2 N·m.

Auto Switch Mounting Screw Tightening Torque

Auto switch model	Tightening torque (N·m)
D-A9□(V)	0.10 to 0.20
D-M9□(V) D-M9□W(V)	0.10 to 0.15

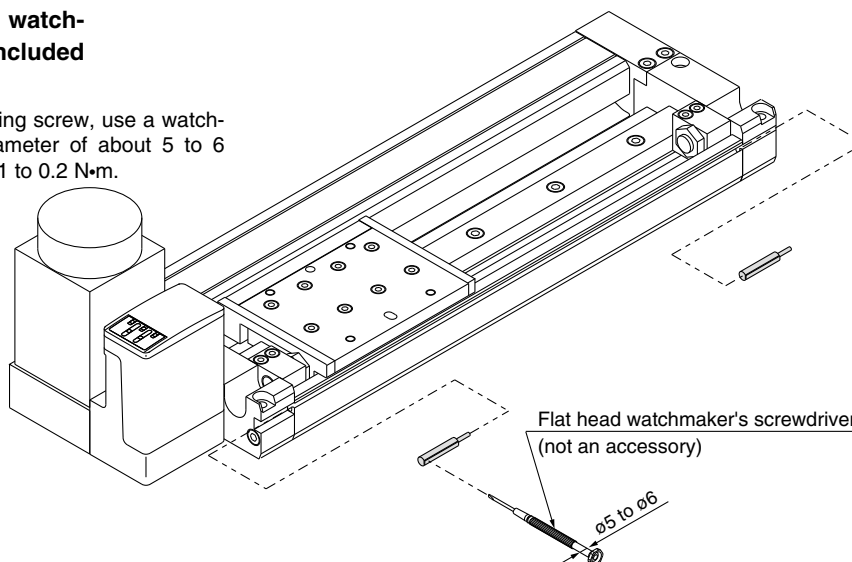

LJ1

LG1

LTF

LC1

LC7

LC8

LXF

LXP

LXS

LC6□

LZ□

LC3F2

X□

D-□

E-MY

Series E-MY2

Names and Functions of Individual Part

Integrated control type

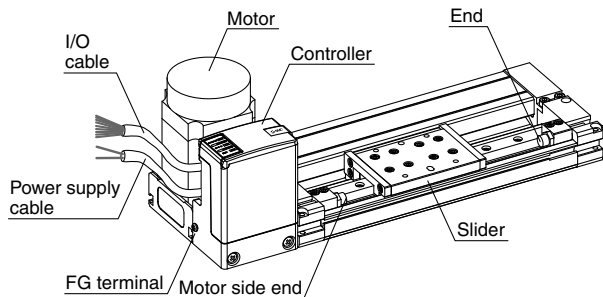

Remote control type

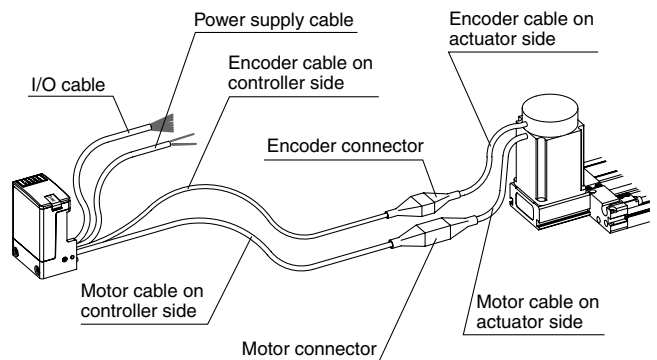

Description	Contents/Functions
Slider	Moving part within the actuator
Motor	Motor activating the actuator
Power supply cable	Power supply cable for providing power to the actuator
I/O cable	I/O cable for transmitting a positioning completion signal and driving instructions
Controller unit	The unit to control and set the actuator, and indicate its status
FG terminal	The terminal to connect the FG cable
Encoder cable on actuator side	Encoder cable for connecting the actuator with the controller
Motor cable on actuator side	Motor cable for connecting the actuator with the controller
Encoder cable on controller side	Encoder cable for separating the controller
Motor cable on controller side	Motor cable for separating the controller

Controller detail

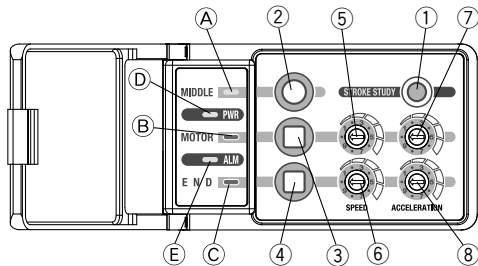

Switch

Description	Contents/Functions
1	Stroke learning switch
2 to 4	Switch to move the actuator to intermediate position and set the intermediate position
5	Rotary switch to set moving speed to the motor side end
6	Rotary switch to set moving speed to the other end
7	Rotary switch to set moving acceleration to the motor side end
8	Rotary switch to set moving acceleration to the other end

Indicator Light and the Display for the Basic Functions

Symbol	Description	Power supply ON	Actuation instruction					When decelerated and completely stopped *1	When the alarm is activated.
			Motor side	End side	Intermediate *1 1	Intermediate *1 2	Intermediate *1 3		
A	MIDDLE Indicator light (Green)	—	—	—	○	○	○	—	*2
B	MOTOR Indicator light (Green)	—	○	—	—	○	—	○	
C	END Indicator light (Green)	—	—	○	—	—	○	○	
D	PWR Indicator light (Green)	○	○	○	○	○	○	○	○
E	ALM Indicator light (Red)	—	—	—	—	—	—	—	○

○ indicates on status, and — indicates off status.

*1) Displays for the 5-point stoppable type only.

*2) When the alarm is activated, see page 1142 for the ALM display.

Internal Circuits and Wiring Examples

3-point Stoppable Type

Power Supply Cable 2-core AWG20 (20 wires/0.16 mm²)

Symbol	Color	Signal name	Contents
DC1 (+)	Brown	Vcc	Power supply cables for driving the actuator
DC1 (-)	Blue	GND	

I/O Cable 9-core AWG28 (7 wires/0.127 mm²)

Symbol	Color	Signal name	Contents
DC2 (+)	Brown	Vcc	Power supply cables for signal
DC2 (-)	Blue	GND	
OUT1	Pink	READY output	Signal indicating the controller is operable
OUT2	Orange	Positioning completion output 1	Signal indicating that positioning is completed
OUT3	Yellow	Positioning completion output 2	
OUT4	Green	Alarm output	Signal indicating an alarm has been generated
IN1	Purple	Actuation instruction input 1	Instruction signal to actuator
IN2	Gray	Actuation instruction input 2	
IN3	White	Emergency stop	Signal providing emergency stop instruction (The emergency stop is activated when contact is opened)

This product can be used without connecting I/O cables, however please use caution and install a power supply switch for the actuator. In case of an emergency, please turn it off.

I/O Cable Signals

Input signal

Command	Symbol	
	IN1	IN2
Motor side actuation instruction	○	—
End side actuation instruction	—	○
Intermediate actuation instruction	○	○

Output signal

Actuator status	Symbol		
	OUT1	OUT2	OUT3
Completion of motor side end positioning	○	○	—
Completion of end positioning	○	—	○
Completion of intermediate positioning	○	○	○

○ indicates on status, and — indicates off status.

NPN input/output circuit

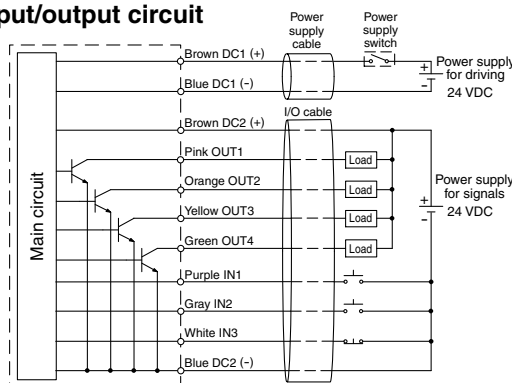

PNP input/output circuit

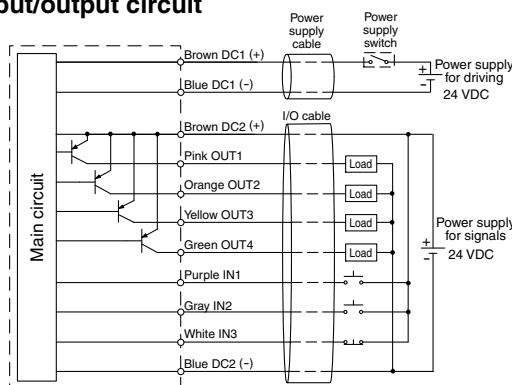

5-point Stoppable Type

Power Supply Cable 2-core AWG20 (20 wires/0.16 mm²)

Symbol	Color	Signal name	Contents
DC1 (+)	Brown	Vcc	Power supply cables for driving the actuator
DC1 (-)	Blue	GND	

I/O Cable 11-core AWG28 (7 wires/0.127 mm²)

Symbol	Color	Signal name	Contents
DC2 (+)	Brown	Vcc	Power supply cables for signal
DC2 (-)	Blue	GND	
OUT1	Pink	READY output	Signal indicating the controller is operable
OUT2	Orange	Positioning completion output 1	Signal indicating that positioning is completed
OUT3	Yellow	Positioning completion output 2	
OUT4	Red	Positioning completion output 3	
OUT5	Green	Alarm output	Signal indicating an alarm has been generated
IN1	Purple	Actuation instruction input 1	Instruction signal to actuator
IN2	Gray	Actuation instruction input 2	
IN3	Black	Actuation instruction input 3	
IN3	White	Emergency stop	Signal providing emergency stop instruction (The emergency stop is activated when contact is opened)

This product can be used without connecting I/O cables, however please use caution and install a power supply switch for the actuator. In case of an emergency, please turn it off.

I/O Cable Signals

Input signal

Command	Symbol		
	IN1	IN2	IN3
Motor side actuation instruction	○	—	—
End side actuation instruction	—	○	—
Intermediate actuation instruction 1	—	—	○
Intermediate actuation instruction 2	○	—	○
Intermediate actuation instruction 3	—	○	○
External input stop instruction	○	○	—

Output signal

Actuator status	Symbol			
	OUT1	OUT2	OUT3	OUT4
Completion of motor side end positioning	○	○	—	—
Completion of end positioning	○	—	○	—
Completion of intermediate 1 positioning	○	—	—	○
Completion of intermediate 2 positioning	○	○	—	○
Completion of intermediate 3 positioning	○	—	○	○
Completion of external input stop	○	○	○	—

○ indicates on status, and — indicates off status.

NPN input/output circuit

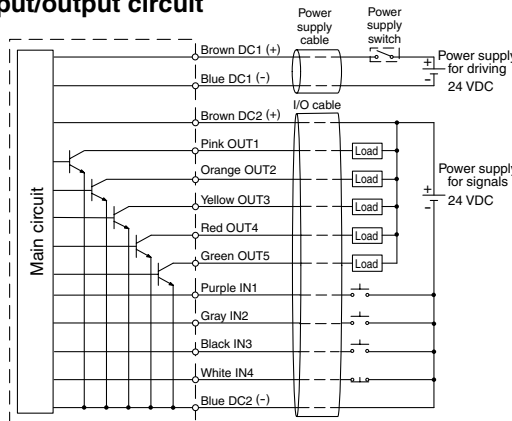

PNP input/output circuit

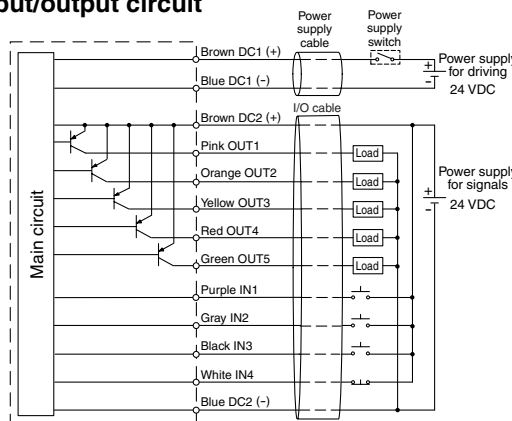

- LJ1
- LG1
- LTF
- LC1
- LC7
- LC8
- LXF
- LXP
- LXS
- LC6□
- LZ□
- LC3F2
- X□
- D-□
- E-MY

Error Display and Problem Solving

When the error indicator is displayed, refer to the following instructions.



Item	Display	Contents	Solution
Emergency stop		Either the emergency stop input is opened, or the power supply for the signal is cut-off.	Confirm the power supply signal is energized and release the emergency stop input. (Refer to the circuit diagram on page 1141.)
Abnormal external output		External output is short-circuited.	In case of common power supply, turn off the power supply and check the wiring condition of load. Restart the power supply. (Refer to the circuit diagram on page 1141.)
		* There is no external output signal.	In case of an independent power supply, turn off the power supply for the signals and check the wiring condition of load. Restart the power supply. (Refer to the circuit diagram on page 1141.)
Power supply abnormality		The power supply voltage is excessive or lower than the limit for operation.	Check the power supply voltage and adjust it if necessary, then press the MIDDLE button.
Drive abnormality		Maximum output is continued for a prolonged period of time.	Check the work weight and confirm that no foreign materials are attached to the actuator. After confirming, press the MIDDLE button.
Temperature abnormality		Internal temperature of the controller is high.	Lower the surrounding temperature of the actuator in use, and then press the MIDDLE button.

Item	Display	Contents	Solution
Abnormal stroke		The motor is revolving at excessive speed or stops before target is achieved.	If any foreign materials are observed, remove them and then press the MIDDLE button.
			Check to see whether the stroke adjusting unit is loose. If required, re-adjust the stroke and perform the stroke learning again. (Note 1)
Motor abnormality		The motor does not revolve properly or over current is detected.	In case of using the remote controller type, please confirm the connection of the connector part between the motor and the controller, after turning off the power supply.
			Press the MIDDLE button.
Controller abnormality		The CPU is malfunctioning or the memory content is abnormal.	Turn off the power supply and restart it.
Error of the set value		The switch settings for speed and acceleration have been changed while in a locked condition. * There is no external output signal.	Reset the settings for speed and acceleration to the set values while in a locked condition.

Note 1) The product is in the same condition as when the stroke learning process is completed.

Return to the home position is not performed by the initial input

- If the error can not be corrected, turn off the power supply to stop operation, and contact your SMC sales representative.

Alarm reset

There are two types of alarm reset: alarm reset manually (a) and an alarm reset externally (b) by an external signal.

a: Alarm reset manually

In the event of an alarm, simply pushing (2) will revert from the alarm state.

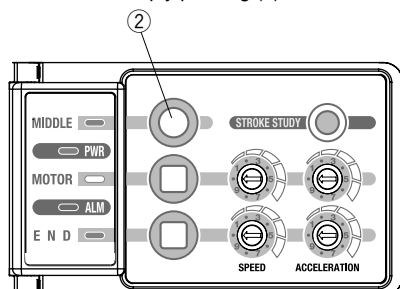

b: Alarm reset externally

In the event of an alarm, simply inputting an external emergency stop signal for 50 ms or longer will return to the state prior to the alarm. The emergency stop output will activate by releasing the input for the emergency stop.

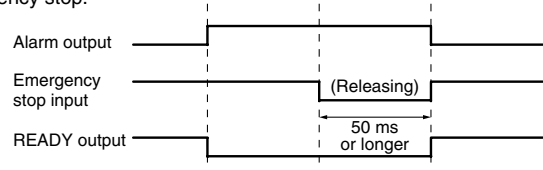

The followings are the reinstated condition.

- The slider will be free until the command for driving is applied.
- After being reverted, the next input command for driving makes it start. The initial motion after being reverted is 50 mm/s of a traveling speed.



Please consult with SMC for detailed dimensions, specifications and delivery.

Made-to-Order Application List

		Intermediate stroke XB10	Long stroke XB11	Helical insert thread X168
E-MY2C	Cam follower guide type	Can be adjusted on a regular basis	Can be adjusted on a regular basis	●
E-MY2H	Linear guide single axis type	●	●	●
E-MY2HT	Linear guide double axis type	●	●	●

1 Intermediate Stroke XB10

Within the standard stroke range, the stroke length in the middle range can be adjusted by 1 mm increments. (The intermediate stroke is available as a standard spec with the E-MY2C.)

■ Stroke range: 51 to 599 mm

E-MY2H Refer to the standard model no. on page 1132 -XB10

Example) E-MY2H25-599TAN-M9B-XB10

2 Long Stroke XB11

Available with long strokes exceeding the standard stroke range.

The stroke length can be adjusted by 1 mm increments. (The E-MY2C is available with an up to 1,000-mm stroke as a standard spec.)

■ Stroke range: 601 to 1000 mm

E-MY2H Refer to the standard model no. on page 1132 -XB11

Example) E-MY2H25-999TAN-M9B-XB11

3 Helical Insert Thread Specifications X168

The mounting threads of the slider are changed to helical insert threads. The thread size is standard size.

E-MY2 Refer to the standard model no. on page 1126, 1132 -X168

Example) E-MY2H25-300TAN-M9B-X168

Others: Made to Order / For detail, please contact SMC.

● 6-point stoppable type

Stoppable at both ends (2-point) and at intermediate strokes (4-point)

● Max. manufacturable stroke

Stroke exceeding 1000 mm is available.

Nominal size	E-MY2C	E-MY2H	E-MY2HT
16	2000	1000	1000
25	2000	1500	1500

Maximum thrust is reduced depending on the stroke.

Max. thrust = Max. payload x Max. acceleration

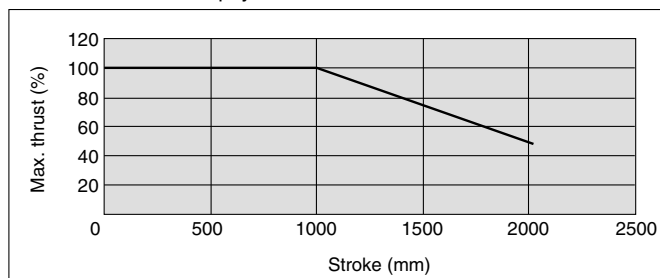

LJ1

LG1

LTF

LC1

LC7

LC8

LXF

LXP

LXS

LC6□

LZ□

LC3F2

X□

D-□

E-MY



Series E-MY2 e-Rodless Actuators Precautions 1

Be sure to read before handling.

Design and Selection

Warning

1. Conduct operation at regulated voltage.

The product may not function correctly or the controller section may be damaged if used with any other voltage than the specified regulated voltage. If the regulated voltage is low, the load may not operate due to internal voltage drop of the controller section. Check and confirm the operating voltage before using.

2. Do not use a load that is over the maximum load volume.

The controller section may be damaged.

3. Operate within the limit of the specification range.

If operated outside of the specification range, there is a possibility of fire, malfunction, and or actuator damage. Operate after confirming the required specifications.

4. To prevent any damage by product failure or malfunction, plan and construct a backup system beforehand, such as multiplexing the components and equipment, employing failure free planning, etc.

5. Provide enough space for maintenance.

When planning, consider the space required for product checkup and maintenance.

6. Provide a protective cover when there is a risk of human injury.

If a driven object and or moving parts of a cylinder pose a danger to human injury, design the structure to avoid contact with the human body.

7. Securely tighten all mounting parts and connecting parts of the actuator to prevent them from becoming loose.

In particular, when a cylinder operates at a high frequency, or is installed where there is excessive vibration, ensure that all parts remain secure.

8. Do not apply more load than stipulated by the spec.

[kg]

Load spec. Nominal size	Heavy load	Standard load	Medium load	Light load
16	10	5	2.5	1.25
25	20	10	5	2.5

9. The resistance value of the attached equipment should be within the allowable external resistance value.

Mounting

Caution

1. Do not drop, strike, or apply excessive shock to the actuator.

The actuator could be damaged, resulting in its failure and or malfunction.

2. Hold the body when handling.

The actuator could be damaged, resulting in its failure and or malfunction.

Mounting

Caution

3. Keep tightening torque.

If tightened beyond the specified range, damage may occur. In addition, if tightened below the specified range, the actuator installation position may shift to some extent.

4. Do not install the actuator in a location used as a scaffold for work.

By stepping on the actuator, the actuator may receive excessive load weight which may damage it.

5. Provide a flat surface for installing the actuator and workpiece. The degree of surface flatness should be determined by the machine precision requirement, or its corresponding precision.

Keep actuator mounting surface flatness within 0.1/500 mm. The degree of surface flatness for mounting a workpiece should be within 0.02 mm.

6. Attaching and detaching the cylinder body

To remove the cylinder body, remove the four cylinder holding bolts and remove the cylinder from the guide unit. To install the cylinder, insert its slider into the slide table on the guide unit and equally tighten the four holding bolts. Tighten the holding bolts securely because if they become loose, problems may occur such as damage, malfunction, etc.

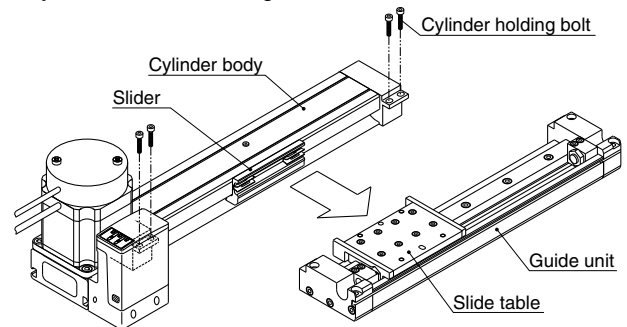

7. Workpiece mounting

When mounting a magnetic workpiece, keep a clearance of 5 mm or greater between the auto switch and the workpiece. Otherwise, the magnetic force within the cylinder may be lost, resulting in malfunction of the auto switch.

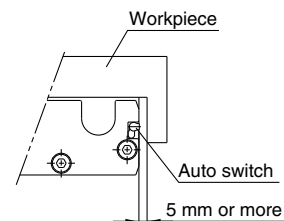

Wiring

Warning

1. Avoid repeatedly bending and/or stretching the cables.

Repeatedly applying bending stress and stretching force to the cables may result in broken lead wires.

2. Avoid incorrect wiring.

Depending on the type of incorrect wiring, the controller section may be damaged.



Series E-MY2 e-Rodless Actuators Precautions 2

Be sure to read before handling.

Wiring

Warning

3. Perform wiring when the power is off.

The controller section may be damaged and malfunction.

4. Do not wire with power lines or high voltage lines.

Conduct wiring for controller separately from power lines or high voltage lines to avoid interference from the noise or surge from the signal lines of the power lines or high voltage lines. This may result in malfunction.

5. Confirm that the wiring is properly insulated.

Be certain that there is no faulty wiring insulation (contact with other circuits, improper insulation between terminals, etc.) because the controller may be damaged due to excessively applied voltage or current flow to the controller section.

6. Be sure to attach a noise filter when a remote control type, CE compliant product is used.

Using without a noise filter will be a non-CE compliant product.

Operating Environment

Warning

1. Do not use in a place where the product may come in contact with dust, particles, water, chemicals and oil.

It may cause damage and malfunction.

2. Do not use in a place where a magnetic field is present.

It may cause malfunction to the actuator.

3. Do not use the product in the presence of flammable, explosive or corrosive gas.

It may cause fire, explosion, and corrosion. The actuator does not have an explosion proof construction.

4. Do not use in an environment subjected to temperature cycle.

If used in an environment where temperature cycling occurs, other than the usual temperature change, the internal controller may be adversely effected.

5. Do not use in a place that has excessive electrical surge generation, even though this product is compliant with CE marking.

When there are units (solenoid type lifter, high frequency induction furnace, motor, etc.) which generate a large amount of surge in an area around the controller, deterioration or damage may occur to the internal circuit elements of the controller. Avoid sources of surge generation and crossed lines.

6. Select a product type that has built-in surge absorbing elements for a load, such as relays or solenoid valves which are employed for driving voltage generating load directly.

7. Install the actuator in a place without vibration and impact.

Vibration and impact causes damage and malfunction to the product and work, as well as prevents the work from meeting the specified parameters.

Adjustment and Operation

Warning

1. Do not short the loads.

Short on the load of the controller indicates an error, but it may cause over current and damage the controller.

2. Do not operate or conduct any settings with wet hands.

An electrical shock may result from wet hands.

3. When operating the controller, avoid making contact with the workpiece.

Contact with the workpiece may cause injury.

Caution

1. Do not push the setting buttons with sharp pointed items.

Sharp pointed items may cause setting button damage.

2. Do not touch the sides and lower parts of the motor and controller.

Conduct operation after confirming that the machine is cool since it gets hot while in operation.

3. After the stroke is adjusted, turn on the power supply and then perform stroke learning.

If stroke learning is not performed, the product may not operate according to the adjusted stroke and damage to any connected equipment may occur.

4. Do not randomly change the guide adjusting section setting.

Readjustment of the guide is not necessary for normal operation, since it is pre-adjusted. Accordingly, do not randomly change the guide adjusting section setting.

Maintenance

Warning

1. Periodically perform maintenance of the product.

Confirm that the piping and bolts are securely tightened. Unintentional malfunction of a system's components may occur as a result of an actuator malfunction.

2. Do not disassemble, modify (including change of printed circuit board) or repair.

Disassembly or modification may result in injury or failure.

Caution

1. Confirm the range of movement of a workpiece (a slider) before connecting the driving power supply or turning on the switch.

The movement of the work may cause an accident. When the power supply is turned on, the work is returned to home position by input IN1 or IN2 signal. (Except in the case when stroke learning is not performed ever).

LJ1

LG1

LTF

LC1

LC7

LC8

LXF

LXP

LXS

LC6□

LZ□

LC3F2

X□

D-□

E-MY

e-Rodless Actuator

Series E-MY2B

Suitable for light-load transfers.
Combined with various guide types.

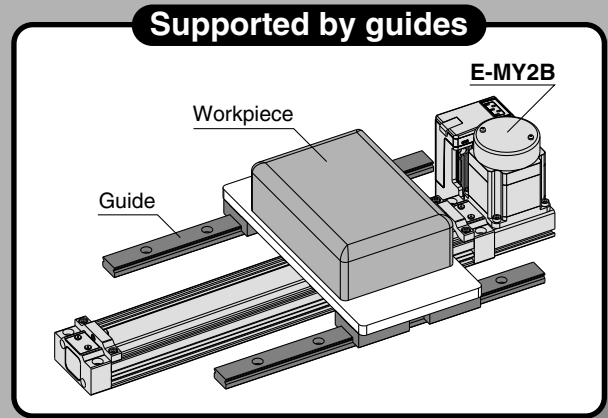
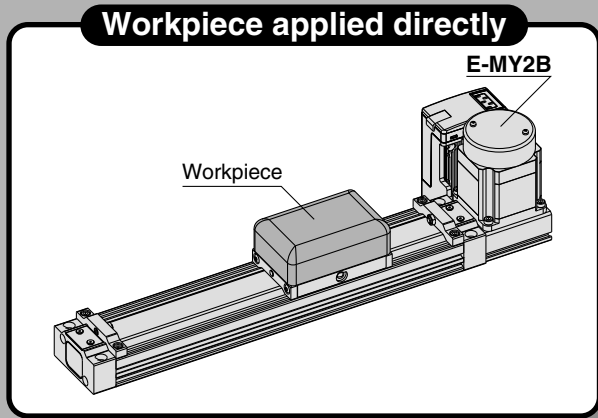

e-Rodless Actuator/Basic Type



e-Actuator

LJ1

LG1

LTF

LC1

LC7

LC8

LXF

LXP

LXS

LC6□

LZ□

LC3F2

X□

D-□

E-MY

Floating Bracket

Easy connection to an external guide. Two mounting directions are available.

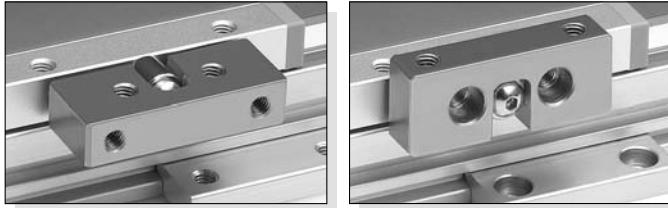

Stroke Adjusting Unit

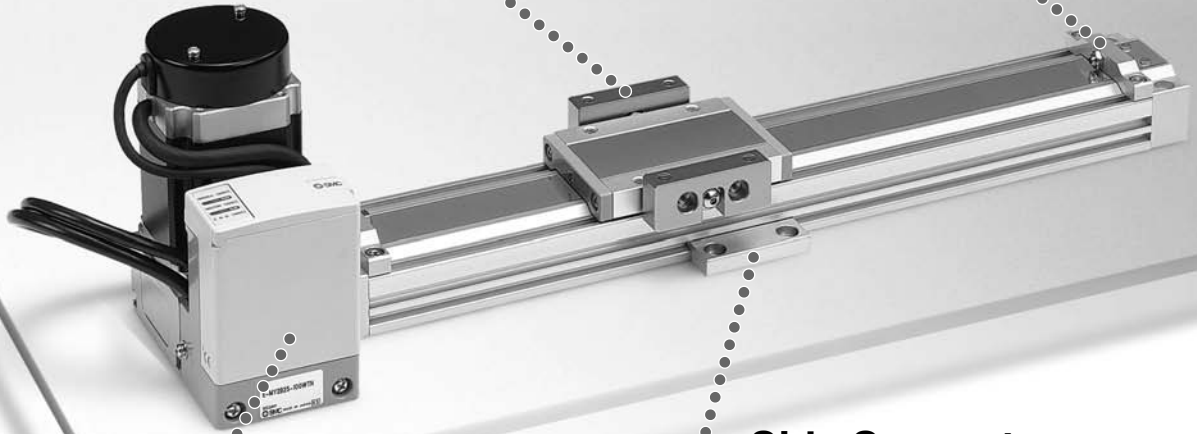

Controller No Programming Required

Realizes similar controllability by simple commands as a pneumatic cylinder.

Automatic operation
Operable by the same signals (PLC) as the solenoid valve.

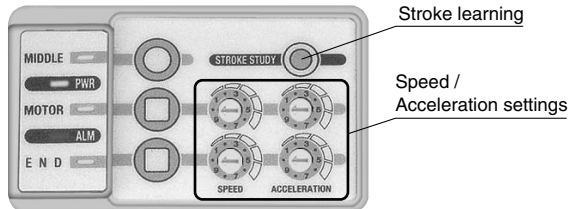

Side Support

The cylinder tube can be fixed from upward or downward.

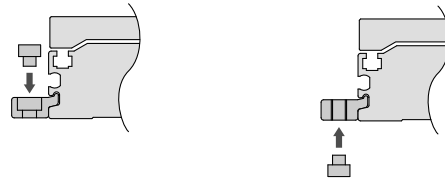
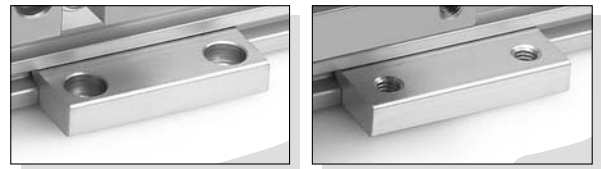

Speed / Acceleration Specifications

Speed Variation (mm/s)

		Low speed	Medium speed	Standard speed
Main adjustment range		10 to 100	50 to 300	100 to 1000
Switch turned NO.	1	10	50	100
	2	20	75	200
	3	30	100	300
	4	40	125	400
	5	50	150	500
	6	75	200	600
	7	100	250	700
	8	300	300	800
	9	500	500	900
	10	1000	1000	1000

Load Spec. and Acceleration Variation (kg)

		Payload	Heavy load	Standard load	Medium load	Light load
Nominal size	16	6 (10)	4 (5)	2.5 (2.5)	1.25 (1.25)	
	25	11 (20)	8 (10)	4 (5)	2.5 (2.5)	
Acceleration						
Switch turned NO.	1	0.25	0.49	0.98	1.96	
	2	0.49	0.74	1.47	3.94	
	3	0.74	0.98	1.96	3.92	
	4	0.98	1.23	2.45	4.90	
	5	1.23	1.47	2.94	5.88	
	6	1.47	1.96	3.92	7.84	
	7	1.72	2.45	4.90	9.80	
	8	1.96	2.94	5.88	11.76	
	9	2.21	3.92	7.84	15.68	
	10	2.45	4.90	9.80	19.60	

(): Using a guide externally.

Remote Control Type

Easy to reset after installation as a result of the remote controller.

Suited for installing where it is difficult to reach because the controller can be operated in an easily accessible location.

- Cable length is selectable from 1 m, 3 m and 5 m.
- Improvement in the maximum operating temperature from 40°C to 50°C (Actuator unit only)
- Mounting method can be selected among 3 types.

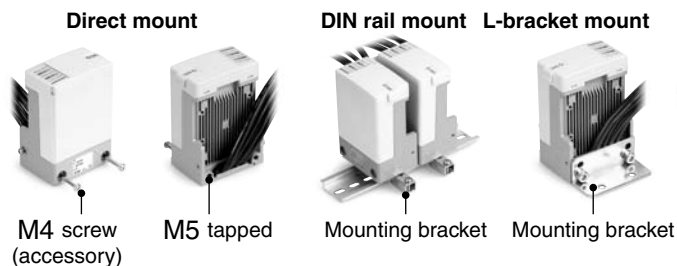

Intermediate Stop

3-point stoppable type

(2-point for both ends and 1-point for an intermediate stop)

One intermediate stop is possible beside stops at both ends.

5-point stoppable type

(2-point for both ends and 3-point for an intermediate stop)

5-point positioning is possible at any preferred locations.

3-point stoppable type



5-point stoppable type (with streamer)

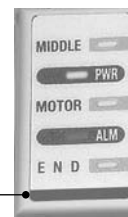

Stop Functions by External Inputs (5-point stoppable type only)

Stop command by an external input such as a PLC or PC makes it possible to decelerate or stop a slider (as programmed).

Application example 1

Quick start-up is possible after stopping.

Stop method	Stop by external inputs	Emergency stop
Stopping acceleration (deceleration speed)	Value of a switch for setting acceleration	4.9 m/s ²
Initial motion speed after stopping	Value of a switch for speed	50 mm/s

* Settings for emergency acceleration and speed cannot be changed.

Repeatability of stop functions by external stop

Travelling speed (mm/s)	100	500	1000
Repeatability (mm)	±0.5	±1.0	±2.0

Note) The valves shown are to be used as a selection guide and are not guaranteed.

Application example 2

Signal from auto switches on the e-rodless actuator can make it decelerate or stop.

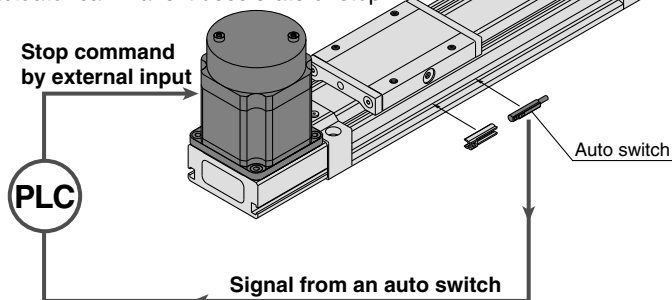

Motor Placement: Mounting position of the motor is user selectable and can either be on the top or bottom of the actuator.

Locking Functions

Settings for speed/acceleration can be locked.

If the speed/acceleration switch is changed in the middle of locking, the alarm light will blink. However, the motion will continue in accordance with the preprogrammed settings.

* Settings for locking a stroke and intermediate position are not applicable.

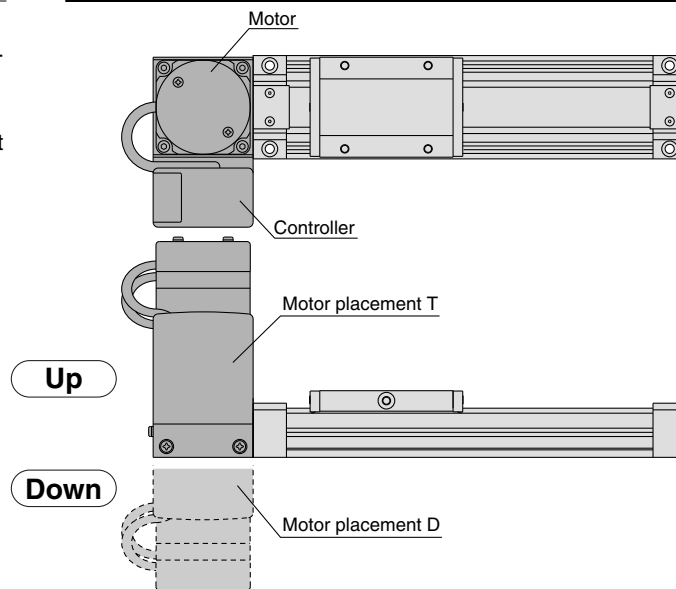
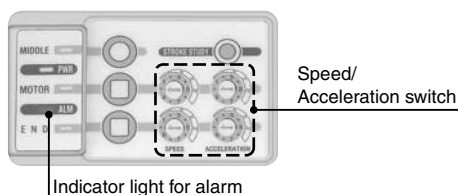

LJ1

LG1

LTF

LC1

LC7

LC8

LXF

LXP

LXS

LC6□

LZ□

LC3F2

X□

D-□

E-MY

Series E-MY2B Model Selection 1

For e-rodless actuator series E-MY2C/H/HT, refer to page 1113.

Selection Flow Chart

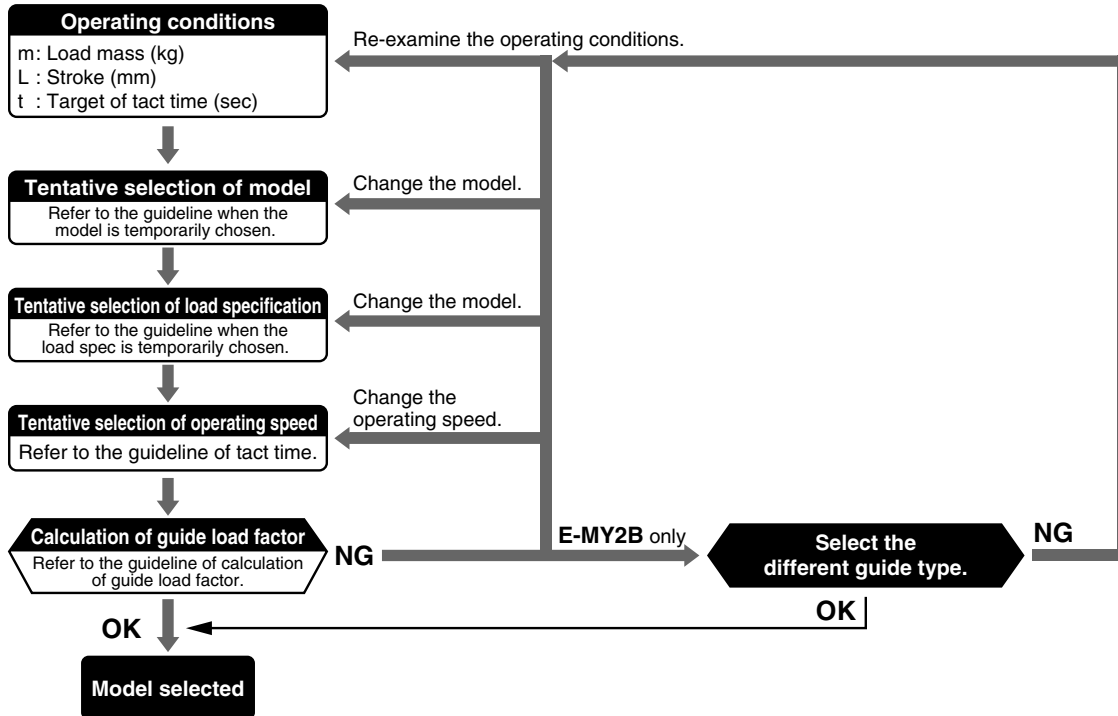

Guideline for Tentative Model Selection

Model	Type	Guideline for tentative model selection						Note
		Stroke accuracy	Use of other guide	Direct loaded (Horizontal)	Table ^{Note)} accuracy	Direct mount (Wall mounting)	Load resistance / Moment resistance	
E-MY2B	Basic type	◎	◎	○	△	△	△	Light-load transfer; combining with another guide; stroke accuracy is required.
E-MY2C	Cam follower guide type	◎	×	◎	◎	○	○	Workpiece direct mounting; table and stroke accuracy are required.
E-MY2H	Linear guide single axis type	◎	×	◎	◎	◎	○	Workpiece direct mounting without restriction of mounting direction; table and stroke accuracy are required.
E-MY2HT	Linear guide double axis type	◎	×	◎	◎	◎	◎	Workpiece direct mounting without restriction of mounting direction; table and stroke accuracy are required especially when a heavy load or moment is applied.

◎ Most suitable ○ Suitable △ Usable × Not recommended
 Note) The table accuracy means the amount of table deflection when a moment is applied.

Guideline for when the load spec is temporarily chosen.

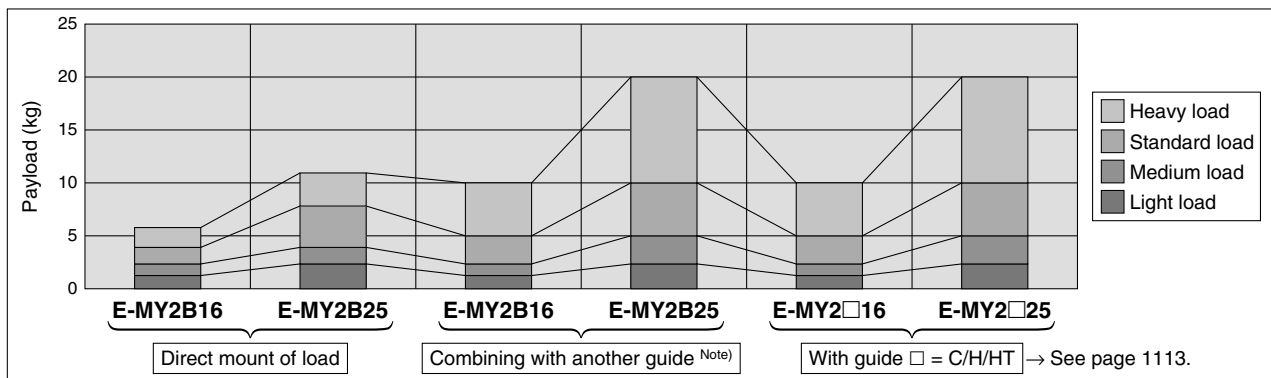

Note) Friction coefficient for combining with another guide is 0.1 or less.

Guide Tact Time

Heavy load specifications (2.45 m/s²)

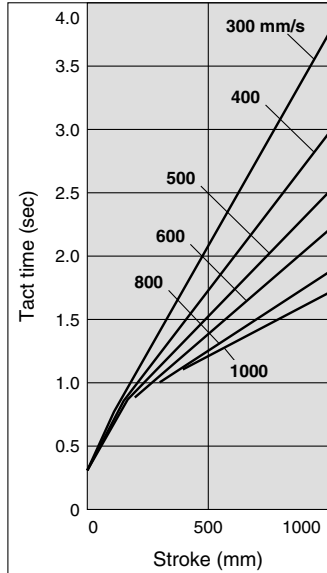

Standard load specifications (4.90 m/s²)

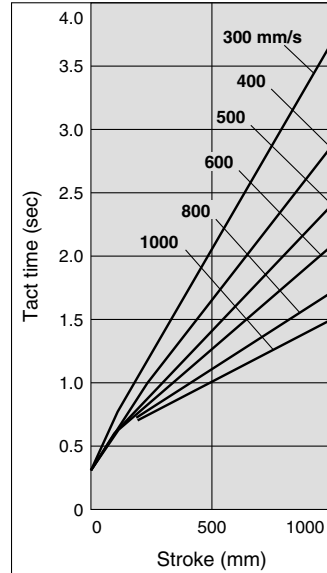

Medium load specifications (9.80 m/s²)

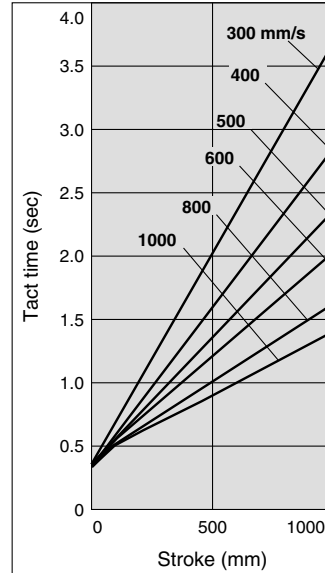

Light load specifications (19.60 m/s²)

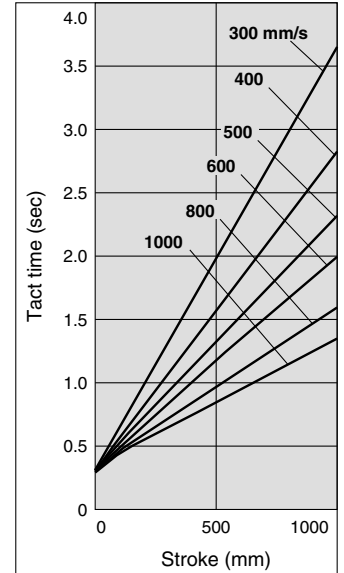

Note) Tact time may vary depending on the load mass or sliding resistance and thus value is not guaranteed.

Calculation of Guide Load Factor

1. Maximum allowable load (1), static moment (2), and dynamic moment (at the time of impact with stopper) (3) must be examined for the selection calculations.

* To evaluate, use \bar{v}_a (average speed) for (1) and (2), and v (impact speed $v = 1.4 \bar{v}_a$) for (3). Calculate m_{max} for (1) from the maximum load mass (m_1, m_2, m_3) and M_{max} for (2) and (3) from the maximum allowable moment graph (M_1, M_2, M_3).

$$\text{Sum of guide load factors } \Sigma \alpha = \frac{\text{Load mass [m]}}{\text{Maximum load mass [m max]}} + \frac{\text{Static moment [M] }^{Note 1}}{\text{Allowable static moment [Mmax]}} + \frac{\text{Dynamic moment [ME] }^{Note 2}}{\text{Allowable dynamic moment [MEMax]}} \leq 1$$

Note 1) Moment caused by the load, etc., with actuator in resting condition.

Note 2) Moment caused by the impact load equivalent at the stroke end (at the time of collision to stopper).

Note 3) Depending on the shape of the workpiece, multiple moments may occur. When this happens, the sum of the load factors ($\Sigma \alpha$) is the total of all such moments.

2. Reference formulas [Dynamic moment at impact]

Use the following formulas to calculate dynamic moment when taking stopper impact into consideration.

m : Load mass (kg)

F : Load (N)

F_E : Load equivalent to impact (at impact with stopper) (N)

a : Set acceleration (m/s²)

v : Impact speed (mm/s)

M : Static moment (N·m)

L_1 : Distance to the load's center of gravity (m)

M_E : Dynamic moment (N·m)

$F_E = m \cdot a$

$$\therefore M_E = \frac{1}{3} \cdot F_E \cdot L_1 \text{ (N·m) }^{Note 4}$$

Note 4) Average load coefficient ($= \frac{1}{3}$):

This coefficient is for averaging the maximum load moment at the time of stopper impact according to service life calculations.

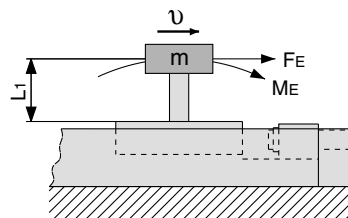

3. Refer to pages 1095 and 1096 for detailed model selection procedures.

Maximum Allowable Moment

Select the moment from within the range of operating limits shown in the graphs. Note that the maximum allowable load value may sometimes be exceeded even within the operating limits shown in the graphs. Therefore, also check the allowable load for the selected conditions.

Maximum Load Mass

Select the load mass from within the range of limits shown in the graphs. Note that the maximum allowable moment value may sometimes be exceeded even within the operating limits shown in the graphs. Therefore, also check the allowable moment for the selected conditions.

The graph value is for calculating the guide load factors. Refer to the table below for actual maximum load mass. The maximum load mass shows the motor ability.

Refer to page 1099 for maximum load mass value.

Caution

Select the required model by taking into consideration the operating condition specifications and any possible specification changes that may occur during operation. Contact the nearest sales representative for SMC's model selection software, which will help in selecting the correct model.

LJ1

LG1

LTF

LC1

LC7

LC8

LXF

LXP

LXS

LC6

LZ

LC3F2

X

D-

E-MY

Model Selection

Types of Load Mass and Moment Applied to Rodless Actuators

Multiple moments may be generated depending on the mounting orientation, load, and position of the center of gravity.

Coordinates and moments

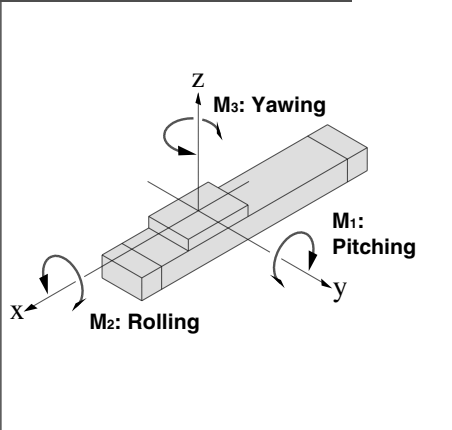

Load mass and static moment

Horizontal mounting

Ceiling mounting

Wall mounting

Mounting orientation	Horizontal mounting	Ceiling mounting	Wall mounting
Static load (m)	m_1	m_2	m_3
Static moment	M_1	$m_2 \times g \times X$	—
	M_2	$m_1 \times g \times Y$	$m_3 \times g \times Z$
	M_3	—	$m_3 \times g \times X$

g: Gravitational acceleration (9.8 m/s²)

Dynamic moment

a: Set acceleration degree, **∪:** Set speed

Mounting orientation	Horizontal mounting	Ceiling mounting	Wall mounting
Dynamic load (Fe)	$m_n \times a$		
Dynamic moment	M_{1E}	$\frac{1}{3} \times F_E \times Z$	—
	M_{2E}	Dynamic moment M_{2E} does not occur.	
	M_{3E}	$\frac{1}{3} \times F_E \times Y$	—

Note) Regardless of the mounting orientation, dynamic moment is calculated with the formulas above.

E-MY2B/m₁, m₂, m₃

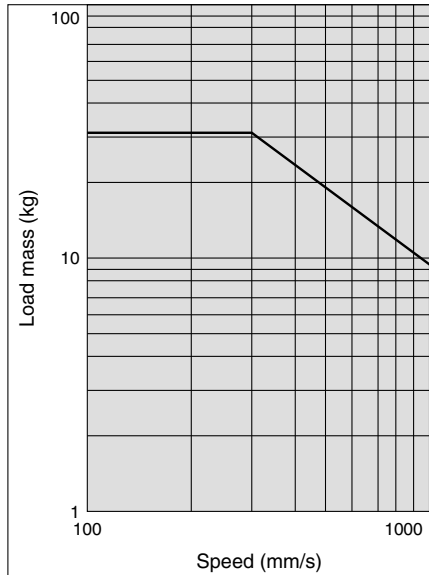

E-MY2B/M₁, M₃

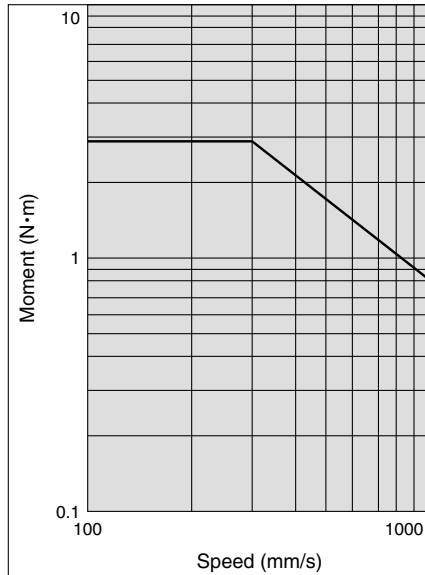

E-MY2B/M₂

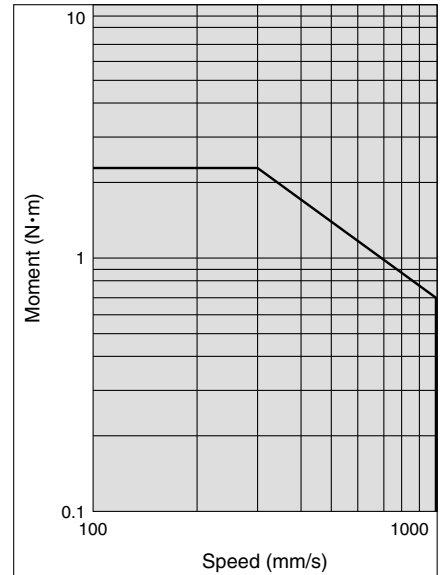

Series E-MY2B Model Selection 2

The following are steps for selection with series E-MY2B best suited for your application.

Calculation of Guide Load Factor

1 Operating Conditions

Operating cylinder **E-MY2B16-500**
 Set speed v **600 mm/s** Note)
 Set acceleration degree a **4.9 m/s²** Note)
 Mounting orientation **Horizontal mounting**

Note) Regarding the speed and acceleration setting, select from the speed/acceleration chart on page 1099.

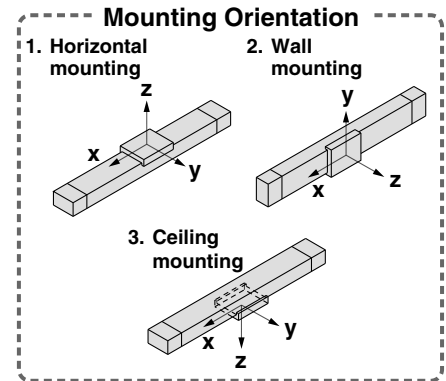
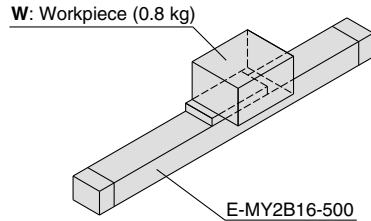

2 Load Blocking

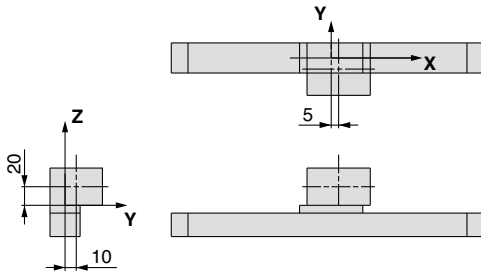

Mass and Center of Gravity for Workpiece

Work-piece no.	Mass (m)	Center of gravity		
		X-axis	Y-axis	Z-axis
W	4 kg	5 mm	10 mm	20 mm

3 Calculation of Load Factor for Static Load

m₁: Mass

m_1 max (from 1 of graph m_1) = 15.5 (kg)
 Load factor $\alpha_1 = m_1 / m_1 \text{ max} = 4 / 15.5 = \mathbf{0.26}$

M₁: Moment

M_1 max (from 2 of graph M_1) = 1.45 (N·m)
 $M_1 = m_1 \times g \times X = 4 \times 9.8 \times 5 \times 10^{-3} = 0.20$ (N·m)
 Load factor $\alpha_2 = M_1 / M_1 \text{ max} = 0.20 / 1.45 = \mathbf{0.14}$

M₂: Moment

M_2 max (from 3 of graph M_2) = 1.15 (N·m)
 $M_2 = m_1 \times g \times Y = 4 \times 9.8 \times 10 \times 10^{-3} = 0.39$ (N·m)
 Load factor $\alpha_3 = M_2 / M_2 \text{ max} = 0.39 / 1.15 = \mathbf{0.34}$

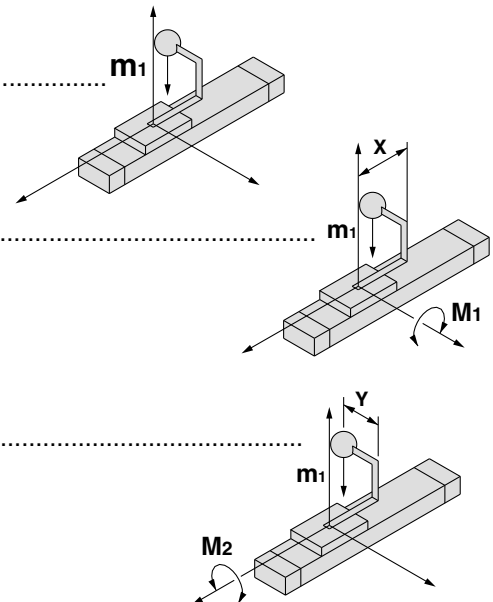

LJ1

LG1

LTF

LC1

LC7

LC8

LXF

LXP

LXS

LC6□

LZ□

LC3F2

X□

D-□

E-MY

Model Selection

Calculation of Guide Load Factor

4 Calculation of Load Factor for Dynamic Moment

Load F_E at acceleration and deceleration

$$F_E = m \times a = 4 \times 4.9 = 19.6 \text{ (N)}$$

M_{1E} : Moment

$$M_{1E \text{ max}} \text{ (From 4 of graph } M_1 \text{ at } 600 \text{ mm/s)} = 1.45 \text{ (N}\cdot\text{m)} \dots\dots\dots$$

$$M_{1E} = \frac{1}{3} \times F_E \times Z = \frac{1}{3} \times 19.6 \times 20 \times 10^{-3} = 0.13 \text{ (N}\cdot\text{m)}$$

$$\text{Load factor } \alpha_4 = M_{1E} / M_{1E \text{ max}} = 0.13 / 1.45 = \mathbf{0.09}$$

M_{3E} : Moment

$$M_{3E \text{ max}} \text{ (From 5 of graph } M_3 \text{ at } 600 \text{ mm/s)} = 1.45 \text{ (N}\cdot\text{m)} \dots\dots\dots$$

$$M_{3E} = \frac{1}{3} \times F_E \times Y = \frac{1}{3} \times 19.6 \times 10 \times 10^{-3} = 0.07 \text{ (N}\cdot\text{m)}$$

$$\text{Load factor } \alpha_5 = M_{3E} / M_{3E \text{ max}} = 0.07 / 1.45 = \mathbf{0.05}$$

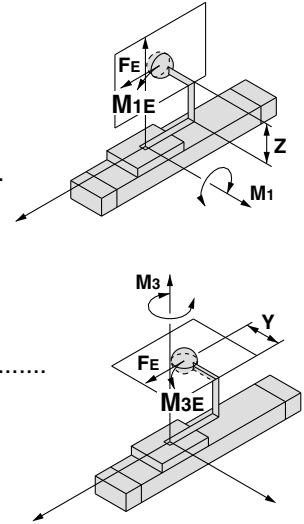

5 Sum and Examination of Guide Load Factors

$$\Sigma\alpha = \alpha_1 + \alpha_2 + \alpha_3 + \alpha_4 + \alpha_5 = 0.26 + 0.14 + 0.34 + 0.09 + 0.05 = 0.88 \leq 1$$

The above calculation is within the allowable value and therefore the selected model can be used.

In an actual calculation, when sum of guide load factors $\Sigma\alpha$ in the formula above is more than 1, consider decreasing the speed or changing the product series.

Load Mass

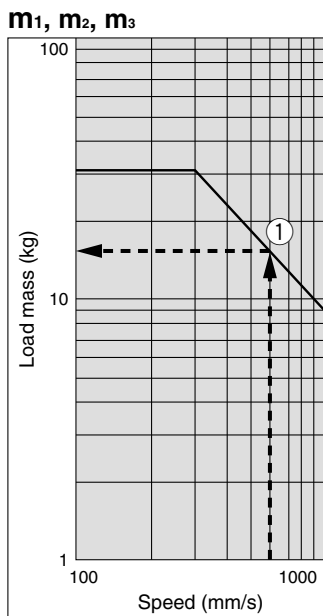

Allowable Moment

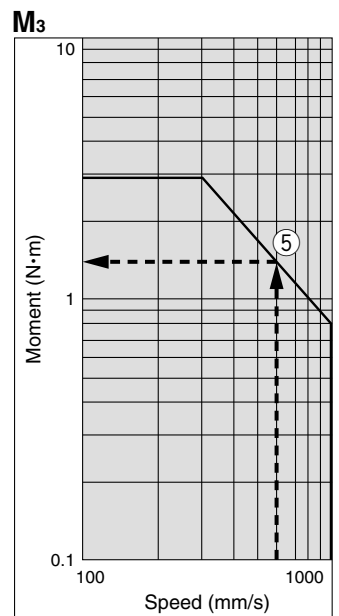
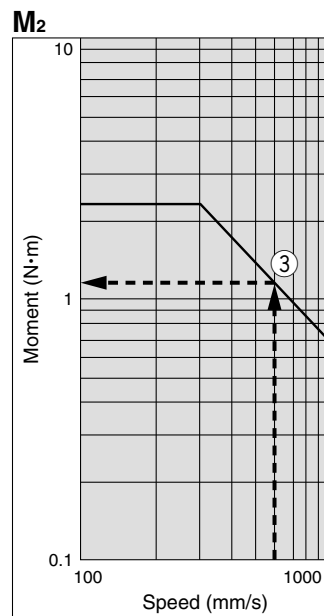
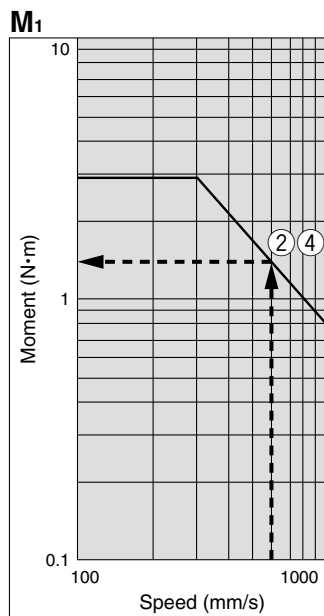

e-Rodless Actuator

Series E-MY2B



Basic Type / Nominal Size: 16, 25

How to Order

Integrated control type E-MY2B 16 [] [] - 100 W T N [] — M9BW [] — []

Remote control type E-MY2B 16 [] [] - 100 W T N [] M - M9BW [] - [] - []

Nominal size

16
25

Speed specifications * [mm/s]

	L	M	Nil
Low	10 to 1000	50 to 1000	100 to 1000

* Standard type is not available for high speed.

Stroke
Refer to "Standard Stroke" table.

Stroke adjusting unit

Nil	None
M	Motor side only
E	End side only
W	Both sides

Motor placement

T	On the top
D	On the bottom

Output type

N	NPN
P	PNP

Number of stoppable positioning points

Nil	3-point stoppable type
A	5-point stoppable type

Auto switch

Nil	Without auto switch (built-in magnet)
Nil	2 pcs.
S	1 pc.
n	n pcs.

Auto switch

Nil	Without auto switch (built-in magnet)
-----	---------------------------------------

* Refer to the table below for auto switch model numbers.

Cable length

M	1 m
L	3 m
Z	5 m

* The remote control type can be selected by adding the above symbols.

Load specifications * Work load [kg]

Symbol	Load specifications	16	25
D	Light load	1.25 (1.25)	2.5 (2.5)
E	Medium load	2.5 (2.5)	4 (5)
Nil	Standard load	4 (5)	8 (10)
Q	Heavy load	6 (10)	11 (20)

* (): When combined with another guide and the friction coefficient is 0.1 or less.
** For details, refer to "Switch and Speed," "Switch and Acceleration" on page 1099.

Stroke adjusting unit

* Arrow mark shows handling side on controller.

Standard Stroke

Nominal size	Standard stroke (mm)
16, 25	100, 200, 300, 400, 500, 600, 700, 800, 900, 1000

* Strokes are manufacturable in increments of 1 mm, up to 100 to 1000 strokes. (Strokes for less than 100 are not available.)
* When exceeding a 1000 strokes, refer to "Made to Order" on page 1109.

Applicable Auto Switches / For detailed auto switch specifications, refer to page 352 through to 402.

Type	Special function	Electrical entry	Indicator light	Wiring (Output)	Load voltage		Auto switch model		Lead wire length (m) *				Pre-wired connector	Applicable load	
					DC	AC	Electrical entry direction		0.5 (Nil)	1 (M)	3 (L)	5 (Z)		IC circuit	Relay, PLC
							Perpendicular	In-line							
Solid state switch	Diagnostic indication (2-color display)	Grommet	Yes	3-wire (NPN)	24 V	5 V	—	M9NV	M9N	●	●	●	○	—	—
				3-wire (PNP)				M9PV	M9P	●	●	●	○		
				2-wire				M9BV	M9B	●	●	●	○		
				3-wire (NPN)				M9NWV	M9NW	●	●	●	○		
				3-wire (PNP)				M9PWV	M9PW	●	●	●	○		
				2-wire				M9BWW	M9BW	●	●	●	○		
Reed switch	—	Grommet	Yes	3-wire (NPN equiv.)	24 V	5 V	100 V	A96V	A96	●	—	●	—	—	—
				12 V				A93V	A93	●	—	●	—		
				5 V, 12 V				A90V	A90	●	—	●	—		

* Lead wire length symbols: 0.5 m Nil (Example) M9N
1 m M M9NWM
3 m L M9NWL
5 m Z M9NWX

* Solid state auto switches marked "○" are produced upon receipt of order.
* For details of auto switches with pre-wired connector, refer to pages 389 and 390.
* Auto switch is shipped together with the cylinder (not assembled).

Basic Specifications



Made to Order
(For details, refer to page 1109.)

Symbol	Specifications
X168	Helical insert thread specifications

Mass

Actuator Unit Unit: kg

Nominal size	Basic mass	Additional mass per 50 mm stroke	Stroke adjusting unit mass (per unit)
16	1.61	0.09	0.02
25	2.04	0.09	0.02

Remote Controller Unit Unit: kg

Controller body	Cable length		
	1 m	3 m	5 m
0.24	0.09	0.24	0.39

How to calculate/Example: **E-MY2B25-300WTNM**

Actuator unit

Basic mass 2.04 kg
 Additional mass 0.09/50 st
 Actuator stroke 300 st
 Unit mass 0.02 g
 $2.04 + 0.09 \times 300 \div 50 + 0.02 \times 2 = 2.62$ kg

Remote controller unit

Controller body 0.24 kg
 Cable length (3 m) 0.24 kg
 $0.24 + 0.24 = 0.48$ kg

* For an integrated control type, add 0.24 kg (controller body) to the basic mass.

Option / Remote Controller Mounting Bracket

Description	Part no.
L-bracket	MYE-LB
DIN rail bracket	MYE-DB

Model		E-MY2B			
Transfer speed set range	Low	10 to 1000 mm/s			
	Medium	50 to 1000 mm/s			
	Standard	100 to 1000 mm/s			
Transfer speed acceleration set range		Heavy load	Standard load	Medium load	Light load
		0.25 to 2.45 m/s ²	0.49 to 4.90 m/s ²	0.98 to 9.80 m/s ²	1.96 to 19.6 m/s ²
Maximum load mass	Note 1), Note 2) Nominal size: 16	6 (10) kg	4 (5) kg	2.5 (2.5) kg	1.25 (1.25) kg
	Nominal size: 25	11 (20) kg	8 (10) kg	4 (5) kg	2.5 (2.5) kg
Acceleration and deceleration method	Trapezoidal drive				
Moving direction	Horizontal direction				
Positioning spots	3-point stoppable type	Both ends (Mechanical stoppers), 1 intermediate position			
	5-point stoppable type	Both ends (Mechanical stoppers), 3 intermediate positions			
Repeated positioning stopping precision	Both ends	± 0.01 mm			
	Intermediate stopping position	± 0.1 mm			
Allowable external resistance	Note 3) Nominal size: 16	10 N			
	Nominal size: 25	20 N			
Intermediate stopping point positioning method	Direct teaching, JOG teaching				
Positioning setting spot	Controller body				
Display	LED for power supply, LED for alarming, LED for positioning completion				
Input signal	Actuation command signal, Emergency stop input signal				
Output signal	Positioning completion signal, Emergency detection signal, Ready signal				

Note 1) The maximum load mass shows the motor ability. Please consider it together with the guide load factor when selecting a model.

Note 2) (): When combined with another guide and the friction coefficient is 0.1 or less.

Note 3) The resistance value of the attached equipment should be within the allowable external resistance value.

Electrical Specifications

Power supply for driving	Power supply voltage	24 VDC ± 10%
	Current consumption	Rated current 2.5 A (Max. 5 A: 2 s or less) at 24 VDC
Power supply for signals	Power supply voltage	24 VDC ± 10%
	Current consumption	30 mA at 24 VDC and Output load capacity
Input signal capacity	6 mA or less at 24 VDC/1 circuit (Photo coupler input)	
Output load capacity	30 VDC or less, 20 mA or less/1 circuit (Open drain output)	
Emergency detection items	Emergency stop, Output deviation, Power supply deviation, Driving deviation, Temperature deviation, Stroke deviation, Motor deviation, Controller deviation	

Environmental Specifications

Operating temperature range	Integrated control type	5 to 40°C
	Remote control type	5 to 50°C
	Actuator unit	5 to 40°C
Operating humidity range	35 to 85%RH (No condensation)	
Storage temperature range	-10 to 60°C (No condensation and freezing)	
Storage humidity range	35 to 85%RH (No condensation)	
Withstand voltage	Between all of external terminals and the case: 500 VAC for 1 minute	
Insulation resistance	Between all of external terminals and the case: 50 MΩ (500 VDC)	
Noise resistance	1000 Vp-p Pulse width 1 μs, Rise time 1 ns	
CE marked	Integrated control type	Standard
	Remote control type	Available with -Q suffixed products only

Speed / Acceleration

Switch no.	Switch and Speed ^{Note 1)} [mm/s]		
	Low speed	Medium speed	Standard speed
1	10	50	100
2	20	75	200
3	30	100	300
4	40	125	400
5	50	150	500
6	75	200	600
7	100	250	700
8	300	300	800
9	500	500	900
10	1000	1000	1000

Switch no.	Switch and Acceleration ^{Note 2)} [m/s ²]			
	Heavy load	Standard load	Medium load	Light load
1	0.25	0.49	0.98	1.96
2	0.49	0.74	1.47	2.94
3	0.74	0.98	1.96	3.92
4	0.98	1.23	2.45	4.90
5	1.23	1.47	2.94	5.88
6	1.47	1.96	3.92	7.84
7	1.72	2.45	4.90	9.80
8	1.96	2.94	5.88	11.76
9	2.21	3.92	7.84	15.68
10	2.45	4.90	9.80	19.60

Note 1) The factory default setting for the switch is No.1.

Note 2) The factory default setting for the switch is No.1.

Series E-MY2B

Dimensions: Integrated Control Type

E-MY2B Nominal size — Stroke

Nominal size: 16

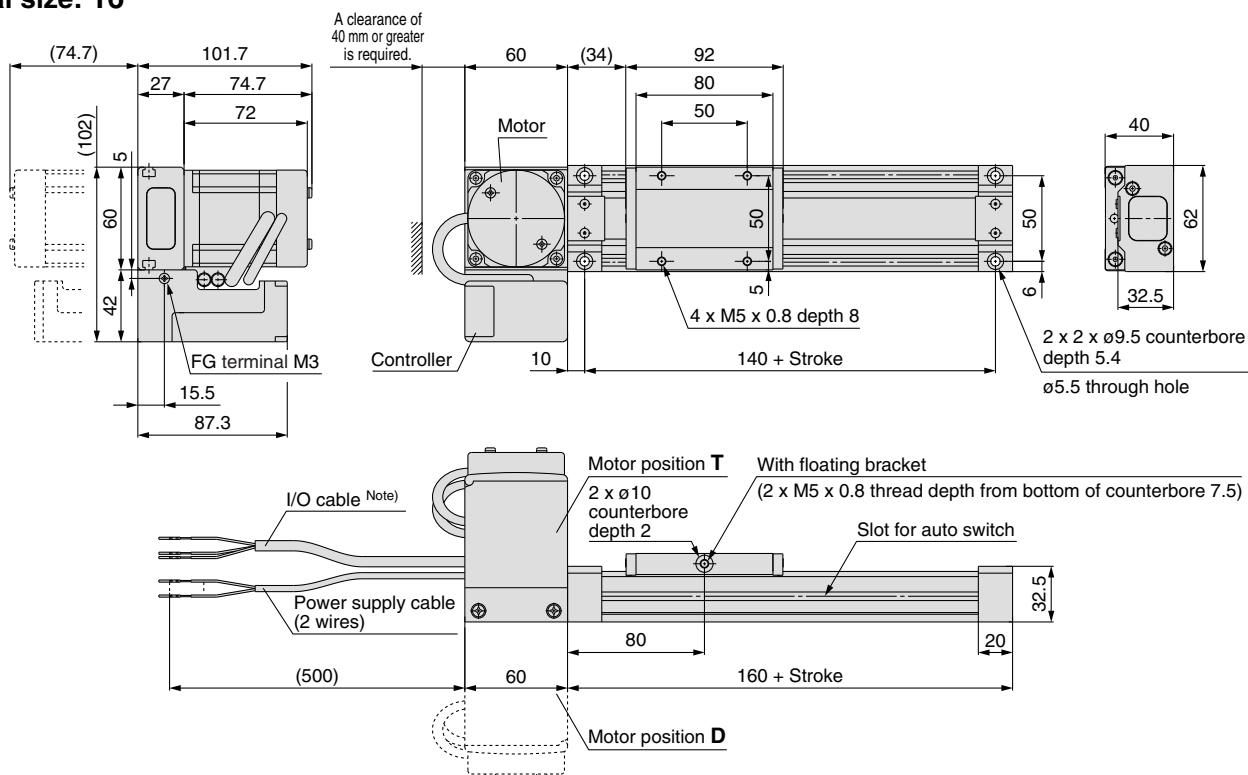

Nominal size: 25

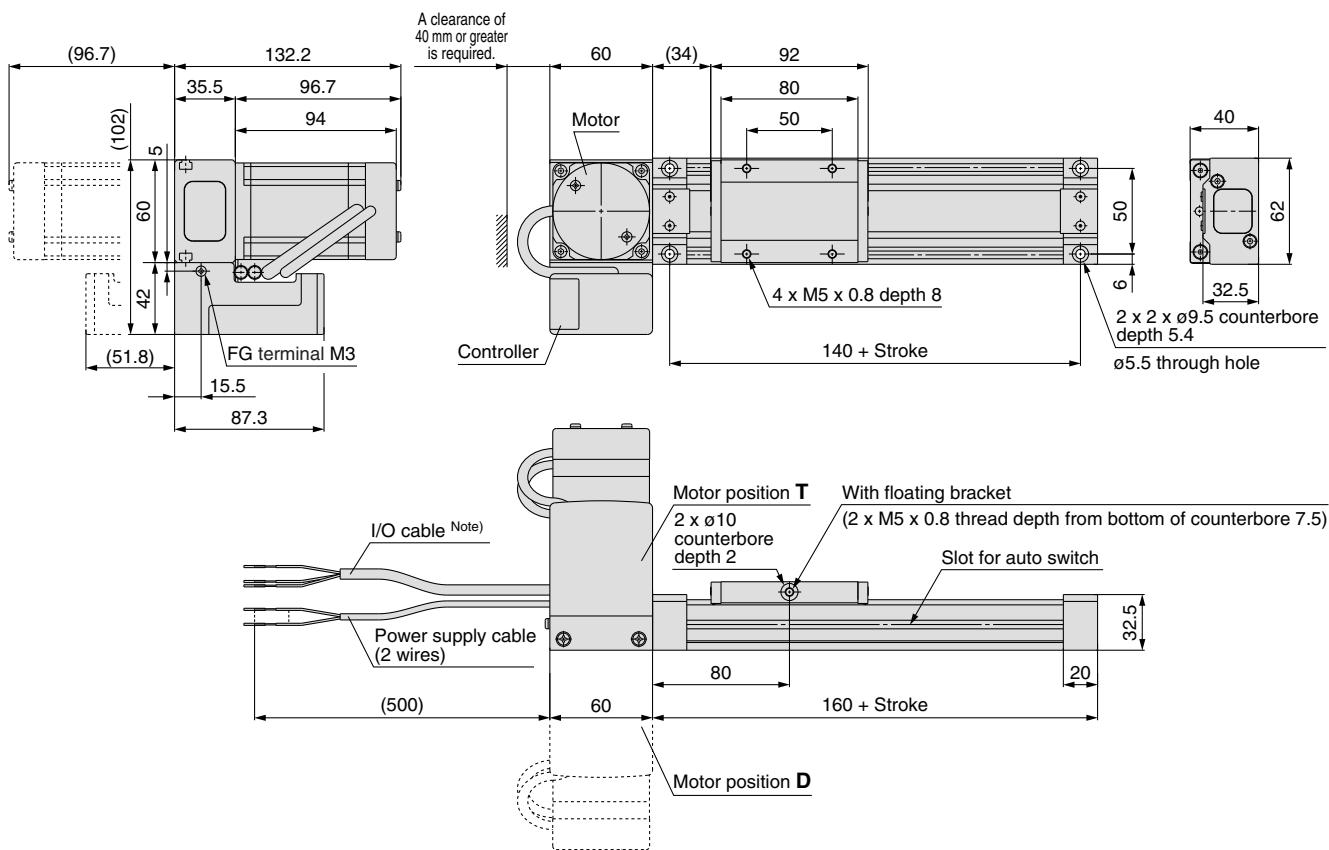

Note) For the 3-point stoppable type, the I/O cable is a 9-core type and for the 5-point stoppable type, a 11-core type is used.

Dimensions: Remote Control Type (Actuator unit)

E-MY2B -

* Refer to page 1102 for dimensions of remote controller.

Nominal size: 16

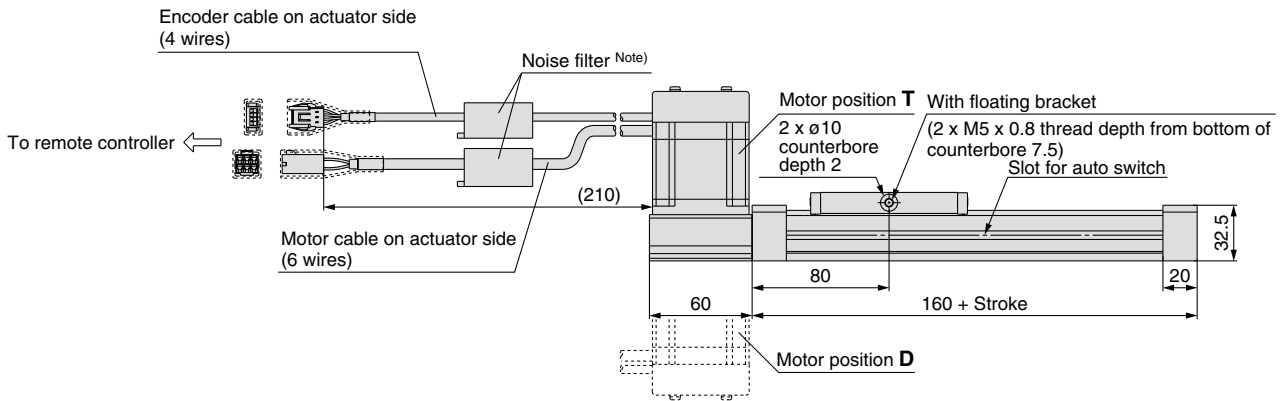
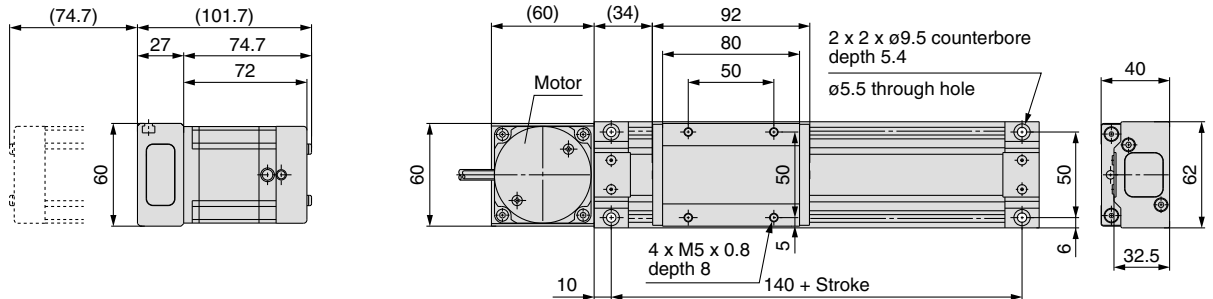

Nominal size: 25

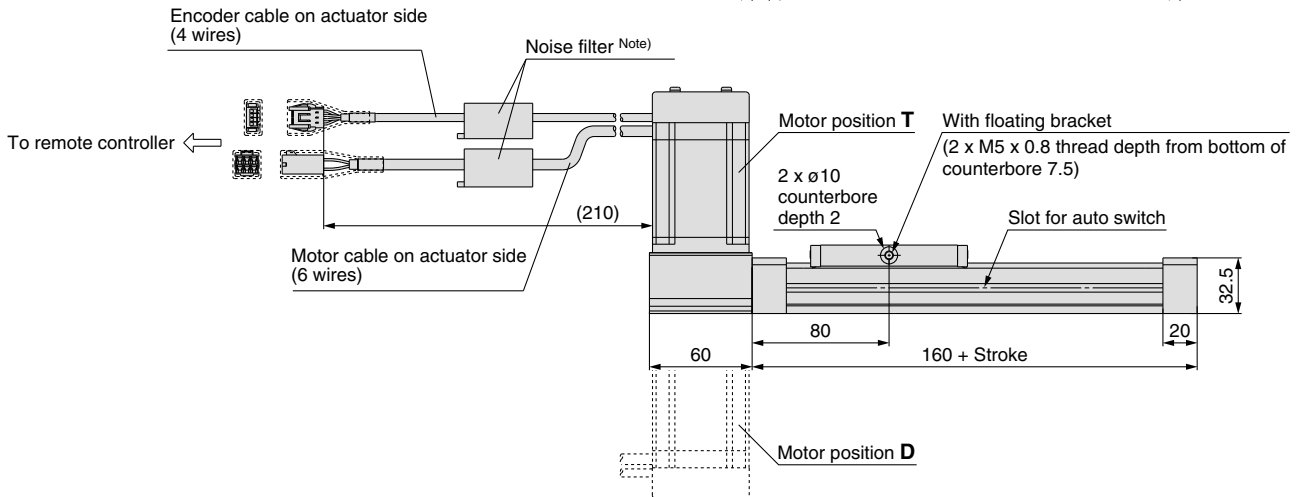
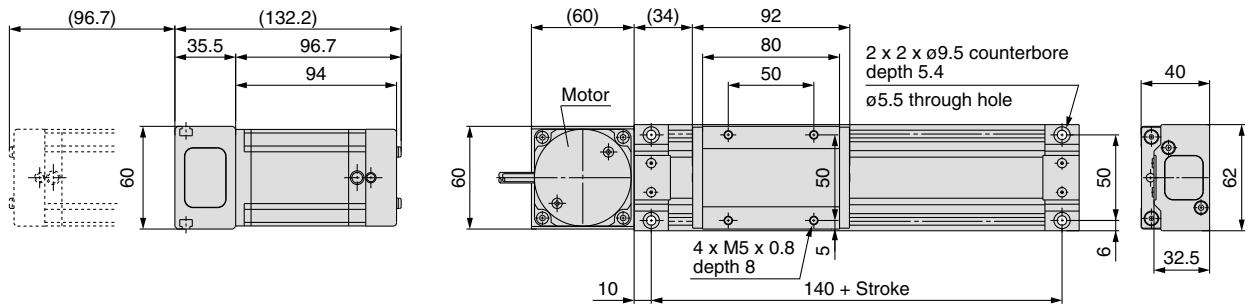

Note) When the CE compliant model is selected, a noise filter is provided but not attached.
The cable for the CE compliant models uses the dedicated shielding. Even if a noise filter is attached to a non CE marked products, the products cannot be changed to a CE compliant product.

LJ1

LG1

LTF

LC1

LC7

LC8

LXF

LXP

LXS

LC6

LZ

LC3F2

X

D-

E-MY

Series E-MY2B

Dimensions: Remote Control Type (Remote controller unit)

Controller

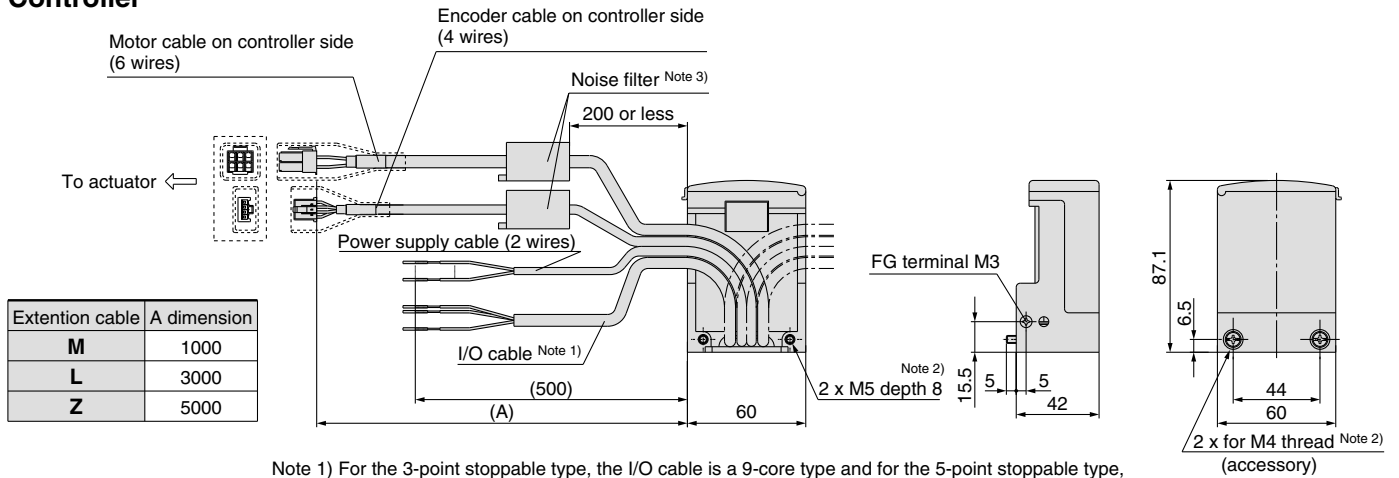

Note 1) For the 3-point stoppable type, the I/O cable is a 9-core type and for the 5-point stoppable type, a 11-core type is used.

Note 2) When mounting the remote controller, use the included M4 screw or use the M5 tap located on one side of the controller.

Note 3) When the CE compliant model is selected, a noise filter is included but not attached. The cable for the CE compliant models uses the dedicated shielding. Even if a noise filter is attached to a non CE marked product, the products cannot be changed to a CE compliant product.

L-bracket / MYE-LB (Option)

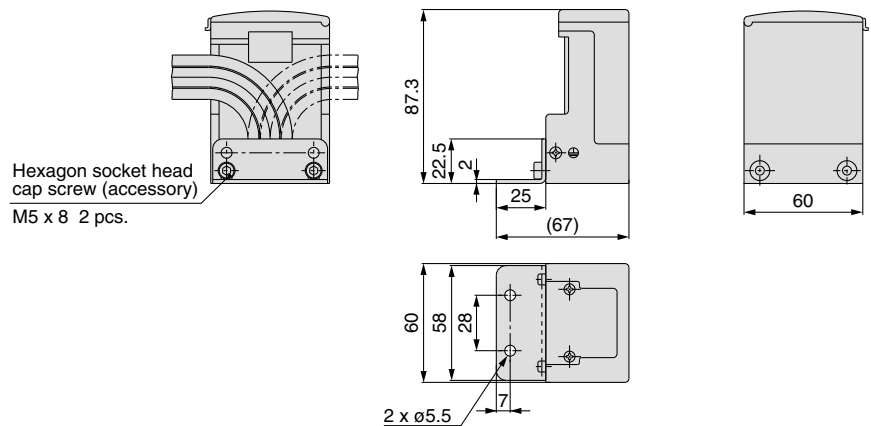

DIN rail bracket / MYE-DB (Option)

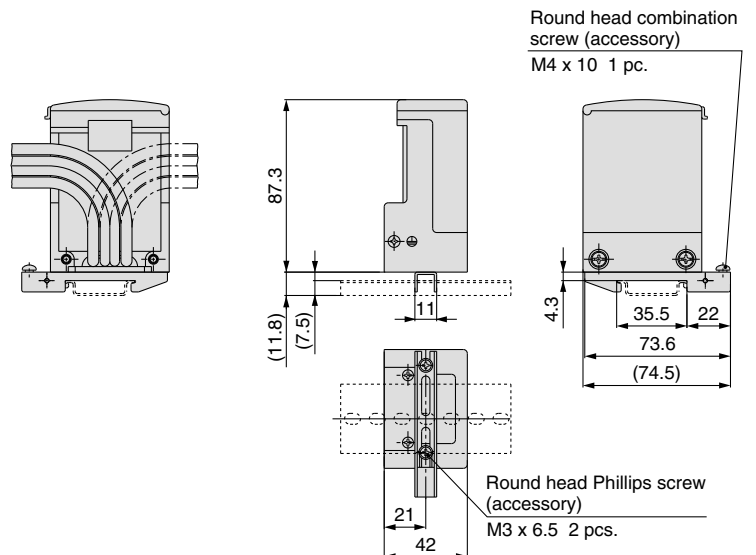

Stroke Adjusting Unit

E-MY2B-A16A

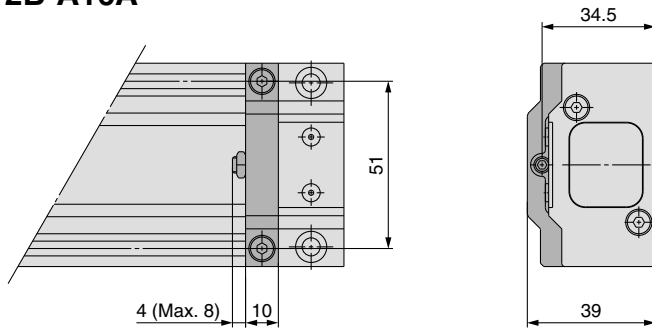

Side Support

Side support A MY-S25A

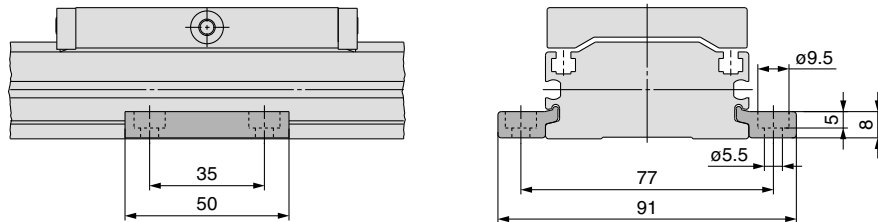

Side support B MY-S25B

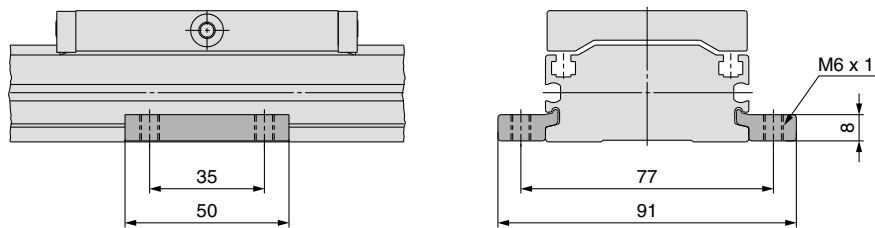

LJ1

LG1

LTF

LC1

LC7

LC8

LXF

LXP

LXS

LC6□

LZ□

LC3F2

X□

D-□

E-MY

Series E-MY2B

Floating Bracket

MYAJ25

Note) Mounting direction ① and ② are available for this model.

Application

Mounting direction ① (to minimize the installation height)

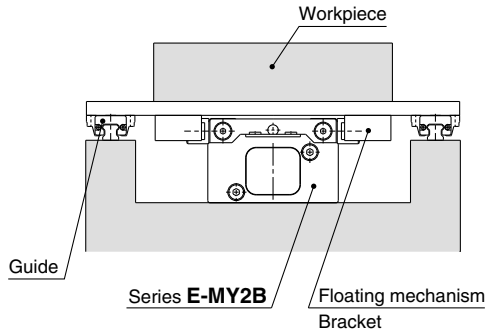

Mounting Example

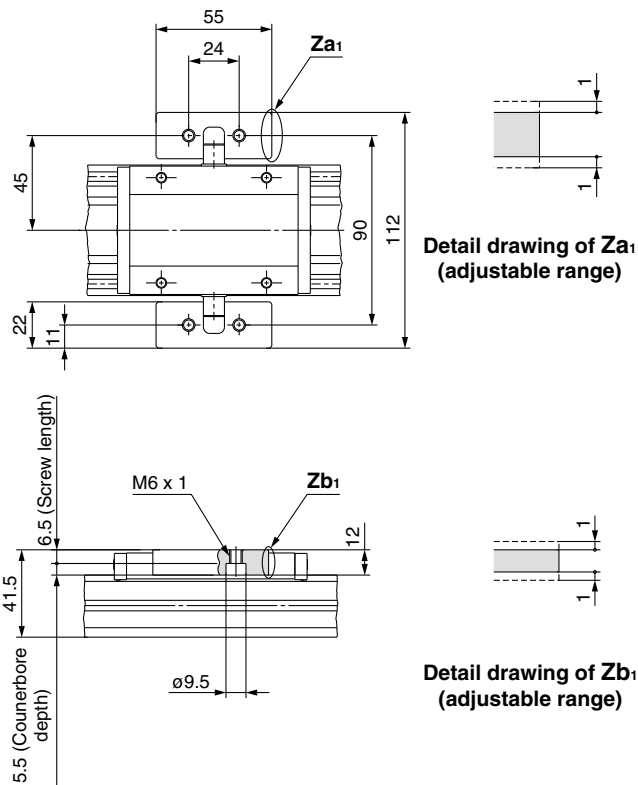

Floating Parts Dimensions

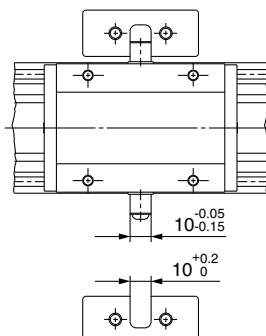

Application

Mounting direction ② (to minimize the installation width)

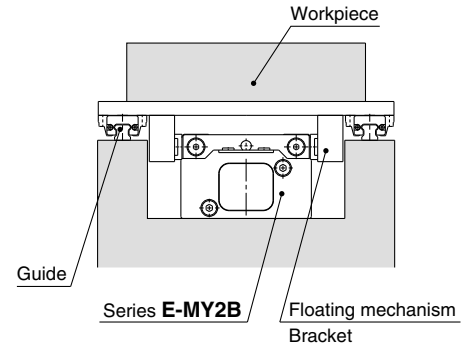

Mounting Example

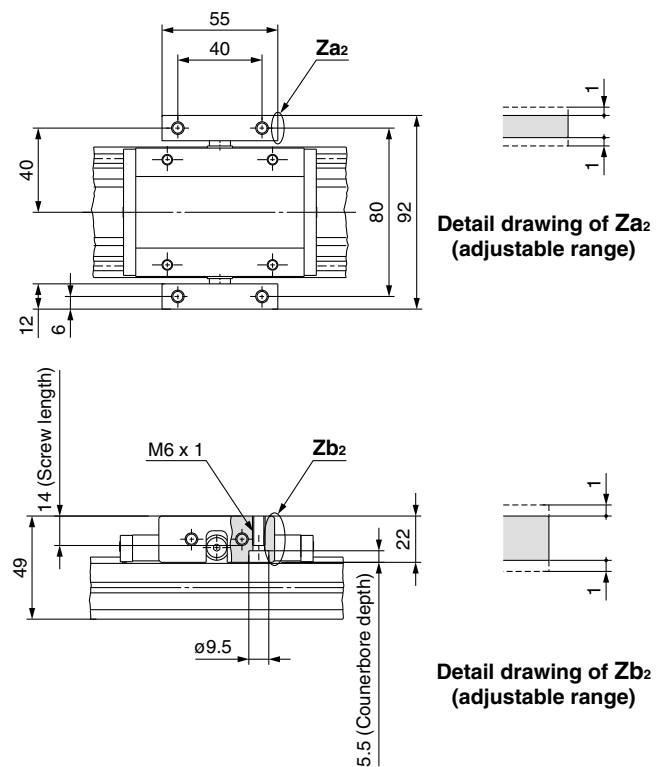

Installation of Holding Bolts

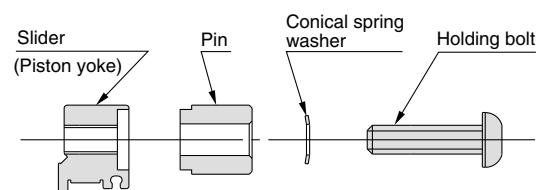

Tightening Torque for Holding Bolts

Unit: N·m

Model	Tightening torque
MYAJ25	3

Names and Functions of Individual Part

Integrated control type

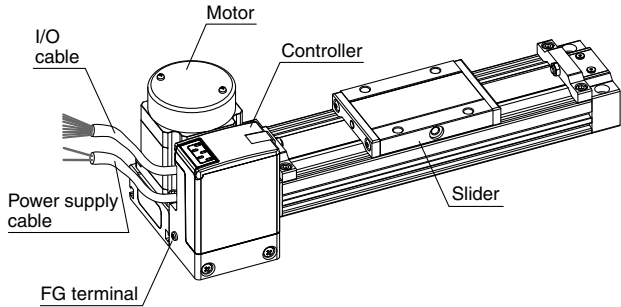

Remote control type

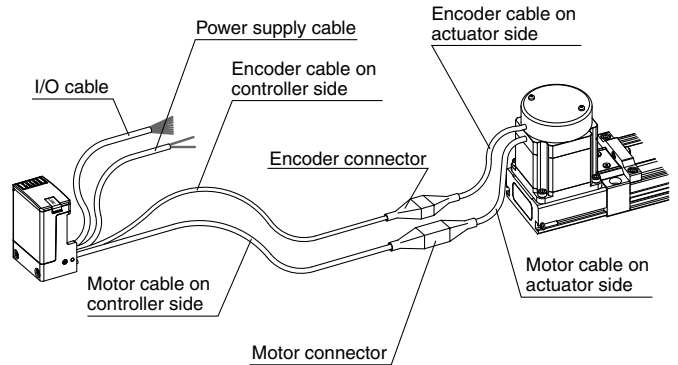

Description	Contents/Functions
Slider	Moving part within the actuator
Motor	Motor activating the actuator
Power supply cable	Power supply cable for providing power to the actuator
I/O cable	I/O cable for transmitting a positioning completion signal and driving instructions
Controller unit	The unit to control and set the actuator, and indicate its status
FG terminal	The terminal to connect the FG cable
Encoder cable on actuator side	Encoder cable for connecting the actuator with the controller
Motor cable on actuator side	Motor cable for connecting the actuator with the controller
Encoder cable on controller side	Encoder cable for separating the controller
Motor cable on controller side	Motor cable for separating the controller

Controller detail

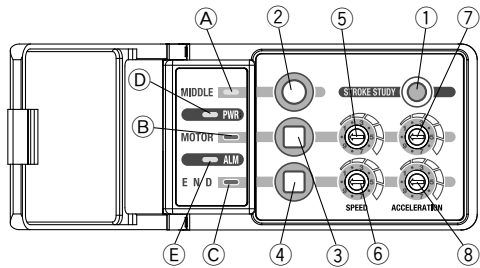

Switch

Description	Contents/Functions
1	Stroke learning switch
2 to 4	Switch to move the slider to intermediate position and set the intermediate position
5	Rotary switch to set moving speed to the motor side end
6	Rotary switch to set moving speed to the other end
7	Rotary switch to set moving acceleration to the motor side end
8	Rotary switch to set moving acceleration to the other end

Indicator Light and the Display for the Basic Functions

Symbol	Description	Power supply ON	Actuation instruction					When decelerated and completely stopped	When the alarm is activated.
			Motor side	End side	Intermediate 1	Intermediate 2 ^{*1}	Intermediate 3 ^{*1}		
A	MIDDLE Indicator light (Green)	—	—	—	○	○	○	—	
B	MOTOR Indicator light (Green)	—	○	—	—	○	—	○	*2
C	END Indicator light (Green)	—	—	○	—	—	○	○	
D	PWR Indicator light (Green)	○	○	○	○	○	○	○	○
E	ALM Indicator light (Red)	—	—	—	—	—	—	—	○

○ indicates on status, and — indicates off status.

*1 Displays for the 5-point stoppable type only.

*2 When the alarm is activated, see page 1107 for the ALM display.

LJ1

LG1

LTF

LC1

LC7

LC8

LXF

LXP

LXS

LC6□

LZ□

LC3F2

X□

D-□

E-MY

Internal Circuits and Wiring Examples

3-point Stoppable Type

Power Supply Cable 2-core AWG20 (20 wires/0.16 mm²)

Symbol	Color	Signal name	Contents
DC1 (+)	Brown	Vcc	Power supply cables for driving the actuator
DC1 (-)	Blue	GND	

I/O Cable 9-core AWG28 (7 wires/0.127 mm²)

Symbol	Color	Signal name	Contents
DC2 (+)	Brown	Vcc	Power supply cables for signal
DC2 (-)	Blue	GND	
OUT1	Pink	READY output	Signal indicating the controller is operable
OUT2	Orange	Positioning completion output 1	Signal indicating that positioning is completed
OUT3	Yellow	Positioning completion output 2	
OUT4	Green	Alarm output	Signal indicating an alarm has been generated
IN1	Purple	Actuation instruction input 1	Instruction signal to actuator
IN2	Gray	Actuation instruction input 2	
IN3	White	Emergency stop	Signal providing emergency stop instruction (The emergency stop is activated when contact is opened)

This product can be used without connecting I/O cables, however please use caution and install a power supply switch for the actuator. In case of an emergency, please turn it off.

I/O Cable Signals

Input signal

Command	Symbol	
	IN1	IN2
Motor side actuation instruction	○	—
End side actuation instruction	—	○
Intermediate actuation instruction	○	○

Output signal

Actuator status	Symbol		
	OUT1	OUT2	OUT3
Completion of motor side end positioning	○	○	—
Completion of end positioning	○	—	○
Completion of intermediate positioning	○	○	○

○ indicates on status, and — indicates off status.

NPN input/output circuit

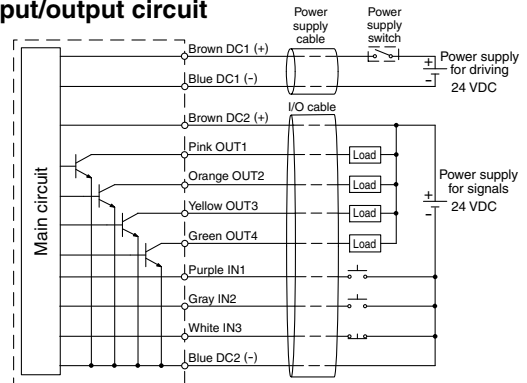

PNP input/output circuit

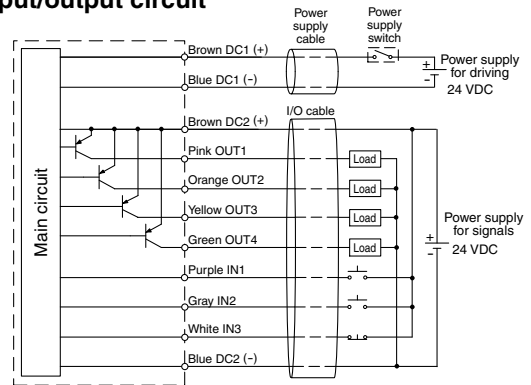

5-point Stoppable Type

Power Supply Cable 2-core AWG20 (20 wires/0.16 mm²)

Symbol	Color	Signal name	Contents
DC1 (+)	Brown	Vcc	Power supply cables for driving the actuator
DC1 (-)	Blue	GND	

I/O Cable 11-core AWG28 (7 wires/0.127 mm²)

Symbol	Color	Signal name	Contents
DC2 (+)	Brown	Vcc	Power supply cables for signal
DC2 (-)	Blue	GND	
OUT1	Pink	READY output	Signal indicating the controller is operable
OUT2	Orange	Positioning completion output 1	Signal indicating that positioning is completed
OUT3	Yellow	Positioning completion output 2	
OUT4	Red	Positioning completion output 3	
OUT5	Green	Alarm output	Signal indicating an alarm has been generated
IN1	Purple	Actuation instruction input 1	Instruction signal to actuator
IN2	Gray	Actuation instruction input 2	
IN3	Black	Actuation instruction input 3	
IN4	White	Emergency stop	Signal providing emergency stop instruction (The emergency stop is activated when contact is opened)

This product can be used without connecting I/O cables, however please use caution and install a power supply switch for the actuator. In case of an emergency, please turn it off.

I/O Cable Signals

Input signal

Command	Symbol		
	IN1	IN2	IN3
Motor side actuation instruction	○	—	—
End side actuation instruction	—	○	—
Intermediate actuation instruction 1	—	—	○
Intermediate actuation instruction 2	○	—	○
Intermediate actuation instruction 3	—	○	○
External input stop instruction	○	○	—

Output signal

Actuator status	Symbol			
	OUT1	OUT2	OUT3	OUT4
Completion of motor side end positioning	○	○	—	—
Completion of end positioning	○	—	○	—
Completion of intermediate 1 positioning	○	—	—	○
Completion of intermediate 2 positioning	○	○	—	○
Completion of intermediate 3 positioning	○	—	○	○
Completion of external input stop	○	○	○	—

○ indicates on status, and — indicates off status.

NPN input/output circuit

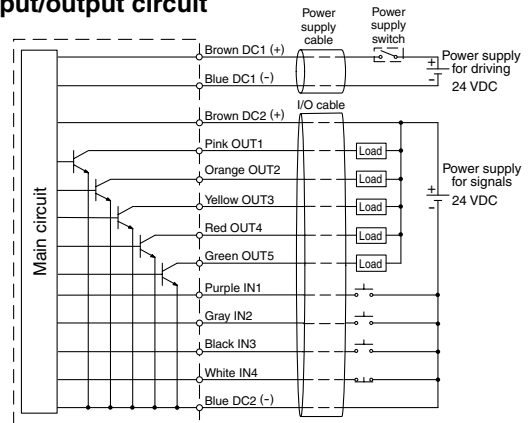

PNP input/output circuit

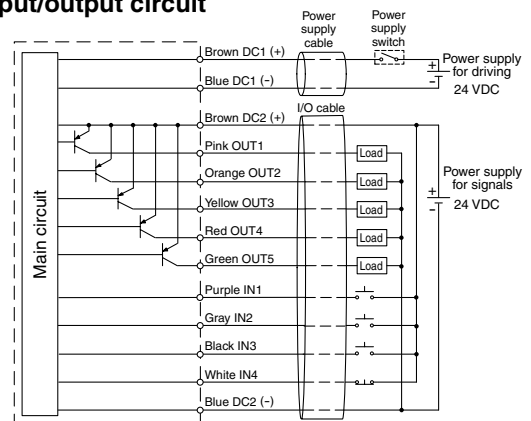

Error Display and Problem Solving

When the error indicator is displayed, refer to the following instructions.



Item	Display	Contents	Solution
Emergency stop		Either the emergency stop input is opened, or the power supply for the signal is cut-off.	Confirm the power supply signal is energized and release the emergency stop input. (Refer to the circuit diagram on page 1106.)
Abnormal external output		External output is short-circuited. * There is no external alarm output signal.	In case of common power supply, turn off the power supply and check the wiring condition of load. Restart the power supply. (Refer to the circuit diagram on page 1106.)
			In case of an independent power supply, turn off the power supply for the signals and check the wiring condition of load. Restart the power supply. (Refer to the circuit diagram on page 1106.)
Power supply abnormality		The power supply voltage is excessive or lower than the limit for operation.	Check the power supply voltage and adjust it if necessary, then press the MIDDLE button.
Drive abnormality		Maximum output is continued for a prolonged period of time.	Check the work weight and confirm that no foreign materials are attached to the actuator. After confirming, press the MIDDLE button.
Temperature abnormality		Internal temperature of the controller is high.	Lower the surrounding temperature of the actuator in use, and then press the MIDDLE button.

Item	Display	Contents	Solution
Abnormal stroke		The motor is revolving at excessive speed or stops before target is achieved.	If any foreign materials are observed, remove them and then press the MIDDLE button.
			After turning off the power supply, check to see whether the stroke adjusting unit is loose. If required, readjust the stroke and perform the stroke learning again. (Note)
Motor abnormality		The motor does not revolve properly or over current is detected.	In case of using the remote controller type, please confirm the connection of the connector part between the motor and the controller, after turning off the power supply.
			Press the MIDDLE button. In case of using the remote controller type, please confirm the connector part between the motor and the controller after cutting off the power supply.
Controller abnormality		The CPU is malfunctioning or the memory content is abnormal.	Turn off the power supply and restart it.
Error of the set value		The switch settings for speed and acceleration have been changed while in a locked condition. * There is no external alarm output signal.	Reset the settings for speed and acceleration to the set values while in a locked condition.

Note) The product is in the same condition as when the stroke learning process is completed.

- Return to the home position is not performed by the initial input
- If the error can not be corrected, turn off the power supply to stop operation, and contact your SMC sales representative.

Alarm reset

There are two types of alarm reset: alarm reset manually (a) and an alarm reset externally (b) by an external signal.

a: Alarm reset manually

In the event of an alarm, simply pushing ② will revert from the alarm state.

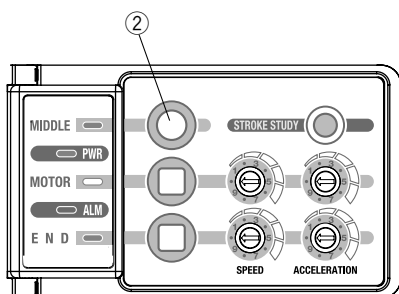

b: Alarm reset externally

In the event of an alarm, simply inputting an external emergency stop signal for 50 ms or longer will return to the state prior to the alarm. The emergency stop output will activate by releasing the input for the emergency stop.

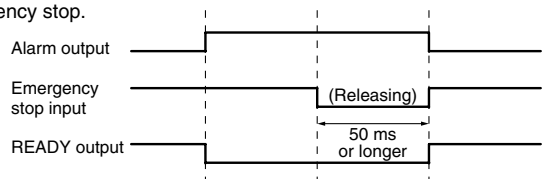

The followings are the reinstated condition.

- The slider will be free until the command for driving is applied.
- After being reverted, the next input command for driving makes it start. The initial motion after being reverted is 50 mm/s of a traveling speed.

LJ1

LG1

LTF

LC1

LC7

LC8

LXF

LXP

LXS

LC6

LZ

LC3F2

X

D-

E-MY

Series E-MY2B

Auto Switch Specifications

Auto Switch Proper Mounting Position (at Stroke End Detection)

Note) The operating range is a guide including hysteresis, but is not guaranteed. There may be large variations (as much as $\pm 30\%$) depending on the ambient environment.

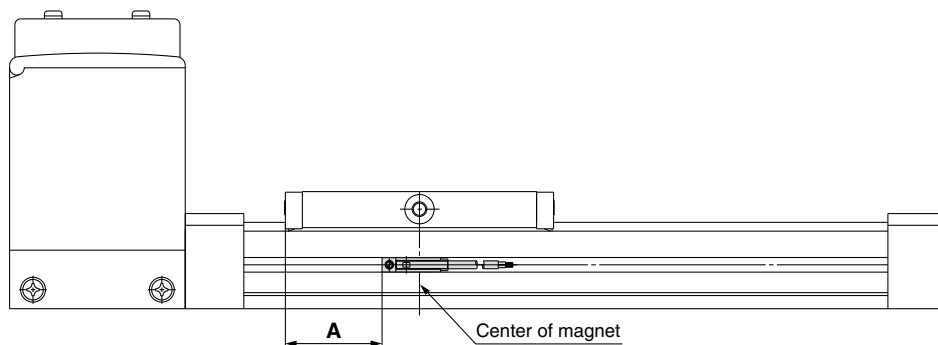

D-A9, D-A9□V

Bore size	A	Operating range
16	30	9
25	30	9

D-M9□, D-M9□V

Bore size	A	Operating range
16	34	4.5
25	34	4.5

Note) Only adjust the setting position after confirming the auto switch is properly activated.

Auto Switch Mounting

When mounting an auto switch, first hold the switch spacer with your fingers and push it into the groove. Confirm that it is aligned evenly within the groove and adjust the position if necessary. Then, insert the auto switch into the groove and slide it into the spacer.

After establishing the mounting position, use a watchmaker's flat head screwdriver to tighten the switch mounting screw which is included.

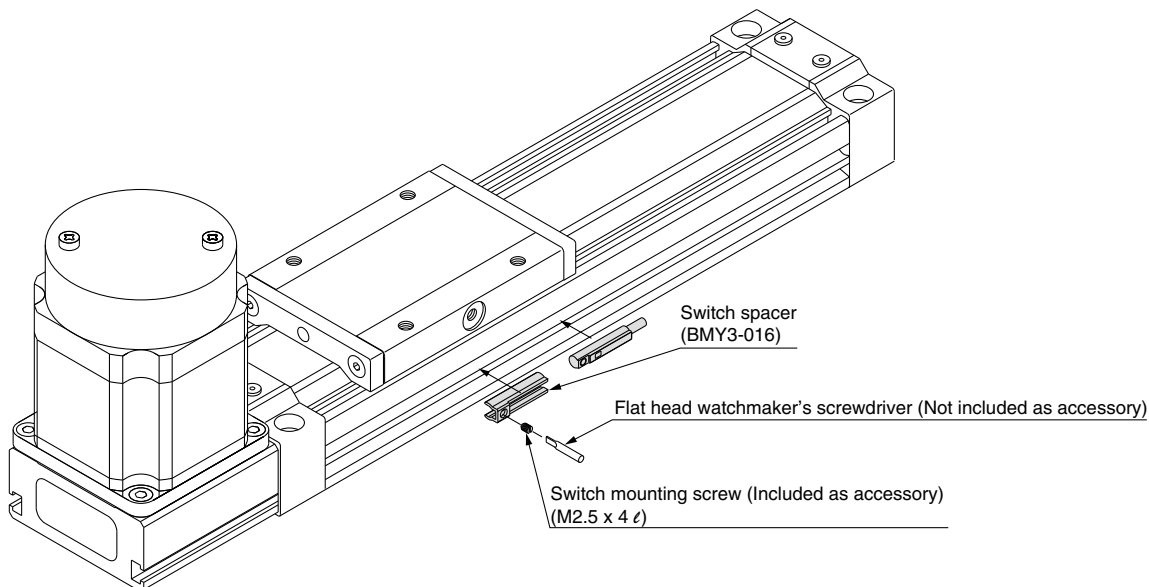

Note) When tightening an auto switch mounting screw, use a watchmaker's screwdriver with a handle of approximately 5 to 6 mm in diameter. Also, tighten with a torque of about 0.1 to 0.15 N·m. As a guide, turn about 90° past the point at which tightening can first be felt.

Switch Spacer Model

Applicable bore size (mm)	16	25
Switch spacer model	BMY3-016	



Please consult with SMC for detailed dimensions, specifications and delivery.

1 Helical Insert Thread Specifications **-X168**

The mounting threads of the slider are changed to helical insert threads. The thread size is standard size.

E-MY2B Refer to the standard model no. **-X168**

Example) E-MY2B25-300TN-M9B-X168

Others: Made to Order / For detail, please contact SMC.

● **6-point stoppable type**

Stoppable at both ends (2-point) and at intermediate strokes (4-point)

● **Max. manufacturable stroke**

Stroke exceeding 1000 mm is available.

Nominal size	E-MY2B
16	2000
25	2000

Maximum thrust is reduced depending on the stroke.

$$\text{Max. thrust} = \text{Max. payload} \times \text{Max. acceleration}$$

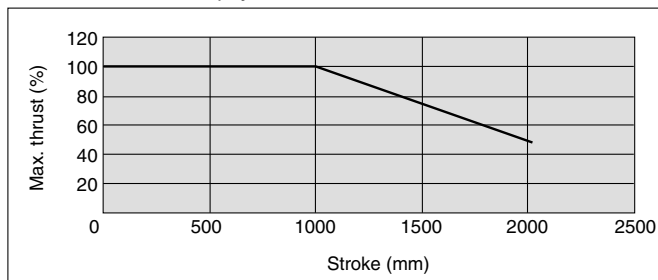

LJ1

LG1

LTF

LC1

LC7

LC8

LXF

LXP

LXS

LC6□

LZ□

LC3F2

X□

D-□

E-MY



Series E-MY2B e-Rodless Actuators Precautions 2

Be sure to read before handling.

Wiring

Warning

- 3. Perform wiring when the power is off.**
The controller section may be damaged and malfunction.
- 4. Do not wire with power lines or high voltage lines.**
Conduct wiring for controller separately from power lines or high voltage lines to avoid interference from the noise or surge from the signal lines of the power lines or high voltage lines. This may result in malfunction.
- 5. Confirm that the wiring is properly insulated.**
Be certain that there is no faulty wiring insulation (contact with other circuits, improper insulation between terminals, etc.) because the controller may be damaged due to excessively applied voltage or current flow to the controller section.
- 6. Be sure to attach a noise filter when a remote control type, CE compliant product is used.**
Using without a noise filter will be a non-CE compliant product.

Operating Environment

Warning

- 1. Do not use in a place where the product may come in contact with dust, particles, water, chemicals and oil.**
It may cause damage and malfunction.
- 2. Do not use in a place where a magnetic field is present.**
It may cause malfunction to the actuator.
- 3. Do not use the product in the presence of flammable, explosive or corrosive gas.**
It may cause fire, explosion, and corrosion.
The actuator does not have an explosion proof construction.
- 4. Do not use in an environment subjected to temperature cycle.**
If used in an environment where temperature cycling occurs, other than the usual temperature change, the internal controller may be adversely effected.
- 5. Do not use in a place that has excessive electrical surge generation, even though this product is compliant with CE marking.**
When there are units (solenoid type lifter, high frequency induction furnace, motor, etc.) which generate a large amount of surge in an area around the controller, deterioration or damage may occur to the internal circuit elements of the controller. Avoid sources of surge generation and crossed lines.
- 6. Select a product type that has built-in surge absorbing elements for a load, such as relays or solenoid valves which are employed for driving voltage generating load directly.**
- 7. Install the actuator in a place without vibration and impact.**
Vibration and impact causes damage and malfunction to the product and work, as well as prevents the work from meeting the specified parameters.

Adjustment and Operation

Warning

- 1. Do not short the loads.**
Short on the load of the controller indicates an error, but it may cause over current and damage the controller.
- 2. Do not operate or conduct any settings with wet hands.**
An electrical shock may result from wet hands.
- 3. When operating the controller, avoid making contact with the workpiece.**
Contact with the workpiece may cause injury.

Caution

- 1. Do not push the setting buttons with sharp pointed items.**
Sharp pointed items may cause setting button damage.
- 2. Do not touch the sides and lower parts of the motor and controller.**
Conduct operation after confirming that the machine is cool since it gets hot while in operation.
- 3. After the stroke is adjusted, turn on the power supply and then perform stroke learning.**
If stroke learning is not performed, the product may not operate according to the adjusted stroke and damage to any connected equipment may occur.
- 4. Do not randomly change the guide adjusting section setting.**
Readjustment of the guide is not necessary for normal operation, since it is pre-adjusted. Accordingly, do not randomly change the guide adjusting section setting.

Maintenance

Warning

- 1. Periodically perform maintenance of the product.**
Confirm that the piping and bolts are securely tightened. Unintentional malfunction of a system's components may occur as a result of an actuator malfunction.
- 2. Do not disassemble, modify (including change of printed circuit board) or repair.**
Disassembly or modification may result in injury or failure.

Caution

- 1. Confirm the range of movement of a workpiece (a slider) before connecting the driving power supply or turning on the switch.**
The movement of the work may cause an accident. When the power supply is turned on, the work is returned to home position by input IN1 or IN2 signal. (Except in the case when stroke learning is not performed ever).

LJ1

LG1

LTF

LC1

LC7

LC8

LXF

LXP

LXS

LC6□

LZ□

LC3F2

X□

D-□

E-MY