

# Series CG1

# Accessory Bracket Dimensions

## Single Knuckle Joint

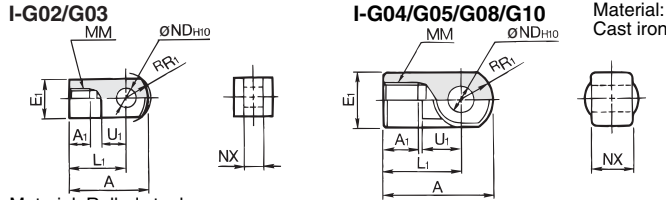

Material: Rolled steel

Part no.	Applicable bore (mm)	A	A <sub>1</sub>	E <sub>1</sub>	L <sub>1</sub>	MM	R <sub>1</sub>	U <sub>1</sub>	ND <sub>H10</sub>	NX
I-G02	20	34	8.5	□16	25	M8 x 1.25	10.3	11.5	8 <sup>+0.058</sup> <sub>0</sub>	8 <sup>-0.2</sup> <sub>-0.4</sub>
I-G03	25, 32	41	10.5	□20	30	M10 x 1.25	12.8	14	10 <sup>+0.058</sup> <sub>0</sub>	10 <sup>-0.2</sup> <sub>-0.4</sub>
I-G04	40	42	14	∅22	30	M14 x 1.5	12	14	10 <sup>+0.058</sup> <sub>0</sub>	18 <sup>-0.3</sup> <sub>-0.5</sub>
I-G05	50, 63	56	18	∅28	40	M18 x 1.5	16	20	14 <sup>+0.070</sup> <sub>0</sub>	22 <sup>-0.3</sup> <sub>-0.5</sub>
I-G08	80	71	21	∅38	50	M22 x 1.5	21	27	18 <sup>+0.070</sup> <sub>0</sub>	28 <sup>-0.3</sup> <sub>-0.5</sub>
I-G10	100	79	21	∅44	55	M26 x 1.5	24	31	22 <sup>+0.084</sup> <sub>0</sub>	32 <sup>-0.3</sup> <sub>-0.5</sub>

## Knuckle Pin

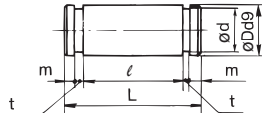

Material: Carbon steel

Part no.	Applicable bore (mm)	Dd <sub>9</sub>	L	d	ℓ	m	t	Applicable snap ring
IY-G02	20	8 <sup>-0.040</sup> <sub>-0.076</sub>	21	7.6	16.2	1.5	0.9	Type C 8 for axis
IY-G03	25, 32	10 <sup>-0.040</sup> <sub>-0.076</sub>	25.6	9.6	20.2	1.55	1.15	Type C 10 for axis
IY-G04	40	10 <sup>-0.040</sup> <sub>-0.076</sub>	41.6	9.6	36.2	1.55	1.15	Type C 10 for axis
IY-G05	50, 63	14 <sup>-0.050</sup> <sub>-0.093</sub>	50.6	13.4	44.2	2.05	1.15	Type C 14 for axis
IY-G08	80	18 <sup>-0.050</sup> <sub>-0.093</sub>	64	17	56.2	2.55	1.35	Type C 18 for axis
IY-G10	100	22 <sup>-0.065</sup> <sub>-0.117</sub>	72	21	64.2	2.55	1.35	Type C 22 for axis

## Clevis Pin

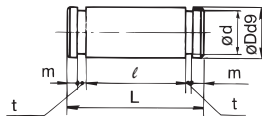

Material: Carbon steel

Part no.	Applicable bore (mm)	Dd <sub>9</sub>	L	d	ℓ	m	t	Applicable snap ring
CD-G02	20	8 <sup>-0.040</sup> <sub>-0.076</sub>	43.4	7.6	38.6	1.5	0.9	Type C 8 for axis
CD-G25	25	10 <sup>-0.040</sup> <sub>-0.076</sub>	48	9.6	42.6	1.55	1.15	Type C 10 for axis
CD-G03	32	12 <sup>-0.050</sup> <sub>-0.093</sub>	59.4	11.5	54	1.55	1.15	Type C 12 for axis
CD-G04	40	14 <sup>-0.050</sup> <sub>-0.093</sub>	71.4	13.4	65	2.05	1.15	Type C 14 for axis
CD-G05	50	16 <sup>-0.050</sup> <sub>-0.093</sub>	86	15.2	79.6	2.05	1.15	Type C 16 for axis
CD-G06	63	18 <sup>-0.050</sup> <sub>-0.093</sub>	105.4	17	97.8	2.45	1.35	Type C 18 for axis

\* Clevis pin and knuckle pin are common for bore size ∅80 and ∅100.

## Rod End Nut

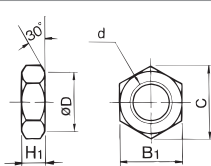

Material: Rolled steel

Part no.	Applicable bore (mm)	d	H <sub>1</sub>	B <sub>1</sub>	C	D
NT-02	20	M8 x 1.25	5	13	(15.0)	12.5
NT-03	25, 32	M10 x 1.25	6	17	(19.6)	16.5
NT-G04	40	M14 x 1.5	8	19	(21.9)	18
NT-05	50, 63	M18 x 1.5	11	27	(31.2)	26
NT-08	80	M22 x 1.5	13	32	(37.0)	31
NT-10	100	M26 x 1.5	16	41	(47.3)	39

## Double Knuckle Joint

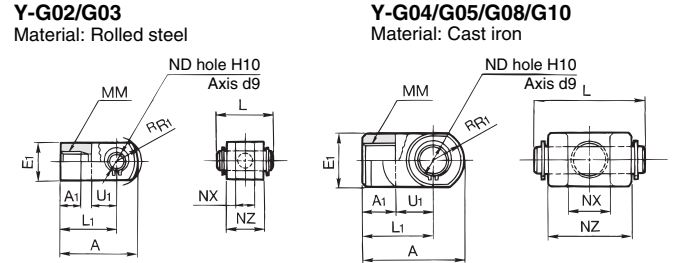

Part no.	Applicable bore (mm)	A	A <sub>1</sub>	E <sub>1</sub>	L <sub>1</sub>	MM	R <sub>1</sub>	U <sub>1</sub>	ND	NX	NZ	L	Applicable pin part no.
Y-G02	20	34	8.5	□16	25	M8 x 1.25	10.3	11.5	8	8 <sup>-0.4</sup> <sub>0</sub>	16	21	IY-G02
Y-G03	25, 32	41	10.5	□20	30	M10 x 1.25	12.8	14	10	10 <sup>-0.2</sup> <sub>-0.4</sub>	20	25.6	IY-G03
Y-G04	40	42	16	∅22	30	M14 x 1.5	12	14	10	18 <sup>-0.5</sup> <sub>-0.3</sub>	36	41.6	IY-G04
Y-G05	50, 63	56	20	∅28	40	M18 x 1.5	16	20	14	22 <sup>-0.5</sup> <sub>-0.3</sub>	44	50.6	IY-G05
Y-G08	80	71	23	∅38	50	M22 x 1.5	21	27	18	28 <sup>-0.5</sup> <sub>-0.3</sub>	56	64	IY-G08
Y-G10	100	79	24	∅44	55	M26 x 1.5	24	31	22	32 <sup>-0.5</sup> <sub>-0.3</sub>	64	72	IY-G10

\* Knuckle pin and set ring are shipped together.

## Pivot Bracket (Order separately)

### ∅20 to ∅63

Material: Rolled steel

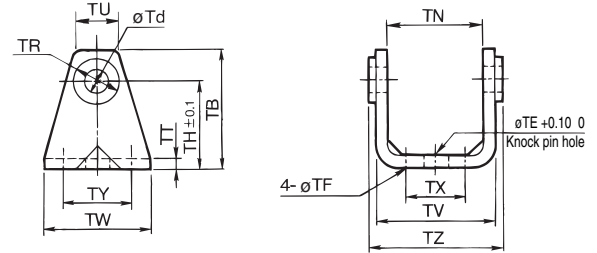

### ∅80, ∅100

Material: Cast iron

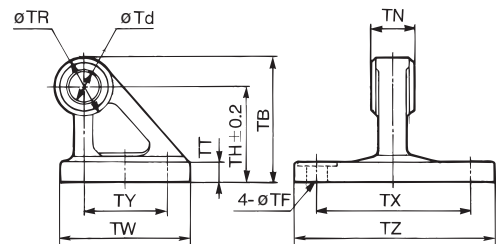

Part no.	Applicable bore (mm)	TB	Td	TE	TF	TH	TN	TR	TT
CG-020-24A	20	36	8	10	5.5	25	(29.3)	13	3.2
CG-025-24A	25	43	10	10	5.5	30	(33.1)	15	3.2
CG-032-24A	32	50	12	10	6.6	35	(40.4)	17	4.5
CG-040-24A	40	58	14	10	6.6	40	(49.2)	21	4.5
CG-050-24A	50	70	16	20	9	50	(60.4)	24	6
CG-063-24A	63	82	18	20	11	60	(74.6)	26	8
CG-080-24A	80	73	18	—	11	55	28 <sup>0.1</sup> <sub>-0.3</sub>	36	11
CG-100-24A	100	90	22	—	13.5	65	32 <sup>0.1</sup> <sub>-0.3</sub>	50	12

Part no.	Applicable bore (mm)	TU	TV	TW	TX	TY	TZ	Applicable pin O.D.
CG-020-24A	20	(18.1)	(35.8)	42	16	28	38.3	8d <sub>9</sub> <sup>-0.040</sup> <sub>-0.076</sub>
CG-025-24A	25	(20.7)	(39.8)	42	20	28	42.1	10d <sub>9</sub> <sup>-0.040</sup> <sub>-0.076</sub>
CG-032-24A	32	(23.6)	(49.4)	48	22	28	53.8	12d <sub>9</sub> <sup>-0.050</sup> <sub>-0.093</sub>
CG-040-24A	40	(27.3)	(58.4)	56	30	30	64.6	14d <sub>9</sub> <sup>-0.050</sup> <sub>-0.093</sub>
CG-050-24A	50	(29.7)	(72.4)	64	36	36	79.2	16d <sub>9</sub> <sup>-0.050</sup> <sub>-0.093</sub>
CG-063-24A	63	(34.3)	(90.4)	74	46	46	97.2	18d <sub>9</sub> <sup>-0.050</sup> <sub>-0.093</sub>
CG-080-24A	80	—	—	72	85	45	110	18d <sub>9</sub> <sup>-0.050</sup> <sub>-0.093</sub>
CG-100-24A	100	—	—	93	100	60	130	22d <sub>9</sub> <sup>-0.065</sup> <sub>-0.117</sub>

## Accessory Bracket Dimensions

### Single Knuckle Joint

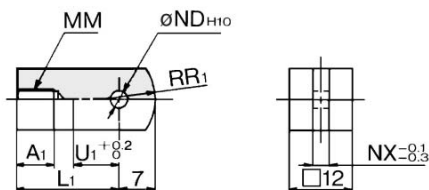

Material: Rolled steel

Part no.	Applicable bore (mm)	A <sub>1</sub>	L <sub>1</sub>	MM	ND <sup>H10</sup>	NX	R <sub>1</sub>	U <sub>1</sub>
I-J010B	10	8	21	M4 x 0.7	3.3 <sup>+0.048</sup> <sub>-0.060</sub>	3.1	8	9
I-J016B	16	8	25	M5 x 0.8	5.3 <sup>+0.048</sup> <sub>-0.060</sub>	6.4	12	14

### Double Knuckle Joint

\* Knuckle pin and set ring are shipped together.

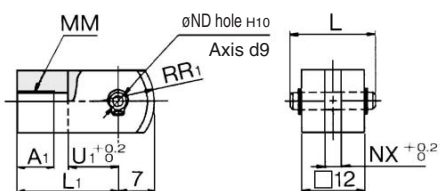

Material: Rolled steel

Part no.	Applicable bore (mm)	A <sub>1</sub>	L	L <sub>1</sub>	MM
Y-J010B	10	8	15.2	21	M4 x 0.7
Y-J016B	16	11	16.6	21	M5 x 0.8

Part no.	ND <sub>d9</sub>	ND <sup>H10</sup>	NX	R <sub>1</sub>	U <sub>1</sub>
Y-J010B	3.3 <sup>-0.030</sup> <sub>-0.060</sub>	3.3 <sup>+0.048</sup> <sub>0</sub>	3.2	8	10
Y-J016B	5.3 <sup>-0.030</sup> <sub>-0.060</sub>	5.3 <sup>+0.048</sup> <sub>0</sub>	6.5	12	10

### T-bracket

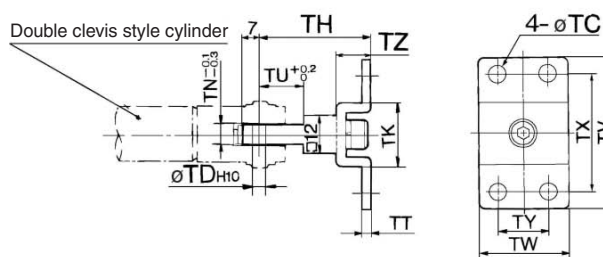

Part no.	Applicable bore (mm)	TC	TD <sup>H10</sup>	TH	TK	TN	TT	TU	TV	TW	TX	TY	TZ
CJ-T010B	10	4.5	3.3 <sup>+0.048</sup> <sub>-0.060</sub>	29	18	3.1	2	9	40	22	32	12	8
CJ-T016B	16	5.5	5 <sup>+0.048</sup> <sub>-0.060</sub>	35	20	6.4	2.3	14	48	28	38	16	10

### Clevis Pin

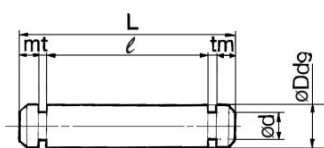

Material: Stainless steel

Part no.	Applicable bore (mm)	Dd <sub>9</sub>	d	L	ℓ	m	t	Applicable snap ring
CD-J010	10	3.3 <sup>-0.030</sup> <sub>-0.060</sub>	3	15.2	12.2	1.2	0.3	Type C 3.2
CD-Z015	16	5.3 <sup>-0.030</sup> <sub>-0.060</sub>	4.8	22.7	18.3	1.5	0.7	Type C 5
CD-JA010*	10	3.3 <sup>-0.030</sup> <sub>-0.060</sub>	3	18.2	15.2	1.2	0.3	Type C 3.2

\* For ø10 double clevis style, with air cushion and built-in speed controller.

### Mounting Nut

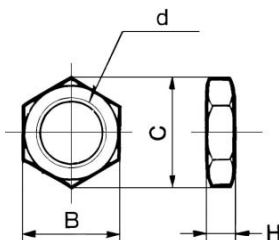

Material: Brass

Part no.	Applicable bore (mm)	B	C	d	H
SNJ-006B	6	8	9.2	M6 x 1.0	4
SNJ-010B	10	11	12.7	M8 x 1.0	4
SNJ-016B	16	14	16.2	M10 x 1.0	4
SNKJ-016B*	16	17	19.6	M12 x 1.0	4

\* For ø16 non-rotating type. (Use SNJ-016B for ø10 non-rotating type.)

### Knuckle Pin

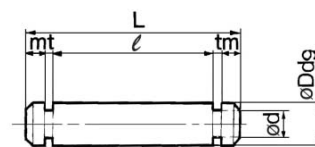

Material: Stainless steel

Part no.	Applicable bore (mm)	Dd <sub>9</sub>	d	L	ℓ	m	t	Applicable snap ring
CD-J010	10	3.3 <sup>-0.030</sup> <sub>-0.060</sub>	3	15.2	12.2	1.2	0.3	Type C 3.2
IY-J015	16	5.3 <sup>-0.030</sup> <sub>-0.060</sub>	4.8	16.6	12.2	1.5	0.7	Type C 5

\* For size ø10, clevis pin is diverted.

### Rod End Nut

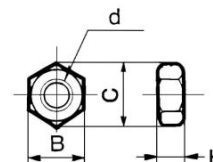

Material: Iron

Part no.	Applicable bore (mm)	B	C	d	H
NTJ-006A	6	5.5	6.4	M3 x 0.5	2.4
NTJ-010A	10	7	8.1	M4 x 0.7	3.2
NTJ-015A	16	8	9.2	M5 x 0.8	4

### Rod End Cap

Flat type/CJ-CF□□□

Round type/CJ-CR□□□

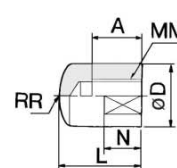
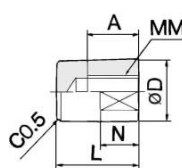

Material: Polyacetal

Part no.		Applicable bore (mm)	A	D	L	MM	N	R	W
Flat type	Round type								
CJ-CF006	CJ-CR006	6	6	8	11	M3 x 0.5	5	8	6
CJ-CF010	CJ-CR010	10	8	10	13	M4 x 0.7	6	10	8
CJ-CF016	CJ-CR016	16	10	12	15	M5 x 0.8	7	12	10

- CJ1
- CJP
- CJ2**
- CM2
- CG1
- MB
- MB1
- CA2
- CS1
- C76
- C85
- C95
- CP95
- NCM
- NCA
- D-
- X
- 20-
- Data

# Series MB

## Trunnion/Double Clevis Pivot Bracket

### Part No.

Cylinder model	MB□32	MB□40	MB□50	MB□63	MB□80	MB□100	MB□125
Description	MB-S03	MB-S04	MB-S04	MB-S06	MB-S06	MB-S10	MB-S12
Trunnion pivot bracket Note 1)	MB-S03	MB-S04	MB-S04	MB-S06	MB-S06	MB-S10	MB-S12
Double clevis pivot bracket	MB-B03	MB-B05	MB-B05	MB-B08	MB-B08	MB-B12	MB-B12

Note 1) When ordering a trunnion pivot bracket, order 2 pcs. for 1 cylinder.

### Trunnion pivot bracket

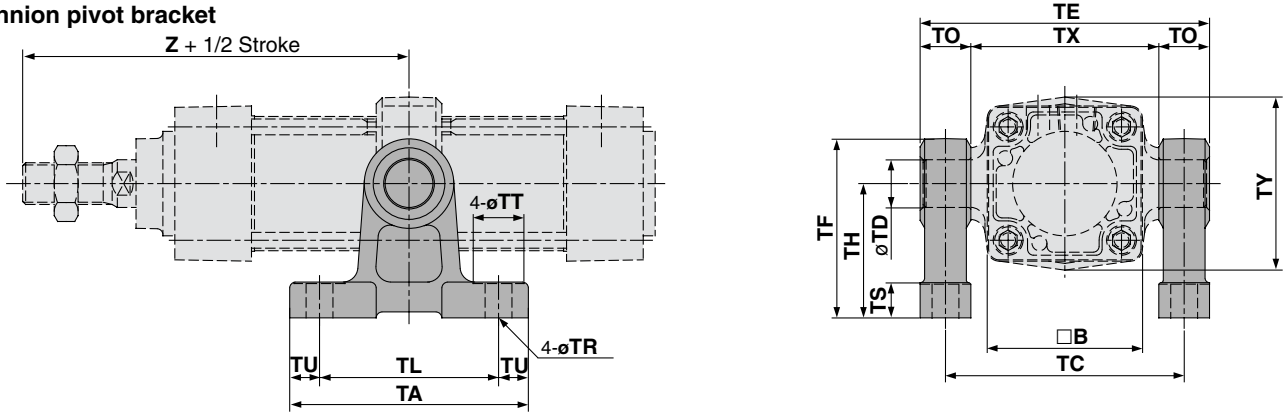

(mm)

### Without Air Cushion

Part no.	Bore size (mm)	B	TA	TL	TU	TC	TX	TE	TO	TR	TT	TS	TH	TF	Z**	TDH10
MB-S03	32	46	62	45	8.5	62	50	74	12	7	13	10	35	47	89	12 <sup>+0.070</sup> <sub>0</sub>
MB-S04	40	52	80	60	10	80	63	97	17	9	17	12	45	60	93	16 <sup>+0.070</sup> <sub>0</sub>
	50	65	80	60	10	92	75	109	17	9	17	12	45	60	105	16 <sup>+0.070</sup> <sub>0</sub>
MB-S06	63	75	100	70	15	110	90	130	20	11	22	14	60	80	105	20 <sup>+0.084</sup> <sub>0</sub>
	80	95	100	70	15	130	110	150	20	11	22	14	60	80	129	20 <sup>+0.084</sup> <sub>0</sub>
MB-S10	100	114	120	90	15	158	132	184	26	13.5	24	17	75	100	129	25 <sup>+0.084</sup> <sub>0</sub>
MB-S12	125	136	142	105	18.5	186	160	212	26	13.5	24	25	85	115	157	25 <sup>+0.084</sup> <sub>0</sub>

Bore size (mm)	Z
32	92
40	96
50	109
63	109
80	134
100	134
125	163

### Double clevis pivot bracket

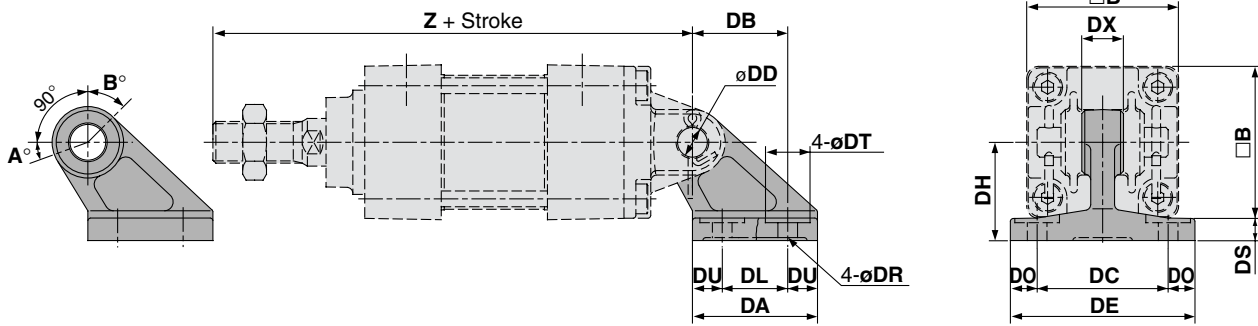

(mm)

### Without Air Cushion

Part no.	Bore size (mm)	B	DA	DB	DL	DU	DC	DX	DE	DO	DR	DT	DS	DH	Z*	DDH10
MB-B03	32	46	42	32	22	10	44	14	62	9	6.6	15	7	33	154	10 <sup>+0.058</sup> <sub>0</sub>
	40	52	42	32	22	10	44	14	62	9	6.6	15	7	33	158	10 <sup>+0.058</sup> <sub>0</sub>
MB-B05	50	65	53	43	30	11.5	60	20	81	10.5	9	18	8	45	182	14 <sup>+0.070</sup> <sub>0</sub>
	63	75	53	43	30	11.5	60	20	81	10.5	9	18	8	45	182	14 <sup>+0.070</sup> <sub>0</sub>
MB-B08	80	95	73	64	45	14	86	30	111	12.5	11	22	10	65	228	22 <sup>+0.084</sup> <sub>0</sub>
	100	114	73	64	45	14	86	30	111	12.5	11	22	10	65	228	22 <sup>+0.084</sup> <sub>0</sub>
MB-B12	125	136	90	78	60	15	110	32	136	13	13.5	24	14	75	267	25 <sup>+0.084</sup> <sub>0</sub>

Bore size (mm)	Z
32	160
40	164
50	190
63	190
80	238
100	238
125	279

### Rotating Angle

Bore size (mm)	A°	B°	A° + B° + 90°
32, 40	25°	45°	160°
50, 63	40°	60°	190°
80, 100	30°	55°	175°
125	30°	50°	170°

#### \* Mounting plate

Model without air cushion is designed to include rubber bumpers. The overall length is longer than the cylinder with air cushion as follows because the bumpers are attached to the both sides of the piston; ø32, ø40: +6 mm, ø50, ø63: +8 mm, ø80, ø100: +10 mm, ø125: +12 mm

#### \*\* Trunnion pivot bracket

Model without air cushion is designed to include rubber bumpers. The overall length is longer than the cylinder with air cushion as follows because the bumpers are attached to the both sides of the piston; ø32, ø40: +3 mm, ø50, ø63: +4 mm, ø80, ø100: +5 mm, ø125: +6 mm