





Valve Mounted Cylinder

CV□ Series

ø10, ø16, ø20, ø25, ø32, ø40, ø50, ø63, ø80, ø100

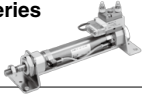
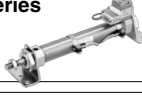
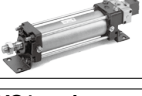
Series Variations

Series	Action	Standard variations					Bore size (mm)	Page
		Built-in magnet	With air cushion	Built-in One-touch fitting	With auto switch	With strong scraper		
CVJ5 series 	Double acting	●			●		10 16	P.1154
CVJ3 series 	Single acting (Spring return) (Spring extend)	●			●		10 16	P.1164
CVM5/CVM5K series 	Double acting	Standard	●		●	●	20 25 32 40	P.1175 P.1185
		Non-rotating rod	●		●	●		
CVM3/CVM3K series 	Single acting (Spring return) (Spring extend)	Standard	●		●	●	20 25 32 40	P.1194 P.1207
		Non-rotating rod	●		●	●		
CV3/CV3K series 	Double acting	Standard	●	●	●	●	40 · 50 63 · 80 100	P.1216 P.1228
		Non-rotating rod	●	●	●	●		
CVS1 series 	Double acting	●	●		●	●	40 · 50 63 · 80 100	P.1238

Valve Mounted Cylinder Double Acting, Single Rod CVJ5 Series

∅10, ∅16

How to Order

Mounting type

B	Basic type
L	Axial foot type
F	Rod side flange type

Bore size

∅10	15, 30, 45, 60
∅16	15, 30, 45, 60

Stroke (mm)

10	10 mm
16	16 mm

Electrical entry

G	Grommet
L	L plug connector
M	M plug connector

Light/Surge voltage suppressor

Nil	Without light/surge voltage suppressor
S	With surge voltage suppressor
Z	With light/surge voltage suppressor
R	With surge voltage suppressor (No polarity)
U	With light/surge voltage suppressor (No polarity)

* Type "R", "U": DC only
* In the case of AC, since the rectifier prevents the production of surge voltage, there is no type "S".

CVJ5 L 16 - 60 - 5 L -

With auto switch CDVJ5 L 16 - 60 - 5 L - M9BW - C -

With auto switch (Built-in magnet)

Nil	Rod extended when energized
B	Rod retracted when energized

Solenoid valve code

DC specifications		AC specifications (50/60 Hz)	
S	24 VDC	1	100 VAC
6	12 VDC	2	200 VAC
V	6 VDC	3	110 VAC (115 VAC)
S	5 VDC	4	220 VAC (230 VAC)
R	3 VDC		

Built-in Magnet Cylinder Model

Suffix the symbol "A" (Rail mounting type) or "B" (Band mounting type) to the end of the w/ auto switch cylinder part number.

Example: Rail mounting type CDVJ5B16-60-A
Band mounting type CDVJ5B10-45-B

Auto switch

Magnet installed even without auto switch

Symbol	Auto switch mounting
A	Rail mounting type
B	Band mounting type

Auto switch mounting bracket ^(Note)

Note) This symbol is indicated when the D-A9□ or M9□ type auto switch is specified. This mounting bracket does not apply to other auto switches (D-C7□ and H7□, etc.) (Nil)

Number of auto switches

Nil	2 pcs.
S	1 pc.
n	"n" pcs.

Made to Order
Refer to page 1155 for details.

Applicable Auto Switches/Refer to pages 1341 to 1435 for further information on auto switches.

Type	Special function	Electrical entry	Indicator light	Wiring (Output)	Load voltage		Auto switch model				Lead wire length (m)					Pre-wired connector	Applicable load
					DC	AC	Band mounting		Rail mounting		0.5 (Nil)	1 (M)	3 (L)	5 (Z)	None (N)		
							Perpendicular	In-line	Perpendicular	In-line							
Solid state auto switch	Diagnostic indication (2-color indicator)	Grommet	Yes	3-wire (NPN)	24 V	5 V, 12 V	M9NV	M9N	—	—	●	●	○	○	○	IC circuit	
							—	F7NV	F79	●	●	○	○	○			
				M9PV			M9P	—	—	●	●	○	○	○			
		—		F7PV			F7P	●	●	○	○	○	○				
		M9BV		M9B			—	—	●	●	○	○	○				
		—		F7BV			J79	●	●	○	○	○	○				
	Water resistant (2-color indicator)	Grommet	Yes	3-wire (NPN)	24 V	5 V, 12 V	M9NWV	M9NW	—	—	●	●	○	○	○	IC circuit	
							—	F7NWV	F79W	●	●	○	○	○			
				M9PWV			M9PW	—	—	●	●	○	○	○			
		—		F7PW			—	—	●	●	○	○	○				
		M9BWW		M9BW			—	—	●	●	○	○	○				
		—		F7BWW			J79W	●	●	○	○	○	○				
Reed auto switch	Diagnostic indication (2-color indicator)	Grommet	Yes	3-wire (NPN equivalent)	24 V	5 V, 12 V	A96V	A96	—	—	●	●	○	○	○	IC circuit	
							—	A76H	—	—	●	●	○	○	○		
				—			A72H	—	—	●	●	○	○	○			
		—		A93V			A93	A73	A73H	●	●	○	○	○			
		—		A90V			A90	A80	A80H	●	●	○	○	○			
		—		C73C			A73C	—	—	●	●	○	○	○			
	Diagnostic indication (2-color indicator)	Grommet	Yes	2-wire	24 V	12 V	—	—	—	—	●	●	○	○	○	IC circuit	
							—	—	—	—	●	●	○	○	○		
				—			—	—	—	●	●	○	○	○			
		—		—			—	—	●	●	○	○	○				
		—		—			—	—	●	●	○	○	○				
		—		—			—	—	●	●	○	○	○				

* Lead wire length symbols: 0.5 m..... Nil (Example) M9NW
1 m..... M (Example) M9NWM
3 m..... L (Example) M9NWL
5 m..... Z (Example) M9NWZ

* Auto switches marked with "○" are produced upon receipt of order.

* D-A9□/M9□/A7□/A8□/F7□/J7□ auto switches are shipped together (not assembled). (For D-A9□/M9□, only auto switch mounting brackets are assembled before shipped.)

* D-C7□/C8□/H7□ auto switches are assembled at the time of shipment.

* Order auto switch mounting brackets separately when D-A9□(V)/M9□(V)/M9□W(V)/M9□A(V) are mounted on ∅10 and ∅16 of the rail mounting type. Refer to page 1163 for details.

*1 Water resistant type auto switches can be mounted on the above models, but in such case SMC cannot guarantee water resistance.

*2 The load voltage used is 24 VDC.

* Since there are other applicable auto switches than listed, refer to page 1163 for details.

* For details about auto switches with pre-wired connector, refer to pages 1410 and 1411.

Valve Mounted Cylinder **CVJ5 Series**

Operation type can be changed to rod extended when energized or rod retracted when energized.

An auto switch cylinder with the switch installed can also be manufactured.

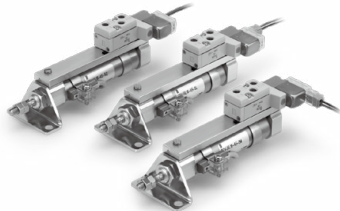

Symbol

Double acting/Single rod, Rubber bumper

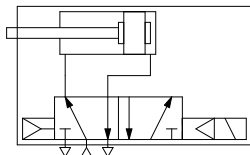

Specifications

Bore size (mm)	ø10	ø16
Action	Double acting, Single rod	
Fluid	Air	
Proof pressure	1.05 MPa	
Maximum operating pressure	0.7 MPa	
Minimum operating pressure	0.15 MPa	
Ambient and fluid temperature	-10 to 50°C (No freezing)	
Cushion	Rubber bumper	
Lubrication	Not required (Non-lube)	
Stroke length tolerance	+1.0 0	
Port size	M5 x 0.8	
Mounting	Basic type, Axial foot type, Rod side flange type	
Piston speed	50 to 750 mm/s	50 to 150 mm/s
Allowable kinetic energy	0.035J	0.090J

Solenoid Valve Specifications

Applicable solenoid valve model		SYJ3190	
Electrical entry		Grommet (G), L plug connector (L), M plug connector (M)	
Coil rated voltage (V)	DC	24, 12, 6, 5, 3	
	AC 50/60 Hz	100, 110, 200, 220	
Effective area of valve (Cv factor)		1.8 mm ² (0.1)	
Allowable voltage		±10% of the rated voltage*	
Power consumption (W)	DC	Standard	0.35 (With indicator light: 0.4)
	AC	100 V	0.78 (With indicator light: 0.81)
110 V		0.86 (With indicator light: 0.89)	
[115 V]		[0.94 (With indicator light: 0.97)]	
200 V		1.18 (With indicator light: 1.22)	
220 V		1.30 (With indicator light: 1.34)	
[230 V]	[1.42 (With indicator light: 1.46)]		
Surge voltage suppressor		Diode (Varistor for the non-polar type)	
Indicator light		LED	

* 110 VAC and 115 VAC types and 220 VAC and 230 VAC types are common respectively.

* For 115 VAC and 230 VAC, allowable voltage fluctuation is -15 to +5 % of the rated voltage.

* For S and Z, the voltage will drop due to the internal circuit. Allowable voltage fluctuation must be in the range below.

Types S, Z 24 VDC: -7 to 10 %, 12 VDC: -4 to 10 %



Made to Order Specifications

[Click here for details](#)

Symbol	Specifications
-XA□	Change of rod end shape

Standard Stroke

Bore size (mm)	Standard stroke (mm)
10	15, 30, 45, 60
16	15, 30, 45, 60

CVJ5 Series

Mounting Type and Accessory For details, refer to page 1159.

Mounting		Basic type	Axial foot type	Rod side flange type
Standard equipment	Mounting nut	●	●	●
	Rod end nut	●	●	●
Option	Single knuckle joint	○	○	○
	Double knuckle joint (With pin)*	○	○	○

* Knuckle pin and retaining ring are shipped together. ●...Supplied with the product. ○...Please order separately.

Weight (g)

Bore size (mm)		10	16
Basic weight*		71	99
Additional weight per each 15 mm of stroke		6.5	9.5
Mounting bracket weight	Axial foot type	7	19
	Rod side flange type	5	13

* Mounting nut and rod end nut are included in the basic weight.

Calculation: (Example) **CVJ5L10-45-1G**

- Basic weight.....71 (g) (ø10)
 - Additional weight6.5/15 stroke
 - Cylinder stroke45 stroke
 - Weight of bracket7 (g) (Axial foot type)
- 71 + 6.5/15 x 45 + 7 = 97.5 g

Mounting Bracket Part No.

Mounting bracket	Bore size (mm)	
	10	16
Foot	CJ-L010C	CJ-L016C
Flange	CJ-F010C	CJ-F016C

Accessory (Option)

Refer to page 1159 for part numbers and dimensions of the single knuckle joint, double knuckle joint, knuckle pin, mounting nut, and rod end nut.

Changing between Rod Extended when Energized and Rod Retracted when Energized

<Step>

This procedure is for changing the rod extended when energized to the rod retracted when energized.

- Using a screwdriver, loosen the two small round head screws, and remove the plate and the solenoid valve. At this time, instead of removing the plate and the solenoid valve separately, remove them together, with the round head screws remaining inserted.

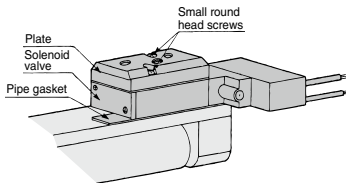

- Turn the pipe gasket at 180° and mount, showing the letter "B".

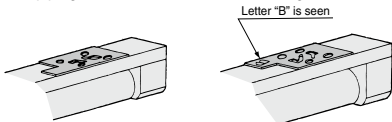

- Install the solenoid valve and the plate, and tighten the small round head screws, with a screw driver. After tightening, press the manual button on the solenoid valve, check for any air leaks, and verify the operating conditions. When the cylinder is viewed from above, the position of the gasket is as shown in the figure below.

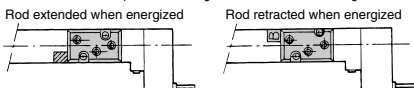

Manual Operation

Manual operation is possible by pushing the manual button indicated with the arrow.

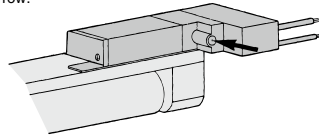

Specific Product Precautions

Be sure to read this before handling the products. Refer to page 9 for safety instructions, pages 10 to 19 for actuator and auto switch precautions, and 3/4/5-port solenoid valve precautions on the SMC website: <https://www.smcworld.com>

Handling Precautions

Caution

- During installation, secure the rod cover and tighten the mounting nut or the rod cover body by applying an appropriate tightening force.**

If the head cover is secured or the head cover is tightened, the cover may rotate, leading to the deviation.

- Tighten the mounting screws with an appropriate tightening torque within the range given below.**

ø6: 2.1 to 2.5 N·m, ø10: 5.9 to 6.4 N·m
ø16: 10.8 to 11.8 N·m

- To remove and install the retaining ring for the knuckle pin or the clevis pin, use an appropriate pair of pliers (tool for installing a type C retaining ring).**

In particular, use a pair of ultra-mini pliers for removing and installing the retaining rings on the ø10 cylinder.

- For the auto switch mounting rail, do not remove the pre-equipped rail.**

Since the mounting thread is drilled through inside the cylinder, it may cause air leakage.

Warning

- Confirm the specifications.**

Products in this catalog are designed to be used for compressed air systems. If not operated within the designated pressure or temperature, it may damage the products or cause malfunction. (Refer to specifications.)

- Energizing continuously for a long period of time**

When the valve is continuously energized for a long period of time, the performance may deteriorate, shorten the service life or effect peripheral equipment adversely since temperature rises when coils generate heat.

CVJ5 Series

Axial Foot Type (L)

CVJ5L

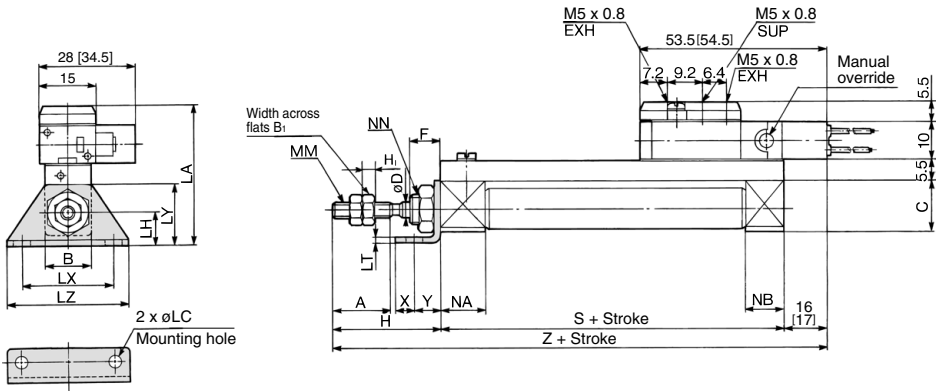

Rod End Nut

Bore size (mm)	B ₁	H ₁
10	7	3.2
16	8	4

* []: Denotes the values of AC.

Bore size	A	B	C	D	F	H	LA	LC	LH	LT	LX	LY	LZ	MM	NA	NB	NN	S	X	Y	Z
10	15	12	14	4	8	28	38	4.5	9	1.6	24	16.5	32	M4 x 0.7	12.5	9.5	M8 x 1	46	5	7	90 [91]
16	15	18	20	5	8	28	46	5.5	14	2.3	33	25	42	M5 x 0.8	12.5	9.5	M10 x 1	47	6	9	91 [92]

Rod Side Flange Type (F)

CVJ5F

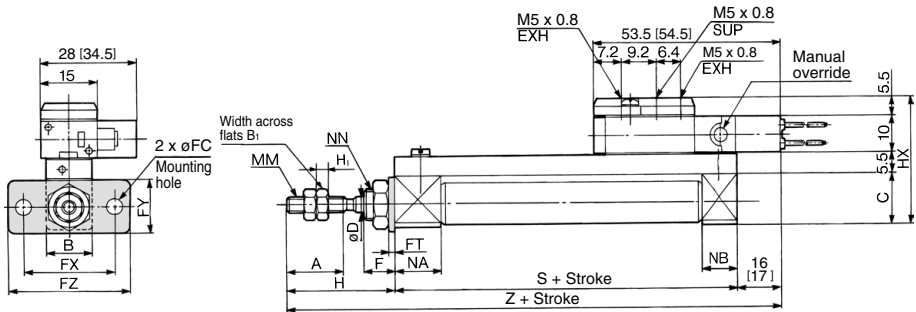

Rod End Nut

Bore size (mm)	B ₁	H ₁
10	7	3.2
16	8	4

* []: Denotes the values of AC.

Bore size	A	B	C	D	F	FC	FT	FX	FY	FZ	H	HX	MM	NA	NB	NN	S	X	Y	Z
10	15	12	14	4	8	4.5	1.6	24	14	32	28	35	M4 x 0.7	12.5	9.5	M8 x 1	46	5	7	90 [91]
16	15	18	20	5	8	5.5	2.3	33	20	42	28	41	M5 x 0.8	12.5	9.5	M10 x 1	47	6	9	91 [92]

CVJ5 Series Accessory Dimensions

Single Knuckle Joint

(mm)

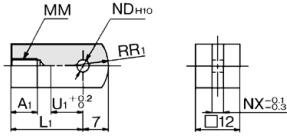

Material: Rolled steel

Part no.	Applicable bore size	A ₁	L ₁	MM	ND ^{H10}	NX	R ₁	U ₁
I-J010C	10	8	21	M4 x 0.7	3.3 ^{+0.048} ₀	3.1	8	9
I-J016C	16	8	25	M5 x 0.8	5 ^{+0.048} ₀	6.4	12	14

Knuckle Pin

(mm)

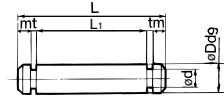

Material: Stainless steel

Part no.	Applicable bore size	Dd9	d	L	L ₁	m	t	Applicable retaining ring
IY-J010	10	3.3 ^{-0.030} _{-0.060}	3	16.2	12.2	1.7	0.3	Type C 3.2
IY-J015	16	5 ^{-0.030} _{-0.060}	4.8	16.6	12.2	1.5	0.7	Type C 5

* Retaining rings are included.

Double Knuckle Joint

(mm)

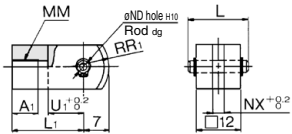

Material: Rolled steel

Part no.	Applicable bore size	A ₁	L	L ₁	MM	ND ₉	ND _{H10}	NX	R ₁	U ₁
Y-J010C	10	8	16.2	21	M4 x 0.7	3.3 ^{-0.030} _{-0.060}	3.3 ^{+0.048} ₀	3.2	8	10
Y-J016C	16	11	16.6	21	M5 x 0.8	5 ^{-0.030} _{-0.060}	5 ^{+0.048} ₀	6.5	12	10

* Knuckle pin and retaining ring are shipped together.

Mounting Nut

(mm)

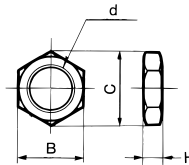

Material: Brass

Part no.	Applicable bore size	B	C	d	H
SNJ-010C	10	11	12.7	M8 x 1.0	4
SNJ-016C	16	14	16.2	M10 x 1.0	4

Rod End Nut

(mm)

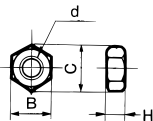

Material: Iron

Part no.	Applicable bore size	B	C	d	H
NTJ-010C	10	7	8.1	M4 x 0.7	3.2
NTJ-015C	16	8	9.2	M5 x 0.8	4

Auto Switch Mounting 1

Auto Switch Proper Mounting Position (Detection at Stroke End) and Its Mounting Height

Solid state auto switch

<Band mounting>

D-M9□

D-M9□W

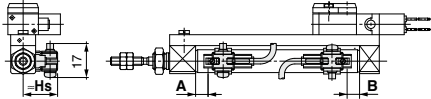

A and B are the dimensions from the end of the head cover/rod cover to the end of the auto switch.

D-H7□

D-H7□W

D-H7NF

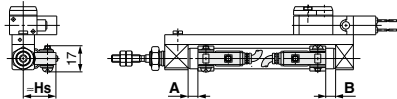

D-H7C

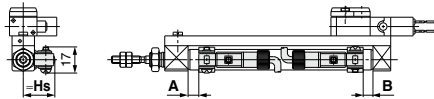

Reed auto switch

<Band mounting>

D-A9□

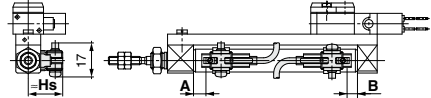

A and B are the dimensions from the end of the head cover/rod cover to the end of the auto switch.

D-C7□/C80

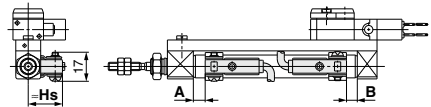

D-C73C□/C80C

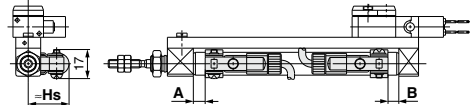

Auto Switch Proper Mounting Position (Detection at Stroke End) and Its Mounting Height

<Rail mounting>

D-M9□
D-M9□W

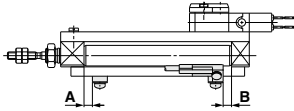
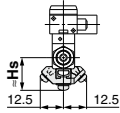

D-M9□V
D-M9□WV

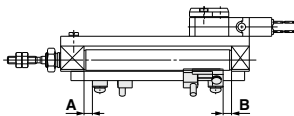
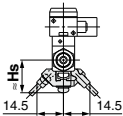

D-F7□/J79
D-F7□W/J79W
D-F79F

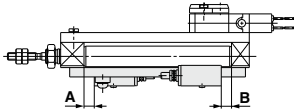
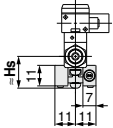

D-F7□V/F7□WV

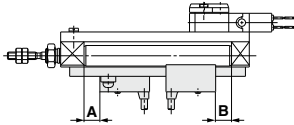
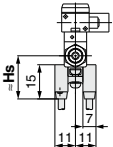

D-J79C

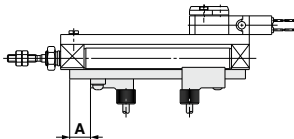
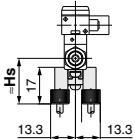

<Rail mounting>

D-A9□

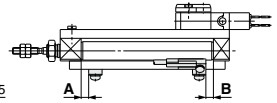
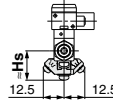

D-A9□V

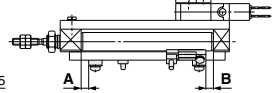
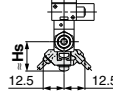

D-A7□/A80

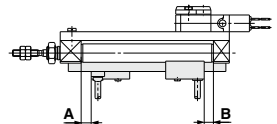
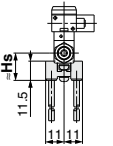

D-A7□H/A80H

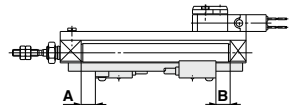
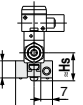

D-A73C/A80C

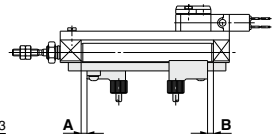
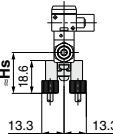

D-A79W

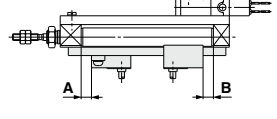
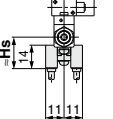

Auto Switch Proper Mounting Position

Auto switch model	Band mounting										Rail mounting									
	D-A9□ D-A9□V		D-M9□ D-M9□V D-M9□W D-M9□WV D-M9□A D-M9□AW		D-C7□ D-C80 D-C73C D-C80C		D-H7□ D-H7C D-H7NF D-H7□W		D-A9□ D-A9□V		D-M9□ D-M9□V D-M9□W D-M9□WV D-M9□AV		D-A7□ D-A80		D-A7□H/A80H D-A73C/A80C D-F7□/J79 D-F7□W/J79W D-F79F/J79C		D-F7NT		D-A79W	
	A	B	A	B	A	B	A	B	A	B	A	B	A	B	A	B	A	B	A	B
Bore size (mm) 10	2	2	6	6	2.5	2.5	1.5	1.5	0.5	0.5	4.5	4.5	3	3	3.5	3.5	8.5	8.5	0.5	0.5
Bore size (mm) 16	2.5	2.5	6.5	6.5	3	3	2	2	1	1	4	4	3.5	3.5	4	4	9	9	1	1

Note) Adjust the auto switch after confirming the operating conditions in the actual setting.

Auto Switch Mounting Height

Auto switch model	Band mounting					Rail mounting						
	D-A9□ D-M9□ D-M9□W D-M9□A	D-M9□V D-M9□WV D-A9□V	D-C7□/C80 D-H7□/H7□W D-H7NF	D-C73C D-C80C	D-H7C Hs	D-A9□/A9□V D-M9□/M9□V D-M9□W D-M9□WV	D-A7□ D-A80	D-A7□H/A80H D-F7□/J79 D-F7□W/J79W D-F79F	D-A73C D-A80C	D-F7□V D-F7□WV	D-J79C Hs	D-A79W Hs
Bore size (mm) 10	17	18	17	19.5	20	17.5	16.5	17.5	23.5	20	23	19
Bore size (mm) 16	20.5	21	20.5	23	23.5	21	19.5	20.5	26.5	23	26	22

Minimum Auto Switch Mounting Stroke

		(mm)				
Auto switch mounting	Auto switch model	No. of auto switches mounted				
		1	2		n (n: No. of auto switches)	
			Different surfaces	Same surface	Different surfaces	Same surface
Band mounting	D-M9□/M9□W D-A9□/M9□A	10	15 ^{Note 1)}	45 ^{Note 1)}	$15 + 35 \frac{(n-2)}{2}$ (n = 2, 4, 6...) ^{Note 4)}	$45 + 15 (n-2)$ (n = 2, 3, 4, 5...)
	D-M9□V	5	15 ^{Note 1)}	35	$15 + 35 \frac{(n-2)}{2}$ (n = 2, 4, 6...) ^{Note 4)}	$35 + 25 (n-2)$ (n = 2, 3, 4, 5...)
	D-M9□WV D-M9□AV	10	15 ^{Note 1)}	35	$15 + 35 \frac{(n-2)}{2}$ (n = 2, 4, 6...) ^{Note 4)}	$35 + 25 (n-2)$ (n = 2, 3, 4, 5...)
	D-A9□V	5	10	35	$10 + 35 \frac{(n-2)}{2}$ (n = 2, 4, 6...) ^{Note 4)}	$35 + 25 (n-2)$ (n = 2, 3, 4, 5...)
	D-C7□ D-C80	10	15	50	$15 + 40 \frac{(n-2)}{2}$ (n = 2, 4, 6...) ^{Note 4)}	$50 + 20 (n-2)$ (n = 2, 3, 4, 5...)
	D-H7□ D-H7□W D-H7NF	10	15	60	$15 + 45 \frac{(n-2)}{2}$ (n = 2, 4, 6...) ^{Note 4)}	$60 + 22.5 (n-2)$ (n = 2, 3, 4, 5...)
	D-C73C D-C80C D-H7C	10	15	65 ^{Note 2)}	$15 + 50 \frac{(n-2)}{2}$ (n = 2, 4, 6...) ^{Note 4)}	$50 + 27.5 (n-2)$ (n = 2, 3, 4, 5...)
Rail mounting	D-M9□V	5	—	5	—	$10 + 10 (n-2)$ (n = 4, 6...) ^{Note 5)}
	D-A9□V	5	—	10	—	$10 + 15 (n-2)$ (n = 4, 6...) ^{Note 5)}
	D-M9□ D-A9□	10	—	10	—	$15 + 15 (n-2)$ (n = 4, 6...) ^{Note 5)}
	D-M9□WV D-M9□AV	10	—	15	—	$15 + 15 (n-2)$ (n = 4, 6...) ^{Note 5)}
	D-M9□W	15	—	15	—	$20 + 15 (n-2)$ (n = 4, 6...) ^{Note 5)}
	D-M9□A	15	—	20	—	$20 + 15 (n-2)$ (n = 4, 6...) ^{Note 5)}
	D-A7□/A80 D-A7□H/A80H D-A73C/A80C	5	—	10	—	$15 + 10 (n-2)$ (n = 4, 6...) ^{Note 5)}
	D-A7□H D-A80H	5	—	10	—	$15 + 15 (n-2)$ (n = 4, 6...) ^{Note 5)}
	D-A79W	10	—	15	—	$10 + 15 (n-2)$ (n = 4, 6...) ^{Note 5)}
	D-F7□ D-J79	5	—	5	—	$15 + 15 (n-2)$ (n = 4, 6...) ^{Note 5)}
	D-F7□V D-J79C	5	—	5	—	$10 + 10 (n-2)$ (n = 4, 6...) ^{Note 5)}
	D-F7□W/J79W D-F79F/F7NT	10	—	15	—	$15 + 20 (n-2)$ (n = 4, 6...) ^{Note 5)}
	D-F7□WV	10	—	15	—	$10 + 15 (n-2)$ (n = 4, 6...) ^{Note 5)}

Note 4) When "n" is an odd number, an even number that is one larger than this odd number is used for the calculation.
 Note 5) When "n" is an odd number, an even number that is one larger than this odd number is used for the calculation.
 However, the minimum even number is 4. So, 4 is used for the calculation when "n" is 1 to 3.

Note 1) Auto switch mounting (The adjustment as shown in the figures below is required with the following stroke ranges.)

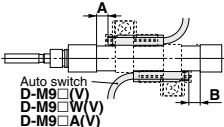
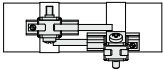
Auto switch model	With 2 auto switches	
	Different surfaces ^{Note 1)}	Same surface ^{Note 1)}
	 <p>The proper auto switch mounting position is 5.5 mm inward from the switch holder edge.</p>	 <p>The auto switch is mounted by slightly displacing it in a direction (cylinder tube circumferential exterior) so that the auto switch and lead wire do not interfere with each other.</p>
D-A93	—	45 to less than 50 stroke
D-M9□ D-M9□W	15 to less than 20 stroke	45 to less than 55 stroke

Note 2) For the CDVJ5 series, note that 65 strokes cannot be manufactured.

Note 3) The dimension stated in () shows the minimum stroke for the auto switch mounting when the auto switch does not project from the end surface of the cylinder body and hinder the lead wire bending space. (Refer to the figure below.)

These contents apply to the rail mounting with one or two auto switches.

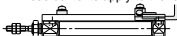

Operating Range

Auto switch model	Bore size (mm)	
	10	16
D-A9□(V)	6	7
D-M9□(V)	2.5	3
D-M9□W(V)/M9□A(V)		
D-C7□/C80/C73C/C80C	7	7
D-H7□/H7□W/H7NF	4	4
D-H7C	8	9

* Since the operating range is provided as a guideline including hysteresis, it cannot be guaranteed (assuming approximately ±30% dispersion). It may vary substantially depending on an ambient environment.

Auto switch model	Bore size (mm)	
	10	16
D-A9□/A9□V	6	6.5
D-M9□/M9□V	3	3.5
D-M9□W/M9□WV		
D-M9□A/M9□AV		
D-A7□/A80/A7H/A80H/A73C/A80C	8	9
D-A79W	11	13
D-F7□/J79/F7□W/J79W	5	5
D-F7□V/F7□WV/F79F/J79C		
D-F7NT		

Auto Switch Mounting Bracket: Part No.

Auto switch mounting	Auto switch model	Bore size (mm)	
		ø10	ø16
Band mounting	D-M9□ D-M9□V D-M9□W D-M9□WV D-A9□ D-A9□V	BJ6-010 <small>Note 1)</small> (A set of a, b, c, d)	BJ6-016 <small>Note 1)</small> (A set of a, b, c, d)
	D-M9□A <small>Note 2)</small> D-M9□AV <small>Note 2)</small>	BJ6-010S <small>Note 2)</small> (A set of a, b, e, f)	BJ6-016S <small>Note 2)</small> (A set of a, b, e, f)
Rail mounting	D-C7□/C80 D-C73C/C80C D-H7□/H7□W D-H7NF	BJ2-010	BJ2-016
	D-A9□ D-A9□V D-M9□ D-M9□V D-M9□W D-M9□WV D-M9□A <small>Note 5)</small> D-M9□AV <small>Note 5)</small>	BQ2-012(S) <small>Note 5)</small>	BQ2-012(S) <small>Note 5)</small>

Note 1) As the switch bracket is made of polyamide, its performance may be affected by chemicals such as alcohol, chloroform, methylamines, hydrochloric acid, and sulfuric acid, so it cannot be used in environments where these chemicals come into contact with the product.

Note 2) For the D-M9□A (V) type auto switch, do not install the switch bracket on the indicator light.

Note 3) Only auto switch mounting brackets are assembled when cylinders are shipped.

Note 4) When a compact auto switch is mounted on the rail mounting type, the auto switch mounting brackets on the left are required. Order them separately from cylinders.

Example order: CDJ2B10-60-A 1 unit
D-M9BWV 2 pcs.

BQ2-012 2 pcs.

Note 5) For the D-M9□A(V), order the BQ2-012S, which uses stainless steel mounting screws.

Besides the models listed in How to Order, the following auto switches are applicable. Refer to pages 1341 to 1435 for detailed specifications.

Auto switch type	Part no.	Electrical entry (Fetching direction)	Features
Reed	D-C73, C76	Grommet (In-let)	—
	D-C80		Without indicator light
Solid state	D-H7A1, H7A2, H7B		—
	D-H7NW, H7PW, H7BW		Diagnostic indication (2-color)

* For solid state auto switches, auto switches with a pre-wired connector are also available. Refer to pages 1410 and 1411 for details.

* Normally closed (NC = b contact) solid state auto switches (D-M9□E(V)) are also available. Refer to page 1360 for details.

Valve Mounted Cylinder Single Acting, Spring Return/Extend

CVJ3 Series

ø10, ø16

How to Order

Stroke (mm)

ø10	15, 30, 45, 60
ø16	15, 30, 45, 60

Mounting type

B	Basic type
L	Axial foot type
F	Rod side flange type

Bore size

10	10 mm
16	16 mm

Electrical entry

G	Grommet
L	L plug connector
M	M plug connector

Light/Surge voltage suppressor

Nil	Without light/surge voltage suppressor
S	With surge voltage suppressor
Z	With light/surge voltage suppressor
R	With surge voltage suppressor (No polarity)
U	With light/surge voltage suppressor (No polarity)

* Type "R", "U": DC only
* In the case of AC, since the rectifier prevents the production of surge voltage, there is no type "S".

CVJ3 L 16 - 60 S - 5 L

With auto switch CDVJ3 L 16 - 60 S - 5 L - M9BW - C

With auto switch (Built-in magnet)

Action

S	Single acting, Spring return
T	Single acting, Spring extend

Solenoid valve voltage

DC specifications	AC specifications (50/60 Hz)
5 24 VDC	1 100 VAC
6 12 VDC	2 200 VAC
V 6 VDC	3 110 VAC (115 VAC)
S 5 VDC	4 220 VAC (230 VAC)
R 3 VDC	

Built-in Magnet Cylinder Model

Suffix the symbol "B" (Band mounting type) or "A" (Rail mounting type) to the end of the w/ auto switch cylinder part number.

Example	Band mounting type	CDVJ3B10-45-B
	Rail mounting type	CDVJ3B16-60-A

Auto switch

Magnet installed even without auto switch

Symbol	Auto switch mounting
A	Rail mounting type
B	Band mounting type

Auto switch mounting bracket (Note)

Note) This symbol is indicated when the D-A9□ or M9□ type auto switch is specified. This mounting bracket does not apply to other auto switches (D-C7□ and H7□, etc.) (Nil)

Number of auto switches

Nil	2 pcs.
S	1 pc.
n	"n" pcs.

Made to Order

Refer to page 1165 for details.

Applicable Auto Switch/Refer to pages 1341 to 1435 for further information on auto switches.

Type	Special function	Electrical entry	Indicator light	Wiring (Output)	Load voltage		Auto switch model				Lead wire length (m)				Pre-wired connector	Applicable load		
					DC	AC	Band mounting		Rail mounting		0.5 (Nil)	1 (M)	3 (L)	5 (Z)			None (N)	
							Perpendicular	In-line	Perpendicular	In-line								
Solid state auto switch	—	Grommet	—	3-wire (NPN)	5 V, 12 V	—	M9NV	M9N	—	—	●	●	●	○	—	○	IC circuit	
							—	—	F7NV	F79	—	—	—	—	—	—		
				M9PV			M9P	—	—	●	●	●	○	—	○			
		—		—			F7PV	F7P	—	—	—	—	—	—				
		M9BV		M9B			—	—	●	●	●	○	—	○				
		—		—			F7BV	J79	—	—	—	—	—	—				
	Diagnostic indication (2-color indicator)	Connector	Yes	24 V	3-wire (NPN)	5 V, 12 V	—	M9NWV	M9NW	—	—	●	●	●	○	—	○	IC circuit
								—	—	F7NWV	F79W	—	—	—	—	—	—	
					M9PWV			M9PW	—	—	●	●	●	○	—	○		
		—			—			F7PV	F7P	—	—	—	—	—	—			
		M9BVV			M9BV			—	—	●	●	●	○	—	○			
		—			—			F7BVV	J79W	—	—	—	—	—	—			
Water resistant (2-color indicator)	Grommet	No	24 V	3-wire (NPN)	5 V, 12 V	—	M9NAV ^{*1}	M9NA ^{*1}	—	—	○	○	○	○	—	○	IC circuit	
							M9PAV ^{*1}	M9PA ^{*1}	—	—	○	○	○	○	—	○		
				M9BAV ^{*1}			M9BA ^{*1}	—	—	○	○	○	○	—	○			
	—			—			F79F	—	—	—	—	—	—	—				
	—			—			A96V	A96	—	—	●	●	●	○	—	○		
	—			—			A72	A72H	—	—	●	●	●	○	—	○		
With diagnostic output (2-color indicator)	Grommet	Yes	24 V	3-wire (NPN equivalent)	5 V, 12 V	—	A96V	A96	—	—	●	●	●	○	—	○	IC circuit	
							—	—	A72	A72H	—	—	—	—	—	—		
				—			—	A73	A73H	—	—	●	●	●	○	—		○
	—			—			A90V	A90	A80	A80H	—	—	—	—	—	—		
	—			—			C73C	A73C	—	—	●	●	●	○	—	○		
	—			—			C80C	A80C	—	—	●	●	●	○	—	○		
Diagnostic indication (2-color indicator)	Grommet	Yes	24 V	2-wire	12 V	—	A93V	A93	A73	A73H	—	—	—	—	—	—	IC circuit	
							A90V	A90	A80	A80H	—	—	—	—	—			
				—			—	C73C	A73C	—	—	●	●	●	○	—		○
	—			—			C80C	A80C	—	—	●	●	●	○	—	○		
	—			—			A79W	—	—	—	●	●	●	○	—	○		
	—			—			—	—	—	—	—	—	—	—	—	—		

*1 Water resistant type auto switches can be mounted on the above models, but in such case SMC cannot guarantee water resistance.
 *2 The load voltage used is 24 VDC.
 * Lead wire length symbols: 0.5 m..... Nil (Example) M9NW
 1 m..... M (Example) M9NWM
 3 m..... L (Example) M9NWL
 5 m..... Z (Example) M9NWZ

* Auto switches marked with "○" are produced upon receipt of order.
 * D-A9□/M9□/A7□/A8□/A6□/7□/□/□ auto switches are shipped together (not assembled). (For D-A9□/M9□, only auto switch mounting brackets are assembled before shipped.)
 * D-C7□/C80□/H7□ auto switches are assembled at the time of shipment.
 * Order auto switch mounting brackets separately when D-A9□(V)/M9□(V)/M9□(V)/M9□(A)(V) are mounted on ø10 and ø16 of the rail mounting type. Refer to page 1174 for details.

* Since there are other applicable auto switches than listed, refer to page 1174 for details.
 * For details about auto switches with pre-wired connector, refer to pages 1410 and 1411.



Valve Mounted Cylinder **CVJ3 Series**

An auto switch cylinder with the switch installed can also be manufactured.

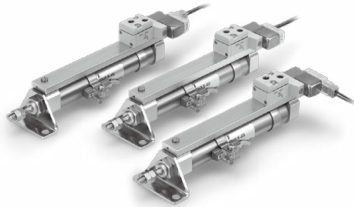

Symbol

Single acting:
Spring return, Rubber bumper

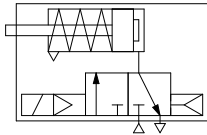

Single acting:
Spring extend, Rubber bumper

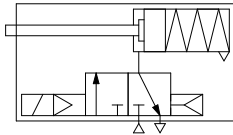

Made to Order Specifications

[Click here for details](#)

Symbol	Specifications
-XA□	Change of rod end shape

Specifications

Bore size (mm)	ø10	ø16
Action	Single acting, Single rod, Spring return/Spring extend	
Fluid	Air	
Proof pressure	1.05 MPa	
Maximum operating pressure	0.7 MPa	
Minimum operating pressure	0.15 MPa	
Ambient and fluid temperature	-10 to 50°C (No freezing)	
Cushion	Rubber bumper	
Lubrication	Not required (Non-lube)	
Stroke length tolerance	$+1.0$ 0	
Port size	M5 x 0.8	
Mounting	Basic type, Axial foot type, Rod side flange type	
Piston speed	50 to 750 mm/s	50 to 350 mm/s
Allowable kinetic energy	0.035 J	0.090 J

Solenoid Valve Specifications

Applicable solenoid valve model		SYJ319	
Electrical entry		Grommet (G), L plug connector (L), M plug connector (M)	
Coil rated voltage (V)	DC	24, 12, 6, 5, 3	
	AC 50/60 Hz	100, 110, 200, 220	
Effective area of valve (Cv factor)		1.8 mm ² (0.1)	
Allowable voltage		±10% of the rated voltage*	
Power consumption (W)	DC	Standard	
		0.35 (With indicator light: 0.4)	
Apparent power (VA)*	AC	100 V	0.78 (With indicator light: 0.81)
		110 V [115 V]	0.86 (With indicator light: 0.89) [0.94 (With indicator light: 0.97)]
		200 V	1.18 (With indicator light: 1.22)
		220 V [230 V]	1.30 (With indicator light: 1.34) [1.42 (With indicator light: 1.46)]
Surge voltage suppressor		Diode (Varistor for the non-polar type)	
Indicator light		LED	

* 110 VAC and 115 VAC types and 220 VAC and 230 VAC types are common respectively.

* For 115 VAC and 230 VAC, allowable voltage fluctuation is -15 to +5 % of the rated voltage.

* For S and Z, the voltage will drop due to the internal circuit. Allowable voltage fluctuation must be in the range below.

Types S, Z 24 VDC: -7 to 10 %, 12 VDC: -4 to 10 %

Standard Stroke

(mm)

Bore size (mm)	Standard stroke
10	15, 30, 45, 60
16	15, 30, 45, 60

Spring Back Force

(N)

Bore size (mm)	Spring reaction force	
	Secondary	Primary
10	6.9	3.5
16	14.2	6.9

CVJ3 Series

Mounting Type and Accessory/For details, refer to page 1159.

	Mounting	Basic type	Axial foot type	Rod side flange type
Standard equipment	Mounting nut	●	●	●
	Rod end nut	●	●	●
Option	Single knuckle joint	○	○	○
	Double knuckle joint (With pin)*	○	○	○

* Knuckle pin and retaining ring are shipped together. ●...Supplied with the product. ○...Please order separately.

Accessory

Accessories of the CVJ3 series are the same specifications as those of the CVJ5 series. Refer to page 1159.

Mounting Bracket Part No.

Mounting bracket	Bore size (mm)	
	10	16
Foot	CJ-L010C	CJ-L016C
Flange	CJ-F010C	CJ-F016C

Accessory (Option)

Refer to page 1159 for part numbers and dimensions of the single knuckle joint, double knuckle joint, knuckle pin, mounting nut, and rod end nut.

Weight

Spring Return (g)

Bore size (mm)		10	16
Basic weight*	15 stroke	79	116
	30 stroke	87	135
	45 stroke	97	159
	60 stroke	109	184
Mounting bracket weight	Axial foot type	7	19
	Rod side flange type	5	13

* Mounting nut and rod end nut are included in the basic weight.

Calculation: (Example) **CVJ3L10-45T**

- Basic weight 97 (g) (ø10-45 stroke)
- Mounting bracket weight 7 (g) (Axial foot type)
- 97 + 7 = 104 g

Spring Extend (g)

Bore size (mm)		10	16
Basic weight*	15 Stroke	75	111
	30 Stroke	82	129
	45 Stroke	93	151
	60 Stroke	103	175
Mounting bracket weight	Axial foot type	7	19
	Rod side flange type	5	13

* Mounting nut and rod end nut are included in the basic weight.

Calculation: (Example) **CVJ3L10-45T**

- Basic weight 93 (g) (ø10-45 stroke)
- Mounting bracket weight 7 (g) (Axial foot type)
- 93 + 7 = 100 g

Manual Operation

Manual operation is possible by pushing the manual button indicated with the arrow.

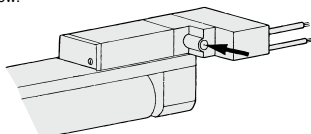

Specific Product Precautions

Be sure to read this before handling the products. Refer to page 9 for safety instructions, pages 10 to 19 for actuator and auto switch precautions, and 3/4/5-port solenoid valve precautions on the SMC website: <https://www.smcworld.com>

Handling Precautions

Caution

1. During installation, secure the rod cover and tighten the mounting nut or the rod cover body by applying an appropriate tightening force.

If the head cover is secured or the head cover is tightened, the cover may rotate, leading to the deviation.

2. Tighten the mounting screws with an appropriate tightening torque within the range given below.

ø6: 2.1 to 2.5 N·m, ø10: 5.9 to 6.4 N·m
ø16: 10.8 to 11.8 N·m

3. Do not operate the single acting cylinder in such a way that a load would be applied when retracting the piston rod of the spring return type or extending the piston rod of the spring extend type.

The spring that is built into the cylinder provides only enough force to retract the piston rod. If a load is applied, the piston rod will not be able to retract to the stroke end.

4. For the single acting cylinder, a breather hole is provided in the cover surface. Do not block this hole during installation.

This may cause malfunction.

5. To remove and install the retaining ring for the knuckle pin or the clevis pin, use an appropriate pair of pliers (tool for installing a type C retaining ring).

In particular, use a pair of ultra-mini pliers for removing and installing the retaining rings on the ø10 cylinder.

6. For the auto switch mounting rail, do not remove the pre-equipped rail.

Since the mounting thread is drilled through inside the cylinder, it may cause air leakage.

Warning

1. Confirm the specifications.

Products in this catalog are designed to be used for compressed air systems. If not operated within the designated pressure or temperature, it may damage the products or cause malfunction. (Refer to specifications.)

2. Energizing continuously for a long period of time

When the valve is continuously energized for a long period of time, the performance may deteriorate, shorten the service life or effect peripheral equipment adversely since temperature rises when coils generate heat.

Construction/Component Parts

Single acting, Spring return

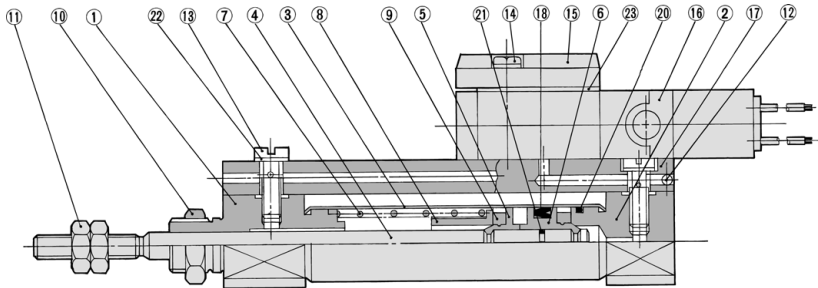

Single acting, Spring extend

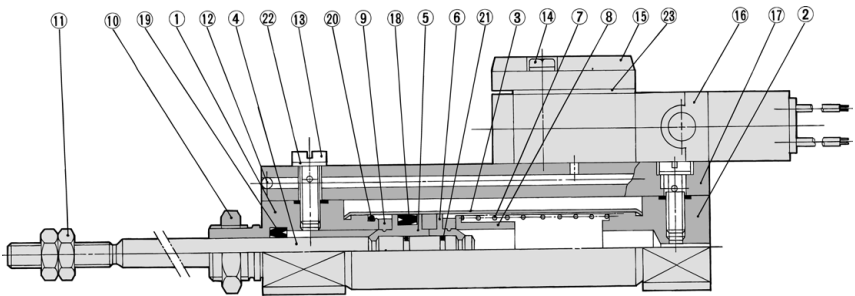

Component Parts

No.	Description	Material	Note
1	Rod cover	Aluminum alloy	Clear anodized
2	Head cover	Aluminum alloy	Clear anodized
3	Cylinder tube	Stainless steel	
4	Piston rod	Stainless steel	
5	Piston A	Aluminum alloy	Chromated
6	Piston B	Aluminum alloy	Chromated
7	Return spring	Piano wire	
8	Spring seat	Brass	
9	Bumper	Urethane	
10	Mounting nut	Brass	Nickel plated
11	Rod end nut	Rolled steel	Zinc chromated
12	Steel ball	Carbon steel	

No.	Description	Material	Note
13	Stud	Brass	Electroless nickel plated
14	Phillips screw	Rolled steel	Nickel plated
15	Plate	Zinc alloy	
16	Solenoid valve	—	Refer to "How to Order" below.*
17	Pipe	Aluminum alloy	Clear anodized
18	Piston seal	NBR	
19	Rod seal	NBR	
20	Tube gasket	NBR	
21	Piston gasket	NBR	
22	Gasket	NBR + Stainless steel 304	
23	Plate gasket	NBR	

* How to Order solenoid valves
SYJ319 - □□□□

Rated voltage • Light/surge voltage suppressor
• Electrical entry

Single Acting, Spring Extend/Basic Type (B)

CVJ3B **Bore size** - **Stroke** T

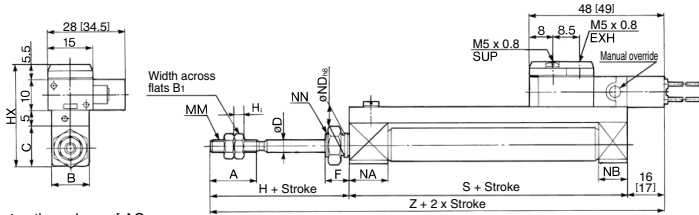

Rod End Nut

Bore size (mm)	B ₁	H ₁
10	7	3.2
16	8	4

* []: Denotes the values of AC.

Bore size	A	B	C	D	F	H	HX	MM	NA	NB	ND	NN	5 to 15 st		16 to 30 st		31 to 45 st		46 to 60 st	
													S	Z	S	Z	S	Z	S	Z
10	15	12	14	4	8	28	34.5	M4 x 0.7	12.5	9.5	8 ⁰ _{-0.022}	M8 x 1	52.5	96.5 [97.5]	60	104 [105]	72	116 [117]	84	128 [129]
16	15	18	20	5	8	28	40.5	M5 x 0.8	12.5	9.5	10 ⁰ _{-0.022}	M10 x 1	52.5	96.5 [97.5]	61	105 [106]	73	117 [118]	85	129 [130]

Single Acting, Spring Extend/Axial Foot Type (L)

CVJ3L **Bore size** - **Stroke** T

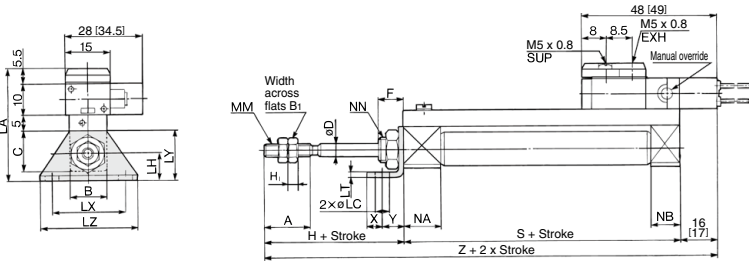

Rod End Nut

Bore size (mm)	B ₁	H ₁
10	7	3.2
16	8	4

* []: Denotes the values of AC.

Bore size	A	B	C	D	F	H	LA	LB	LC	LH	LT	LX	LY	LZ	MM	NA	NB	NN	X	Y	5 to 15 st		16 to 30 st		31 to 45 st		46 to 60 st	
																					S	Z	S	Z	S	Z	S	Z
10	15	12	14	4	8	28	37.5	15	4.5	9	1.6	24	16.5	32	M4 x 0.7	12.5	9.5	M8 x 1	5	7	52.5	96.5 [97.5]	60	104 [105]	72	116 [117]	84	128 [129]
16	15	18	20	5	8	28	45.5	23	5.5	14	2.3	33	25	42	M5 x 0.8	12.5	9.5	M10 x 1	6	9	52.5	96.5 [97.5]	61	105 [106]	73	117 [118]	85	129 [130]

Single Acting, Spring Extend/Rod Side Flange Type (F)

CVJ3F **Bore size** - **Stroke** T

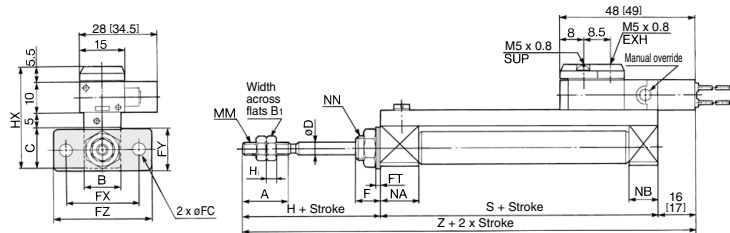

Rod End Nut

Bore size (mm)	B ₁	H ₁
10	7	3.2
16	8	4

* []: Denotes the values of AC.

Bore size	A	B	C	D	F	FC	FT	FX	FY	FZ	H	HX	MM	NA	NB	NN	5 to 15 st		16 to 30 st		31 to 45 st		46 to 60 st	
																	S	Z	S	Z	S	Z	S	Z
10	15	12	14	4	8	4.5	1.6	24	14	32	28	34.5	M4 x 0.7	12.5	9.5	M8 x 1	52.5	96.5 [97.5]	60	104 [105]	72	116 [117]	84	128 [129]
16	15	18	20	5	8	5.5	2.3	33	20	42	28	40.5	M5 x 0.8	12.5	9.5	M10 x 1	52.5	96.5 [97.5]	61	105 [106]	73	117 [118]	85	129 [130]

Auto Switch Mounting 1

Auto Switch Proper Mounting Position (Detection at Stroke End) and Its Mounting Height

Solid state auto switch

<Band mounting>

D-M9□

D-M9□W

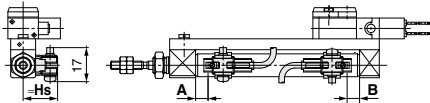

A and B are the dimensions from the end of the head cover/rod cover to the end of the auto switch.

D-H7□

D-H7□W

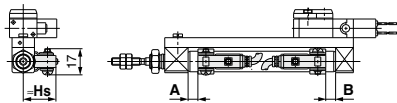

D-H7C

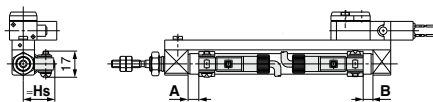

Reed auto switch

<Band mounting>

D-A9□

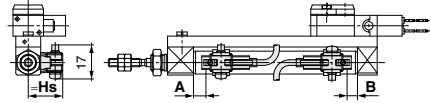

A and B are the dimensions from the end of the head cover/rod cover to the end of the auto switch.

D-C7□/C80

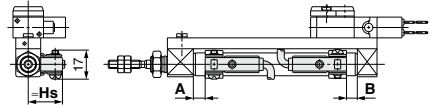

D-C73C□/C80C

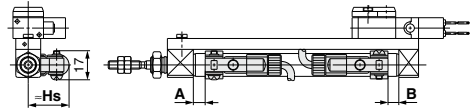

Auto Switch Proper Mounting Position (Detection at Stroke End) and Its Mounting Height

<Rail mounting>

D-M9□
D-M9□W

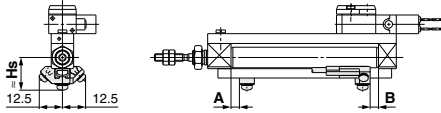

D-M9□V
D-M9□WV

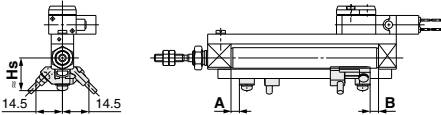

D-F7□/J79
D-F7□W/J79W
D-F79F

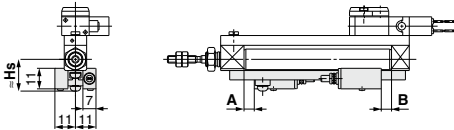

D-F7□V/F7□WV

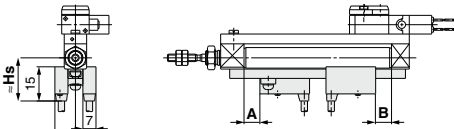

(): For D-F7□WV type

D-J79C

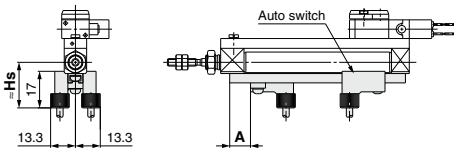

<Rail mounting>

D-A9□

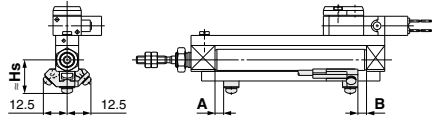

D-A9□V

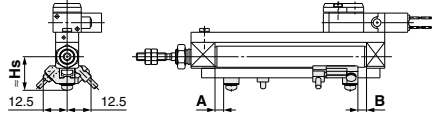

D-A7□/A80

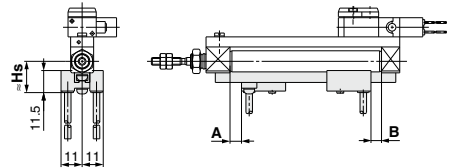

D-A7□H/A80H

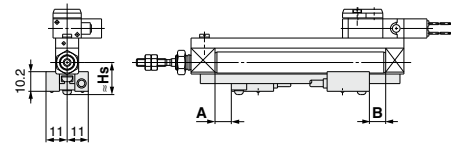

D-A73C/A80C

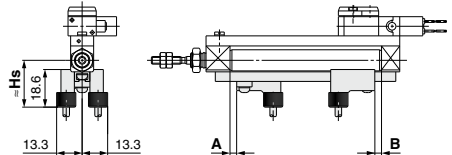

D-A79W

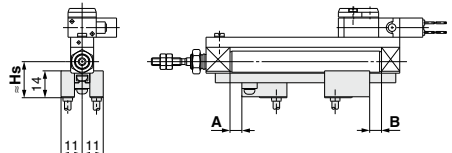

Auto Switch Mounting 2

Auto Switch Proper Mounting Position (Detection at Stroke End) and Its Mounting Height: Single Acting, Spring Return (S) / Spring Extend (T)

Auto Switch Proper Mounting Position / Spring Return (S) (mm)

Auto switch model	Bore size (mm)	Dimension A				B		
		10 to 15 st	16 to 30 st	31 to 45 st	46 to 60 st			
Band mounting	D-A9□(V)	10	8.5	16	28	40	2	
		16	8	16.5	28.5	40.5	2.5	
	D-M9□(V) D-M9□W(V) D-M9□A(V)	10	12.5	20	32	44	6	
		16	12	20.5	32.5	44.5	6.5	
	D-C7□/C80 D-C73C/C80C	10	9	16.5	28.5	40.5	2.5	
		16	8.5	17	29	41	3	
D-H7□/H7C D-H7□W D-H7NF	10	8	15.5	27.5	39.5	1.5		
	16	7.5	16	28	40	2		
		7	14.5	26.5	38.5	0.5		
Rail mounting	D-A9□ D-A9□V	10	7	14.5	26.5	38.5	0.5	
		16	6.5	15	27	39	1	
	D-M9□/M9□V D-M9□W/M9□WV	10	11	18.5	30.5	42.5	4.5	
		16	10.5	19	31	43	5	
	D-A7□ D-A80	10	9.5	17	29	41	3	
		16	9	17.5	29.5	41.5	3.5	
	D-A7□H/A80H D-A73C/A80C D-F7□/J79 D-F7□W/J79W D-F7□V/F7□WV D-F79F/J79C	10	10	17.5	29.5	41.5	3.5	
			16	9.5	18	30	42	4
			10	15	22.5	34.5	46.5	8.5
		D-F7NT	16	14.5	23	35	47	9
			10	7	14.5	26.5	38.5	0.5
	D-A79W	16	6.5	15	27	39	1	

Note) Adjust the auto switch after confirming the operating conditions in the actual setting.

Auto Switch Proper Mounting Position / Spring Extend (T) (mm)

Auto switch model	Bore size (mm)	A	Dimension B					
			10 to 15 st	16 to 30 st	31 to 45 st	46 to 60 st		
Band mounting	D-A9□(V)	10	2	8.5	16	28	40	
		16	2.5	8	16.5	28.5	40.5	
	D-M9□(V) D-M9□W(V) D-M9□A(V)	10	6	12.5	20	32	44	
		16	6.5	12	20.5	32.5	44.5	
	D-C7□/C80 D-C73C/C80C	10	2.5	9	16.5	28.5	40.5	
		16	3	8.5	17	29	41	
D-H7□/H7C D-H7□W D-H7NF	10	1.5	8	15.5	27.5	39.5		
	16	2	7.5	16	28	40		
		0.5	7	14.5	16.5	38.5		
Rail mounting	D-A9□ D-A9□V	16	1	6.5	15	27	39	
		10	4.5	11	18.5	30.5	42.5	
	D-M9□/M9□V D-M9□W/M9□WV	16	5	10.5	19	31	43	
		10	3	9.5	17	29	41	
	D-A7□ D-A80	16	3.5	9	17.5	29.5	41.5	
		D-A7□H/A80H D-A73C/A80C D-F7□/J79 D-F7□W/J79W D-F7□V/F7□WV D-F79F/J79C	10	3.5	10	17.5	29.5	41.5
	16		4	9.5	18	30	42	
	10		8.5	15	22.5	34.5	46.5	
	D-F7NT		16	9	14.5	23	35	47
			10	0.5	7	14.5	26.5	38.5
	D-A79W	16	1	6.5	15	27	39	

Note) Adjust the auto switch after confirming the operating conditions in the actual setting.

Auto Switch Mounting Height (mm)

Auto switch model	Band mounting					Rail mounting						
	D-A9□ D-M9□ D-M9□W D-M9□A	D-M9□V D-M9□WV D-A9□AV D-A9□V	D-C7□/C80 D-H7□ D-H7□W D-H7NF	D-C73C D-C80C	D-H7C	D-A9□/A9□V D-M9□ D-M9□V D-M9□W D-M9□WV	D-A7□ D-A80	D-A7□H/A80H D-F7□/J79 D-F7□W/J79W D-F79F D-F7NT	D-A73C D-A80C	D-F7□V D-F7□WV	D-J79C	D-A79W
Bore size (mm)	Hs	Hs	Hs	Hs	Hs	Hs	Hs	Hs	Hs	Hs	Hs	Hs
10	17	18	17	19.5	20	17.5	16.5	17.5	23.5	20	23	19
16	20.5	21	20.5	23	23.5	21	19.5	20.5	26.5	23	26	22

Minimum Auto Switch Mounting Stroke

		(mm)				
Auto switch mounting	Auto switch model	1	No. of auto switches mounted		n (n: No. of auto switches)	
			Different surfaces	Same surface	Different surfaces	Same surface
Band mounting	D-M9□/M9□W D-A9□/M9□A	10	15 <small>Note 1)</small>	45 <small>Note 1)</small>	$15 + 35 \frac{(n-2)}{2}$ <small>(n = 2, 4, 6...)</small> <small>Note 4)</small>	45 + 15 (n-2) <small>(n = 2, 3, 4, 5...)</small>
	D-M9□V	5	15 <small>Note 1)</small>	35	$15 + 35 \frac{(n-2)}{2}$ <small>(n = 2, 4, 6...)</small> <small>Note 4)</small>	35 + 25 (n-2) <small>(n = 2, 3, 4, 5...)</small>
	D-M9□WV D-M9□AV	10	15 <small>Note 1)</small>	35	$15 + 35 \frac{(n-2)}{2}$ <small>(n = 2, 4, 6...)</small> <small>Note 4)</small>	35 + 25 (n-2) <small>(n = 2, 3, 4, 5...)</small>
	D-A9□V	5	10	35	$10 + 35 \frac{(n-2)}{2}$ <small>(n = 2, 4, 6...)</small> <small>Note 4)</small>	35 + 25 (n-2) <small>(n = 2, 3, 4, 5...)</small>
	D-C7□ D-C80	10	15	50	$15 + 40 \frac{(n-2)}{2}$ <small>(n = 2, 4, 6...)</small> <small>Note 4)</small>	50 + 20 (n-2) <small>(n = 2, 3, 4, 5...)</small>
	D-H7□ D-H7□W D-H7NF	10	15	60	$15 + 45 \frac{(n-2)}{2}$ <small>(n = 2, 4, 6...)</small> <small>Note 4)</small>	60 + 22.5 (n-2) <small>(n = 2, 3, 4, 5...)</small>
	D-C73C D-C80C D-H7C	10	15	65 <small>Note 2)</small>	$15 + 50 \frac{(n-2)}{2}$ <small>(n = 2, 4, 6...)</small> <small>Note 4)</small>	50 + 27.5 (n-2) <small>(n = 2, 3, 4, 5...)</small>
Rail mounting	D-M9□V	5	—	5	—	10 + 10 (n-2) <small>(n = 4, 6...)</small> <small>Note 5)</small>
	D-A9□V	5	—	10	—	10 + 15 (n-2) <small>(n = 4, 6...)</small> <small>Note 5)</small>
	D-M9□ D-A9□	10	—	10	—	15 + 15 (n-2) <small>(n = 4, 6...)</small> <small>Note 5)</small>
	D-M9□WV D-M9□AV	10	—	15	—	15 + 15 (n-2) <small>(n = 4, 6...)</small> <small>Note 5)</small>
	D-M9□W	15	—	15	—	20 + 15 (n-2) <small>(n = 4, 6...)</small> <small>Note 5)</small>
	D-M9□A	15	—	20	—	20 + 15 (n-2) <small>(n = 4, 6...)</small> <small>Note 5)</small>
	D-A7□/A80 D-A7□H/A80H D-A73C/A80C	5	—	10	—	15 + 10 (n-2) <small>(n = 4, 6...)</small> <small>Note 5)</small>
	D-A7□H D-A80H	5	—	10	—	15 + 15 (n-2) <small>(n = 4, 6...)</small> <small>Note 5)</small>
	D-A79W	10	—	15	—	10 + 15 (n-2) <small>(n = 4, 6...)</small> <small>Note 5)</small>
	D-F7□ D-J79	5	—	5	—	15 + 15 (n-2) <small>(n = 4, 6...)</small> <small>Note 5)</small>
	D-F7□V D-J79C	5	—	5	—	10 + 10 (n-2) <small>(n = 4, 6...)</small> <small>Note 5)</small>
	D-F7□W/J79W D-F79F/F7NT	10	—	15	—	15 + 20 (n-2) <small>(n = 4, 6...)</small> <small>Note 5)</small>
	D-F7□WV	10	—	15	—	10 + 15 (n-2) <small>(n = 4, 6...)</small> <small>Note 5)</small>

Note 4) When "n" is an odd number, an even number that is one larger than this odd number is used for the calculation.
 Note 5) When "n" is an odd number, an even number that is one larger than this odd number is used for the calculation.
 However, the minimum even number is 4. So, 4 is used for the calculation when "n" is 1 to 3.

Note 1) Auto switch mounting (The adjustment as shown in the figures below is required with the following stroke ranges.)

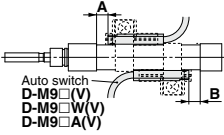
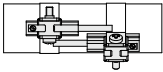
Auto switch model	With 2 auto switches	
	Different surfaces <small>Note 1)</small>	Same surface <small>Note 1)</small>
 <p style="text-align: center;">Auto switch D-M9□(V) D-M9□W(V) D-M9□A(V)</p> <p style="text-align: center;">The proper auto switch mounting position is 5.5 mm inward from the switch holder edge.</p>	 <p style="text-align: center;">The auto switch is mounted by slightly displacing it in a direction (cylinder tube circumferential exterior) so that the auto switch and lead wire do not interfere with each other.</p>	
D-A93	—	45 to less than 50 stroke
D-M9□ D-M9□W	15 to less than 20 stroke	45 to less than 55 stroke

Note 2) For the CDVJ3 series, note that 65 strokes cannot be manufactured.

Note 3) The dimension stated in () shows the minimum stroke for the auto switch mounting when the auto switch does not project from the end surface of the cylinder body and hinder the lead wire bending space. (Refer to the figure below.)

These contents apply to the rail mounting with one or two auto switches.

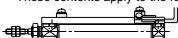

Auto Switch Mounting 3

Operating Range

Auto switch model	Bore size (mm)	
	10	16
Band mounting		
D-A9□(V)	6	7
D-M9□(V)	2.5	3
D-M9□W(V)/M9□A(V)		
D-C7□/C80/C73C/C80C	7	7
D-H7□/H7□W/H7NF	4	4
D-H7C	8	9

* Since the operating range is provided as a guideline including hysteresis, it cannot be guaranteed (assuming approximately ±30% dispersion). It may vary substantially depending on an ambient environment.

Auto switch model	Bore size (mm)	
	10	16
Rail mounting		
D-A9□/A9□V	6	6.5
D-M9□/M9□V	3	3.5
D-M9□W/M9□WV		
D-M9□A/M9□AV		
D-A7□/A80/A7H/A80H/A73C/A80C	8	9
D-A79W	11	13
D-F7□/J79/F7□W/J79W	5	5
D-F7□V/F7□WV/F79F/J79C		
D-F7NT		

Auto Switch Mounting Bracket: Part No.

Auto switch mounting	Auto switch model	Bore size (mm)	
		ø10	ø16
Band mounting	D-M9□ D-M9□V D-M9□W D-M9□WV D-A9□ D-A9□V	BJ6-010 Note 1 (A set of a, b, c, d)	BJ6-016 Note 1 (A set of a, b, c, d)
	D-M9□A Note 2 D-M9□AV Note 2	BJ6-010S Note 2 (A set of a, b, e, f)	BJ6-016S Note 2 (A set of a, b, e, f)
	<p>(1) BJ2-□□□ is a set of "a" and "b". (2) BJ□-1 is a set of "c" and "d". BJ4-1 (Switch bracket: White) BJ5-1 (Switch bracket: Transparent)</p>		
	D-C7□/C80 D-C73C/C80C D-H7□/H7□W D-H7NF	BJ2-010	BJ2-016
Rail mounting	D-A9□ D-A9□V D-M9□ D-M9□V D-M9□W D-M9□WV D-M9□A Note 5 D-M9□AV Note 5	BQ2-012(S) Note 5	BQ2-012(S) Note 5

Note 1) As the switch bracket is made of polyamide, its performance may be affected by chemicals such as alcohol, chloroform, methylamines, hydrochloric acid, and sulfuric acid, so it cannot be used in environments where these chemicals come into contact with the product.

Note 2) For the D-M9□A (V) type auto switch, do not install the switch bracket on the indicator light.

Note 3) Only auto switches are assembled when cylinders are shipped.

Note 4) When a compact auto switch is mounted on the rail mounting type, the auto switch mounting brackets on the left are required. Order them separately from cylinders.

Example order: CDJ2B10-60-A 1 unit
D-M9BW 2 pcs.
BQ2-012 2 pcs.

Note 5) For the D-M9□A(V), order the BQ2-012S, which uses stainless steel mounting screws.

Besides the models listed in How to Order, the following auto switches are applicable. Refer to pages 1341 to 1435 for detailed specifications.

Auto switch type	Part no.	Electrical entry (Fetching direction)	Features
Reed	D-C73, C76	Grommet (In-let)	—
	D-C80		Without indicator light
Solid state	D-H7A1, H7A2, H7B		—
	D-H7NW, H7PW, H7BW		Diagnostic indication (2-color)

* For solid state auto switches, auto switches with a pre-wired connector are also available. Refer to pages 1410 and 1411 for details.

* Normally closed (NC = b contact) solid state auto switches (D-M9□E(V)) are also available. Refer to page 1360 for details.

Valve Mounted Cylinder

Double Acting, Single Rod

CVM5 Series

ø20, ø25, ø32, ø40

How to Order

Bore size

20	20 mm
25	25 mm
32	32 mm
40	40 mm

Rated voltage

DC		AC (50/60 Hz)	
5	24 VDC	1	100 VAC
6	12 VDC	2	200 VAC
V	6 VDC	3	110 VAC (115 VAC)
S	5 VDC	4	220 VAC (230 VAC)
R	3 VDC		

* For the DC specification DIN terminal, only 24 and 12 VDC are available.

Mounting type

B	Basic type
L	Axial foot type
F	Rod side flange type
G	Head side flange type
C	Single clevis type
D	Double clevis type
T	Head side trunnion type
U	Rod side trunnion type

Type of actuation

1	2 position single
2	2 position double
3	3 position closed center
4	3 position exhaust center

Electrical entry

G	Grommet
L	L plug connector
M	M plug connector
D	DIN terminal

Light/Surge voltage suppressor

Electrical entry for G, L, M

Nil	Without light/surge voltage suppressor
S	With surge voltage suppressor
Z	With light/surge voltage suppressor
R	With surge voltage suppressor (Non-polar type)
U	With light/surge voltage suppressor (Non-polar type)

* For AC voltage valves there is no "S" option. It is already built-in to the rectifier circuit.
* For "R" and "U", DC voltage is only available.

Electrical entry for D

Nil	Without light/surge voltage suppressor
S	With surge voltage suppressor (Non-polar type)
Z	With light/surge voltage suppressor (Non-polar type)

* For AC voltage valves there is no "S" option. It is already built-in to the rectifier circuit.

Manual override

Nil	Non-locking push type
D	Push-turn locking slotted type
E	Push-turn locking lever type

Made to Order
Refer to page 1176 for details.

Port thread type

Nil	Nil
TN	NPT
TF	G

Piping

Nil	Screw-in type
F	Built-in One-touch fitting

Rod extended/retracted when energized

Nil	Rod extended when energized
B	Rod retracted when energized

* Only in case of 2 position single solenoid valve.

Suffix for cylinder

Nil	None
J	Nylon tarpaulin
K	Heat resistant tarpaulin

Built-in Magnet Cylinder Model
If a built-in magnet cylinder without an auto switch is required, there is no need to enter the symbol for the auto switch.
(Example) CDVM5B25-150-25GS

Auto switch

Nil	Without auto switch
-----	---------------------

* For the applicable auto switch model, refer to the table below.

Auto switch mounting bracket
(Note)
This symbol is indicated when the D-A9□ or M9□ type auto switch is specified. This mounting bracket does not apply to other auto switches (D-C7□ and H7□, etc.) (Nil)

Number of auto switches

Nil	2 pcs.
S	1 pc.
n	"n" pcs.

Cylinder stroke (mm)
(Refer to "Standard Stroke" on page 1176.)

Ordering Example:
CVM5 L 32 100 1 1 G Z M9BW C

With auto switch: CDVM5 L 32 100 1 1 G Z M9BW C

Applicable Auto Switches

Refer to pages 1341 to 1435 for further information on auto switches.

Type	Special function	Electrical entry	Indicator light	Wiring (Output)	Load voltage		Auto switch model		Lead wire length (m)				Pre-wired connector	Applicable load		
					DC	AC	Perpendicular	In-line	0.5	1	3	5				
									(Nil)	(M)	(L)	(Z)			(N)	
Solid state auto switch		Grommet		3-wire (NPN)	5 V, 12 V		M9NV	M9N	●	●	●	●	○	IC circuit		
				3-wire (PNP)			M9PV	M9P	●	●	●	●	○			
		Connector		2-wire	12 V		M9BV	M9B	●	●	●	●	○	—		
							H7C	●	—	●	●	—				
	Diagnostic indication (2-color indicator)	Grommet	Yes	3-wire (NPN)	5 V, 12 V	—	M9NWV	M9NW	●	●	●	○	○	IC circuit		
				3-wire (PNP)			M9PWV	M9PW	●	●	●	○	○			
	Water resistant (2-color indicator)	Grommet		2-wire	12 V		M9BWW	M9WB	●	●	●	●	○	—		
				3-wire (NPN)			M9NAV*1	M9NA*1	○	○	○	○	○		IC circuit	
	With diagnostic output (2-color indicator)	Grommet		3-wire (PNP)	5 V, 12 V		M9PAV*1	M9PA*1	○	○	○	○	○	IC circuit		
				2-wire			M9BAV*1	M9BA*1	○	○	○	○	○			
Reed auto switch		Grommet	Yes	3-wire (NPN equivalent)	—	5 V	A96V	A96	●	●	●	●	○	IC circuit		
				2-wire			A93V	A93	●	●	●	●	○		IC circuit	
		Connector	Yes	2-wire	24 V	12 V		100 V	A90V	A90	●	●	●	●		○
								100 V or less	B54	●	●	●	●	○		
	Diagnostic indication (2-color indicator)	Grommet	Yes	2-wire	24 V		100 V, 200 V	B64	●	●	●	●	○	—		
							200 V or less	C73C	●	●	●	●	○			
		Grommet	Yes	2-wire	24 V		24 V or less	C80C	●	●	●	●	○	IC circuit		
								B59W	●	●	●	●	○			

* Lead wire length symbols: 0.5 m Nil (Example) M9NW
1 m M (Example) M9NWM
3 m L (Example) M9NWL
5 m Z (Example) M9NWZ
None N (Example) H7CN

* Auto switches marked with "○" are produced upon receipt of order.
*1 Water resistant type auto switches can be mounted on the above models, but in such case SMC cannot guarantee water resistance.
*2 The load voltage used is 24 VDC.

* Since there are other applicable auto switches than listed, refer to page 1193 for details.
* For details about auto switches with pre-wired connector, refer to pages 1410 and 1411.
* D-A9□/M9□ auto switches are shipped together (not assembled). (Only auto switch mounting brackets are assembled before shipped.)

CVM5 Series

Operation type can be changed to rod extended when energized or rod retracted when energized.

An auto switch cylinder with the switch installed can also be manufactured.

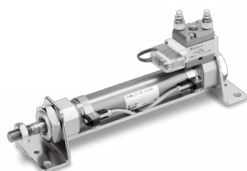

Symbol

Rubber bumper

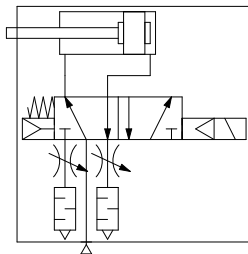

Made to Order Specifications
[Click here for details](#)

Symbol	Specifications
-XA□	Change of rod end shape
-XC4	With heavy duty scraper
-XC6	Made of stainless steel

Refer to pages 1191 to 1193 for cylinders with auto switches.

- Proper auto switch mounting position (detection at stroke end) and mounting height
- Minimum auto switch mounting stroke
- Operating range
- Auto switch mounting bracket: Part no.

Specifications

Applicable bore size (mm)		20	25	32	40
Fluid		Air			
Action		Double acting, Single rod			
Cushion		Rubber bumper			
Proof pressure		1.0 MPa			
Maximum operating pressure		0.7 MPa			
Minimum operating pressure		0.15 MPa			
Ambient and fluid temperature		-10 to 50°C (No freezing)			
Lubrication		Not required (Non-lube)			
Stroke length tolerance		$+1.4$ 0			
Port size	Screw-in type	Rc 1/8			
	Built-in One-touch fitting	O.D.: $\phi 6$ /I.D.: $\phi 4$			
Piston speed (mm/s) ^(Note)		50 to 700*	50 to 650*	50 to 590*	50 to 420*
Allowable kinetic energy		0.27 J	0.4 J	0.65 J	1.2 J
Mounting		Basic type, Axial foot type, Rod side flange type, Head side flange type, Single clevis type, Double clevis type, Head side trunnion type, Rod side trunnion type			

Note) The figures marked with "*" represent the values of the cylinder with the silencer type exhaust throttle valve removed. To operate the cylinder at these values, prevent dust from entering by installing an AN120-M5 silencer on the EXH port.

Solenoid Valve Specifications

Series		SYJ5□90 series	
Manual override		Non-locking push type, Push-turn locking slotted type, Push-turn locking lever type	
Pilot exhaust		Pilot valve individual exh. Type	
Impact/Vibration resistance (m/s ²) ^(Note 1)		150/30	
Enclosure		Dustproof	
Electrical entry		Grommet (G), L plug connector (L), M plug connector (M), DIN terminal (D)	
Coil rated voltage (V)	DC	24, 12, 6, 5, 3	D 24, 12
	AC 50/60 Hz	100, 110, 200, 220	
Allowable voltage		±10% of the rated voltage*	
Power consumption (W) ^(Note 2)		DC 0.35 (With light: 0.4 (DIN terminal with light: 0.45))	
Apparent power (VA) ^(Note 2)	AC	100 V	0.78 (With light: 0.81) 0.78 (With light: 0.87)
		110 V	0.86 (With light: 0.89) 0.86 (With light: 0.97)
		[115 V]	[0.94 (With light: 0.97)] [0.94 (With light: 1.07)]
		200 V	1.18 (With light: 1.22) 1.15 (With light: 1.30)
		220 V	1.30 (With light: 1.34) 1.27 (With light: 1.46)
[230 V]	[1.42 (With light: 1.46)] [1.39 (With light: 1.60)]		
Surge voltage suppressor		Diode (DIN terminal, Varistor when non-polar types)	
Indicator light		LED (Neon light when AC with DIN terminal)	

* Based on IEC60529

* In common between 110 VAC and the 115 VAC, and between 220 VAC and 230 VAC.

* For 115 VAC and 230 VAC, the allowable voltage is -15% to +5% of rated voltage.

Note 1) Impact resistance: No malfunction occurred when it is tested in the axial direction and at the right angles to the main valve and armature in both energized and de-energized states every once for each condition. (Values at the initial period)

Vibration resistance: No malfunction occurred in a one-sweep test between 45 and 2000 Hz. The test was performed at both energized and de-energized states in the axial direction and at the right angles to the main valve and armature. (Values at the initial period)

Note 2) At the rated voltage.

Standard Stroke

Bore size (mm)	Standard stroke (mm) ^(Note)	Maximum stroke (mm)
20	25, 50, 75, 100, 125, 150, 200, 250, 300	1000
25		
32		
40		

Note 1) Other intermediate strokes can be manufactured upon receipt of order.

Note 2) Applicable strokes should be confirmed according to the usage. For details, refer to the CM2 series of the "Air Cylinders Model Selection" in the **Web Catalog**. In addition, the products that exceed the standard stroke might not be able to fulfill the specifications due to the deflection etc.

Rod Boot Material

Symbol	Rod boot material	Maximum ambient temperature
J	Nylon tarpaulin	70°C
K	Heat resistant tarpaulin	110°C*

* Maximum ambient temperature for the rod boot itself.

Weight

(kg)

Bore size (mm)		20	25	32	40
Basic Weight	Basic type	0.22	0.29	0.36	0.64
	Axial foot type	0.37	0.45	0.52	0.91
	Flange type	0.28	0.38	0.45	0.76
	Single clevis type	0.26	0.33	0.40	0.73
	Double clevis type	0.27	0.35	0.41	0.77
	Trunnion type	0.26	0.36	0.42	0.74
Additional weight per each 50 mm of stroke		0.05	0.07	0.09	0.14
Option bracket	Single knuckle joint	0.06	0.06	0.06	0.23
	Double knuckle joint (With pin)	0.07	0.07	0.07	0.20

Calculation: (Example) **CVM5L32-100-11G**

- Basic weight 0.52 (Axial foot type ø32) • Additional weight 0.09/50 st
- Cylinder stroke 100 (st)
- $0.52 + 0.09 \times 100/50 = 0.70$ kg
- Add 0.03 kg for the DIN terminal.
- Add 0.02 kg for the double solenoids.
- Add 0.03 kg for the closed center and exhaust center.

Mounting Type and Accessory

Mounting	Accessory			Standard equipment			Option			
	Mounting nut	Rod end nut	Clevis pin	Single knuckle joint	Double knuckle joint	Pivot bracket ⁽⁵⁾	Pivot bracket pin ⁽⁶⁾			
Basic type	● (1 pc.)	●	—	●	●					
Axial foot type	● (2)	●	—	●	●					
Rod side flange type	● (1)	●	—	●	●					
Head side flange type	● (1)	●	—	●	●					
Single clevis type	— ⁽¹⁾	●	—	●	●	●	●			
Double clevis type ⁽³⁾	— ⁽¹⁾	●	● ⁽⁴⁾	●	●					
Head side trunnion type	● (1) ⁽²⁾	●	—	●	●					
Rod side trunnion type	● (1) ⁽²⁾	●	—	●	●					

Note 1) Mounting nut is not equipped with single clevis type and double clevis type

Note 2) Trunnion nuts are equipped for head side trunnion and rod side trunnion.

Note 3) Pin and set ring are shipped together with double clevis and double knuckle joint.

Note 4) Retaining rings (cotter pins for ø40) are included in clevis pins.

Note 5) Pin and retaining ring are not included in pivot bracket.

Note 6) Retaining rings are included in pivot bracket pin.

Mounting Bracket Part No.

Bore size (mm)	20	25	32	40
Axial foot*	CM-L020B		CM-L032B	CM-L040B
Flange	CM-F020B		CM-F032B	CM-F040B
Single clevis	CM-C020B		CM-C032B	CM-C040B
Double clevis**	CM-D020B		CM-D032B	CM-D040B
Trunnion (With nut)	CM-T020B		CM-T032B	CM-T040B

* Two foot brackets and a mounting nut are attached.

When ordering the foot bracket, order 2 pcs. per cylinder.

** Clevis pin and retaining ring (cotter pin for ø40) are packaged together.

Accessory (Option)

* Refer to page 1190 for part numbers and dimensions of the single knuckle joint, double knuckle joint, clevis pin, knuckle pin, rod end nut, mounting nut, and trunnion nut.

** Refer to page 255 of the CM2-Z series catalog for the part numbers and external dimensions of the pivot bracket and pivot bracket pin as well as for the dimensions when the cylinder is mounted.

⚠️ Precautions

Be sure to read this before handling the products. Refer to page 9 for safety instructions, pages 10 to 19 for actuator and auto switch precautions, and 3/4/5 port solenoid valve precautions on the SMC website: <https://www.smcworld.com>

Mounting

⚠️ Warning

1. Do not rotate the cover.

If a cover is rotated when installing a cylinder or screwing a fitting into the port, it is likely to damage the junction part with cover.

⚠️ Caution

1. Not able to disassemble.

Cover and cylinder tube are connected to each other by caulking method, thus making it impossible to disassemble. Therefore, internal parts of a cylinder other than rod seal are not replaceable.

2. Use caution to the popping of a retaining ring.

When replacing rod seals and removing and mounting a retaining ring, use a proper tool (retaining ring plier: tool for installing type C retaining ring). Even if a proper tool is used, it is likely to inflict damage to a human body or peripheral equipment, as a retaining ring may be flown out of the tip of a plier. Be much careful with the popping of a retaining ring. Besides, be certain that a retaining ring is placed firmly into the groove of rod cover before supplying air at the time of installment.

3. Do not touch the cylinder during operation.

Use caution when handling a cylinder, which is running at a high speed and a high frequency, because the surface of a cylinder tube could get so hot enough as to cause you get burns.

4. Do not use an air cylinder as an air-hydro cylinder.

If it uses turbine oil in place of fluids for cylinder, it may result in oil leakage.

5. Conjoin the rod end part, so that rod boot might not be twisted.

If a rod boot is installed with being twisted when installing a cylinder, it will cause a rod boot to fail during operation.

Model Selection

⚠️ Warning

1. Confirm the specifications.

Products in this catalog are designed to be used for compressed air systems. If not operated within the designated pressure or temperature, it may damage the products or cause malfunction. (Refer to specifications.)

2. Energizing continuously for a long period of time

When the valve is continuously energized for a long period of time, the performance may deteriorate, shorten the service life or affect peripheral equipment adversely since temperature rises when coils generate heat.

CVM5 Series

Built-in One-touch Fitting

CVM5 **Mounting type** **Bore size** **F** — For “How to Order”, refer to page 1175.

● Built-in One-touch fitting

One-touch fittings are installed on cylinders.

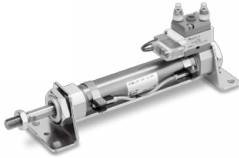

Application/Tubing O.D.

Bore size (mm)	20	25	32	40
Applicable tubing O.D. (mm)	ø6/4	ø6/4	ø6/4	ø6/4
Applicable tubing material	Can be used for either nylon, soft nylon or polyurethane tube.			

Specifications

Action	Double acting, Single rod			
Bore size (mm)	20, 25, 32, 40			
Maximum operating pressure	0.7 MPa			
Minimum operating pressure	0.15 MPa			
Cushion	Rubber bumper			
Piping	Built-in One-touch fitting			
Piston speed (mm/s)	ø20	ø25	ø32	ø40
	50 to 700	50 to 650	50 to 590	50 to 420
Mounting	Basic type, Axial foot type, Rod side flange type, Head side flange type, Single clevis type, Double clevis type, Rod side trunnion type, Head side trunnion type			

For the dimensions of mounting bracket, refer to pages 1181 to 1184.

Opening Range of Throttle Valve and Driving Speed

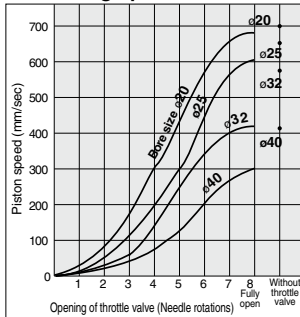

Measuring conditions: Operating pressure 0.5 MPa
Mounting: horizontal Load: no load on the return side
The speeds indicated above are for reference.

Manual Operation

Manual operation is possible by pushing the manual button indicated with the arrow.

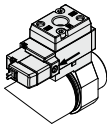

Piston Speed Adjustment

- To slow down the piston speed, screw in the needle of the silencer type exhaust throttle valve clockwise, which reduces the amount of air that is discharged.
- To adjust the piston extension side, regulate the “R1” side silencer type exhaust throttle valve.
To adjust the retraction side, regulate the “R2” side silencer exhaust throttle valve.
- The needle valve of the throttle valve can be fully opened by loosening it 8 turns from the fully closed position.
- The needle valve has a loosening prevention construction.

Changing between Rod Extended when Energized and Rod Retracted when Energized

Step [This procedure is for changing the rod extended when energized to the rod retracted when energized.]

1. Using a tool, loosen the two hexagon socket bolts, and remove the plate and the solenoid valve. At this time, instead of removing the plate and the solenoid valve separately, remove them together, with the hexagon socket bolts remaining inserted.

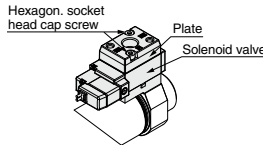

2. A sub-plate gasket is inside the sub-plate. Invert this sub-plate gasket 180° and install it with its letter “B” visible. (A portion that protrudes is provided on the periphery of the sub-plate gasket, and the letter “B” is on one side of this protrusion.)

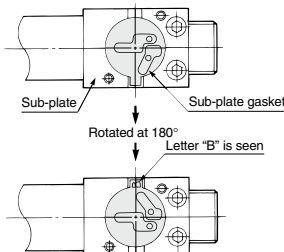

3. Install the solenoid valve and the plate, and tighten the hexagon socket bolts with a tool. The tightening torque is between 0.6 and 0.8 N·m.

After tightening, press the manual button on the solenoid valve, check for any air leaks, and verify the operating conditions. Distinction between rod extended when energized and rod retracted when energized can be determined from the outside, by looking through the small window in the sub-plate.

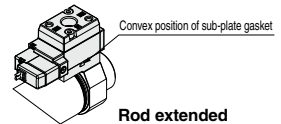

Convex position of sub-plate gasket

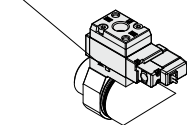

Rod retracted when energized

Construction

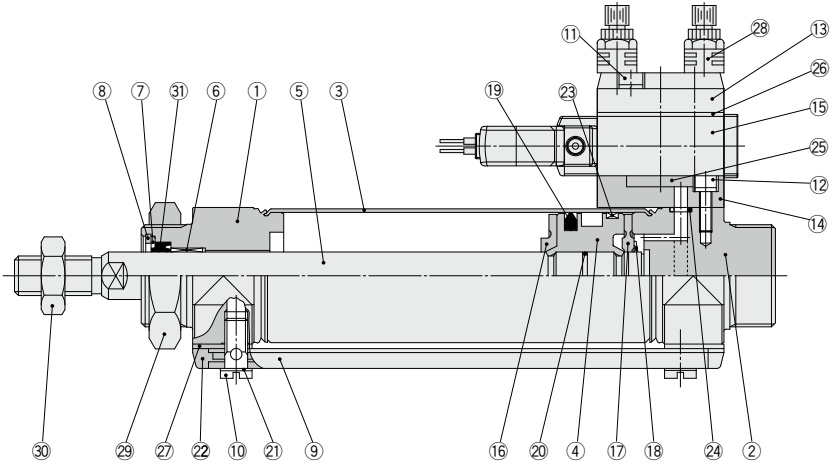

DIN terminal

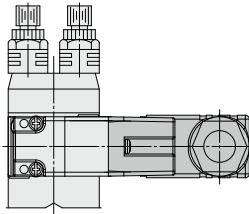

Built-in One-touch fitting

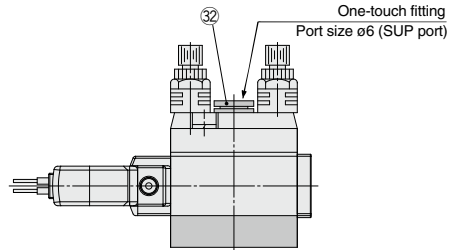

Component Parts

No.	Description	Material	Note
1	Rod cover	Aluminum alloy	Anodized
2	Head cover	Aluminum alloy	Anodized
3	Cylinder tube	Stainless steel	
4	Piston	Aluminum alloy	
5	Piston rod	Carbon steel	Hard chrome plated
6	Bushing	Bearing alloy	
7	Seal retainer	Stainless steel	
8	Retaining ring	Carbon steel	Phosphate coated
9	Pipe	Aluminum alloy	
10	Stud	Brass	Electroless nickel plated
11	Hex. socket head cap screw with spring washer	Stainless steel	
12	Hex. socket head cap screw with spring washer	Stainless steel	
13	Plate	Aluminum alloy	Metallic painted
14	Sub-plate	Aluminum alloy	Metallic painted
15	Solenoid valve	—	Refer to the "How to order" below.*
16	Bumper A	Urethane	
17	Bumper B	Urethane	

* How to order solenoid valves

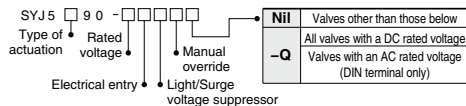

Component Parts

No.	Description	Material	Note
18	Retaining ring	Stainless steel	
19	Piston seal	NBR	
20	Piston gasket	NBR	
21	Gasket	Resin	
22	Pipe gasket	Urethane rubber	
23	Wear ring	Resin	
24	Head cover gasket	NBR	
25	Sub-plate gasket	NBR	
26	Gasket	NBR	
27	Spacer gasket	Resin	Except ø25
28	Exhaust throttle with silencer	—	ASN2-M5
29	Mounting nut	Carbon steel	Nickel plated
30	Rod end nut	Carbon steel	Zinc chromated
32	One-touch fitting	—	Port size: ø6

Replacement Parts/Seal Kit

No.	Description	Material	Part no.			
			20	25	32	40
31	Rod seal	NBR	CM220-PS	CM225-PS	CM232-PS	CM240-PS

* Since the seal kit does not include a grease pack, order it separately.
Grease pack part no.: GR-S-010 (10g)

CVM5 Series

Basic Type (B)

CVM5B —

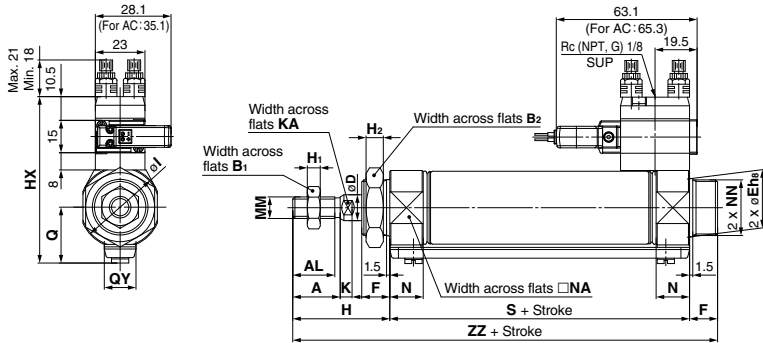

Built-in One-touch fitting

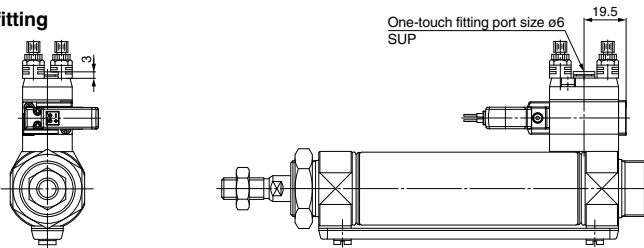

With rod boot

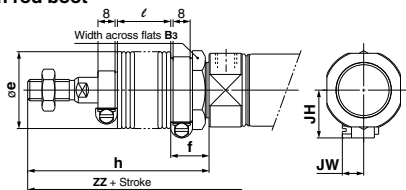

For DIN terminal and double solenoid, refer to page 1184.

Bore size (mm)	Stroke range	A	AL	B ₁	B ₂	D	Eh _s	F	Q	QY	H	H ₁	H ₂	HX	I	K	KA	MM	N	NA	NN	S	ZZ
20	Up to 300	18	15.5	13	26	8	20 ⁰ _{-0.033}	13	19.8	14	41	5	8	65.3	28	5	6	M8 x 1.25	15	24	M20 x 1.5	62	116
25	Up to 300	22	19.5	17	32	10	26 ⁰ _{-0.033}	13	22	14	45	6	8	70.5	33.5	5.5	8	M10 x 1.25	15	30	M26 x 1.5	62	120
32	Up to 300	22	19.5	17	32	12	26 ⁰ _{-0.033}	13	25.8	16	45	6	8	76.5	37.5	5.5	10	M10 x 1.25	15	34.5	M26 x 1.5	64	122
40	Up to 300	24	21	22	41	14	32 ⁰ _{-0.039}	16	29.8	16	50	8	10	84.5	46.5	7	12	M14 x 1.5	21.5	42.5	M32 x 2	88	154

With Rod Boot

Bore size (mm)	B ₃	e	f	h								ℓ				JH	JW		
				1 to 50	51 to 100	101 to 150	151 to 200	201 to 300	301 to 400	401 to 500	1 to 50	51 to 100	101 to 150	151 to 200	201 to 300			301 to 400	401 to 500
20	30	36	18	68	81	93	106	131	156	181	12.5	25	37.5	50	75	100	125	23.5	10.5
25	32	36	18	72	85	97	110	135	160	185	12.5	25	37.5	50	75	100	125	23.5	10.5
32	32	36	18	72	85	97	110	135	160	185	12.5	25	37.5	50	75	100	125	23.5	10.5
40	41	46	20	77	90	102	115	140	165	190	12.5	25	37.5	50	75	100	125	27	10.5

Bore size (mm)	ZZ						
	1 to 50	51 to 100	101 to 150	151 to 200	201 to 300	301 to 400	401 to 500
20	143	156	168	181	206	231	256
25	147	160	172	185	210	235	260
32	149	162	174	187	212	237	262
40	181	194	206	219	244	269	294

* For short strokes, a solenoid valve may protrude from the rod cover end. Confirm S dimension and solenoid dimensions.

* Long stroke type includes ones for strokes more than 301 mm.

Axial Foot Type (L)

CVM5L —

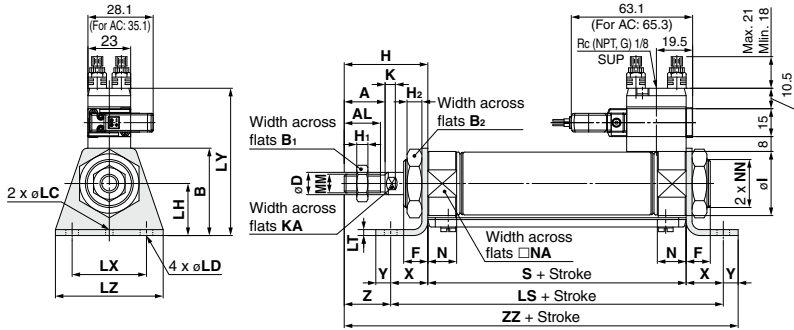

Bore size (mm)	Stroke range	A	AL	B	B ₁	B ₂	D	F	H	H ₁	H ₂	I	K	KA	LC	LD	LH	LS	LT	LX
20	Up to 300	18	15.5	40	13	26	8	13	41	5	8	28	5	6	4	6.8	25	102	3.2	40
25	Up to 300	22	19.5	47	17	32	10	13	45	6	8	33.5	5.5	8	4	6.8	28	102	3.2	40
32	Up to 300	22	19.5	47	17	32	12	13	45	6	8	37.5	5.5	10	4	6.8	28	104	3.2	40
40	Up to 300	24	21	54	22	41	14	16	50	8	10	46.5	7	12	4	7	30	134	3.2	55

(mm)

Bore size (mm)	LY	LZ	MM	N	NA	NN	S	X	Y	Z	ZZ
20	70.5	55	M8 x 1.25	15	24	M20 x 1.5	62	20	8	21	131
25	76.5	55	M10 x 1.25	15	30	M26 x 1.5	62	20	8	25	135
32	78.8	55	M10 x 1.25	15	34.5	M26 x 1.5	64	20	8	25	137
40	84.8	75	M14 x 1.5	21.5	42.5	M32 x 2	88	23	10	27	171

* Brackets are packaged together.

Rod Side Flange Type (F)

CVM5F —

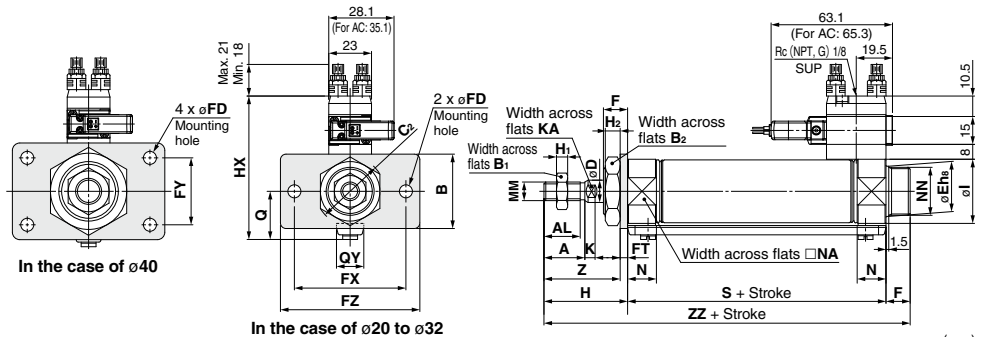

(mm)

Bore size (mm)	Stroke range	A	AL	B	B ₁	B ₂	C ₂	D	Eh ₈	F	FD	FT	FX	FY	FZ	H	H ₁	H ₂	HX
20	Up to 300	18	15.5	34	13	26	30	8	20 ^{0.033}	13	7	4	60	—	75	41	5	8	65.3
25	Up to 300	22	19.5	40	17	32	37	10	26 ^{0.033}	13	7	4	60	—	75	45	6	8	70.5
32	Up to 300	22	19.5	40	17	32	37	12	26 ^{0.033}	13	7	4	60	—	75	45	6	8	76.5
40	Up to 300	24	21	52	22	41	47.3	14	32 ^{0.033}	16	7	5	66	36	82	50	8	10	84.5

(mm)

Bore size (mm)	I	K	KA	MM	N	NA	NN	Q	QY	S	Z	ZZ
20	28	5	6	M8 x 1.25	15	24	M20 x 1.5	19.8	14	62	37	116
25	33.5	5.5	8	M10 x 1.25	15	30	M26 x 1.5	22	14	62	41	120
32	37.5	5.5	10	M10 x 1.25	15	34.5	M26 x 1.5	25.8	16	64	41	122
40	46.5	7	12	M14 x 1.5	21.5	42.5	M32 x 2	29.8	16	88	45	154

* For short strokes, a solenoid valve may protrude from the rod cover end. Confirm S dimension and solenoid dimensions.
* Brackets are packaged together.

CVM5 Series

Head Side Flange Type (G)

CVM5G -

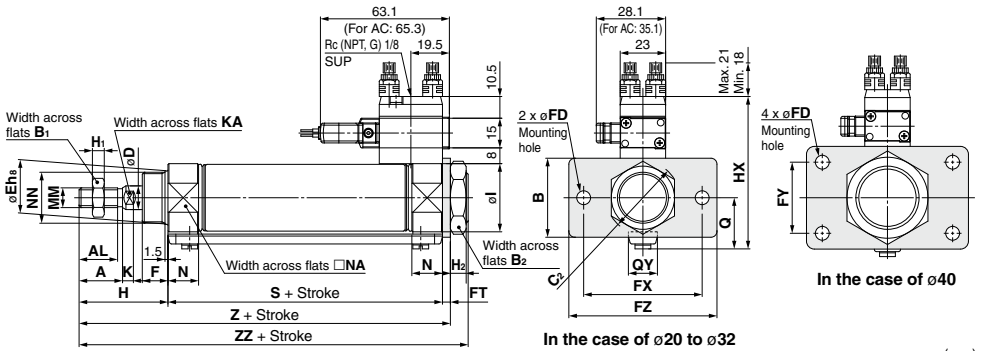

Bore size (mm)	Stroke range	A	AL	B	B ₁	B ₂	C ₂	D	Eh ₈	F	FD	FT	FX	FY	FZ	H	H ₁	H ₂	HX
20	Up to 300	18	15.5	34	13	26	30	8	20 ^{0.033} _{0.033}	13	7	4	60	—	75	41	5	8	65.3
25	Up to 300	22	19.5	40	17	32	37	10	26 ^{0.033} _{0.033}	13	7	4	60	—	75	45	6	8	70.5
32	Up to 300	22	19.5	40	17	32	37	12	26 ^{0.033} _{0.033}	13	7	4	60	—	75	45	6	8	76.5
40	Up to 300	24	21	52	22	41	47.3	14	32 ^{0.039} _{0.039}	16	7	5	66	36	82	50	8	10	84.5

Bore size (mm)	I	K	KA	MM	N	NA	NN	Q	QY	S	Z	Z
20	28	5	6	M8 x 1.25	15	24	M20 x 1.5	19.8	14	62	107	107
25	33.5	5.5	8	M10 x 1.25	15	30	M26 x 1.5	22	14	62	111	111
32	37.5	5.5	10	M10 x 1.25	15	34.5	M26 x 1.5	25.8	16	64	113	113
40	46.5	7	12	M14 x 1.5	21.5	42.5	M32 x 2	29.8	16	88	143	143

* Brackets are packaged together.

Single Clevis Type (C)

CVM5C -

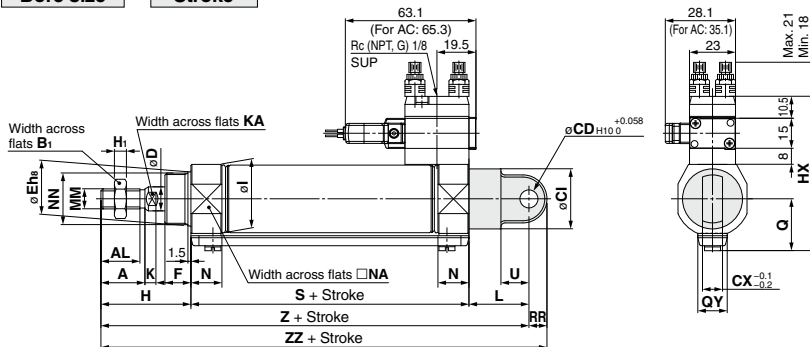

Bore size (mm)	Stroke range	A	AL	B ₁	CD	CI	CX	D	Eh ₈	F	H	H ₁	I	HX	K	KA	L	MM
20	Up to 300	18	15.5	13	9	24	10	8	20 ^{0.033} _{0.033}	13	41	5	28	65.3	5	6	30	M8 x 1.25
25	Up to 300	22	19.5	17	9	30	10	10	26 ^{0.033} _{0.033}	13	45	6	33.5	70.5	5.5	8	30	M10 x 1.25
32	Up to 300	22	19.5	17	9	30	10	12	26 ^{0.033} _{0.033}	13	45	6	37.5	76.5	5.5	10	30	M10 x 1.25
40	Up to 300	24	21	22	10	38	15	14	32 ^{0.039} _{0.039}	16	50	8	46.5	84.5	7	12	39	M14 x 1.5

Bore size (mm)	N	NA	NN	Q	QY	RR	S	U	Z	ZZ
20	15	24	M20 x 1.5	19.8	14	9	62	14	133	142
25	15	30	M26 x 1.5	22	14	9	62	14	137	146
32	15	34.5	M26 x 1.5	25.8	16	9	64	14	139	148
40	21.5	42.5	M32 x 2	29.8	16	11	88	18	177	188

Double Clevis Type (D)

CVM5D –

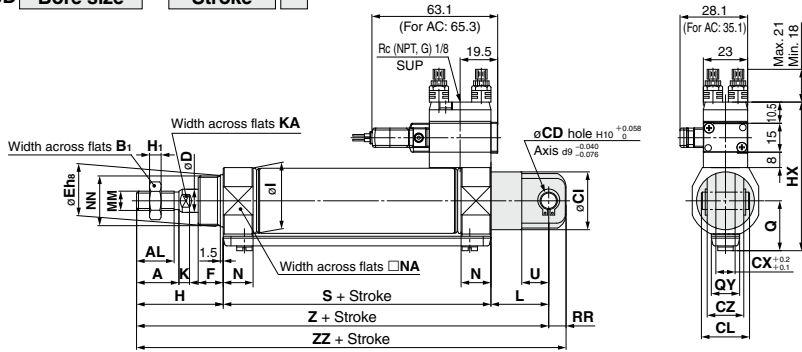

Bore size (mm)	Stroke range	A	AL	B ₁	CD	CI	CL	CX	CZ	D	Eh ₈	F	H	H ₁	HX	I	K	KA	L
20	Up to 300	18	15.5	13	9	24	25	10	19	8	20 ⁰ _{-0.033}	13	41	5	65.3	28	5	6	30
25	Up to 300	22	19.5	17	9	30	25	10	19	10	26 ⁰ _{-0.033}	13	45	6	70.5	33.5	5.5	8	30
32	Up to 300	22	19.5	17	9	30	25	10	19	12	26 ⁰ _{-0.033}	13	45	6	76.5	37.5	5.5	10	30
40	Up to 300	24	21	22	10	38	41.2	15	30	14	32 ⁰ _{-0.039}	16	50	8	84.5	46.5	7	12	39

Bore size (mm)	MM	N	NA	NN	Q	QY	RR	S	U	Z	ZZ
20	M8 x 1.25	15	24	M20 x 1.5	19.8	14	9	62	14	133	142
25	M10 x 1.25	15	30	M26 x 1.5	22	14	9	62	14	137	146
32	M10 x 1.25	15	34.5	M26 x 1.5	25.8	16	9	64	14	139	148
40	M14 x 1.5	21.5	42.5	M32 x 2	29.8	16	11	88	18	177	188

* Clevis pin and snap ring (cotter pin for ø40) are packaged together.

Rod Side Trunnion Type (U)

CVM5U –

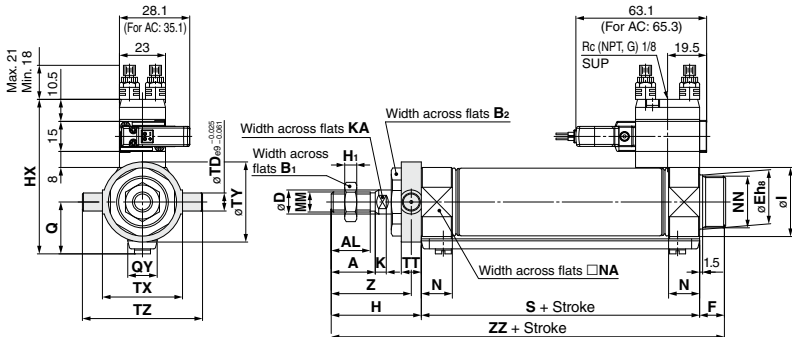

Bore size (mm)	Stroke range	A	AL	B ₁	B ₂	D	Eh ₈	F	H	H ₁	HX	I	K	KA	MM	N	NA	NN
20	Up to 300	18	15.5	13	26	8	20 ⁰ _{-0.033}	13	41	5	65.3	28	5	6	M8 x 1.25	15	24	M20 x 1.5
25	Up to 300	22	19.5	17	32	10	26 ⁰ _{-0.033}	13	45	6	70.5	33.5	5.5	8	M10 x 1.25	15	30	M26 x 1.5
32	Up to 300	22	19.5	17	32	12	26 ⁰ _{-0.033}	13	45	6	76.5	37.5	5.5	10	M10 x 1.25	15	34.5	M26 x 1.5
40	Up to 300	24	21	22	41	14	32 ⁰ _{-0.039}	16	50	8	84.5	46.5	7	12	M14 x 1.5	21.5	42.5	M32 x 2

Bore size (mm)	Q	QY	S	TD	TT	TX	TY	TZ	Z	ZZ
20	19.8	14	62	8	10	32	32	52	36	116
25	22	14	62	9	10	40	40	60	40	120
32	25.8	16	64	9	10	40	40	60	40	122
40	29.8	16	88	10	11	53	53	77	44.5	154

* Brackets are packaged together.

CVM5 Series

Head Side Trunnion Type (T)

CVM5T –

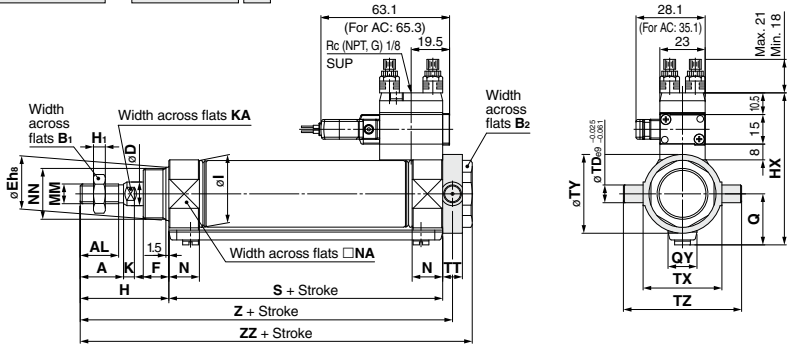

(mm)

Bore size (mm)	Stroke range	A	AL	B ₁	B ₂	D	Eh ₈	F	H	H ₁	HX	I	K	KA	MM	N	NA	NN
20	Up to 300	18	15.5	13	26	8	20 ⁰ _{-0.033}	13	41	5	65.3	28	5	6	M8 x 1.25	15	24	M20 x 1.5
25	Up to 300	22	19.5	17	32	10	26 ⁰ _{-0.033}	13	45	6	70.5	33.5	5.5	8	M10 x 1.25	15	30	M26 x 1.5
32	Up to 300	22	19.5	17	32	12	26 ⁰ _{-0.033}	13	45	6	76.5	37.5	5.5	10	M10 x 1.25	15	34.5	M26 x 1.5
40	Up to 300	24	21	22	41	14	32 ⁰ _{-0.039}	16	50	8	84.5	46.5	7	12	M14 x 1.5	21.5	42.5	M32 x 2

(mm)

Bore size (mm)	Q	QY	S	TD	TT	TX	TY	TZ	Z	ZZ
20	19.8	14	62	8	10	32	32	52	108	118
25	22	14	62	9	10	40	40	60	112	122
32	25.8	16	64	9	10	40	40	60	114	124
40	29.8	16	88	10	11	53	53	77	143.5	154

* Brackets are packaged together.

DIN Terminal

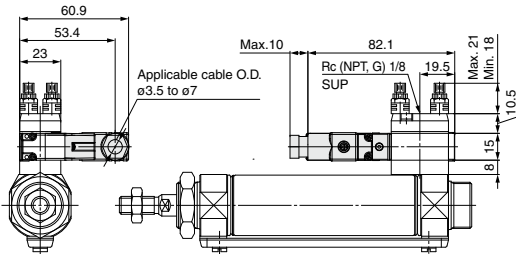

Double Solenoid

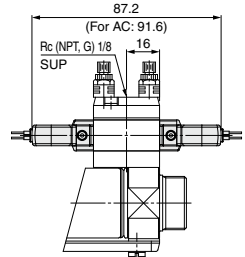

* For the mounting brackets of flange, single clevis, double clevis and head side trunnion type, the double solenoid may not be used depending on the mounting conditions.

CVM5K Series

A hexagon shaped rod that does not rotate.

Non-rotating accuracy

∅20, ∅25 — ±0.7°
∅32, ∅40 — ±0.5°

Can operate without lubrication.

Auto switches can also be mounted.

Can be installed with auto switches to facilitate the detection of the cylinder's stroke position.

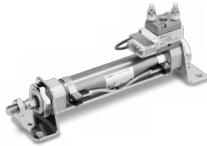

Symbol

Rubber bumper

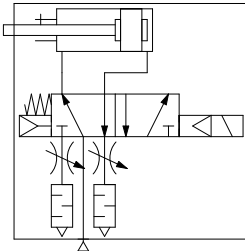

Made to Order Specifications
[Click here for details](#)

Symbol	Specifications
-XA□	Change of rod end shape

Refer to pages 1191 to 1193 for cylinders with auto switches.

- Proper auto switch mounting position (detection at stroke end) and mounting height
- Minimum auto switch mounting stroke
- Operating range
- Auto switch mounting bracket: Part no.

Specifications

Applicable bore size (mm)		20	25	32	40
Rod non-rotating accuracy		± 0.7°			± 0.5°
Fluid		Air			
Action		Double acting, Single rod			
Proof pressure		1.0 MPa			
Maximum operating pressure		0.7 MPa			
Minimum operating pressure		0.15 MPa			
Ambient and fluid temperature		-10 to 50°C (No freezing)			
Lubrication		Not required (Non-lube)			
Stroke length tolerance		+1.4 0			
Piston speed (mm/s)		50 to 700 *	50 to 650 *	50 to 590 *	50 to 420 *
Allowable kinetic energy		0.27 J	0.4 J	0.65 J	1.2 J
Port size	Screw-in type	Rc 1/8			
	Built-in One-touch fitting	O.D.: ∅6/I.D.: ∅4			
Mounting		Basic type, Axial foot type, Rod side flange type, Head side flange type, Single clevis type, Double clevis type, Head side trunnion type, Rod side trunnion type			

Note) The figures marked with "*" represent the values of the cylinder with the silencer type exhaust throttle valve removed. To operate the cylinder at these values, prevent dust from entering by installing an AN120-M5 silencer on the EXH port.

Solenoid Valve Specifications

Series		SYJ5□90 series	
Manual override		Non-locking push type, Push-turn locking slotted type, Push-turn locking lever type	
Pilot exhaust		Pilot valve individual exh. Type	
Impact/Vibration resistance (m/s ²) ^{Note 1)}		150/30	
Enclosure		Dustproof	
Electrical entry		Grommet (G), L plug connector (L), M plug connector (M), DIN terminal (D)	
		G, L, M	D
Coil rated voltage (V)	DC	24, 12, 6, 5, 3	
	AC 50/60 Hz	100, 110, 200, 220	
Allowable voltage		±10% of the rated voltage*	
Power consumption (W) ^{Note 2)}		DC 0.35 (With light: 0.4 (DIN terminal with light: 0.45))	
Apparent power (VA) ^{Note 2)}	AC	100 V	0.78 (With light: 0.81) 0.78 (With light: 0.87)
		110 V	0.86 (With light: 0.89) 0.86 (With light: 0.97)
		[115 V]	[0.94 (With light: 0.97)] [0.94 (With light: 1.07)]
		200 V	1.18 (With light: 1.22) 1.15 (With light: 1.30)
		220 V	1.30 (With light: 1.34) 1.27 (With light: 1.46)
[230 V]	[1.42 (With light: 1.46)] [1.39 (With light: 1.60)]		
Surge voltage suppressor		Diode (DIN terminal, Varistor when non-polar types)	
Indicator light		LED (Neon light when AC with DIN terminal)	

* Based on IEC60529

** In common between 110 VAC and 115 VAC, and between 220 VAC and 230 VAC.

** For 115 VAC and 230 VAC, the allowable voltage is -15% to +5% of rated voltage.

Note 1) Impact resistance: No malfunction occurred when it is tested in the axial direction and at the right angles to the main valve and armature in both energized and de-energized states every once for each condition. (Values at the initial period)

Vibration resistance: No malfunction occurred in a one-sweep test between 45 and 2000 Hz. The test was performed at both energized and de-energized states in the axial direction and at the right angles to the main valve and armature. (Values at the initial period)

Note 2) At the rated voltage.

Standard Stroke

Bore size (mm)	Standard stroke (mm) ^{Note)}
20	
25	25, 50, 75, 100, 125, 150
32	200, 250, 300
40	

Note) Other intermediate strokes can be manufactured upon receipt of order.

Although it is possible to make up to 1000 stroke length, when exceeding the standard stroke, there may be the case which cannot meet the specifications.

Rod Boot Material

Symbol	Rod boot material	Maximum ambient temperature
J	Nylon tarpaulin	70°C
K	Heat resistant tarpaulin	110°C *

* Maximum ambient temperature for the rod boot itself.

Valve Mounted Cylinder: Non-rotating Rod Type Double Acting **CVM5K Series**

Weight

Bore size (mm)		20	25	32	40
Basic weight	Basic type	0.22	0.29	0.36	0.64
	Axial foot type	0.27	0.45	0.52	0.91
	Flange type	0.28	0.38	0.45	0.76
	Single clevis type	0.26	0.33	0.40	0.73
	Double clevis type	0.27	0.35	0.41	0.77
	Trunnion type	0.26	0.36	0.42	0.74
Additional weight per each 50 mm of stroke		0.05	0.07	0.09	0.14
Option bracket	Single knuckle joint	0.06	0.06	0.06	0.23
	Double knuckle joint (with pin)	0.07	0.07	0.07	0.20

Calculation: (Example) **CVM5KL32-100-11G**

• Basic weight 0.52 (Axial foot type ø32) • Additional weight 0.09/50 st

• Cylinder stroke 100 (st)

$$0.52 + 0.09 \times 100/50 = 0.70 \text{ kg}$$

• Add 0.03 kg for the DIN terminal.

• Add 0.02 kg for the double solenoids.

• Add 0.03 kg for the closed center and exhaust center.

Mounting Bracket and Accessory

Mounting	Accessory			Standard equipment				Option			
	Mounting nut	Rod end nut	Clevis pin	Single knuckle joint	Double ⁽³⁾ knuckle joint	Pivot ⁽⁵⁾ bracket	Pivot ⁽⁶⁾ bracket pin				
Basic type	● (1 pc.)	●	—	●	●	—	—				
Axial foot type	● (2)	●	—	●	●	—	—				
Rod side flange type	● (1)	●	—	●	●	—	—				
Head side flange type	● (1)	●	—	●	●	—	—				
Single clevis type	— ⁽¹⁾	●	—	●	●	●	●				
Double clevis type ⁽³⁾	— ⁽¹⁾	●	● ⁽⁴⁾	●	●	—	—				
Head side trunnion type	● (1) ⁽²⁾	●	—	●	●	—	—				
Rod side trunnion type	● (1) ⁽²⁾	●	—	●	●	●	—				

Note 1) Mounting nut is not equipped with single clevis type and double clevis type.

Note 2) Trunnion nuts are equipped for head side trunnion and rod side trunnion.

Note 3) Pin and set ring are shipped together with double clevis and double knuckle joint.

Note 4) Retaining rings (cotter pins for ø40) are included in clevis pins.

Note 5) Pin and retaining ring are not included in pivot bracket.

Note 6) Retaining rings are included in pivot bracket pin.

Accessory (Option)

* Refer to page 1190 for part numbers and dimensions of the single knuckle joint, double knuckle joint, clevis pin, knuckle pin, rod end nut, mounting nut, and trunnion nut.

* Refer to page 255 of the CM2-Z series catalog for the part numbers and external dimensions of the pivot bracket and pivot bracket pin as well as for the dimensions when the cylinder is mounted.

⚠ Precautions

Be sure to read this before handling the products. Refer to page 9 for safety instructions, pages 10 to 19 for actuator and auto switch precautions, and 3/4/5 port solenoid valve precautions on the SMC website: <https://www.smcworld.com>

Precautions

⚠ Warning

1. **Do not rotate the cover.**

If a cover is rotated when installing a cylinder or screwing a fitting into the port, it is likely to damage the junction part with cover.

⚠ Caution

1. **Avoid using the air cylinder in such a way that rotational torque would be applied to the piston rod.**

If rotational torque is applied, the non-rotating guide will deform, causing a loss of non-rotating accuracy. Also, to screw a bracket or a nut onto the threaded portion at the end of the piston rod, make sure to retract the piston rod entirely, and place a wrench on the parallel sections of the rod that protrudes. To tighten, take precautions to prevent the tightening torque from being applied to the non-rotating guide.

Allowable rotational torque (N·m or less)	ø20	ø25	ø32	ø40
	0.2	0.25	0.25	0.44

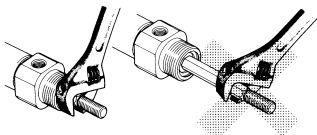

Disassembly/Replacement

⚠ Caution

1. **The rod seal replacement procedure is the same as that of the CM2□ standard type.**

After installing the rod seal, be sure to confirm that the piston rod and rod seal width across flats are not misaligned.

2. **Not able to disassemble.**

Since the cover and the cylinder tube are combined by crimping method, it is impossible to disassemble it. Therefore, the internal parts of a cylinder other than rod seal cannot be replaced at all.

3. **Do not touch the cylinder during operation.**

If the cylinder is operating at a high frequency, be aware that the cylinder tube surface could become very hot, creating the risk of burns.

4. **Conjoin the rod end part, so that rod boot might not be twisted.**

If a cylinder were installed with its rod boot being twisted, the rod boot could be damaged during operation.

Model Selection

⚠ Warning

1. **Confirm the specifications.**

Products in this catalog are designed to be used for compressed air systems. If not operated within the designated pressure or temperature, it may damage the products or cause malfunction. (Refer to specifications.)

2. **Energizing continuously for a long period of time**

When the valve is continuously energized for a long period of time, the performance may deteriorate, shorten the service life or affect peripheral equipment adversely since temperature rises when coils generate heat.

Basic Type (B): External Dimensions

CVM5KB —

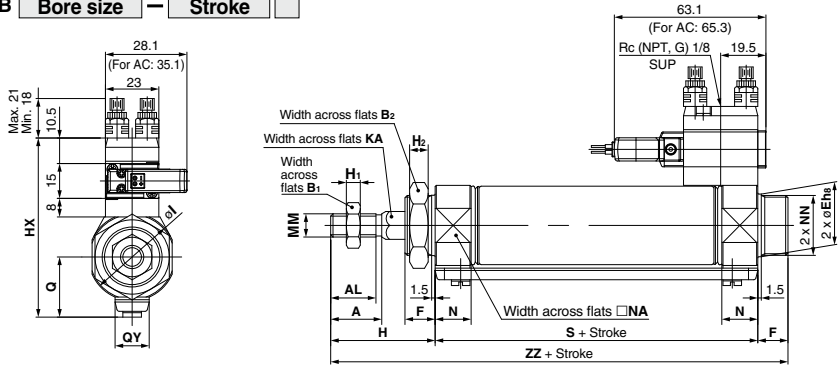

Built-in One-touch fitting

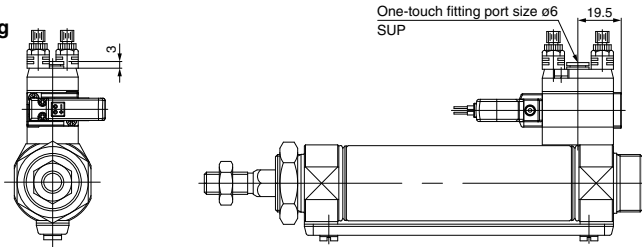

With rod boot

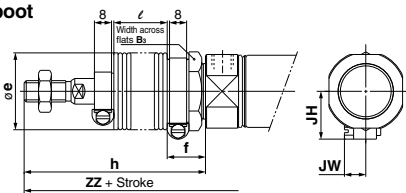

For DIN terminal and double solenoid, refer to page 1184.

Bore size (mm)	Stroke range	A	AL	B ₁	B ₂	Eh ₈	F	Q	QY	H	H ₁	H ₂	HX	I	KA	MM	N	NA	NN	S	ZZ
20	Up to 300	18	15.5	13	26	20 ⁰ _{-0.033}	13	19.8	14	41	5	8	65.3	28	8.2	M8 x 1.25	15	24	M20 x 1.5	62	116
25	Up to 300	22	19.5	17	32	26 ⁰ _{-0.033}	13	22	14	45	6	8	70.5	33.5	10.2	M10 x 1.25	15	30	M26 x 1.5	62	120
32	Up to 300	22	19.5	17	32	26 ⁰ _{-0.033}	13	25.8	16	45	6	8	76.5	37.5	12.2	M10 x 1.25	15	34.5	M26 x 1.5	64	122
40	Up to 300	24	21	22	41	32 ⁰ _{-0.039}	16	29.8	16	50	8	10	84.5	46.5	14.2	M14 x 1.5	21.5	42.5	M32 x 2	88	154

With Rod Boot

Bore size (mm)	B _s	e	f	h					l					JH	JW
				1 to 50	51 to 100	101 to 150	151 to 200	201 to 300	1 to 50	51 to 100	101 to 150	151 to 200	201 to 300		
20	30	36	18	68	81	93	106	131	12.5	25	37.5	50	75	23.5	10.5
25	32	36	18	72	85	97	110	135	12.5	25	37.5	50	75	23.5	10.5
32	32	36	18	72	85	97	110	135	12.5	25	37.5	50	75	23.5	10.5
40	41	46	20	77	90	102	115	140	12.5	25	37.5	50	75	27	10.5

(mm)

Bore size (mm)	ZZ				
	1 to 50	51 to 100	101 to 150	151 to 200	201 to 300
20	143	156	168	181	206
25	147	160	172	185	210
32	149	162	174	187	212
40	181	194	206	219	244

CVM5 Series

Accessory dimensions

Single Knuckle Joint Mounting (mm)

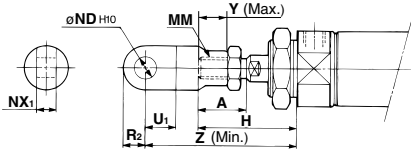

Bore size	A	H	MM	ND H10	NX1	U1	R2	Y	Z
20	18	41	M8 x 1.25	9 ^{+0.058/0}	9 ^{+0.1/-0.2}	14	10	11	66
25, 32	22	45	M10 x 1.25	9 ^{+0.058/0}	9 ^{+0.1/-0.2}	14	10	14	69
40	24	50	M14 x 1.5	12 ^{+0.070/0}	16 ^{+0.1/-0.3}	20	14	13	92

Double Knuckle Joint Mounting (mm)

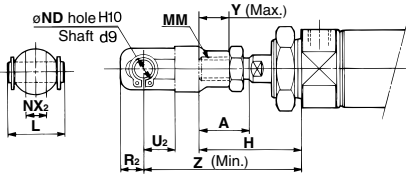

Bore size	A	H	L	MM	ND	NX2	R2	U2	Y	Z
20	18	41	25	M8 x 1.25	9	9 ^{+0.2/-0.1}	10	14	11	66
25, 32	22	45	25	M10 x 1.25	9	9 ^{+0.2/-0.1}	10	14	14	69
40	24	50	49.7	M14 x 1.5	12	16 ^{+0.3/-0.1}	13	25	13	92

Double Clevis Pin/Material: Carbon steel (mm)

Bore size: $\phi 20, \phi 25, \phi 32$
CDP-1

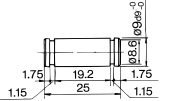

Retaining ring: Type C9 for shaft
* Retaining rings (cotter pins for $\phi 40$) are included.

Bore size: $\phi 40$
CDP-2

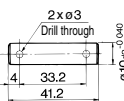

Cotter pins used $\phi 3 \times 18 \ell$

Single Knuckle Joint (mm)

I-020B, 032B Material: Rolled steel I-040B Material: Free cutting sulfur steel

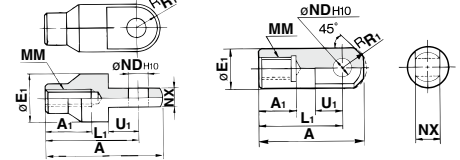

Part no.	Applicable bore size	A	A1	E1	L1	MM	ND H10	NX	R1	U1
I-020B	20	46	16	20	36	M8 x 1.25	9 ^{+0.058/0}	9 ^{+0.1/-0.2}	10	14
I-032B	25, 32	48	18	20	38	M10 x 1.25	9 ^{+0.058/0}	9 ^{+0.1/-0.2}	10	14
I-040B	40	69	22	24	55	M14 x 1.5	12 ^{+0.070/0}	16 ^{+0.1/-0.3}	15.5	20

Double Knuckle Joint (mm)

Y-020B, Y-032B Material: Rolled steel Y-040B Material: Cast iron

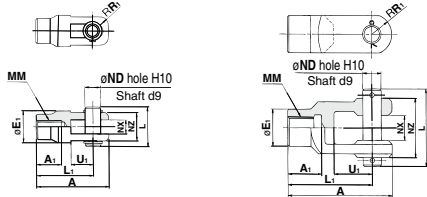

Part no.	Applicable cylinder bore size	A	A1	E1	L	L1	MM	ND
Y-020B	20	46	16	20	25	36	M8 x 1.25	9
Y-032B	25, 32	48	18	20	25	38	M10 x 1.25	9
Y-040B	40	68	22	24	49.7	55	M14 x 1.5	12

Part no.	NX	NZ	R1	U1	Applicable pin pair no.	Retaining ring size
Y-020B	9 ^{+0.2/-0.1}	18	5	14	CDP-1	Type C9 for shaft
Y-032B	9 ^{+0.2/-0.1}	18	5	14	CDP-1	Type C9 for shaft
Y-040B	16 ^{+0.3/-0.1}	38	13	25	CDP-3	$\phi 3 \times 18 \ell$

* Knuckle pins and retaining rings (cotter pins for $\phi 40$) are included.

Double Knuckle Pin/Material: Carbon steel (mm)

Bore size: $\phi 20, \phi 25, \phi 32$
CDP-1

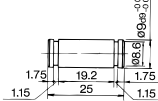

Retaining ring: Type C9 for shaft
* Retaining rings (cotter pins for $\phi 40$) are included.

Bore size: $\phi 40$
CDP-3

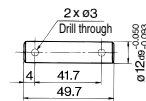

Cotter pins used $\phi 3 \times 18 \ell$

Rod End Nut (mm)

Material: Carbon steel

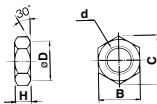

Part no.	Applicable bore size	B	C	D	d	H
NT-02	20	13	15.0	12.5	M8 x 1.25	5
NT-03	25, 32	17	19.6	16.5	M10 x 1.25	6
NT-04	40	22	25.4	21.0	M14 x 1.5	8

Mounting Nut (mm)

Material: Carbon steel

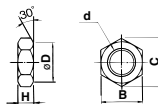

Part no.	Applicable bore size	B	C	D	d	H
SN-020B	20	26	30	25.5	M20 x 1.5	8
SN-032B	25, 32	32	37	31.5	M26 x 1.5	8
SN-040B	40	41	47.3	40.5	M32 x 2.0	10

Trunnion Nut (mm)

Material: Carbon steel

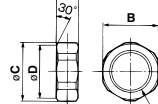

Part no.	Applicable bore size	B	C	D	d	H
TN-020B	20	26	28	25.5	M20 x 1.5	10
TN-032B	25, 32	32	34	31.5	M26 x 1.5	10
TN-040B	40	41	45	40.5	M32 x 2	10

Auto Switch Mounting 1

Auto Switch Proper Mounting Position (Detection at Stroke End) and Mounting Height

Reed auto switch

D-A9□

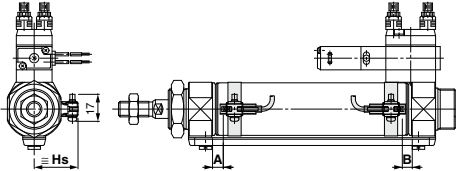

A and B are the dimensions from the end of the head cover/rod cover to the end of the auto switch.

D-C7/C8

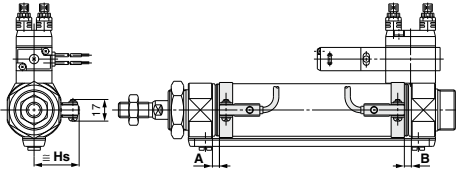

D-B5/B6/B59W

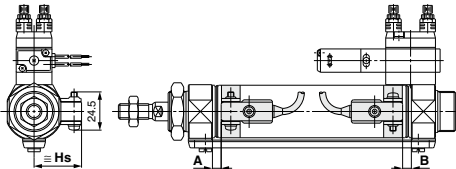

D-C73C/C80C

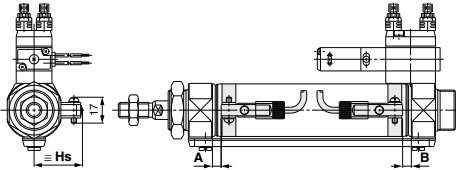

Solid state auto switch

D-M9□/D-M9□W

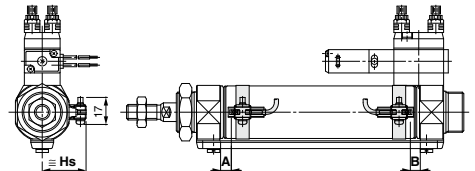

D-H7□/H7□W/H7NF

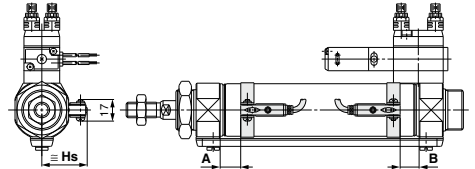

D-G5NT

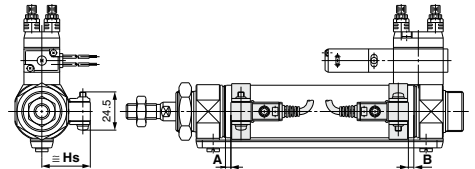

D-H7C

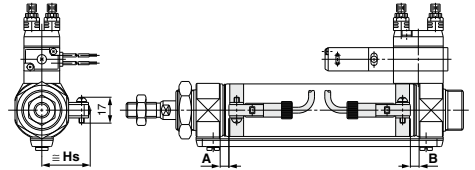

Auto Switch Proper Mounting Position (Detection at Stroke End) and Mounting Height

Auto Switch Proper Mounting Position

(mm)

Auto switch model	D-A9□(V)		D-M9□(V) D-M9□W(V) D-A9□A(V)		D-B5□ D-B64		D-C7□ D-C80 D-C73C D-C80C		D-B59W		D-H7□ D-H7C D-H7□W D-H7NF		D-G5NT	
	A	B	A	B	A	B	A	B	A	B	A	B	A	B
Bore size (mm) 20	6.5	5.5	10.5	9.5	1	0	7	6	4	3	6	5	2.5	1.5
25	6.5	5.5	10.5	9.5	1	0	7	6	4	3	6	5	2.5	1.5
32	7.5	6.5	11.5	10.5	2	1	8	7	5	4	7	6	3.5	2.5
40	13.5	11.5	17.5	15.5	7	6	13	12	10	9	12	11	8.5	7.5

Note) Adjust the auto switch after confirming the operating conditions in the actual setting.

Auto Switch Mounting Height

(mm)

Auto switch model	D-A9□(V) D-M9□(V) D-M9□W(V) D-M9□A(V)		D-B5□ D-B64 D-B59W D-G5NT D-H7C		D-C7□ D-C80 D-H7□ D-H7□W D-H7NF		D-C73C D-C80C
	Hs	Hs	Hs	Hs	Hs	Hs	
Bore size (mm) 20	23	25.5	25.5	22.5	25	25	
25	25.5	28	28	25	27.5	27.5	
32	29	31.5	31.5	28.5	31	31	
40	33	35.5	35.5	32.5	35	35	

Auto Switch Mounting 2

Minimum Auto Switch Mounting Stroke

Auto switch model	No. of auto switch mounted				n: No. of auto switches (mm)	
	1	2		n		
		Different surfaces	Same surface	Different surfaces	Same surface	
D-A9□ D-M9□ D-M9□W	10	15 ^{Note 1)}	45 ^{Note 1)}	$15 + 45 \frac{(n-2)}{2}$ (n = 2, 4, 6...) ^{Note 2)}	$45 + 45 (n-2)$ (n = 2, 3, 4, 5...)	
D-M9□V	5	20	35	$20 + 35 \frac{(n-2)}{2}$ (n = 2, 4, 6...) ^{Note 2)}	$35 + 35 (n-2)$ (n = 2, 3, 4, 5...)	
D-A9□V	5	15	25	$15 + 35 \frac{(n-2)}{2}$ (n = 2, 4, 6...) ^{Note 2)}	$25 + 35 (n-2)$ (n = 2, 3, 4, 5...)	
D-M9□WV D-M9□AV	10	20	35	$20 + 35 \frac{(n-2)}{2}$ (n = 2, 4, 6...) ^{Note 2)}	$35 + 35 (n-2)$ (n = 2, 3, 4, 5...)	
D-C7□ D-C80	10	15	50	$15 + 45 \frac{(n-2)}{2}$ (n = 2, 4, 6...) ^{Note 2)}	$50 + 45 (n-2)$ (n = 2, 3, 4, 5...)	
D-H7□ D-H7□W D-H7NF	10	15	60	$15 + 45 \frac{(n-2)}{2}$ (n = 2, 4, 6...) ^{Note 2)}	$60 + 45 (n-2)$ (n = 2, 3, 4, 5...)	
D-C73C D-C80C D-H7C	10	15	65	$15 + 50 \frac{(n-2)}{2}$ (n = 2, 4, 6...) ^{Note 2)}	$65 + 50 (n-2)$ (n = 2, 3, 4, 5...)	
D-B5□/B64 D-G5NT	10	15	75	$15 + 50 \frac{(n-2)}{2}$ (n = 2, 4, 6...) ^{Note 2)}	$75 + 55 (n-2)$ (n = 2, 3, 4, 5...)	
D-B59W	15	20	75	$20 + 50 \frac{(n-2)}{2}$ (n = 2, 4, 6...) ^{Note 2)}	$75 + 55 (n-2)$ (n = 2, 3, 4, 5...)	

Note 2) When "n" is an odd number, an even number that is one larger than this odd number is used for the calculation.

Note 1) Auto switch mounting (The adjustment as shown in the figures below is required with the following stroke ranges.)

Auto switch model	With 2 auto switches	
	Different surfaces ^{Note 1)}	Same surface ^{Note 1)}
	<p>The proper auto switch mounting position is 6 mm inward from the switch holder edge.</p>	<p>The auto switch is mounted by slightly displacing it in a direction (cylinder tube circumferential exterior) so that the auto switch and lead wire do not interfere with each other.</p>
D-A93	—	45 to less than 50 stroke
D-M9□ D-M9□W	15 to less than 20 stroke	45 to less than 55 stroke

Operating Range

Auto switch model	Bore size (mm)			
	20	25	32	40
D-A9□(V)	6	6	6	6
D-M9□(V)/M9□W(V) D-M9□A(V)	3.5	3	3.5	3
D-C7□/C80 D-C73C/C80C	7	8	8	8
D-B5□/B64	8	8	9	9
D-B59W	12	12	13	13
D-H7□/H7□W D-G5NT/H7NF	4	4	4.5	5
D-H7C	7	8.5	9	10

* Since the operating range is provided as a guideline including hysteresis, it cannot be guaranteed (assuming approximately ±30% dispersion). It may vary substantially depending on an ambient environment.

Auto Switch Mounting Bracket: Part No.

Auto switch mounting	Bore size (mm)			
	φ20	φ25	φ32	φ40
D-M9□(V) D-M9□W(V) D-A9□(V)	Note 1) BM5-020 (A set of a, b, c, d)	Note 1) BM5-025 (A set of a, b, c, d)	Note 1) BM5-032 (A set of a, b, c, d)	Note 1) BM5-040 (A set of a, b, c, d)
D-M9□A(V) (Note 2)	BM5-020S (A set of b, c, e, f)	BM5-025S (A set of b, c, e, f)	BM5-032S (A set of b, c, e, f)	BM5-040S (A set of b, c, e, f)
D-H7□ D-H7□W D-H7NF D-C7□/C80 D-C73C/C80C	BM2-020A (A set of c and d)	BM2-025A (A set of c and d)	BM2-032A (A set of c and d)	BM2-040A (A set of c and d)
D-B5□/B64 D-B59W D-G5NT	BA2-020 (A set of c and d)	BA2-025 (A set of c and d)	BA2-032 (A set of c and d)	BA2-040 (A set of c and d)

Note 1) As the switch bracket is made of polyamide, its performance may be affected by chemicals such as alcohol, chloroform, methylamines, hydrochloric acid, and sulfuric acid, so it cannot be used in environments where these chemicals come into contact with the product.

Note 2) When mounting a D-M9□A(V) type auto switch, if the switch bracket is mounted on the indicator light, it may damage the auto switch. Therefore, be sure to avoid mounting the switch bracket on the indicator light.

[Mounting screw set made of stainless steel]

The following set of mounting screws made of stainless steel is available. Use it in accordance with the operating environment. (Please order the auto switch mounting bracket separately, since it is not included.)

BBA4: For D-C7/C8/H7 types

Note) Refer to page 1440 for the details of BBA4.

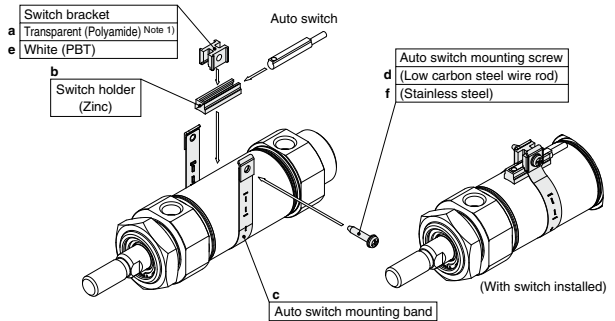

* Band (c) is mounted so that the projected part is on the internal side (contact side with the tube).

Besides the models listed in How to Order, the following auto switches are applicable. Refer to pages 1341 to 1435 for detailed specifications.

Auto switch type	Part no.	Electrical entry (Fetching direction)	Features
Reed	D-B53, C73, C76	Grommet (In-let)	—
	D-C80		Without indicator light
Solid state	D-H7A1, H7A2, H7B		—
	D-H7NW, H7PW, H7BW		Diagnostic indication (2-color)
	D-G5NT	With timer	

* For solid state auto switches, auto switches with a pre-wired connector are also available. Refer to pages 1410 and 1411 for details.

* Normally closed (NC = b contact) solid state auto switches (D-M9□E(V)) are also available. Refer to page 1360 for details.

Valve Mounted Cylinder Single Acting, Spring Return/Extend **CVM3 Series**

An auto switch cylinder with the switch installed can also be manufactured.

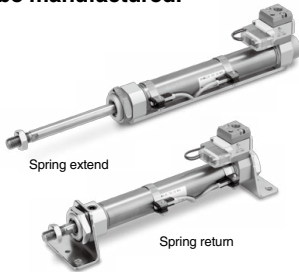

Symbol
Rubber bumper

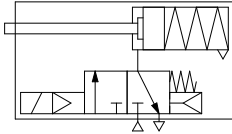
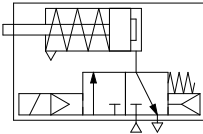

Made to Order Specifications
[Click here for details](#)

Symbol	Specifications
-XA□	Change of rod end shape

Refer to pages 1212 to 1215 for cylinders with auto switches.

- Proper auto switch mounting position (detection at stroke end) and mounting height
- Minimum auto switch mounting stroke
- Operating range
- Auto switch mounting bracket: Part no.

Specifications

Applicable bore size (mm)		20	25	32	40
Action		Single acting, Spring return/Spring extend			
Fluid		Air			
Cushion		Rubber bumper			
Proof pressure		1.0 MPa			
Maximum operating pressure		0.7 MPa			
Minimum operating pressure		0.18 MPa Spring return	0.23 MPa Spring extend		
Ambient and fluid temperature		-10 to 50°C (No freezing)			
Lubrication		Not required (Non-lube)			
Stroke length tolerance		+1.4 0			
Piping	Screw-in type	Rc 1/8			
	Built-in One-touch fitting	O.D.: ø6/I.D.: ø4			
Manual override		Non locking (Standard)			
Allowable kinetic energy		0.27 J	0.4 J	0.65 J	1.2 J
Mounting		Basic type, Axial foot type, Rod side flange type, Head side flange type, Single clevis type, Double clevis type, Head side trunnion type, Rod side trunnion type			

Solenoid Valve Specifications

Series		SYJ519	
Manual override		Non-locking push type, Push-turn locking slotted type, Push-turn locking lever type	
Pilot exhaust		Pilot valve individual exh. Type	
Impact/Vibration resistance (m/s²)^{Note 1}		150/30	
Enclosure		Dustproof	
Electrical entry		Grommet (G), L plug connector (L), M plug connector (M), DIN terminal (D)	
Coil rated voltage (V)	DC	24, 12, 6, 5, 3	D
	AC 50/60 Hz	100, 110, 200, 220	
Allowable voltage		±10% of the rated voltage*	
Power consumption (W)^{Note 2}		DC 0.35 (With light: 0.4 (DIN terminal with light: 0.45))	
Apparent power (VA)^{Note 2}	AC	100 V	0.78 (With light: 0.81) 0.78 (With light: 0.87)
		110 V	0.86 (With light: 0.89) 0.86 (With light: 0.97)
		[115 V]	[0.94 (With light: 0.97)] [0.94 (With light: 1.07)]
		200 V	1.18 (With light: 1.22) 1.15 (With light: 1.30)
		220 V	1.30 (With light: 1.34) 1.27 (With light: 1.46)
	[230 V]	[1.42 (With light: 1.46)] [1.39 (With light: 1.60)]	
Surge voltage suppressor		Diode (DIN terminal, Varistor when non-polar types)	
Indicator light		LED (Neon light when AC with DIN terminal)	

* Based on IEC60529

* In common between 110 VAC and 115 VAC, and between 220 VAC and 230 VAC.

* For 115 VAC and 230 VAC, the allowable voltage is -15% to +5% of rated voltage.

Note 1) Impact resistance: No malfunction occurred when it is tested in the axial direction and at the right angles to the main valve and armature in both energized and de-energized states every once on each condition. (Values at the initial period)

Vibration resistance: No malfunction occurred in a one-sweep test between 45 and 2000 Hz. The test was performed at both energized and de-energized states in the axial direction and at the right angles to the main valve and armature. (Values at the initial period)

Note 2) At the rated voltage.

Standard Stroke

Bore size (mm)	Standard stroke (mm) ^{Note}
20	25, 50, 75, 100, 125, 150 *
25	25, 50, 75, 100, 125, 150 *
32	25, 50, 75, 100, 125, 150, 200 *
40	25, 50, 75, 100, 125, 150, 200, 250 *

Note 1) Intermediate stroke except mentioned above is produced upon receipt of order.

Note 2) Strokes marked with "*" are the maximum strokes which are available.

Theoretical Output

Refer to the Technical Data (Theoretical Output 1) in the **Web Catalog**.

Spring Reaction Force

Refer to the Technical Data (Table 2: Spring Reaction Force) in the **Web Catalog**.

CVM3 Series

Mounting Bracket and Accessory

Accessory	Standard equipment			Option			
	Mounting nut	Rod end nut	Clevis pin	Single knuckle joint	Double knuckle joint ⁽³⁾	Pivot bracket ⁽⁵⁾	Pivot bracket pin ⁽⁶⁾
Mounting							
Basic type	● (1 pc.)	●	—	●	●		
Axial foot type	● (2)	●	—	●	●		
Rod side flange type	● (1)	●	—	●	●		
Head side flange type	● (1)	●	—	●	●		
Single clevis type	— ⁽¹⁾	●	—	●	●	●	●
Double clevis type ⁽³⁾	— ⁽¹⁾	●	● ⁽⁴⁾	●	●	—	—
Head side trunnion type	● (1) ⁽²⁾	●	—	●	●		
Rod side trunnion type	● (1) ⁽²⁾	●	—	●	●	●	—

- Note 1) Mounting nut is not equipped with single clevis type and double clevis type.
 Note 2) Trunnion nuts are equipped for head side trunnion and rod side trunnion.
 Note 3) Pin and retaining ring are shipped together with double clevis and double knuckle joint.
 Note 4) Retaining rings (cotter pins for ø40) are included in clevis pins.
 Note 5) Pin and retaining ring are not included in pivot bracket.
 Note 6) Retaining rings are included in pivot bracket pin.

Weight

Spring Return(): Denotes Spring Extend.

Bore size (mm)		20	25	32	40
Basic weight	25 stroke	0.27 (0.27)	0.37 (0.37)	0.49 (0.48)	0.84 (0.83)
	50 stroke	0.29 (0.29)	0.40 (0.40)	0.53 (0.53)	0.91 (0.90)
	75 stroke	0.34 (0.34)	0.49 (0.48)	0.65 (0.63)	1.10 (1.06)
	100 stroke	0.36 (0.36)	0.52 (0.51)	0.70 (0.67)	1.16 (1.13)
	125 stroke	0.42 (0.41)	0.61 (0.58)	0.83 (0.79)	1.36 (1.30)
	150 stroke	0.44 (0.43)	0.64 (0.61)	0.87 (0.83)	1.43 (1.37)
	200 stroke	—	—	1.03 (0.99)	1.68 (1.60)
	250 stroke	—	—	—	1.94 (1.82)
Mounting bracket weight	Axial foot	0.15 (0.15)	0.16 (0.16)	0.16 (0.16)	0.27 (0.27)
	Flange	0.06 (0.06)	0.09 (0.09)	0.09 (0.09)	0.12 (0.12)
	Single clevis	0.04 (0.04)	0.04 (0.04)	0.04 (0.04)	0.09 (0.09)
	Double clevis	0.05 (0.05)	0.06 (0.06)	0.06 (0.06)	0.13 (0.13)
Option bracket	Trunnion	0.04 (0.04)	0.07 (0.07)	0.07 (0.07)	0.10 (0.10)
	Single knuckle joint	0.06 (0.06)	0.06 (0.06)	0.06 (0.06)	0.23 (0.23)
	Double knuckle (With pin)	0.07 (0.07)	0.07 (0.07)	0.07 (0.07)	0.20 (0.20)

Calculation
 (Example) **CVM3L32-100S-1G**
 (ø32, 100 stroke, Spring return)
 • Basic weight:.....0.70 (kg)
 • Weight of brackets:.....0.16 (kg)
 0.70 + 0.16 = 0.86 kg
 • Add 0.03 kg for the DIN terminal.

Accessory Bracket

Further information on accessories are the same specifications as these of the standard double acting single rod. Refer to page 1190.

Manual Operation

Manual operation is possible by pushing the manual button indicated with the arrow.

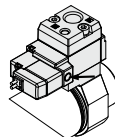

⚠️ Precautions

Be sure to read this before handling the products. Refer to page 9 for safety instructions, pages 10 to 19 for actuator and I/O switch precautions, and 3/4/5 port solenoid valve precautions on the SMC web site: <https://www.smcworld.com>

Operating Precautions

⚠️ Warning

1. Do not rotate the cover.

If a cover is rotated when installing a cylinder or screwing a fitting into port, it is likely to damage the junction part with cover.

⚠️ Caution

1. Not able to disassemble.

Cover and cylinder tube are connected to each other by caulking method, thus making it impossible to disassemble. Therefore, internal parts of a cylinder other than rod seal are not replaceable.

2. Use caution to the popping of a retaining ring.

When replacing rod seals and removing and mounting a retaining ring, use a proper tool (retaining ring plier: tool for installing type C retaining ring). Even if a proper tool is used, it is likely to inflict damage to a human body or peripheral equipment, as a retaining ring may be flown out of the tip of a plier. Be much careful with the popping of a retaining ring. Besides, be certain that a retaining ring is placed firmly into the groove of rod cover before supplying air at the time of installation.

⚠️ Caution

3. Do not touch the cylinder during operation.

Use caution when handling a cylinder, which is running at a high speed and a high frequency, because the surface of a cylinder tube could get so hot enough as to cause you get burned.

4. One-touch fitting cannot be replaced.

One-touch fitting is press-fit into the cover, thus cannot be replaced.

Model Selection

⚠️ Warning

1. Confirm the specifications.

Products in this catalog are designed to be used for compressed air systems (including vacuum). If not operated within the designated pressure or temperature, it may damage the products or cause malfunction. (Refer to specifications.)

2. Energizing continuously for a long period of time

When the valve is continuously energized for a long period of time, the performance may deteriorate, shorten the service life or affect peripheral equipment adversely since temperature rises when coils generate heat.

Built-in One-touch Fitting

CVM3 **Mounting type** **Bore size** F — For “How to Order”, refer to page 1194.
 ↓ Built-in One-touch fitting

One-touch fittings are installed on cylinders.

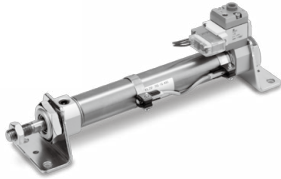

For dimensions of each mounting bracket, refer to pages 1200 to 1206.

Specifications

Action	Single acting, Spring return		Single acting, Spring extend	
Bore size (mm)	ø20, ø25, ø32, ø40			
Max. operating pressure	0.7 MPa			
Min. operating pressure	0.18 MPa		0.23 MPa	
Cushion	Rubber bumper			
Piping	Built-in One-touch fitting			
Piston speed (mm/s)	ø20	ø25	ø32	ø40
	50 to 700	50 to 650	50 to 590	50 to 420
Port size (Tube bore size)	O.D.: ø6/I.D.: ø4			
Applicable bore size	Can be used for either nylon, soft nylon or polyurethane tube.			
Mounting	Basic type, Axial foot type, Rod side flange type, Head side flange type, Single clevis type, Double clevis type, Head side trunnion type, Rod side trunnion type			

Mounting Bracket Part No.

Bore size (mm)	20	25	32	40
Axial foot *	CM-L020B	CM-L032B	CM-L040B	CM-L040B
Flange	CM-F020B	CM-F032B	CM-F040B	CM-F040B
Single clevis	CM-C020B	CM-C032B	CM-C040B	CM-C040B
Double clevis **	CM-D020B	CM-D032B	CM-D040B	CM-D040B
Trunnion (with nut)	CM-T020B	CM-T032B	CM-T040B	CM-T040B

* Two foot brackets and a mounting nut are attached.

When ordering the foot bracket, order 2 pcs. per cylinder.

** Clevis pin and retaining ring (cotter pin for ø40) are packaged together.

CVM3 Series

Construction

Spring return

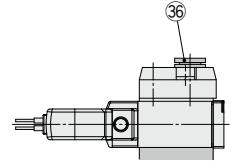
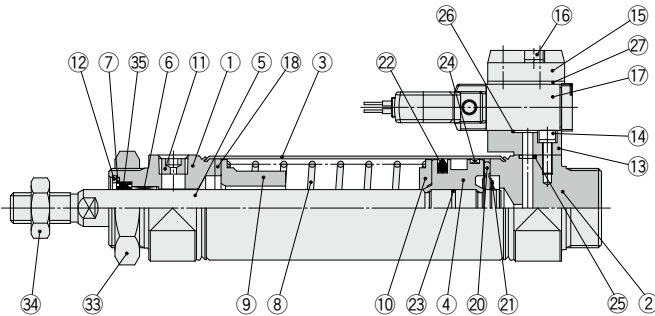

Built-in One-touch fitting

Spring extend

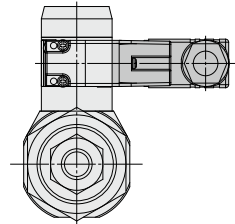
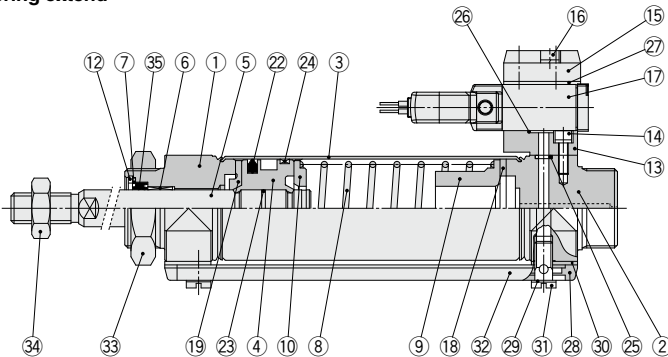

DIN terminal

Component Parts

No.	Description	Material	Note
1	Rod cover	Aluminum alloy	Anodized
2	Head cover	Aluminum alloy	Anodized
3	Cylinder tube	Stainless steel	
4	Piston	Aluminum alloy	
5	Piston rod	Carbon steel	Hard chromium electroplated
6	Bushing	Bearing alloy	
7	Seal retainer	Stainless steel	
8	Return spring	Steel wire	Zinc chromated
9	Spring guide	Aluminum alloy	
10	Spring seat	Aluminum alloy	
11	Plug with fixed orifice	Alloy steel	Black dyed
12	Retaining ring	Carbon steel	Phosphate coated
13	Sub-plate	Aluminum alloy	Metallic painted
14	Hex. socket head cap screw with spring washer	Stainless steel	
15	Plate	Alloy	Metallic painted
16	Hex. socket head cap screw with spring washer	Stainless steel	
17	Solenoid valve	—	Refer to "How to order" below.*
18	Bumper	Urethane	
19	Bumper A	Urethane	

* How to order solenoid valves

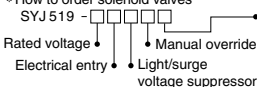

Nil	Valves other than those below All valves with a DC rated voltage
-Q	Valves with an AC rated voltage (DIN terminal only)

Component Parts

No.	Description	Material	Note
20	Bumper B	Urethane	
21	Retaining ring	Stainless steel	
22	Piston seal	NBR	
23	Piston gasket	NBR	
24	Wear ring	Resin	
25	Head cover gasket	NBR	
26	Sub-plate gasket	NBR	
27	Gasket	NBR	
28	Pipe gasket	Urethane rubber	
29	Gasket	Resin	
30	Spacer gasket	Resin	
31	Stud	Brass	Electroless nickel plated
32	Pipe	Aluminum alloy	
33	Mounting nut	Carbon steel	Nickel plated
34	Rod end nut	Carbon steel	Zinc chromated
36	One-touch fitting	—	Port size: ø6

Replacement Parts/Seal Kit

No.	Description	Material	Part no.			
			20	25	32	40
35	Rod seal	NBR	CM220-PS	CM225-PS	CM232-PS	CM240-PS

* Since the seal kit does not include a grease pack, order it separately.

Grease pack part no.: GR-S-010 (10g)

Valve Mounted Cylinder **CVM3 Series**

Single Acting, Spring Return/Extend

Basic Type (B)

Single acting, Spring return: CVM3B Bore size — Stroke S

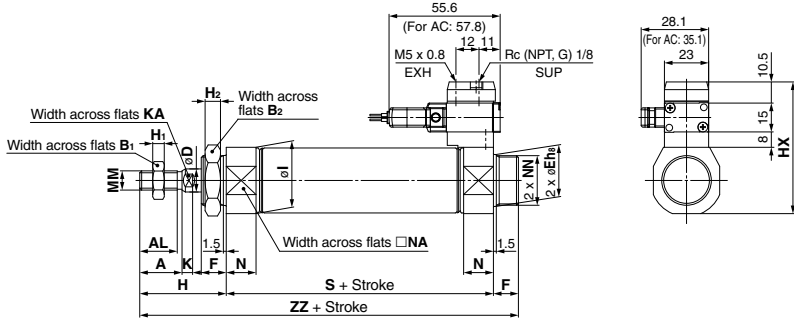

Single acting, Spring extend: CVM3B Bore size — Stroke T

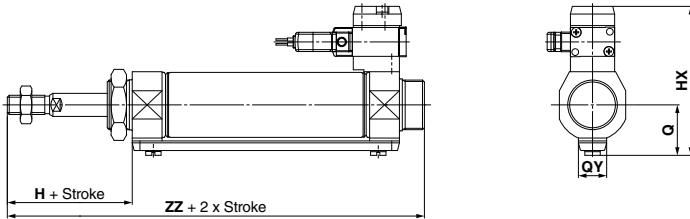

Built-in One-touch fitting

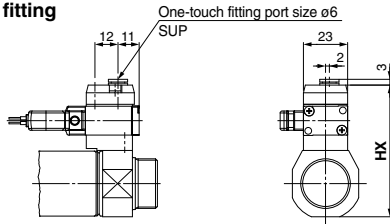

Bore size (mm)	A	AL	B ₁	B ₂	D	Eh ₈	F	H	H ₁	H ₂	HX	I	K	KA	MM	N	NA	NN
20	18	15.5	13	26	8	20 ⁰ _{-0.033}	13	41	5	8	57.5	28	5	6	M8 x 1.25	15	24	M20 x 1.5
25	22	19.5	17	32	10	26 ⁰ _{-0.039}	13	45	6	8	63.5	33.5	5.5	8	M10 x 1.25	15	30	M26 x 1.5
32	22	19.5	17	32	12	26 ⁰ _{-0.033}	13	45	6	8	68	37.5	5.5	10	M10 x 1.25	15	34.5	M26 x 1.5
40	24	21	22	41	14	32 ⁰ _{-0.039}	16	50	8	10	76	46.5	7	12	M14 x 1.5	21.5	42.5	M32 x 2

Dimensions by Stroke

Bore size (mm)	1 to 50		51 to 100		101 to 150		151 to 200		201 to 250	
	S	ZZ	S	ZZ	S	ZZ	S	ZZ	S	ZZ
20	87	141	112	166	137	191	—	—	—	—
25	87	145	112	170	137	195	—	—	—	—
32	89	147	114	172	139	197	164	222	—	—
40	113	179	138	204	163	229	188	254	213	279

Single Acting/Spring Extend (mm)

Bore size (mm)	HX	Q	QY
20	65.3	19.8	14
25	70.5	22	14
32	76.5	25.8	16
40	84.5	29.8	16

CVM3 Series

Axial Foot Type (L)

Single acting, Spring return: CVM3L — S

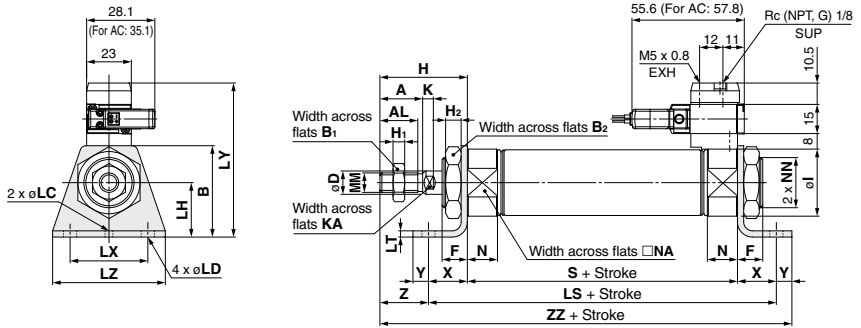

Single acting, Spring extend: CVM3L — T

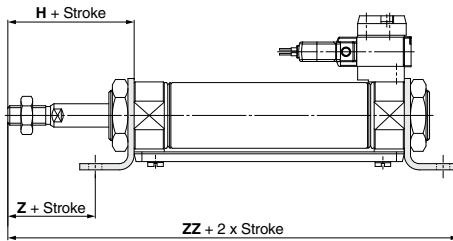

Bore size (mm)	A	AL	B	B ₁	B ₂	D	F	H	H ₁	H ₂	I	K	KA	LC	LD	LH	LT	LX	LY	LZ	MM	N	NA
20	18	15.5	40	13	26	8	13	41	5	8	28	5	6	4	6.8	25	3.2	40	70.5	55	M8 x 1.25	15	24
25	22	19.5	47	17	32	10	13	45	6	8	33.5	5.5	8	4	6.8	28	3.2	40	76.5	55	M10 x 1.25	15	30
32	22	19.5	47	17	32	12	13	45	6	8	37.5	5.5	10	4	6.8	28	3.2	40	78.8	55	M10 x 1.25	15	34.5
40	24	21	54	22	41	14	16	50	8	10	46.5	7	12	4	7	30	3.2	55	84.8	75	M14 x 1.5	21.5	42.5

(mm)				
Bore size (mm)	NN	X	Y	Z
20	M20 x 1.5	20	8	21
25	M26 x 1.5	20	8	25
32	M26 x 1.5	20	8	25
40	M32 x 2	23	10	27

Dimensions by Stroke

Bore size (mm)	Stroke											
	1 to 50	51 to 100	101 to 150	151 to 200	201 to 250							
Symbol	S	LS	ZZ	S	LS	ZZ	S	LS	ZZ	S	LS	ZZ
20	87	127	156	112	152	181	137	177	206	—	—	—
25	87	127	160	112	152	185	137	177	210	—	—	—
32	89	129	162	114	154	187	139	179	212	164	204	237
40	113	159	196	138	184	221	163	209	246	188	234	271

* Brackets are packaged together.

Rod Side Flange Type (F)

Single acting, Spring return: CVM3F — S

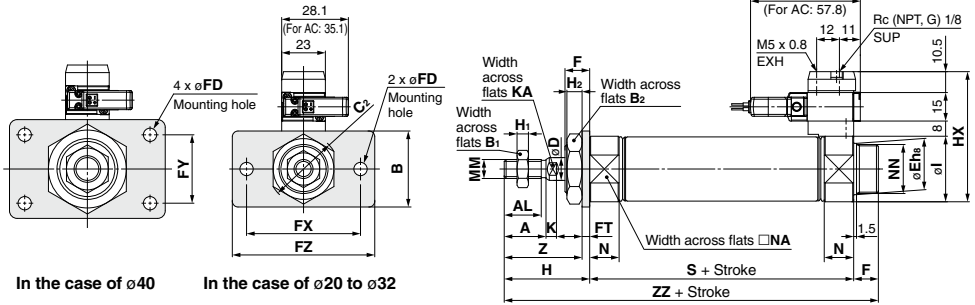

Single acting, Spring extend: CVM3F — T

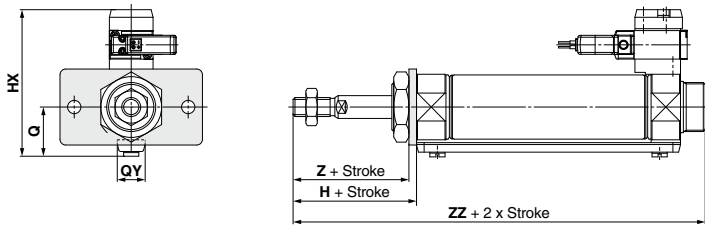

Bore size (mm)	A	AL	B	B ₁	B ₂	C ₂	D	Eh ₈	F	FD	FT	FX	FY	FZ	H	H ₁	H ₂	HX	I	K	KA
20	18	15.5	34	13	26	30	8	20 ⁰ _{-0.033}	13	7	4	60	—	75	41	5	8	57.5	28	5	6
25	22	19.5	40	17	32	37	10	26 ⁰ _{-0.033}	13	7	4	60	—	75	45	6	8	63.5	33.5	5.5	8
32	22	19.5	40	17	32	37	12	26 ⁰ _{-0.033}	13	7	4	60	—	75	45	6	8	68	37.5	5.5	10
40	24	21	52	22	41	47.3	14	32 ⁰ _{-0.039}	16	7	5	66	36	82	50	8	10	76	46.5	7	12

Bore size (mm)	MM	N	NA	NN	Z	Dimensions by Stroke (mm)										Single Acting/Spring Extend (mm)				
						Stroke 1 to 50		51 to 100		101 to 150		151 to 200		201 to 250		Bore size (mm)	HX	Q	QY	
Bore size (mm)	Symbol	S	ZZ	S	ZZ	S	ZZ	S	ZZ	S	ZZ	S	ZZ	S	ZZ					
20	87	141	112	166	137	191	—	—	—	—	—	—	—	—	—	20	65.3	19.8	14	
25	87	145	112	170	137	195	—	—	—	—	—	—	—	—	—	25	70.5	22	14	
32	89	147	114	172	139	197	164	222	—	—	—	—	—	—	—	32	76.5	25.8	16	
40	113	179	138	204	163	229	188	254	213	279	—	—	—	—	—	40	84.5	29.8	16	

* Brackets are packaged together.

CVM3 Series

Head Side Flange Type (G)

Single acting, Spring return: CVM3G — S

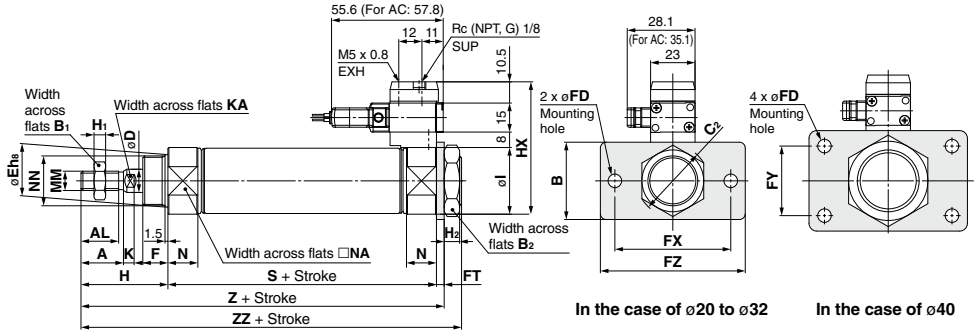

Single acting, Spring extend: CVM3G — T

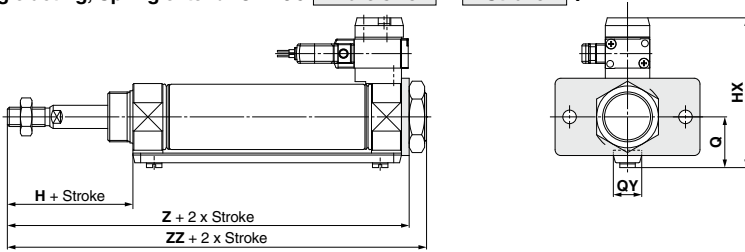

Bore size (mm)	A	AL	B	B ₁	B ₂	C ₂	D	Eh ₈	F	FD	FT	FX	FY	FZ	H	H ₁	H ₂	HX	I	K	KA	MM
20	18	15.5	34	13	26	30	8	20 ⁰ _{-0.033}	13	7	4	60	—	75	41	5	8	57.5	28	5	6	M8 x 1.25
25	22	19.5	40	17	32	37	10	26 ⁰ _{-0.033}	13	7	4	60	—	75	45	6	8	63.5	33.5	5.5	8	M10 x 1.25
32	22	19.5	40	17	32	37	12	26 ⁰ _{-0.033}	13	7	4	60	—	75	45	6	8	68	37.5	5.5	10	M10 x 1.25
40	24	21	52	22	41	47.3	14	32 ⁰ _{-0.039}	16	7	5	66	36	82	50	8	10	76	46.5	7	12	M14 x 1.5

Bore size (mm)	N	NA	NN	Dimensions by Stroke (mm)												Single Acting/Spring Extend (mm)						
				Stroke Symbol			1 to 50			51 to 100			101 to 150			151 to 200			201 to 250			Bore size (mm)
Bore size (mm)	S	Z	ZZ	S	Z	ZZ	S	Z	ZZ	S	Z	ZZ	S	Z	ZZ	S	Z	ZZ				
20	87	132	141	112	157	166	137	182	191	—	—	—	—	—	—	—	—	—	20	65.3	19.8	14
25	87	136	145	112	161	170	137	186	195	—	—	—	—	—	—	—	—	—	25	70.5	22	14
32	89	138	147	114	163	172	139	188	197	164	213	222	—	—	—	—	—	—	32	76.5	25.8	16
40	113	168	179	138	193	204	163	218	229	188	243	254	213	268	279	—	—	—	40	84.5	29.8	16

* Brackets are packaged together.

Single Clevis Type (C)

Single acting, Spring return: CVM3C — S

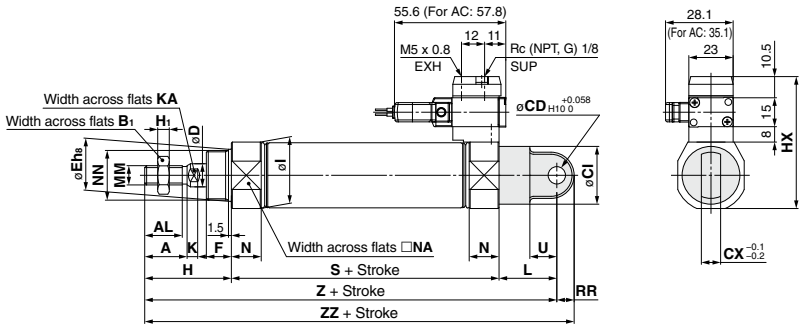

Single acting, Spring extend: CVM3C — T

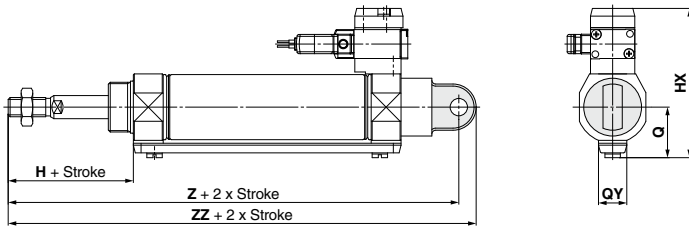

Bore size (mm)	A	AL	B ₁	CD	CI	CX	D	Eh _e	F	H	H ₁	HX	I	K	KA	L	MM	N	NA	NN	RR	U
20	18	15.5	13	9	24	10	8	20 ⁰ _{-0.033}	13	41	5	57.5	28	5	6	30	M8 x 1.25	15	24	M20 x 1.5	9	14
25	22	19.5	17	9	30	10	10	26 ⁰ _{-0.033}	13	45	6	63.5	33.5	5.5	8	30	M10 x 1.25	15	30	M26 x 1.5	9	14
32	22	19.5	17	9	30	10	12	26 ⁰ _{-0.033}	13	45	6	68	37.5	5.5	10	30	M10 x 1.25	15	34.5	M26 x 1.5	9	14
40	24	21	22	10	38	15	14	32 ⁰ _{-0.039}	16	50	8	76	46.5	7	12	39	M14 x 1.5	21.5	42.5	M32 x 2	11	18

Dimensions by Stroke

Bore size (mm)	Stroke Symbol		1 to 50		51 to 100		101 to 150		151 to 200		201 to 250	
	S	Z	ZZ	S	Z	ZZ	S	Z	ZZ	S	Z	ZZ
20	87	158	167	112	183	192	137	208	217	—	—	—
25	87	162	171	112	187	196	137	212	221	—	—	—
32	89	164	173	114	189	198	139	214	223	164	239	248
40	113	202	213	138	227	238	163	252	263	188	277	288

Single Acting/Spring Extend (mm)

Bore size (mm)	HX	Q	QY
20	65.3	19.8	14
25	70.5	22	14
32	76.5	25.8	16
40	84.5	29.8	16

CVM3 Series

Double Clevis Type (D)

Single acting, Spring return: CVM3D — S

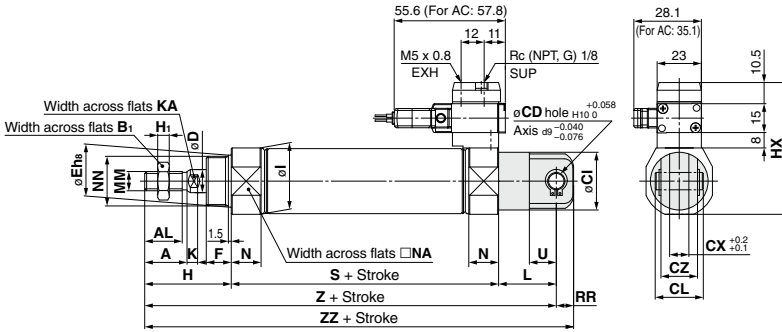

Single acting, Spring extend: CVM3D — T

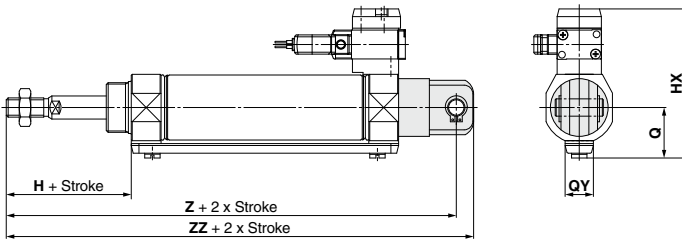

Bore size (mm)	A	AL	B ₁	CD	CI	CL	CX	CZ	D	Eh ₈	F	H	H ₁	HX	I	K	KA	L	MM	N	NA	NN	RR	U
20	18	15.5	13	9	24	25	10	19	8	20 ^{0.033}	13	41	5	57.5	28	5	6	30	M8 x 1.25	15	24	M20 x 1.5	9	14
25	22	19.5	17	9	30	25	10	19	10	26 ^{0.033}	13	45	6	63.5	33.5	5.5	8	30	M10 x 1.25	15	30	M26 x 1.5	9	14
32	22	19.5	17	9	30	25	10	19	12	26 ^{0.033}	13	45	6	68	37.5	5.5	10	30	M10 x 1.25	15	34.5	M26 x 1.5	9	14
40	24	21	22	10	38	41.2	15	30	14	32 ^{0.038}	16	50	8	76	46.5	7	12	39	M14 x 1.5	21.5	42.5	M32 x 2	11	18

Dimensions by Stroke

Bore size (mm)	Stroke (mm)																							
	1 to 50				51 to 100				101 to 150				151 to 200				201 to 250							
Symbol	S	Z	ZZ	S	Z	ZZ	S	Z	ZZ	S	Z	ZZ	S	Z	ZZ	S	Z	ZZ	S	Z	ZZ	S	Z	ZZ
20	87	158	167	112	183	192	137	208	217	—	—	—	—	—	—	—	—	—	—	—	—	—	—	—
25	87	162	171	112	187	196	137	212	221	—	—	—	—	—	—	—	—	—	—	—	—	—	—	—
32	89	164	173	114	189	198	139	214	223	164	239	248	—	—	—	—	—	—	—	—	—	—	—	—
40	113	202	213	138	227	238	163	252	263	188	277	288	213	302	313	—	—	—	—	—	—	—	—	—

Single Acting/Spring Extend (mm)

Bore size (mm)	HX	Q	QY
20	65.3	19.8	14
25	70.5	22	14
32	76.5	25.8	16
40	84.5	29.8	16

* Clevis pin and snap ring (cotter pin for ø40) is shipped together.

Rod Side Trunnion Type (U)

Single acting, Spring return: CVM3U — S

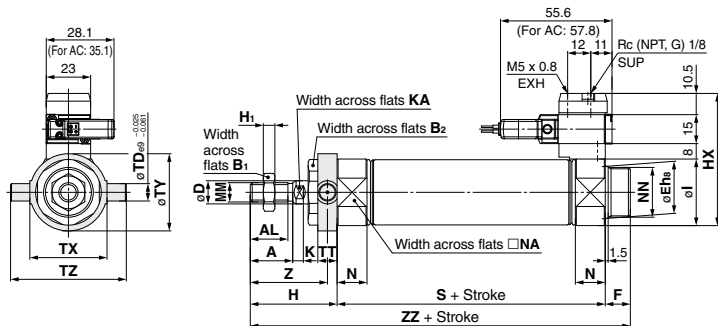

Single acting, Spring extend: CVM3U — T

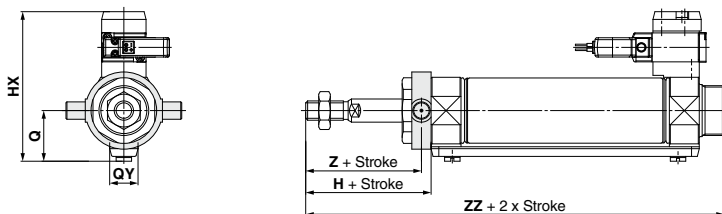

Bore size (mm)	A	AL	B ₁	B ₂	D	Eh ₈	F	H	H ₁	HX	I	K	KA	MM	N	NA	NN	TD	TT	TX	TY	TZ	Z
20	18	15.5	13	26	8	20 ⁰ _{-0.033}	13	41	5	57.5	28	5	6	M8 x 1.25	15	24	M20 x 1.5	8	10	32	32	52	36
25	22	19.5	17	32	10	26 ⁰ _{-0.033}	13	45	6	63.5	33.5	5.5	8	M10 x 1.25	15	30	M26 x 1.5	9	10	40	40	60	40
32	22	19.5	17	32	12	26 ⁰ _{-0.033}	13	45	6	68	37.5	5.5	10	M10 x 1.25	15	34.5	M26 x 1.5	9	10	40	40	60	40
40	24	21	22	41	14	32 ⁰ _{-0.039}	16	50	8	76	46.5	7	12	M14 x 1.5	21.5	42.5	M32 x 2	10	11	53	53	77	44.5

Stroke		(mm)																						
Bore size (mm)	Symbol	1 to 50	51 to 100	101 to 150	151 to 200	201 to 250																		
		S	ZZ	S	ZZ	S	ZZ	S	ZZ	S	ZZ													
20		87	141	112	166	137	191	—	—	—	—	—	—	—	—	—	—	—	—	—	—	—	—	
25		87	145	112	170	137	195	—	—	—	—	—	—	—	—	—	—	—	—	—	—	—	—	—
32		89	147	114	172	139	197	164	222	—	—	—	—	—	—	—	—	—	—	—	—	—	—	—
40		113	179	138	204	163	229	188	254	213	279	—	—	—	—	—	—	—	—	—	—	—	—	—

Single Acting/Spring Extend (mm)			
Bore size (mm)	HX	Q	QY
20	65.3	19.8	14
25	70.5	22	14
32	76.5	25.8	16
40	84.5	29.8	16

* Brackets are packaged together.

CVM3 Series

Head Side Trunnion Type (T)

Single acting, Spring return: CVM3T — S

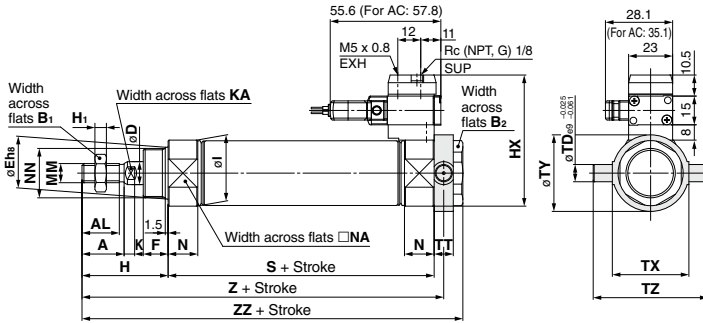

Single acting, Spring extend: CVM3T — T

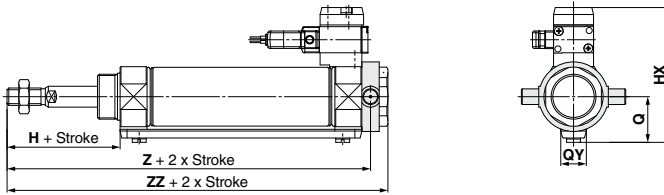

Bore size (mm)	A	AL	B ₁	B ₂	D	E _{H8}	F	H	H ₁	HX	I	K	KA	MM	N	NA	NN	TD	TT	TX	TY	TZ
20	18	15.5	13	26	8	20 ⁰ _{-0.033}	13	41	5	57.5	28	5	6	M8 x 1.25	15	24	M20 x 1.5	8	10	32	32	52
25	22	19.5	17	32	10	26 ⁰ _{-0.033}	13	45	6	63.5	33.5	5.5	8	M10 x 1.25	15	30	M26 x 1.5	9	10	40	40	60
32	22	19.5	17	32	12	26 ⁰ _{-0.033}	13	45	6	68	37.5	5.5	10	M10 x 1.25	15	34.5	M26 x 1.5	9	10	40	40	60
40	24	21	22	41	14	32 ⁰ _{-0.039}	16	50	8	76	46.5	7	12	M14 x 1.5	21.5	42.5	M32 x 2	10	11	53	53	77

Dimensions by Stroke

Bore size (mm)	Stroke Symbol		1 to 50			51 to 100			101 to 150			151 to 200			201 to 250		
	S	Z	ZZ	S	Z	ZZ	S	Z	ZZ	S	Z	ZZ	S	Z	ZZ		
20	87	133	143	112	158	168	137	183	193	—	—	—	—	—	—		
25	87	137	147	112	162	172	137	187	197	—	—	—	—	—	—		
32	89	139	149	114	164	174	139	189	199	164	214	224	—	—	—		
40	113	168.5	179	138	193.5	204	163	218.5	229	188	243.5	254	213	268.5	279		

Single Acting/Spring Extend (mm)

Bore size (mm)	HX	Q	QY
20	65.3	19.8	14
25	70.5	22	14
32	76.5	25.8	16
40	84.5	29.8	16

* Brackets are packaged together.

CVM3K Series

A hexagon shaped rod that does not rotate.

Non-rotating accuracy

$\phi 20, \phi 25 - \pm 0.7^\circ$
 $\phi 32, \phi 40 - \pm 0.5^\circ$

Can operate without lubrication.

Auto switches can also be mounted.

Can be installed with auto switches to facilitate the detection of the cylinder's stroke position.



Symbol

Rubber bumper

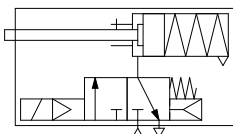
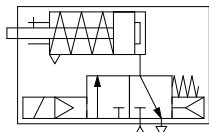

Made to Order Specifications

[Click here for details](#)

Symbol	Specifications
-XA□	Change of rod end shape

Mounting Bracket Part No.

Bore size (mm)	20	25	32	40
Axial foot*	CM-L020B	CM-L032B	CM-L040B	CM-L040B
Flange	CM-F020B	CM-F032B	CM-F040B	CM-F040B
Single clevis	CM-C020B	CM-C032B	CM-C040B	CM-C040B
Double clevis**	CM-D020B	CM-D032B	CM-D040B	CM-D040B
Trunnion (With nut)	CM-T020B	CM-T032B	CM-T040B	CM-T040B

* Two foot brackets and a mounting nut are attached.

When ordering the foot bracket, order 2 pcs. per cylinder.

** Clevis pin and retaining ring (cotter pin for $\phi 40$) are packaged together.

Specifications

Applicable bore size (mm)	20	25	32	40
Rod non-rotating accuracy	$\pm 0.7^\circ$ / $\pm 0.5^\circ$			
Action	Single acting, Spring return/Spring extend			
Fluid	Air			
Cushion	Rubber bumper			
Proof pressure	1.0 MPa			
Maximum operating pressure	0.7 MPa			
Minimum operating pressure	0.18 MPa spring return	0.23 MPa spring extend		
Ambient and fluid temperature	-10 to 50°C (No freezing)			
Lubrication	Not required (Non-lube)			
Stroke length tolerance	$+1.4$ 0			
Piping	Screw-in type	Rc 1/8		
	Built-in One-touch fitting	O.D.: $\phi 6$ /I.D.: $\phi 4$		
Piston speed (mm/s)	50 to 700	50 to 650	50 to 590	50 to 420
Allowable kinetic energy	0.27 J	0.4 J	0.65 J	1.2 J
Mounting	Basic type, Axial foot type, Rod side flange type, Head side flange type, Single clevis type, Double clevis type, Head side trunnion type, Rod side trunnion type			

Solenoid Valve Specifications

Series		SYJ519		
Manual override	Non-locking push type, Push-turn locking slotted type, Push-turn locking lever type			
Pilot exhaust	Pilot valve individual exh. Type			
Impact/Vibration resistance (m/s ²) ^{Note 1)}	150/30			
Enclosure	Dustproof			
Electrical entry	Grommet (G), L plug connector (L), M plug connector (M), DIN terminal (D)			
	G, L, M	D		
Coil rated voltage (V)	DC	24, 12, 6, 5, 3		
	AC 50/60 Hz	100, 110, 200, 220		
Allowable voltage	$\pm 10\%$ of the rated voltage*			
Power consumption (W) ^{Note 2)}	DC	0.35 (With light: 0.4 (DIN terminal with light: 0.45))		
	AC	100 V	0.78 (With light: 0.81)	0.78 (With light: 0.87)
Apparent power (VA) ^{Note 2)}	AC	110 V	0.86 (With light: 0.89)	0.86 (With light: 0.97)
		[115 V]	[0.94 (With light: 0.97)]	[0.94 (With light: 1.07)]
		200 V	1.18 (With light: 1.22)	1.15 (With light: 1.30)
		220 V	1.30 (With light: 1.34)	1.27 (With light: 1.46)
		[230 V]	[1.42 (With light: 1.46)]	[1.39 (With light: 1.60)]
Surge voltage suppressor	Diode (DIN terminal, Varistor when non-polar types)			
Indicator light	LED (Neon light when AC with DIN terminal)			

* Based on IEC60529

* In common between 110 VAC and 115 VAC, and between 220 VAC and 230 VAC.

* For 115 VAC and 230 VAC, the allowable voltage is -15% to $+5\%$ of rated voltage.

Note 1) Impact resistance: No malfunction occurred when it is tested in the axial direction and at the right angles to the main valve and armature in both energized and de-energized states every once for each condition. (Values at the initial period)

Vibration resistance: No malfunction occurred in a one-sweep test between 45 and 2000 Hz. The test was performed at both energized and de-energized states in the axial direction and at the right angles to the main valve and armature. (Values at the initial period)

Note 2) At the rated voltage.

Standard Stroke

Bore size (mm)	Standard stroke (mm) ^{Note)}
20	25, 50, 75, 100, 125, 150 *
25	25, 50, 75, 100, 125, 150 *
32	25, 50, 75, 100, 125, 150, 200 *
40	25, 50, 75, 100, 125, 150, 200, 250 *

Note 1) Intermediate stroke other than above is manufactured upon receipt of order.

Note 2) Strokes marked with "*" are the maximum strokes which are available.

Refer to pages 1212 to 1215 for cylinders with auto switches.

- Proper auto switch mounting position (detection at stroke end) and mounting height
- Minimum auto switch mounting stroke
- Operating range
- Auto switch mounting bracket: Part no.

Theoretical Output

Refer to the Technical Data (Theoretical Output 1) in the [Web Catalog](#).

Spring Reaction Force

Refer to the Technical Data (Table 2: Spring Reaction Force) in the [Web Catalog](#).

Valve Mounted Cylinder: Non-rotating Rod Type Single Acting, Spring Return/Extend **CVM3K Series**

Mounting Bracket and Accessory

Accessory	Standard equipment			Option			
	Mounting nut	Rod end nut	Clevis pin	Single knuckle joint	Double knuckle joint ⁽³⁾	Pivot bracket ⁽⁵⁾	Pivot bracket pin ⁽⁶⁾
Mounting							
Basic type	● (1 pc.)	●	—	●	●		
Axial foot type	● (2)	●	—	●	●		
Rod side flange type	● (1)	●	—	●	●		
Head side flange type	● (1)	●	—	●	●		
Single clevis type	— ⁽¹⁾	●	—	●	●	●	●
Double clevis type ⁽³⁾	— ⁽¹⁾	●	● ⁽⁴⁾	●	●	—	—
Head side trunnion type	● (1) ⁽²⁾	●	—	●	●	●	—
Rod side trunnion type	● (1) ⁽²⁾	●	—	●	●		—

- Note 1) Mounting nut is not equipped with single clevis type and double clevis type.
 Note 2) Trunnion nuts are equipped for head side trunnion and rod side trunnion.
 Note 3) Pin and retaining ring are shipped together with double clevis and double knuckle joint.
 Note 4) Retaining rings (cotter pins for ø40) are included in clevis pins.
 Note 5) Pin and retaining ring are not included in pivot bracket.
 Note 6) Retaining rings are included in pivot bracket pin.

Weight

Spring Return/(): Denotes Spring Extend.

Bore size (mm)		20	25	32	40
Basic weight	25 stroke	0.27 (0.27)	0.37 (0.37)	0.49 (0.48)	0.84 (0.83)
	50 stroke	0.29 (0.29)	0.40 (0.40)	0.53 (0.53)	0.91 (0.90)
	75 stroke	0.34 (0.34)	0.49 (0.48)	0.65 (0.63)	1.10 (1.06)
	100 stroke	0.36 (0.36)	0.52 (0.51)	0.70 (0.67)	1.16 (1.13)
	125 stroke	0.42 (0.41)	0.61 (0.58)	0.83 (0.79)	1.36 (1.30)
	150 stroke	0.44 (0.43)	0.64 (0.61)	0.87 (0.83)	1.43 (1.37)
	200 stroke	—	—	1.03 (0.99)	1.68 (1.60)
250 stroke	—	—	—	1.94 (1.82)	
Mounting bracket weight	Axial foot	0.15 (0.15)	0.16 (0.16)	0.16 (0.16)	0.27 (0.27)
	Flange	0.06 (0.06)	0.09 (0.09)	0.09 (0.09)	0.12 (0.12)
	Single clevis	0.04 (0.04)	0.04 (0.04)	0.04 (0.04)	0.09 (0.09)
	Double clevis	0.05 (0.05)	0.06 (0.06)	0.06 (0.06)	0.13 (0.13)
	Trunnion	0.04 (0.04)	0.07 (0.07)	0.07 (0.07)	0.10 (0.10)
Option bracket weight	Single knuckle joint	0.06 (0.06)	0.06 (0.06)	0.06 (0.06)	0.23 (0.23)
	Double knuckle (With pin)	0.07 (0.07)	0.07 (0.07)	0.07 (0.07)	0.20 (0.20)

Calculation: (Example) CVM3K132-100S-1G (ø32, 100 stroke, Spring return)

- Basic weight:0.70 (kg)
- Weight of brackets:0.16 (kg)
- 0.70 + 0.16 = 0.86 kg
- Add 0.03 kg for the DIN terminal.

Manual Operation

Manual operation is possible by pushing the manual button indicated with the arrow.

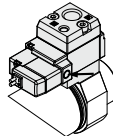

⚠ Precautions

Be sure to read this before handling the products. Refer to page 9 for safety instructions, pages 10 to 19 for actuator and auto switch precautions, and 3/4/5 port solenoid valve precautions on the SMC web site: <https://www.smworld.com>

Operating Precautions

⚠ Caution

1. Avoid using the air cylinder in such a way that rotational torque would be applied to the piston rod.

If rotational torque is applied, the non-rotating guide will deform, causing a loss of non-rotating accuracy. Also, to screw a bracket or a nut onto the threaded portion at the end of the piston rod, make sure to retract the piston rod entirely, and place a wrench on the parallel sections of the rod that protrudes. To tighten, take precautions to prevent the tightening torque from being applied to the non-rotating guide.

Allowable rotational torque (N·m or less)	ø20	ø25	ø32	ø40
	0.2	0.25	0.25	0.44

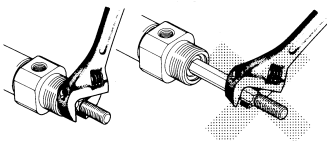

Disassembly/Replacement

⚠ Caution

1. The rod seal replacement procedure is the same as that of the CM2□ standard type. After installing the rod seal, be sure to confirm that the piston rod and rod seal width across flats are not misaligned.

Model Selection

⚠ Warning

1. Confirm the specifications. Products in this catalog are designed to be used for compressed air systems. If not operated within the designated pressure or temperature, it may damage the products or cause malfunction. (Refer to specifications.)
2. Energizing continuously for a long period of time. When the valve is continuously energized for a long period of time, the performance may deteriorate or affect peripheral equipment adversely since temperature rises when coils generate heat.

Valve Mounted Cylinder: Non-rotating Rod Type Single Acting, Spring Return/Extend **CVM3K Series**

Basic Type (B): External Dimensions

Single acting, Spring return: CVM3KB Bore size — Stroke **S**

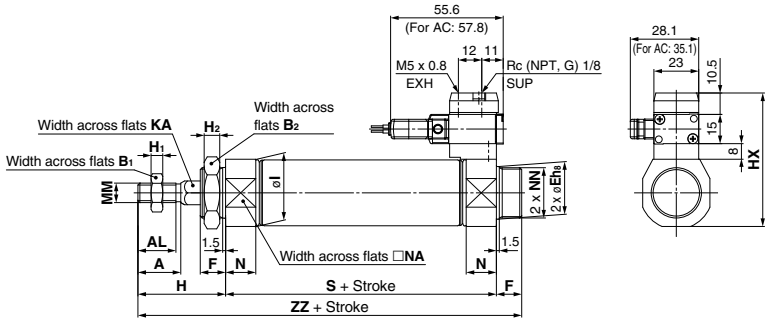

Single acting, Spring extend: CVM3KB Bore size — Stroke **T**

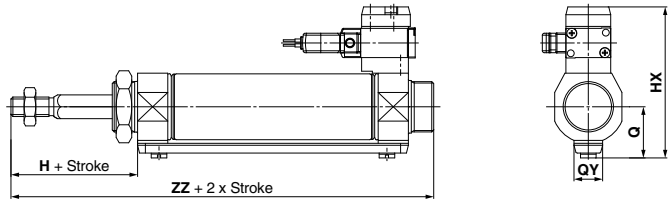

Built-in One-touch fitting

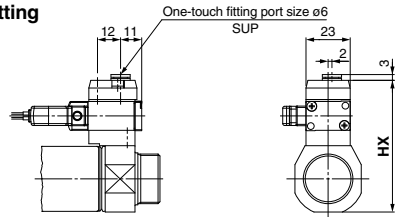

Bore size (mm)	(mm)															
	A	AL	B1	B2	Eh8	F	H	H1	H2	HX	I	KA	MM	N	NA	NN
20	18	15.5	13	26	20 ⁰ _{-0.033}	13	41	5	8	57.5	28	8.2	M8 x 1.25	15	24	M20 x 1.5
25	22	19.5	17	32	26 ⁰ _{-0.033}	13	45	6	8	63.5	33.5	10.2	M10 x 1.25	15	30	M26 x 1.5
32	22	19.5	17	32	26 ⁰ _{-0.033}	13	45	6	8	68	37.5	12.2	M10 x 1.25	15	34.5	M26 x 1.5
40	24	21	22	41	32 ⁰ _{-0.039}	16	50	8	10	76	46.5	14.2	M14 x 1.5	21.5	42.5	M32 x 2

Dimensions by Stroke

Bore size (mm)	(mm)									
	1 to 50		51 to 100		101 to 150		151 to 200		201 to 250	
Stroke Symbol	S	ZZ	S	ZZ	S	ZZ	S	ZZ	S	ZZ
20	87	141	112	166	137	191	—	—	—	—
25	87	145	112	170	137	195	—	—	—	—
32	89	147	114	172	139	197	164	222	—	—
40	113	179	138	204	163	229	188	254	213	279

Single Acting/Spring Extend (mm)

Bore size (mm)	HX	Q	QY
20	65.3	19.8	14
25	70.5	22	14
32	76.5	25.8	16
40	84.5	29.8	16

Auto Switch Mounting 1

Auto Switch Proper Mounting Position (Detection at Stroke End) and Its Mounting Height

Reed auto switch

D-A9□

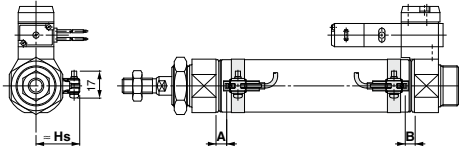

A and B are the dimensions from the end of the head cover/rod cover to the end of the auto switch.

D-C7/C8

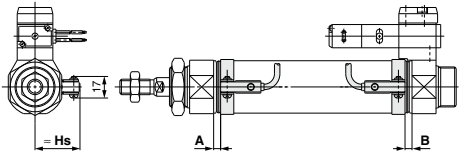

D-B5/B6/B59W

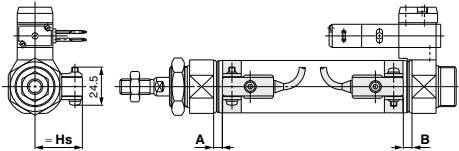

D-C73C/C80C

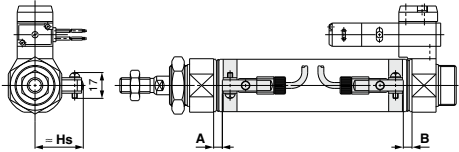

Solid state auto switch

**D-M9□
D-M9□W**

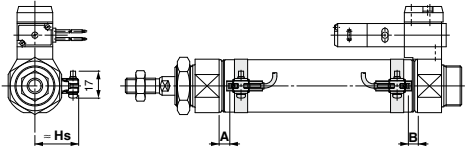

D-H7□/H7□W/H7NF

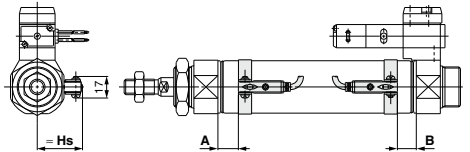

D-G5NT

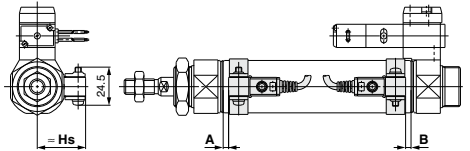

D-H7C

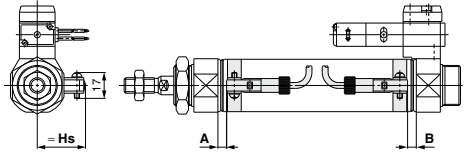

**Auto Switch Proper Mounting Position (Detection at Stroke End)
and Its Mounting Height: Single Acting, Spring Return (S)/Spring Extend (T)**

**Auto Switch Proper Mounting Position: Standard, Spring Return (S)
Non-Rotating, Spring Return (S)** (mm)

Auto switch model	Bore size	A dimension					B
		to 15 st	51 to 100 st	101 to 150 st	151 to 200 st	201 to 250 st	
D-A9□(V)	20	31.5	56.5	81.5	—	—	5.5
	25	31.5	56.5	81.5	—	—	5.5
	32	32.5	57.5	82.5	107.5	—	6.5
	40	38.5	63.5	88.5	113.5	138.5	11.5
D-M9□(V) D-M9□W(V) D-M9□A(V)	20	35.5	60.5	85.5	—	—	9.5
	25	35.5	60.5	85.5	—	—	9.5
	32	36.5	61.5	86.5	111.5	—	10.5
	40	42.5	67.5	92.5	117.5	142.5	15.5
D-B5□ D-B64	20	26	51	76	—	—	0
	25	26	51	76	—	—	0
	32	27	52	77	102	—	1
	40	32	57	82	107	132	6
D-C7□ D-C80 D-C73C D-C80C	20	32	57	82	—	—	6
	25	32	57	82	—	—	6
	32	33	58	83	108	—	7
	40	38	63	88	113	138	12
D-B59W	20	29	54	79	—	—	3
	25	29	54	79	—	—	3
	32	30	55	80	105	—	4
	40	35	60	85	110	135	9
D-H7□ D-H7C D-H7□W D-H7NF	20	31	56	81	—	—	5
	25	31	56	81	—	—	5
	32	32	57	82	107	—	6
	40	37	62	87	112	137	11
D-G5NT	20	27.5	52.5	77.5	—	—	1.5
	25	27.5	52.5	77.5	—	—	1.5
	32	28.5	53.5	78.5	103.5	—	2.5
	40	33.5	58.5	83.5	108.5	133.5	7.5

**Auto Switch Proper Mounting Position: Standard, Spring Extend (T)
Non-Rotating, Spring Extend (T)** (mm)

Auto switch model	Bore size	A	B dimension				
			to 15 st	51 to 100 st	101 to 150 st	151 to 200 st	201 to 250 st
D-A9□(V)	20	6.5	30.5	55.5	80.5	—	—
	25	6.5	30.5	55.5	80.5	—	—
	32	7.5	31.5	56.5	81.5	106.5	—
	40	13.5	36.5	61.5	86.5	111.5	136.5
D-M9□(V) D-M9□W(V) D-M9□A(V)	20	10.5	34.5	59.5	84.5	—	—
	25	10.5	34.5	59.5	84.5	—	—
	32	11.5	35.5	60.5	85.5	110.5	—
	40	17.5	40.5	65.5	90.5	115.5	140.5
D-B5□ D-B64	20	1	25	50	75	—	—
	25	1	25	50	75	—	—
	32	2	26	51	76	101	—
	40	7	31	56	81	106	131
D-C7□ D-C80 D-C73C D-C80C	20	7	31	56	81	—	—
	25	7	31	56	81	—	—
	32	8	32	57	82	107	—
	40	13	37	62	87	112	137
D-B59W	20	4	28	53	78	—	—
	25	4	28	53	78	—	—
	32	5	29	54	79	104	—
	40	10	34	59	84	109	134
D-H7□ D-H7C D-H7□W D-H7NF	20	6	30	55	80	—	—
	25	6	30	55	80	—	—
	32	7	31	56	81	106	—
	40	12	36	61	86	111	136
D-G5NT	20	2.5	26.5	51.5	76.5	—	—
	25	2.5	26.5	51.5	76.5	—	—
	32	3.5	27.5	52.5	77.5	102.5	—
	40	8.5	32.5	57.5	81.5	107.5	132.5

Note) Adjust the auto switch after confirming the operating conditions in the actual setting.

Auto Switch Mounting 2

Auto Switch Proper Mounting Position (Detection at Stroke End) and Its Mounting Height

Auto Switch Mounting Height

(mm)

Auto switch model Bore size (mm)	D-A9□(V) D-M9□(V) D-M9□W(V) D-M9□A(V)	D-B5□ D-B64 D-B59W D-G5NT D-H7C	D-C7□ D-C80 D-H7□ D-H7□W D-H7NF	D-C73C D-C80C
	Hs	Hs	Hs	Hs
20	23	25.5	22.5	25
25	25.5	28	25	27.5
32	29	31.5	28.5	31
40	33	35.5	32.5	35

Minimum Auto Switch Mounting Stroke

n: No. of auto switches (mm)

Auto switch model	No. of auto switch mounted				
	1	2		n	
		Different surfaces	Same surface	Different surfaces	Same surface
D-A9□ D-M9□ D-M9□W	10	15 <small>Note 1</small>	45 <small>Note 1</small>	$15 + 45 \frac{(n-2)}{2}$ <small>(n = 2, 4, 6...)</small> <small>Note 2</small>	$45 + 45 (n-2)$ <small>(n = 2, 3, 4, 5...)</small>
D-M9□V	5	20	35	$20 + 35 \frac{(n-2)}{2}$ <small>(n = 2, 4, 6...)</small> <small>Note 2</small>	$35 + 35 (n-2)$ <small>(n = 2, 3, 4, 5...)</small>
D-A9□V	5	15	25	$15 + 35 \frac{(n-2)}{2}$ <small>(n = 2, 4, 6...)</small> <small>Note 2</small>	$25 + 35 (n-2)$ <small>(n = 2, 3, 4, 5...)</small>
D-M9□WV D-M9□AV	10	20	35	$20 + 35 \frac{(n-2)}{2}$ <small>(n = 2, 4, 6...)</small> <small>Note 2</small>	$35 + 35 (n-2)$ <small>(n = 2, 3, 4, 5...)</small>
D-C7□ D-C80	10	15	50	$15 + 45 \frac{(n-2)}{2}$ <small>(n = 2, 4, 6...)</small> <small>Note 2</small>	$50 + 45 (n-2)$ <small>(n = 2, 3, 4, 5...)</small>
D-H7□ D-H7□W D-H7NF	10	15	60	$15 + 45 \frac{(n-2)}{2}$ <small>(n = 2, 4, 6...)</small> <small>Note 2</small>	$60 + 45 (n-2)$ <small>(n = 2, 3, 4, 5...)</small>
D-C73C D-C80C D-H7C	10	15	65	$15 + 50 \frac{(n-2)}{2}$ <small>(n = 2, 4, 6...)</small> <small>Note 2</small>	$65 + 50 (n-2)$ <small>(n = 2, 3, 4, 5...)</small>
D-B5□/B64 D-G5NT	10	15	75	$15 + 50 \frac{(n-2)}{2}$ <small>(n = 2, 4, 6...)</small> <small>Note 2</small>	$75 + 55 (n-2)$ <small>(n = 2, 3, 4, 5...)</small>
D-B59W	15	20	75	$20 + 50 \frac{(n-2)}{2}$ <small>(n = 2, 4, 6...)</small> <small>Note 2</small>	$75 + 55 (n-2)$ <small>(n = 2, 3, 4, 5...)</small>

Note 2) When "n" is an odd number, an even number that is one larger than this odd number is used for the calculation.

Note 1) Auto switch mounting (The adjustment as shown in the figures below is required with the following stroke ranges.)

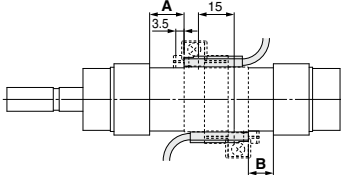
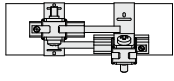
Auto switch model	With 2 auto switches	
	Different surfaces <small>Note 1</small>	Same surface <small>Note 1</small>
	 <p>The proper auto switch mounting position is 6 mm inward from the switch holder edge.</p>	 <p>The auto switch is mounted by slightly displacing it in a direction (cylinder tube circumferential exterior) so that the auto switch and lead wire do not interfere with each other.</p>
D-A93	—	45 to less than 50 stroke
D-M9□ D-M9□W	15 to less than 20 stroke	45 to less than 55 stroke

Operating Range

Auto switch model	Bore size (mm)			
	20	25	32	40
D-A9□(V)	6	6	6	6
D-M9□(V)/M9□W(V) D-M9□A(V)	3.5	3	3.5	3
D-C7□/C80 D-C73C/C80C	7	8	8	8
D-B5□/B64	8	8	9	9
D-B59W	12	12	13	13
D-H7□/H7□W D-G5NT/H7NF	4	4	4.5	5
D-H7C	7	8.5	9	10

* Since the operating range is provided as a guideline including hysteresis, it cannot be guaranteed (assuming approximately ±30% dispersion).
It may vary substantially depending on an ambient environment.

[Mounting screw set made of stainless steel]

The following set of mounting screws made of stainless steel is available. Use it in accordance with the operating environment. (Please order the auto switch mounting bracket separately, since it is not included.)

BBA4: For D-C7/C8/H7 types

Note) Refer to page 1440 for the details of BBA4.

Auto Switch Mounting Bracket: Part No.

Auto switch mounting	Bore size (mm)			
	φ20	φ25	φ32	φ40
D-M9□(V) D-M9□W(V) D-A9□(V)	Note 1) BM5-020 (A set of a, b, c, d)	Note 1) BM5-025 (A set of a, b, c, d)	Note 1) BM5-032 (A set of a, b, c, d)	Note 1) BM5-040 (A set of a, b, c, d)
D-M9□A(V) Note 2)	BM5-020S (A set of b, c, e, f)	BM5-025S (A set of b, c, e, f)	BM5-032S (A set of b, c, e, f)	BM5-040S (A set of b, c, e, f)
D-H7□ D-H7□W D-H7NF D-C7□/C80 D-C73C/C80C	BM2-020A (A set of c and d)	BM2-025A (A set of c and d)	BM2-032A (A set of c and d)	BM2-040A (A set of c and d)
D-B5□/B64 D-B59W D-G5NT	BA2-020 (A set of c and d)	BA2-025 (A set of c and d)	BA2-032 (A set of c and d)	BA2-040 (A set of c and d)

Note 1) As the switch bracket is made of polyamide, its performance may be affected by chemicals such as alcohol, chloroform, methylamines, hydrochloric acid, and sulfuric acid, so it cannot be used in environments where these chemicals come into contact with the product.

Note 2) When mounting a D-M9□A(V) type auto switch, if the switch bracket is mounted on the indicator light, it may damage the auto switch. Therefore, be sure to avoid mounting the switch bracket on the indicator light.

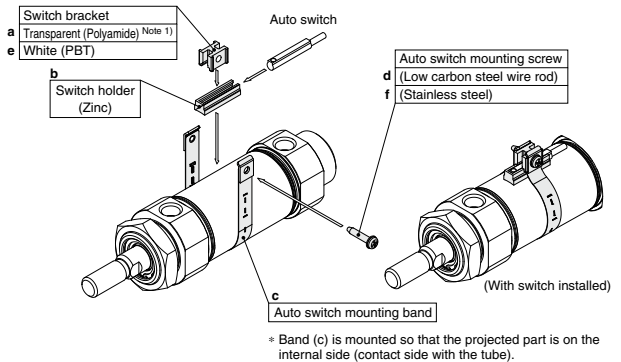

* Band (c) is mounted so that the projected part is on the internal side (contact side with the tube).

Besides the models listed in How to Order, the following auto switches are applicable.
Refer to pages 1341 to 1435 for detailed specifications.

Auto switch type	Part no.	Electrical entry (Fetching direction)	Features
Reed	D-B53, C73, C76	Grommet (In-let)	—
	D-C80		Without indicator light
Solid state	D-H7A1, H7A2, H7B		—
	D-H7NW, H7PW, H7BW		Diagnostic indication (2-color)
	D-G5NT	With timer	

* For solid state auto switches, auto switches with a pre-wired connector are also available. Refer to pages 1410 and 1411 for details.
* Normally closed (NC = b contact) solid state auto switches (D-M9□E(V)) are also available. Refer to page 1360 for details.

Valve Mounted Cylinder

Double Acting

CV3 Series

∅40, ∅50, ∅63, ∅80, ∅100

How to Order

Built-in Magnet Cylinder Model

If a built-in magnet cylinder without an auto switch is required, there is no need to enter the symbol for the auto switch.
(Example) CDV3LN50-100-1

Suffix for cylinder

Nil	Rod extended when energized
B	Rod retracted when energized

* Symbol "B" is not required for double solenoid.

Electrical entry

Nil	Grommet
D	DIN terminal

Solenoid valve

Nil	2 position single
W	2 position double

Solenoid valve voltage

Refer to page 1217 for solenoid valve voltage.

Cylinder stroke (mm)

Refer to page 1217 for standard strokes.

CV3 L N50-100

With auto switch

CDV3 L N50-100-M9BW-1

With Auto Switch (Built-in magnet)

Mounting type

B	Basic type
L	Axial foot type
F	Rod side flange type
C*	Single clevis type
D*	Double clevis type
T	Center trunnion type

Type

Nil	Aluminum tube
F*	Steel tube

* Not available with auto switch.

Bore size

40	40 mm
50	50 mm
63	63 mm
80	80 mm
100	100 mm

Auto switch

Nil	Without auto switch
-----	---------------------

* For the applicable auto switch model, refer to the table below.

Suffix for cylinder

Rod boot	J	Nylon tarpaulin
	K	Heat resistant tarpaulin
	N	Without cushion
	R	With cushion on rod end
	H	With cushion on head end
Cushion	Nil	With cushion on both ends

Number of auto switches

Nil	2 pcs.
S	1 pc.
n	"n" pcs.

Made to Order

Refer to page 1217 for details.

* Except tubing I.D. ∅40

* When specifying symbol more than one, combine symbols alphabetically.

Applicable Auto Switches/Refer to pages 1341 to 1435 for further information on auto switches.

Type	Special function	Electrical entry	Wiring (Output)	Load voltage		Auto switch model		Lead wire length (m)					Pre-wired connector	Applicable load
				DC	AC	Tie-rod mounting	Band mounting	0.5 (Nil)	1 (M)	3 (L)	5 (Z)			
Solid state auto switch	—	Grommet	3-wire (NPN)	24 V	5 V, 12 V	M9N	G59**	●	●	●	○	○	IC circuit	Relay, PLC
			3-wire (PNP)			M9P	G5P**	●	●	●	○	○		
		2-wire	M9B	K59**	●	●	●	○	○					
		2-wire	M9B	K59**	●	●	●	○	○					
	Diagnostic indication (2-color indicator)	Terminal conduit	3-wire (NPN)	12 V	12 V	G39C	G39	—	—	—	—	—	—	
			2-wire			K39C	K39	—	—	—	—	—		
		Grommet	3-wire (NPN)	24 V	5 V, 12 V	M9NW	G59W**	●	●	●	○	○	IC circuit	
			3-wire (PNP)			M9PW	G5PW**	●	●	●	○	○		
			2-wire			M9BW	K59W**	●	●	●	○	○		
			2-wire			M9BW	K59W**	●	●	●	○	○		
Water resistant (2-color indicator)	Grommet	3-wire (NPN)	24 V	5 V, 12 V	M9NA*1	—	○	○	○	○	IC circuit			
		3-wire (PNP)			M9PA*1	—	○	○	○	○				
With diagnostic output (2-color indicator)	Grommet	2-wire	24 V	5 V, 12 V	M9BA*1	—	○	○	○	○	—			
		4-wire (NPN)			F59F	G59F**	●	—	●	○		○		
Reed auto switch	—	Grommet	2-wire	24 V	12 V	A96	—	●	●	●	○	IC circuit		
						A93	—	●	●	●	○		IC circuit	
		Terminal conduit	2-wire	24 V	12 V	A90	—	●	●	●	○	IC circuit		
						A54	B54**	●	●	●	○		—	
		DIN terminal	2-wire	24 V	12 V	A64	B64**	●	●	●	○	—		
						A33	A33	—	—	—	—		—	
		Grommet	2-wire	24 V	12 V	A34C	A34	—	—	—	—	—		
						A44C	A44	—	—	—	—			
		Diagnostic indication (2-color indicator)	Grommet	2-wire	24 V	12 V	A59W	B59W**	●	—	●	○	—	
							A59W	B59W**	●	—	●	○		

*1 Water resistant type auto switches can be mounted on the above models, but in such case SMC cannot guarantee water resistance.

*2 The load voltage used is 24 VDC.

* Lead wire length symbols: 0.5 m..... Nil (Example) M9NW
1 m..... M (Example) M9NWM
3 m..... L (Example) M9NWL
5 m..... Z (Example) M9NWZ

** Auto switches marked with "C" are produced upon receipt of order.

† D-B5C/B64/G5/K5 types are mountable only upon a receipt of order. (Not mountable after the time of shipment)

* Since there are other applicable auto switches than listed, refer to page 1236 for details.

* For details about auto switches with pre-wired connector, refer to pages 1410 and 1411.

* D-A9C/M9C/M9Z/M9A auto switches are shipped together (not assembled). (Only auto switch mounting brackets are assembled before shipped.)

- **Ease of maintenance and inspection.**

The solenoid valve can be separated easily and the cylinder can also be disassembled.

- **A manual operation mechanism is provided as standard equipment (non-locking).**



Symbol

Air cushion

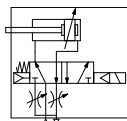

Made to Order Specifications
[Click here for details](#)

Symbol	Specifications
-XA□	Change of rod end shape
-XC4	With heavy duty scraper
-XC15	Change of tie-rod length
-XC68	Made of stainless steel

⚠ Precautions

Minimum stroke for auto switch mounting

⚠ Caution

1. Each switch and mounting type of cylinder has different minimum mountable stroke. Be careful especially of the center trunnion type. (For details, refer to pages 1234 and 1235.)

Refer to pages 1232 to 1236 for cylinders with auto switches.

- Proper auto switch mounting position (detection at stroke end) and mounting height
- Minimum auto switch mounting stroke
- Operating range
- Auto switch mounting bracket: Part no.

Specifications

Bore size (mm)	40	50	63	80	100	
Fluid	Air					
Action	Double acting					
Proof pressure	1.35 MPa					
Maximum operating pressure	0.9 MPa					
Ambient and fluid temperature	-10 to 50°C*1					
Minimum operating pressure	0.15 MPa					
Piston speed	50 to 500 mm/s				50 to 350 mm/s	
Cushion	Air cushion					
Stroke length tolerance	Up to 250 st: $^{+1.0}_0$ 251 to 1000 st: $^{+1.4}_0$					
Lubrication	Not required (Non-lube)					
Mounting	Basic, Foot, Rod flange, Single clevis Double clevis, Center trunnion					
Port size	Rc1/4					
Allowable kinetic energy (J)*2	Air cushion	When activated	2.8	4.6	16	29
	When not activated	0.33	0.56	0.91	1.5	2.68

*1 No freezing

*2 Activate the air cushion when operating the cylinder. If this is not done, the piston rod assembly or the tie-rods will be damaged when the allowable kinetic energy exceeds the values shown in the above table.

Solenoid Valve Specifications

Applicable solenoid valve model	V3□08			
Coil rated voltage	Refer to the solenoid valve voltage shown below.			
Electrical entry	Grommet, DIN terminal			
Allowable voltage	-15 to 10% of the rated voltage			
Coil insulation	Class B or equivalent (130°C)			
Apparent power ^{Note)}	AC	Inrush	50 Hz	8.5 VA
		Holding	60 Hz	7.5 VA
	DC		60 Hz	50 Hz
		60 Hz		5.5 VA
Power consumption ^{Note)}	DC	6 W		

Note) At the rated voltage.

* Refer to page 1226 for solenoid valve replacement methods and part numbers.

Solenoid valve voltage

1	100 VAC (50/60 Hz)
2	200 VAC (50/60 Hz)
3	110 VAC (50/60 Hz)
4	220 VAC (50/60 Hz)
5	24 VDC
6	12 VDC
7	240 VAC (50/60 Hz)
8	48 VAC (50/60 Hz)
B	24 VAC (50/60 Hz)
P	100 VDC
V	6 VDC
Y	48 VDC
Z	110 VDC

Rod Boot Material

Symbol	Rod boot material	Maximum ambient temperature
J	Nylon tarpaulin	70°C
K	Heat resistant tarpaulin	110°C*

* Maximum ambient temperature for the rod boot itself.

Standard Strokes

Bore size	Standard stroke (mm)	
	Stroke range ①	Stroke range ②
40	25, 50, 75, 100, 125, 150, 200, 250, 300, 350, 400, 450, 500	Up to 1000
50, 63	25, 50, 75, 100, 125, 150, 200, 250, 300, 350, 400, 450, 500, 600	
80, 100	25, 50, 75, 100, 125, 150, 200, 250, 300, 350, 400, 450, 500, 600, 700	

Note 1) Intermediate strokes not listed above are produced upon receipt of order.

Note 2) Applicable strokes should be confirmed according to the usage. For details, refer to "Air Cylinders Model Selection" in the **Web Catalog**. In addition, the products that exceed the stroke range ① might not be able to fulfill the specifications due to the deflection etc.

Note 3) Please consult with SMC for manufacturability and the part numbers when exceeding the stroke range ②.

Note 4) The minimum stroke length is different in the trunnion type and types with auto switch. Refer to pages 1234 and 1235.

CV3 Series

Opening Range of Throttle Valve and Driving Speed

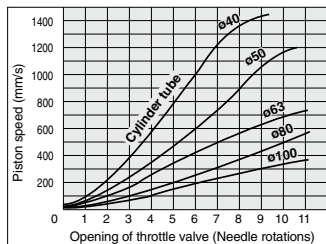

Conditions: Operating pressure 0.5 MPa, Horizontal mounting, No load, Spring return side
 • Driving speeds indicated above are for reference.

Piston Speed Adjustment

1. To slow down the piston speed, screw in the needle of the silencer exhaust throttle valve clockwise, to reduce the amount of air that is discharged.
2. The throttle valve needle opens fully when it is loosened 11 turns from its fully closed position.

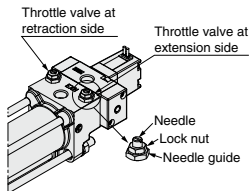

3. After the specified speed has been set, secure the needle with the lock nut.

Weight

Bore size (mm)		40	50	63	80	100
Basic weight	Basic type	1.17 (1.27)	1.47 (1.60)	2.25 (2.45)	3.96 (4.27)	5.55 (5.95)
	Axial foot type	1.34 (1.44)	1.67 (1.80)	2.54 (2.74)	4.75 (5.06)	6.48 (6.88)
	Rod side flange type	1.43 (1.53)	1.88 (2.01)	2.87 (3.07)	5.06 (5.37)	6.94 (7.34)
	Single clevis type	—	2.20 (2.33)	3.36 (3.56)	5.90 (6.21)	8.20 (8.60)
	Double clevis type	—	2.25 (2.38)	3.41 (3.61)	5.96 (6.27)	8.27 (8.67)
	Trunnion type	1.82 (1.97)	2.26 (2.35)	3.64 (4.00)	6.34 (6.79)	9.12 (9.71)
Additional weight per each 50 mm of stroke		0.20 (0.28)	0.25 (0.35)	0.31 (0.43)	0.46 (0.70)	0.58 (0.87)
Accessory bracket	Single knuckle	0.23	0.26	0.26	0.60	0.83
	Double knuckle (with pin)	0.37	0.43	0.43	0.87	1.27

Calculation: (Example) CV3L40-100-1 (*) (kg)

- Basic weight:.....1.33 (kg)
- Additional weight:.....0.20 (kg/50 st)
- Cylinder stroke:.....100 (st) $1.33 + 0.20 \times 100 = 1.73$ kg

Accessory

Mounting		Basic type	Foot type	Rod side flange type	Single clevis type	Double clevis type*	Center trunnion type
Standard equipment	Rod end nut	●	●	●	●	●	●
	Clevis pin	—	—	—	—	●	—
Option	Single knuckle joint	●	●	●	●	●	●
	Double knuckle joint* (with pin)	●	●	●	●	●	●
	With rod boot	●	●	●	●	●	●

* Pin, plain washer and cotter pin are packaged together with double clevis and double knuckle joint.

* Refer to page 1225 for dimensions and part numbers of the option.
 Refer to page 1220 for dimensions of the rod boot.

Mounting Bracket Part No.

Mounting Bracket Part No.

Bore size (mm)	40	50	63	80	100
Axial foot*	CA1-L04	CA1-L05	CA1-L06	CA1-L08	CA1-L10
Flange	CA1-F04	CA1-F05	CA1-F06	CA1-F08	CA1-F10
Single clevis	—	CV3-C05	CV3-C06	CV3-C08	CV3-C10
Double clevis**	—	CV3-D05	CV3-D06	CV3-D08	CV3-D10

* Order two foot brackets per cylinder.

** Accessories for each mounting bracket are as follows.

Foot, Flange: Body mounting bolts, Spring washer

Single clevis: Body mounting bolts, Nut, Spring washer

Double clevis: Body mounting bolts, Nut, Spring washer, Clevis pin, Flat washer, Cotter pin

Construction

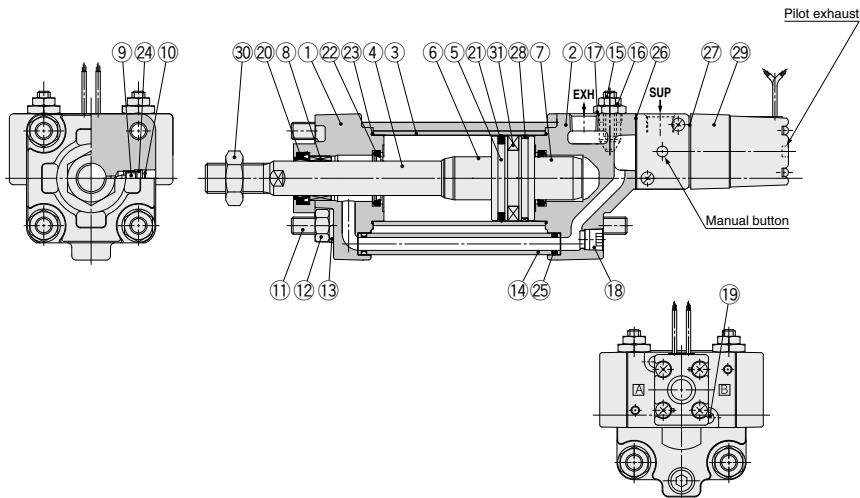

Component Parts

No.	Description	Material	Q'ty	Note
1	Rod cover	Aluminum die-casted	1	Black painted
2	Head cover	Aluminum die-casted	1	Black painted
3	Cylinder tube	Aluminum alloy	1	Hard anodized
4	Piston rod	Carbon steel	1	Hard chrome plating
5	Piston	Aluminum alloy	1	
6	Cushion ring	Aluminum alloy	1	Anodized
7	Cushion ring B	Aluminum alloy	1	Anodized
8	Bushing	Special friction material	1	
9	Cushion valve	Steel wire	2	Trivalent zinc chromated
10	Retaining ring	Spring steel	2	Phosphate coating
11	Tie-rod	Carbon steel	4	Trivalent zinc chromated
12	Tie-rod nut	Rolled steel	6	Trivalent black zinc chromated
13	Spring washer	Steel wire	6	Trivalent black zinc chromated
14	Pipe	Carbon steel tube	1	Trivalent zinc chromated
15	Needle	Free-cutting steel	2	Electroless nickel plating
16	Lock nut	Carbon steel	2	Trivalent zinc chromated
17	Needle guide	Free-cutting steel	2	Electroless nickel plating
18	Plug	Chromium molybdenum steel	1	Trivalent black zinc chromated
19	Hex. socket head cap screw with SW	Carbon steel	2	Trivalent black zinc chromated
20	Rod seal	NBR	1	
21	Piston seal	NBR	1	

No.	Description	No. of solenoids	Rod extended when energized	Rod retracted when energized
29	Solenoid valve	Single	(1)	(2)
		Double		
			(3)	

* How to order solenoid valves

Note 1) V3108-00 [Voltage] [Electrical entry]

Note 2) V3108-00 [Voltage] [Electrical entry]-X23

Note 3) V3208-00 [Voltage] [Electrical entry]

Component Parts

No.	Description	Material	Q'ty	Note
22	Cushion seal	Urethane	2	
23	Cylinder tube gasket	NBR	2	
24	Cushion valve seal	NBR	2	
25	Pipe gasket	NBR	2	
26	Head cover gasket	NBR	1	
27	Solenoid gasket	NBR	1	For single solenoid
			2	For double solenoid
28	Wear ring	Resin	1	
30	Rod end nut	Rolled steel	1	Zinc chromated
31	Magnet	—	(1)	

* Not replaceable.

Replacement Parts: Seal Kit

Bore size (mm)	Kit no.	Contents
40	CV3N40-PS	Set of nos. above 20, 21, 22, 23, 25, 26
50	CV3N50-PS	
63	CV3N63-PS	
80	CV3N80-PS	
100	CV3N100-PS	

* Seal kit includes 20, 21, 22, 23, 25, 26. Order the seal kit, based on each bore size.

(The parts indicated with number 24 is not replaceable.)

* Seal kit includes a grease pack (ø40, ø50: 10 g, ø63, ø80: 20 g, ø100: 30 g). Order with the following part number when only the grease pack is needed.

Grease pack part no.: GR-S-010 (10 g), GR-S-020 (20 g)

For the dimensions of DIN terminal, refer to page 1225.

CV3 Series

Basic Type: CV3B

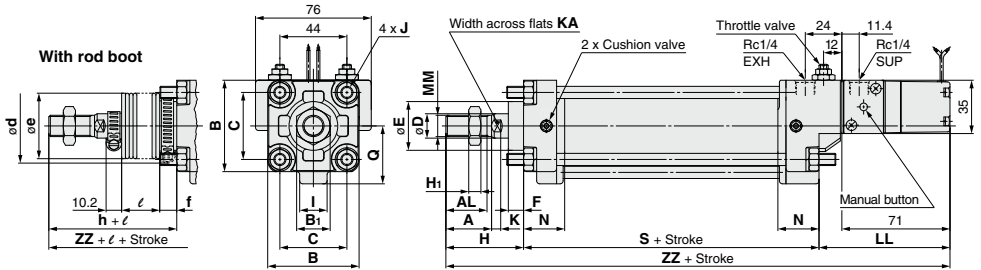

Bore size (mm)	Stroke range* (mm)	A	AL	B	B ₁	C	D	E	F	H ₁	I	J	K	KA	LL	MM	N	Q	S
40	Up to 1000	30	27	60	22	44	16	32	10	8	18	M8 x 1.25	6	14	86	M14 x 1.5	27	38	84
50	Up to 1000	35	32	70	27	52	20	40	10	11	18	M8 x 1.25	7	18	83	M18 x 1.5	30	43.5	90
63	Up to 1000	35	32	85	27	64	20	40	10	11	18	M10 x 1.25	7	18	83	M18 x 1.5	31	49	98
80	Up to 1000	40	37	102	32	78	25	52	14	13	20	M12 x 1.75	10	22	84	M22 x 1.5	37	63	116
100	Up to 1000	40	37	116	41	92	30	52	14	16	20	M12 x 1.75	10	26	85	M26 x 1.5	40	73	126

Bore size (mm)	Without rod boot	With rod boot						
	H	ZZ	d	e	f	h	ℓ	ZZ
40	51	221	56	43	11.2	59	1/4 stroke	229
50	58	231	64	52	11.2	66	1/4 stroke	239
63	58	239	64	52	11.2	66	1/4 stroke	247
80	71	271	76	65	12.5	80	1/4 stroke	280
100	72	283	76	65	14	81	1/4 stroke	292

* The minimum stroke of the one with rod boot is 20 mm or more.

Axial Foot Type: CV3L

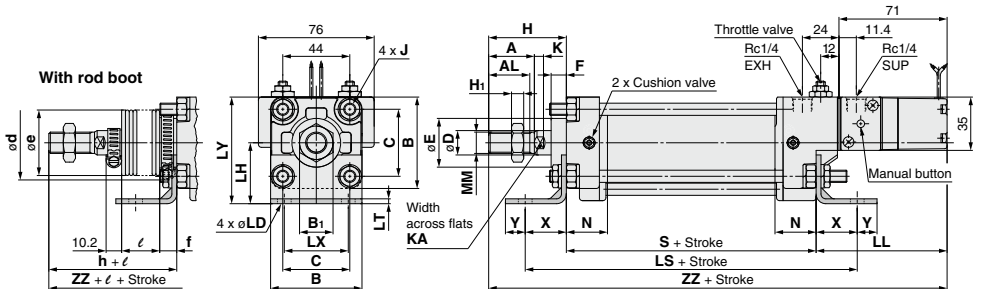

Bore size (mm)	Stroke range* (mm)	A	AL	B	B ₁	C	D	E	F	H ₁	J	K	KA	LD	LH	LL	LS	LT	LX	LY
40	Up to 1000	30	27	60	22	44	16	32	10	8	M8 x 1.25	6	14	9	40	86	138	3.2	42	70
50	Up to 1000	35	32	70	27	52	20	40	10	11	M8 x 1.25	7	18	9	45	83	144	3.2	50	80
63	Up to 1000	35	32	85	27	64	20	40	10	11	M10 x 1.25	7	18	11.5	50	83	166	3.2	59	93
80	Up to 1000	40	37	102	32	78	25	52	14	13	M12 x 1.75	10	22	13.5	65	84	204	4.5	76	116
100	Up to 1000	40	37	116	41	92	30	52	14	16	M12 x 1.75	10	26	13.5	75	85	212	6	92	133

Bore size (mm)	MM	N	S	X	Y	Without rod boot		With rod boot					
						H	ZZ	d	e	f	h	ℓ	ZZ
40	M14 x 1.5	27	84	27	13	51	221	56	43	11.2	59	1/4 stroke	229
50	M18 x 1.5	30	90	27	13	58	231	64	52	11.2	66	1/4 stroke	239
63	M18 x 1.5	31	98	34	16	58	239	64	52	11.2	66	1/4 stroke	247
80	M22 x 1.5	37	116	44	16	71	271	76	65	12.5	80	1/4 stroke	280
100	M26 x 1.5	40	126	43	17	72	283	76	65	14	81	1/4 stroke	292

The minimum stroke of the one with rod boot is 20 mm or more. * Long stroke

Rod Side Flange Type: CV3F

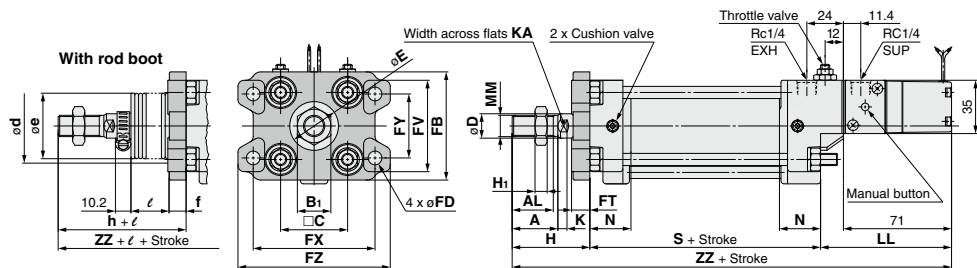

Bore size (mm)	Stroke range* (mm)	A	AL	B	B ₁	C	D	E	FB	FD	FT	FV	FX	FY	FZ	H ₁	I	J	K	KA
40	Up to 1000	30	27	60	22	44	16	32	71	9	12	60	80	42	100	8	18	M8 x 1.25	6	14
50	Up to 1000	35	32	70	27	52	20	40	81	9	12	70	90	50	110	11	18	M8 x 1.25	7	18
63	Up to 1000	35	32	85	27	64	20	40	101	11.5	15	86	105	59	130	11	18	M10 x 1.25	7	18
80	Up to 1000	40	37	102	32	78	25	52	119	13.5	18	102	130	76	160	13	20	M12 x 1.75	10	22
100	Up to 1000	40	37	116	41	92	30	52	133	13.5	18	116	150	92	180	16	20	M12 x 1.75	10	26

Bore size (mm)	LL	MM	N	Q	S	Without rod boot		With rod boot						
						H	ZZ	★d	e	f	h	ℓ	ZZ	
40	86	M14 x 1.5	27	38	84	51	221	56	43	11.2	59		1/4 stroke	229
50	83	M18 x 1.5	30	43.5	90	58	231	64	52	11.2	66		1/4 stroke	239
63	83	M18 x 1.5	31	49	98	58	239	64	52	11.2	66		1/4 stroke	247
80	84	M22 x 1.5	37	63	116	71	271	76	65	12.5	80		1/4 stroke	280
100	85	M26 x 1.5	40	73	126	72	283	76	65	14	81		1/4 stroke	292

* The minimum stroke of the one with rod boot is 20 mm or more. ★ When drilling holes to get through the rod boot for the purpose of mounting, make the holes larger than the outer diameter (ød) of the rod boot mounting bracket.

** Long stroke

Double Clevis Type: CV3D

Bore size $\phi 40$ is not available.

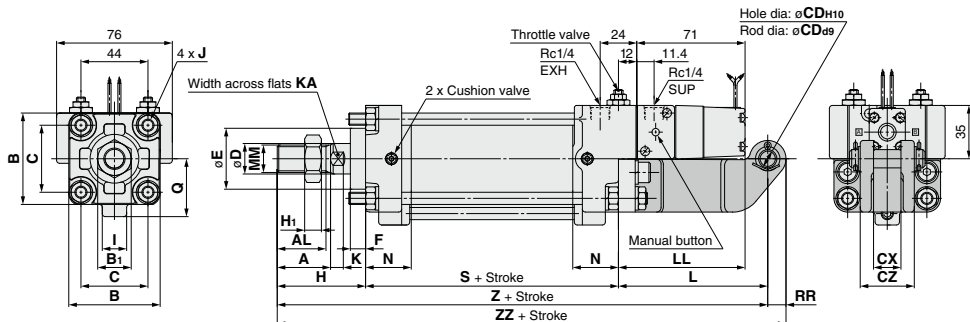

With rod boot

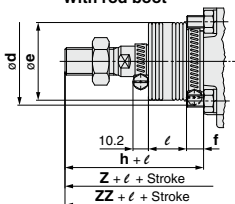

** Bore size $\phi 40$ is not available.

(mm)

Bore size** (mm)	Stroke range* (mm)	A	AL	B	B ₁	C	CD	CX	CZ	D	E	F	H ₁	I	J	K	KA	L
50	Up to 1000	35	32	70	27	52	12	18 ^{+0.3} _{-0.1}	35.5	20	40	10	11	18	M8 x 1.25	7	18	98
63	Up to 1000	35	32	85	27	64	16	25 ^{+0.3} _{-0.1}	50	20	40	10	11	18	M10 x 1.25	7	18	100
80	Up to 1000	40	37	102	32	78	20	31.5 ^{+0.3} _{-0.1}	63	25	52	14	13	20	M12 x 1.75	10	22	105
100	Up to 1000	40	37	116	41	92	25	35.5 ^{+0.3} _{-0.1}	71	30	52	14	16	20	M12 x 1.75	10	26	110

Bore size** (mm)	LL	MM	N	Q	RR	S	Without rod boot			With rod boot					
							H	Z	ZZ	d	e	f	h	ℓ	ZZ
50	83	M18 x 1.5	30	43.5	12	90	58	246	258	64	52	11.2	66	1/4 stroke	266
63	83	M18 x 1.5	31	49	16	98	58	256	272	64	52	11.2	66	1/4 stroke	280
80	84	M22 x 1.5	37	63	20	116	71	292	312	76	65	12.5	80	1/4 stroke	321
100	85	M26 x 1.5	40	73	25	126	72	308	333	76	65	14	81	1/4 stroke	342

* Clevis pin, flat washer and cotter pin are shipped together. The minimum stroke with rod boot is 20 mm or more.

CV3 Series

Center Trunnion Type: CV3T

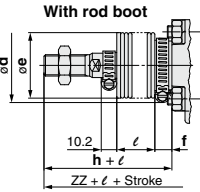
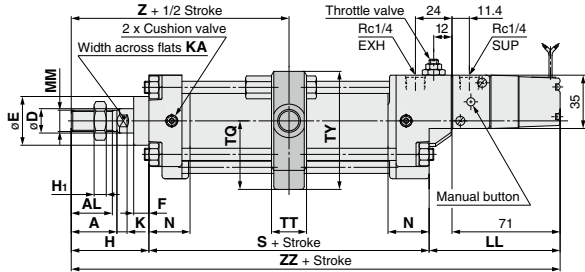
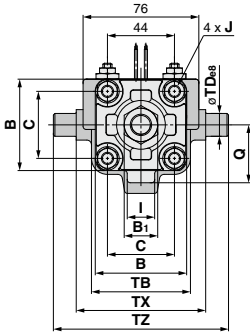

Bore size (mm)	Stroke range* (mm)	A	AL	B	B ₁	C	D	E	F	H ₁	I	J	K	KA	LL	MM	N	Q
40	25 to 1000	30	27	60	22	44	16	32	10	8	18	M8 x 1.25	6	14	86	M14 x 1.5	27	38
50	25 to 1000	35	32	70	27	52	20	40	10	11	18	M8 x 1.25	7	18	83	M18 x 1.5	30	43.5
63	50 to 1000	35	32	85	27	64	20	40	10	11	18	M10 x 1.25	7	18	83	M18 x 1.5	31	49
80	50 to 1000	40	37	102	32	78	25	52	14	13	20	M12 x 1.75	10	22	84	M22 x 1.5	37	63
100	50 to 1000	40	37	116	41	92	30	52	14	16	20	M12 x 1.75	10	26	85	M26 x 1.5	40	73

(mm)

Bore size (mm)	S	TB	ϕTD_{88}	TI	TQ	TT	TX	TY	TZ	Without rod boot			With rod boot					
										H	Z	ZZ	d	e	f	h	ℓ	ZZ
40	84	65	15 ^{-0.032} _{-0.039}	20	45	23	85	77.5	115	51	93	221	56	43	11.2	59	1/4 stroke	229
50	90	75	15 ^{-0.032} _{-0.039}	20	50	23	95	87.5	125	58	103	231	64	52	11.2	66	1/4 stroke	239
63	98	90	18 ^{-0.032} _{-0.039}	20	57	28	110	102	146	58	107	239	64	52	11.2	66	1/4 stroke	247
80	116	110	25 ^{-0.040} _{-0.073}	24	69.5	35	140	124.5	190	71	129	271	76	65	12.5	80	1/4 stroke	280
100	126	130	25 ^{-0.040} _{-0.073}	24	79.5	43	162	144.5	212	72	135	283	76	65	14	81	1/4 stroke	292

* The minimum stroke of the one with rod boot is 20 mm or more.

Electrical Entry: Dimensions for DIN Terminal

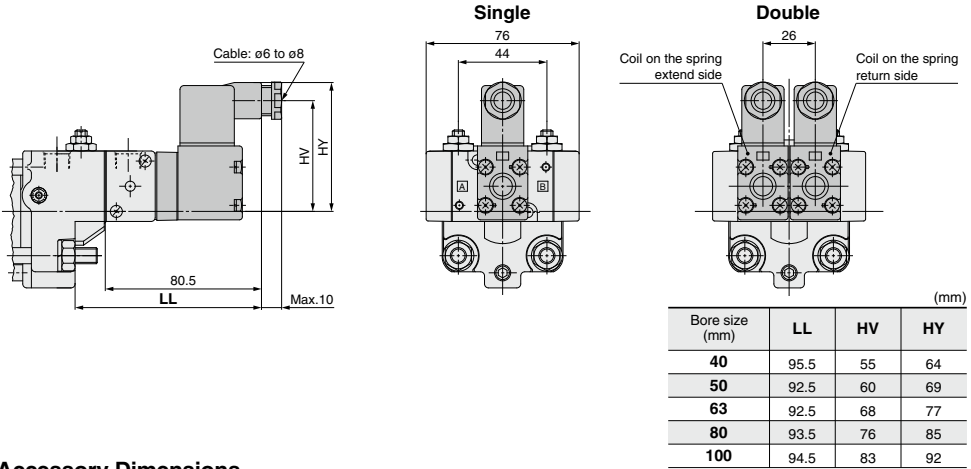

Accessory Dimensions

I Type Single Knuckle Joint

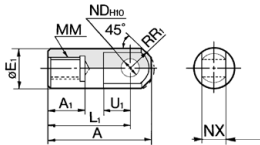

Material: Free cutting sulfur steel (mm)

Part no.	Applicable bore size (mm)	A	A ₁	øE _i	L ₁	MM	R ₁	U ₁	øND _{H10}	NX
I-04	40	69	22	24	55	M14 x 1.5	15.5	20	12 ^{+0.070} ₀	16 ^{-0.1} _{-0.2}
I-05	50, 63	74	27	28	60	M18 x 1.5	15.5	20	12 ^{+0.070} ₀	16 ^{-0.1} _{-0.2}
I-08	80	91	37	36	71	M22 x 1.5	22.5	26	18 ^{+0.070} ₀	28 ^{-0.1} _{-0.3}
I-10	100	105	37	40	83	M26 x 1.5	24.5	28	20 ^{+0.084} ₀	30 ^{-0.1} _{-0.2}

Y Type Double Knuckle Joint

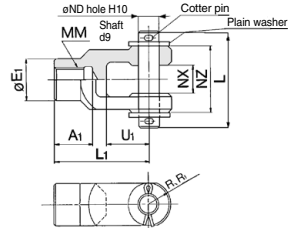

Material: Cast iron (mm)

Part no.	Applicable bore size (mm)	A ₁	E ₁	L ₁	MM	R ₁	U ₁	ND	NX	NZ	L	Cotter pin size	Plain washer size
Y-04D	40	22	24	55	M14 x 1.5	13	25	12	16 ^{+0.3} _{0.1}	38	55.5	ø3 x 18 L	Polished round 12
Y-05D	50, 63	27	28	60	M18 x 1.5	15	27	12	16 ^{+0.3} _{0.1}	38	55.5	ø3 x 18 L	Polished round 12
Y-08D	80	37	36	71	M22 x 1.5	19	28	18	28 ^{+0.3} _{0.1}	55	76.5	ø4 x 25 L	Polished round 18
Y-10D	100	37	40	83	M26 x 1.5	21	38	20	30 ^{+0.3} _{0.1}	61	83	ø4 x 30 L	Polished round 20

* Knuckle pin, cotter pin, and plain washer are shipped together.

Clevis Pin

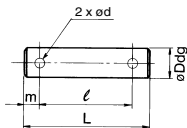

Material: Carbon steel (mm)

Part no.	Applicable bore size (mm)	øDd9	L	ød	ℓ	Applicable plain washer	Applicable cotter pin
CDP-3A	50	12 ^{+0.060} _{-0.090}	55.5	3	47.5	4.0	3 x 18
CVD-06	63	16 ^{+0.060} _{-0.090}	75	4	65	5.0	Polished round 12
CVD-08	80	20 ^{+0.060} _{-0.117}	94	5	79	7.5	Polished round 16
CVD-10	100	25 ^{+0.060} _{-0.117}	105	5	90	7.5	Polished round 20
							5 x 35

* Cotter pins and flat washers are included.

Knuckle Pin

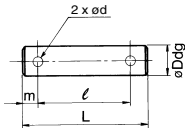

Material: Carbon steel (mm)

Part no.	Applicable bore size (mm)	øDd9	L	ℓ	m	ød (Dritl through)	Applicable cotter pin	Applicable plain washer
CDP-3A	40, 50, 63	12 ^{-0.060} _{-0.090}	55.5	47.5	4	3	ø3 x 18 L	Polished round 12
CDP-5A	80	18 ^{-0.060} _{-0.090}	76.5	66.5	5	4	ø4 x 25 L	Polished round 16
CDP-6A	100	20 ^{-0.060} _{-0.117}	83	73	5	4	ø4 x 30 L	Polished round 20

* Cotter pins and flat washers are included.

Rod End Nut

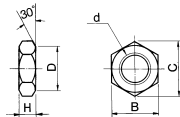

Material: Rolled steel (mm)

Part no.	Applicable bore size (mm)	d	H	B	C	D
NT-04	40	M14 x 1.5	8	22	25.4	21
NT-05	50, 63	M18 x 1.5	11	27	31.2	26
NT-08	80	M22 x 1.5	13	32	37	31
NT-10	100	M26 x 1.5	16	41	47.3	39

CV3 Series

Manual Operation

Manual operation (non-locking) is possible by pushing the manual button about 3 mm.

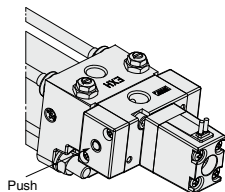

Solenoid Valve Replacement and Order No.

(Single solenoid)

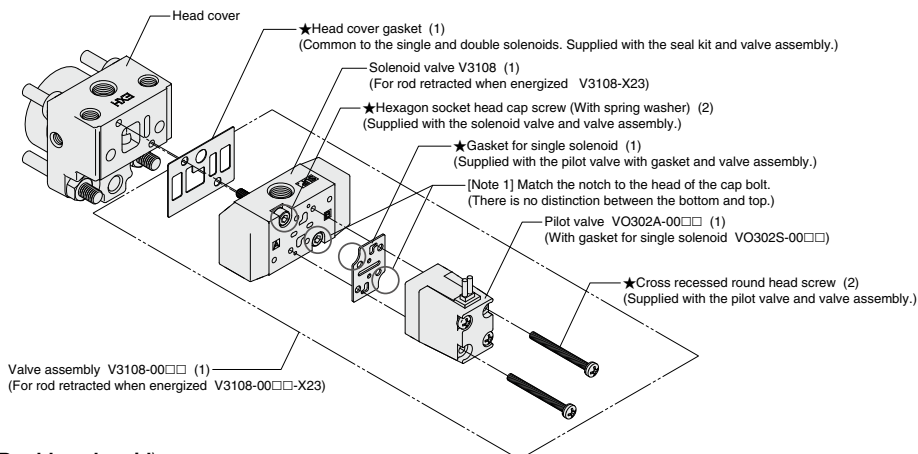

(Double solenoid)

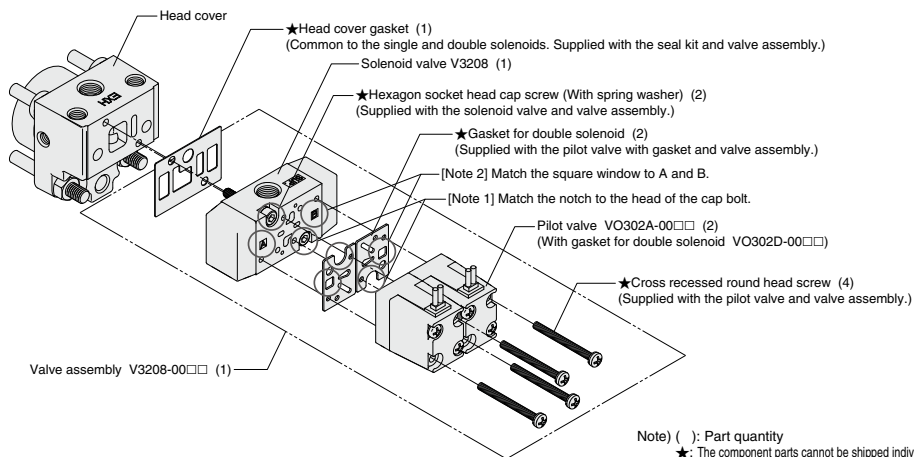

Note) () : Part quantity

★: The component parts cannot be shipped individually.



CV3 Series Specific Product Precautions

Be sure to read this before handling the products. Refer to page 9 for safety instructions, pages 10 to 19 for actuator and auto switch precautions, and 3/4/5-port solenoid valve precautions on the SMC website: <https://www.smcworld.com>

Handling

⚠ Caution

1. **Do not open the cushion valve beyond the stopper.**
A retaining ring is installed as a cushion valve retention mechanism. Do not open the cushion valve beyond it. If not operated in accordance with the above precautions, the cushion valve may be ejected from the cover when air pressure is supplied.

Bore size (mm)	Width across flats	Socket wrench
40, 50	2.5	JIS 4648 Hexagonal wrench key 2.5
63, 80, 100	4	JIS 4648 Hexagonal wrench key 4

2. **Use the air cushion at the end of cylinder stroke.**
Otherwise, the tie-rod or piston rod assembly will be damaged.

⚠ Caution

1. **Do not use a pneumatic type as an air-hydro cylinder. It can cause oil leak.**
2. **Do not rotate the piston rod when the rod boot is fixed.**
Before rotating the piston rod, loosen the band to avoid twisting the rod boot.
3. **Install the rod boot with the breathing hole facing downwards or in a direction suitable to prevent dust, moisture etc. from entering easily into the rod boot.**

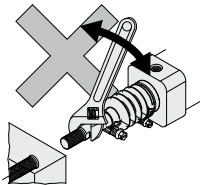

Selection

⚠ Warning

1. **Confirm the specifications.**
Products in this catalog are designed to be used for compressed air systems. If not operated within the designated pressure or temperature, it may damage the products or cause malfunction. (Refer to specifications.)
2. **Energizing continuously for a long period of time**
When the valve is continuously energized for a long period of time, the performance may deteriorate or effect peripheral equipment adversely since temperature rises when coils generate heat.

Disassembly/Replacement

⚠ Caution

1. **Use a socket wrench when the bracket is replaced.**
If other tools are used, the nut or other parts may be deformed or the work efficiency may decrease. For applicable sockets, refer to the table below.

Bore size (mm)	Nut	Width across flats	Socket	Tightening torque (N·m)
40, 50	DA00180	13	JIS B4636	7.4
	(M8 x 1.25, Hexagon nut 3 types)		+ Two-angle socket 13	
63	DA00008	17	JIS B4636	20
	(M10 x 1.25, Hexagon nut 3 types)		+ Two-angle socket 17	
80, 100	DA00013	19	JIS B4636	29
	(M12 x 1.75, Hexagon nut 3 types)		+ Two-angle socket 19	

2. **Do not replace the bushing.**
As the bushing is press-fit, replace the cover assembly when the bushing must be replaced.
3. **When a seal is replaced, apply grease to the new seal before it is assembled.**
Operation of the cylinder without greasing will result in extreme abrasion of the seal, causing premature air leakage.
4. **Do not disassemble the trunnion type cylinder because the mounting precision is required.**
It is difficult to align the axial center of the trunnion with the axial center of the cylinder. Thus, if this type of cylinder is disassembled and reassembled, the required dimensional accuracy cannot be attained, which may lead to malfunctions.

Valve Mounted Cylinder: Non-rotating Rod Type

Double Acting

CV3K Series

ø40, ø50, ø63

How to Order

Built-in Magnet Cylinder Model

If a built-in magnet cylinder without an auto switch is required, there is no need to enter the symbol for the auto switch.
(Example) CDV3KL40-100-1

		Suffix for cylinder	
Rod boot	J	Nylon tarpaulin	
	K	Heat resistant tarpaulin	
Cushion	N	Without cushion	
	R	With cushion on rod end	
	H	With cushion on head end	
	Nil	With cushion on both ends	

* When specifying symbol more than one, combine symbols alphabetically.

Solenoid valve	
Nil	2 position single
W	2 position double

Made to Order
Refer to page 1229 for details.

Solenoid valve voltage
Refer to page 1229 for solenoid valve voltage.

Cylinder stroke (mm)
Refer to page 1229 for standard strokes.

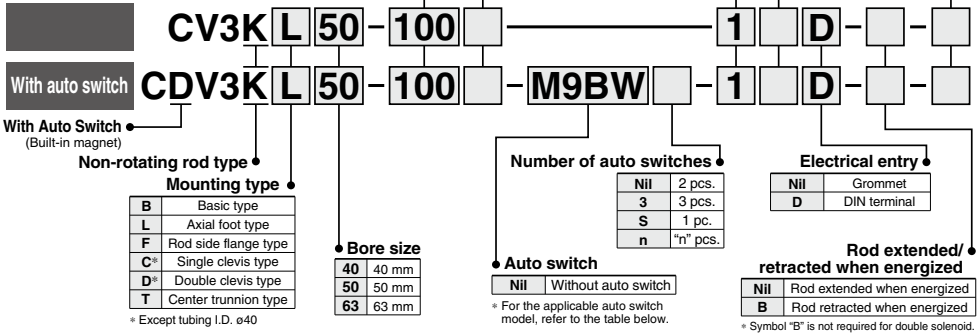

Applicable Auto Switches

Refer to pages 1341 to 1435 for further information on auto switches.

Type	Special function	Electrical entry	Wiring (Output)	Load voltage		Auto switch model		Lead wire length (m)					Pre-wired connector	Applicable load			
				DC	AC	Tie-rod mounting	Band mounting	0.5 (Nil)	1 (M)	3 (L)	5 (Z)						
Solid state auto switch	—	Grommet	3-wire (NPN)	24 V	5 V, 12 V	—	M9N	●	●	●	○	○	—	IC circuit			
			3-wire (PNP)				G59**	●	●	●	○	○					
		Terminal conduit	2-wire	12 V	M9P	●	●	●	○	○	—	—					
			3-wire (NPN)		G5P**	●	●	●	○	○							
		Diagnostic indication (2-color indicator)	Grommet	2-wire	12 V	12 V	—	M9B	●	●	●	○	○	—	—		
				3-wire (NPN)				K59**	●	●	●	○	○				
	Terminal conduit		2-wire	12 V	12 V	—	—	G39C	●	●	●	○	○	—	—		
			3-wire (PNP)					G39	●	●	●	○	○				
	Water resistant (2-color indicator)		Grommet	2-wire	12 V	12 V	—	K39C	●	●	●	○	○	—	—		
				3-wire (NPN)				M9NW	●	●	●	○	○				
	With diagnostic output (2-color indicator)	Terminal conduit	2-wire	12 V	12 V	—	M9PW	●	●	●	○	○	—	—			
			3-wire (PNP)				G59W**	●	●	●	○	○					
Reed auto switch	—	Grommet	2-wire	24 V	12 V	—	M9BW	●	●	●	○	○	—	—			
			3-wire (NPN)				K59W**	●	●	●	○	○					
		Terminal conduit	2-wire	12 V	12 V	—	—	M9NA ^{†1}	○	○	○	○	○	—	—		
			3-wire (PNP)					M9PA ^{†1}	○	○	○	○	○				
		Diagnostic indication (2-color indicator)	DIN terminal	2-wire	12 V	12 V	—	M9BA ^{†1}	○	○	○	○	○	—	—		
				4-wire (NPN)				F59F	●	●	●	○	○				
	With diagnostic output (2-color indicator)	Grommet	2-wire (NPN equivalent)	24 V	12 V	—	A96	●	●	●	○	○	—	—			
			100 V				A93	●	●	●	○	○					
		Terminal conduit	2-wire	12 V	12 V	—	—	100 V or less	A90	●	●	●	○	○	—	—	
			100 V, 200 V					A54	●	●	●	○	○				
		Diagnostic indication (2-color indicator)	Grommet	2-wire	24 V	12 V	—	—	200 V or less	A64	●	●	●	○	○	—	—
				100 V, 200 V					A33C	●	●	●	○	○			
Water resistant (2-color indicator)	Terminal conduit	2-wire	24 V	12 V	—	—	A64	●	●	●	○	○	—	—			
		3-wire (NPN)					A34C	●	●	●	○	○					
With diagnostic output (2-color indicator)	DIN terminal	2-wire	24 V	12 V	—	—	A44C	●	●	●	○	○	—	—			
		4-wire (NPN)					A44	●	●	●	○	○					
Water resistant (2-color indicator)	Grommet	2-wire	24 V	12 V	—	—	A59W	●	●	●	○	○	—	—			
		3-wire (NPN equivalent)					B59W**	●	●	●	○	○					

*1 Water resistant type auto switches can be mounted on the above models, but in such case SMC cannot guarantee water resistance.

*2 The load voltage used is 24 VDC.

* Lead wire length symbols: 0.5 m..... Nil (Example) M9NW
1 m..... M (Example) M9MW
3 m..... L (Example) M9NL
5 m..... Z (Example) M9NZ

* Auto switches marked with "C" are produced upon receipt of order.

**D-B5C/B64/B5/K5C types are mountable only upon a receipt of order.
(Not mountable after the time of shipment)

* Since there are other applicable auto switches than listed, refer to page 1236 for details.

* For details about auto switches with pre-wired connector, refer to pages 1410 and 1411.

* D-A9□/M9□/M9□/W9□/A auto switches are shipped together (not assembled). (Only auto switch mounting brackets are assembled before shipped.)

Adjustable speed.

Built-in throttle valves are provided to enable speed adjustments in each direction.

A manual operation mechanism is provided as standard equipment (non-locking).

An auto switch cylinder with the switch installed can also be manufactured.



Symbol
Air cushion

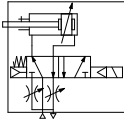

Made to Order Specifications
[Click here for details](#)

Symbol	Specifications
-XA□	Change of rod end shape
-XC15	Change of tie-rod length

Refer to pages 1232 to 1236 for cylinders with auto switches.

- Proper auto switch mounting position (detection at stroke end) and mounting height
- Minimum auto switch mounting stroke
- Operating range
- Auto switch mounting bracket: Part no.

Specifications

Bore size (mm)		40	50	63	
Fluid		Air			
Proof pressure		1.35 MPa			
Maximum operating pressure		0.9 MPa			
Minimum operating pressure		0.15 MPa			
Ambient and fluid temperature		-10 to 50°C			
Piston speed		50 to 500 mm/s			
Cushion		Air cushion			
Stroke length tolerance		Up to 250 st: $^{+1.0}_0$, 251 to 600 st: $^{+1.4}_0$			
Rod non-rotating accuracy		$\pm 0.8^\circ$			
Allowable rotational torque		0.44 N·m or less			
Lubrication		Not required (Non-lube)			
Mounting		Basic, Axial foot, Rod flange, Single clevis Double clevis, Center trunnion			
Allowable kinetic energy (J)	Air cushion	When activated	2.8	4.6	7.8
		When not activated	0.33	0.56	0.91

* No freezing

Solenoid Valve Specifications

Applicable solenoid valve model		V3□08	
Coil rated voltage		Refer to the solenoid valve voltage shown below.	
Electrical entry		Grommet, DIN terminal	
Allowable voltage		-15 to 10% of the rated voltage	
Coil insulation		Class B or equivalent (130°C)	
Apparent power ^{Note)}	AC	Inrush	50 Hz 8.5 VA
		60 Hz 7.5 VA	
	Holding	50 Hz 7.0 VA	
		60 Hz 5.5 VA	
Power consumption ^{Note)}	DC	6 W	

Note) At the rated voltage.

Solenoid valve voltage

1	100 VAC (50/60 Hz)
2	200 VAC (50/60 Hz)
3	110 VAC (50/60 Hz)
4	220 VAC (50/60 Hz)
5	24 VDC
6	12 VDC
7	240 VAC (50/60 Hz)
8	48 VAC (50/60 Hz)
B	24 VAC (50/60 Hz)
P	100 VDC
V	6 VDC
Y	48 VDC
Z	110 VDC

Rod Boot Material

Symbol	Rod boot material	Max. ambient temperature
J	Nylon tarpaulin	70°C
K	Heat resistant tarpaulin	110°C*

* Maximum ambient temperature for the rod boot itself.

Standard Stroke

Bore size (mm)	Standard stroke (mm)
40	25, 50, 75, 100, 125, 150, 200, 250, 300, 350, 400, 450, 500*
50, 63	25, 50, 75, 100, 125, 150, 200, 250, 300, 350, 400, 450, 500, 600*

Note) The cylinders with the standard strokes indicated above can be delivered in a short term. Intermediate stroke except mentioned above is manufactured upon receipt of order.

- When the auto switch is attached, the minimum stroke is going to be different. Refer to pages 1234 and 1235.

The minimum stroke length is different in the trunnion type. Refer to pages 1234 and 1235 for further information.

Please consult with SMC for longer strokes than the strokes marked with *.

CV3K Series

Opening Range of Throttle Valve and Driving Speed

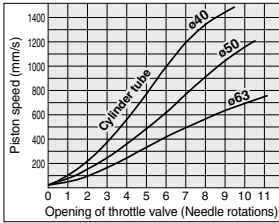

Conditions: Operating pressure 0.5 MPa, Horizontal mounting, No load, Spring return side
 • The speeds shown in the graph are for reference.

Weight

Bore size (mm)		40	50	63
Basic weight	Basic type	1.20	1.52	2.36
	Axial foot type	1.37	1.72	2.65
	Rod side flange type	1.46	1.93	2.98
	Single clevis type	—	2.25	3.47
	Double clevis type	—	2.30	3.52
	Trunnion type	1.85	2.31	3.75
Additional weight per each 50 mm of stroke		0.20	0.25	0.31
Accessory bracket	Single knuckle	0.23	0.26	0.26
	Double knuckle (with pin)	0.37	0.43	0.43

Calculation: (Example) CV3KL40-100-1

- Basic weight.....1.36 (kg)
- Additional weight.....0.20 (kg/50 st)
- Cylinder stroke.....100 (st) $1.36 + 0.20 \times 100 \div 50 = 1.76$ kg

Accessory

Mounting		Basic type	Foot type	Rod side flange type	Single clevis type	Double * clevis type	Center trunnion type
Standard equipment	Rod end nut	●	●	●	●	●	●
	Clevis pin	—	—	—	—	●	—
Option	Single knuckle joint	●	●	●	●	●	●
	Double knuckle joint* (with pin)	●	●	●	●	●	●
	With rod boot	●	●	●	●	●	●

- * Pin, plain washer and cotter pin are shipped together with double clevis and double knuckle joint.
- * Refer to page 1225 for dimensions and part numbers of the option.
- Refer to page 1231 for dimensions of the rod boot.

Handling

1. Adjusting of the piston speed
2. Change of voltage specifications
3. Manual operation
4. Changing between rod extended when energized and rod retracted when energized.

Since the operations above 1. to 4. are the same as the CV3 series, refer to pages 1218 and 1226.

⚠ Precautions

Be sure to read this before handling the products. Refer to page 9 for safety instructions and pages 1126 to 1128 for common precautions.

Operating Precautions

⚠ Caution

1. Avoid using the air cylinder in such a way that rotational torque would be applied to the piston rod.

If rotational torque is applied, the non-rotating guide will become deformed, causing a loss of non-rotating accuracy. Also, to screw a bracket or a nut onto the threaded portion at the end of the piston rod, make sure the retract the piston rod entirely, and place a wrench on the parallel sections of the rod that protrudes. To tighten, take precautions to prevent the tightening torque from being applied to the non-rotating guide.

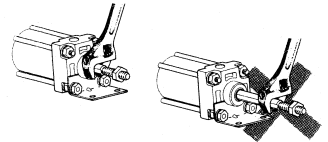

Disassembly/Replacement

⚠ Caution

1. When replacing the rod seal, be sure to follow the seal replacement procedure. Depending on the position in which the rod seal is fitted, air leakage may occur. Therefore, be sure to follow the seal replacement procedure when replacing the seal.
2. Do not replace the non-rotating guide. Since the non-rotating guide is press fitted, the entire cover assembly needs to be replaced instead of a single part.

Selection

⚠ Warning

1. Confirm the specifications. Products in this catalog are designed to be used for compressed air systems. If not operated within the designated pressure or temperature, it may damage the products or cause malfunction. (Refer to specifications.)
2. Energizing continuously for a long period of time
 When the valve is continuously energized for a long period of time, the performance may deteriorate or effect peripheral equipment adversely since temperature rises when coils generate heat.

Valve Mounted Cylinder: Non-rotating Rod Type Double Acting **CV3K Series**

Construction

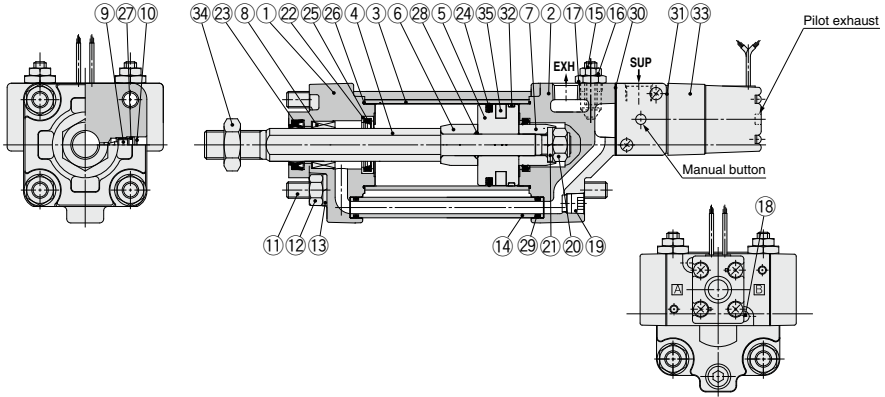

Component Parts

No.	Description	Material	Qty	Note
1	Rod cover	Aluminum die-casted	1	Black painted
2	Head cover	Aluminum die-casted	1	Black painted
3	Cylinder tube	Aluminum alloy	1	Hard anodized
4	Piston rod	Carbon steel	1	Hard chrome plated
5	Piston	Aluminum alloy	1	Trivalent zinc chromated
6	Cushion ring A	Rolled steel	1	Trivalent zinc chromated
7	Cushion ring B	Rolled steel	1	Trivalent zinc chromated
8	Non-rotating guide	Special friction material	1	
9	Cushion valve	Steel wire	2	Trivalent zinc chromated
10	Retaining ring	Spring steel	2	Phosphate coating
11	Tie-rod	Carbon steel	4	Trivalent zinc chromated
12	Tie-rod nut	Rolled steel	6	Trivalent black zinc chromated
13	Spring washer	Steel wire	6	Trivalent black zinc chromated
14	Pipe	Carbon steel tube	1	Trivalent zinc chromated
15	Needle	Free-cutting steel	2	Electroless nickel plated
16	Lock nut	Carbon steel	2	Trivalent zinc chromated
17	Needle guide	Free-cutting steel	2	Electroless nickel plated
18	Hex. socket head cap screw with SW	Carbon steel	2	Trivalent black zinc chromated

No.	Description	Material	Qty	Note
19	Plug	Chromium molybdenum steel	1	Trivalent black zinc chromated
20	Piston nut	Rolled steel	1	
21	Spring washer	Steel wire	1	
22	Cushion seal holder	Aluminum alloy	1	
23	Rod seal	NBR	1	
24	Piston seal	NBR	1	
25	Cushion seal	Urethane	2	
26	Cylinder tube gasket	NBR	2	
27*	Cushion valve seal	NBR	2	
28*	Piston gasket	NBR	1	
29	Pipe gasket	NBR	2	
30	Head cover gasket	NBR	1	
31	Solenoid gasket	NBR	1	For single solenoid
32	Wear ring	Resin	1	For double solenoid
33	Solenoid valve	—	1	
34	Rod end nut	Rolled steel	1	Zinc chromated
35	Magnet	—	(1)	

* Not replaceable.

Replacement Parts: Seal Kit

Bore size (mm)	Kit no.	Contents
40	CV3K40-PS	Set of nos. above
50	CV3K50-PS	23, 24, 25,
63	CV3K63-PS	26, 29, 30

* Seal kit includes 23, 24, 25, 26, 29, 30. Order the seal kit, based on each bore size. (The parts indicated with numbers 27 and 28 are not replaceable.)

* Seal kit includes a grease pack (ø40, ø50: 10 g, ø63 or more: 20 g). Order with the following part number when only the grease pack is needed.

Grease pack part no.: GR-S-010 (10 g),
GR-S-020 (20 g)

Basic Type: CV3KB□

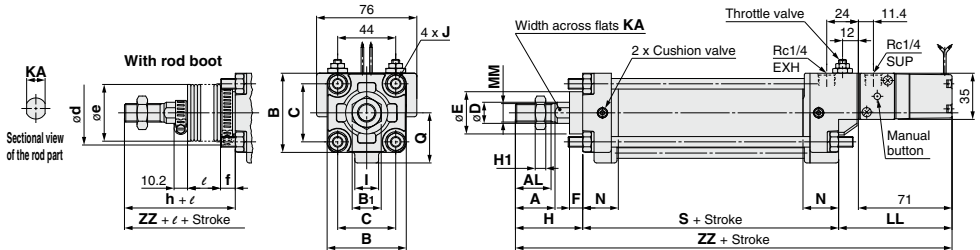

Bore size (mm)	Stroke range* (mm)	A	AL	B	B ₁	C	D	E	F	H ₁	I	J	KA	LL	MM	N	Q	S
40	Up to 500	30	27	60	22	44	16	32	10	8	18	M8 x 1.25	14	86	M14 x 1.5	27	38	84
50	Up to 600	35	32	70	27	52	20	40	10	11	18	M8 x 1.25	18	83	M18 x 1.5	30	43.5	90
63	Up to 600	35	32	85	27	64	20	40	10	11	18	M10 x 1.25	18	83	M18 x 1.5	31	49	98

Bore size (mm)	Without rod boot		With rod boot					
	H	ZZ	d	e	f	h	i	ZZ
40	51	221	56	43	11.2	59	1/4 stroke	229
50	58	231	64	52	11.2	66	1/4 stroke	239
63	58	239	64	52	11.2	66	1/4 stroke	247

* The minimum stroke of the one with rod boot is 20 mm or more.
** For dimensions of DIN terminal, refer to page 1225.

- External dimensions of each mounting bracket other than basic type are the same, except KA dimension. Refer to pages 1220 to 1225.
- For accessory, refer to page 1225.

Auto Switch Mounting

Auto Switch Proper Mounting Position (Detection at Stroke End) and Its Mounting Height

<Band mounting type>

D-B5□/B64/B59W

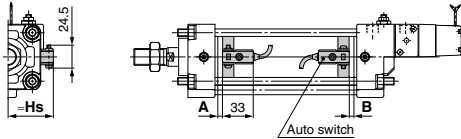

D-A3□
D-G39/K39

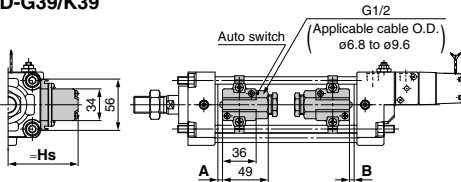

D-G5□/K59
D-G5□W/K59W
D-G59F/G5NT

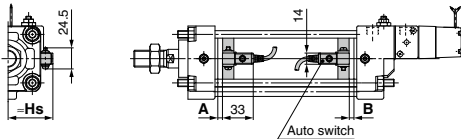

D-A44

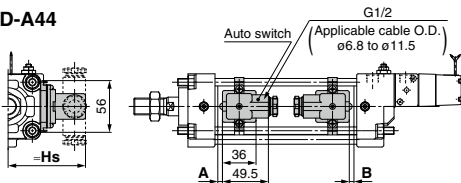

<Tie-rod mounting type>

D-A9□/A9□V

D-M9□/M9□V

D-M9□W/M9□WV

D-M9□A/M9□AV

D-Z7□/Z80

D-Y59□/Y69□/Y7P/Y7PV

D-Y7□W/Y7□WV

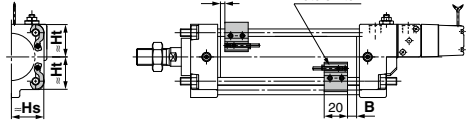

D-A5□/A6□
D-A59W

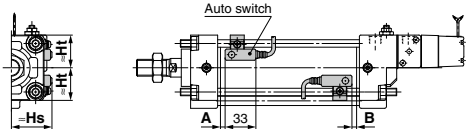

D-A3□C
D-G39C/K39C

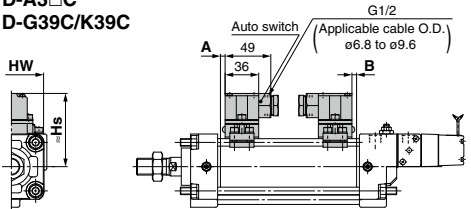

D-F5□/J59

D-F5NT

D-F5□W/J59W

D-F59F

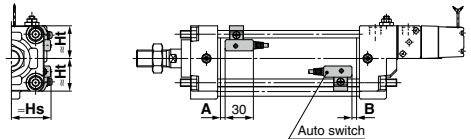

D-A44C

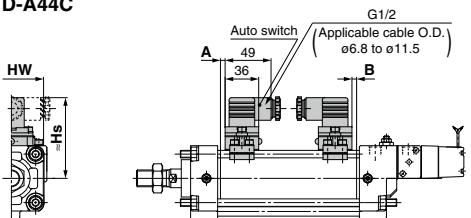

Auto Switch Proper Mounting Position (Detection at Stroke End) and Its Mounting Height

Auto Switch Proper Mounting Position

(mm)

Auto switch model	D-M9□ D-M9□V D-M9□W D-M9□WV D-M9□A D-M9□AV		D-A9□ D-A9□V		D-Y59□ D-Y69□ D-Y7P D-Y7PV D-Y7□W D-Y7□WV D-Y7BA D-B59W D-Z7□ D-Z80		D-G39 D-G39C D-K39 D-K39C D-A5□ D-A6□ D-A3□ D-A3□C D-A44 D-A44C		D-G5□ D-K59 D-G5NT D-G5□W D-K59W D-G5BA D-G59F		D-B5□ D-B64		D-F5□ D-J59 D-F59F D-F5□W D-J59W D-F5BA		D-F5NT		D-A59W	
	A	B	A	B	A	B	A	B	A	B	A	B	A	B	A	B	A	B
40	10	8	6	4	3.5	1.5	0	0	2	0	0.5	0	6.5	4.5	11.5	9.5	4	2
50	10	8	—	—	3.5	1.5	0	0	2	0	0.5	0	6.5	4.5	11.5	9.5	4	2
63	12.5	11.5	8.5	7.5	6	5	2.5	1.5	4.5	3.5	3	2	9	8	14	13	6.5	5.5
80	16	14	12	10	9.5	7.5	6	4	8	6	6.5	4.5	12.5	10.5	17.5	15.5	10	8
100	17.5	16.5	13.5	12.5	11	10	7.5	6.5	9.5	8.5	8	7	14	13	19	18	11.5	10.5

Note 1) D-B5□, D-G5□ and D-K5□ types are mountable only upon a receipt of order. (Not mountable after the time of shipment)

Note 2) D-A9□ and D-A9□V types cannot be mounted on ø50

Note 3) Adjust the auto switch after confirming the operating conditions in the actual setting.

Auto Switch Mounting Height

(mm)

Auto switch model	D-M9□ D-M9□W D-M9□A D-A9□		D-M9□V D-M9□WV D-M9□AV		D-A9□V		D-Y59□ D-Y7P D-Y7□W D-Y7BA D-Z7□ D-Z80		D-Y69□ D-Y7PV D-Y7□WV		D-G5□ D-K59 D-G5□W D-K59W D-G59F D-G5BA D-G5NT D-B5□ D-B64 D-B59W		D-G39 D-K39 D-A3□		D-A44		D-J59 D-F5□W D-J59W D-F59F D-F5BA D-F5NT		D-A5□ D-A6□ D-A59W		D-G39C D-K39C D-A3□C		D-A44C	
	Hs	Ht	Hs	Ht	Hs	Ht	Hs	Ht	Hs	Ht	Hs	Ht	Hs	Ht	Hs	Ht	Hs	Ht	Hs	Ht	Hs	Ht	Hs	Ht
40	30	30	34	30	31	30	30	30	30	30	30	37	71.5	81.5	38	31.5	38.5	31.5	73	69	81	69		
50	34	34	38	34	—	—	34	34	34	34	34	42	76.5	86.5	42	35.5	42	35.5	78.5	77	86.5	77		
63	41	41	44	41	41.5	41	41	41	41	41	41	49	83.5	93	47	43	46.5	43	85.5	91	93.5	91		
80	49.5	49	52.5	49	50	49	49.5	49	49.5	49	49.5	57.5	92	102	53.5	51	53.5	51	94	107	102	107		
100	56.5	56	61	56	58.5	56	58.5	55.5	57.5	55.5	68	102.5	112.5	61	57.5	61.5	57.5	104	121	112	121			

* D-A9□ and D-A9□V types cannot be mounted on ø50

CV3 Series

Minimum Stroke For Auto Switch Mounting

		n: Number of auto switches (mm)					
Auto switch model	No. of auto switches mounted	Mounting brackets other than center trunnion	Center trunnion				
			ø40	ø50	ø63	ø80	ø100
D-A9□	2 (Different surfaces, Same surface), 1	15	80	—	90	105	115
	n	$15 + 40 \frac{(n-2)}{2}$ (n = 2, 4, 6, 8...) ^{Note 1)}	$80 + 40 \frac{(n-4)}{2}$ (n = 4, 8, 12, 16...) ^{Note 2)}		$90 + 40 \frac{(n-4)}{2}$ (n = 4, 8, 12, 16...) ^{Note 2)}	$105 + 40 \frac{(n-4)}{2}$ (n = 4, 8, 12, 16...) ^{Note 2)}	$115 + 40 \frac{(n-4)}{2}$ (n = 4, 8, 12, 16...) ^{Note 2)}
D-A9□V	2 (Different surfaces, Same surface), 1	10	80	—	90	105	115
	n	$10 + 30 \frac{(n-2)}{2}$ (n = 2, 4, 6, 8...) ^{Note 1)}	$80 + 30 \frac{(n-4)}{2}$ (n = 4, 8, 12, 16...) ^{Note 2)}		$90 + 30 \frac{(n-4)}{2}$ (n = 4, 8, 12, 16...) ^{Note 2)}	$105 + 30 \frac{(n-4)}{2}$ (n = 4, 8, 12, 16...) ^{Note 2)}	$115 + 30 \frac{(n-4)}{2}$ (n = 4, 8, 12, 16...) ^{Note 2)}
D-M9□ D-M9□W D-M9□A	2 (Different surfaces, Same surface), 1	15	85	100	115	120	
	n	$15 + 40 \frac{(n-2)}{2}$ (n = 2, 4, 6, 8...) ^{Note 1)}	$85 + 40 \frac{(n-4)}{2}$ (n = 4, 8, 12, 16...) ^{Note 2)}	$100 + 40 \frac{(n-4)}{2}$ (n = 4, 8, 12, 16...) ^{Note 2)}	$115 + 40 \frac{(n-4)}{2}$ (n = 4, 8, 12, 16...) ^{Note 2)}	$120 + 40 \frac{(n-4)}{2}$ (n = 4, 8, 12, 16...) ^{Note 2)}	
D-M9□V D-M9□WV D-M9□AV	2 (Different surfaces, Same surface), 1	10	85	100	115	120	
	n	$10 + 30 \frac{(n-2)}{2}$ (n = 2, 4, 6, 8...) ^{Note 1)}	$85 + 30 \frac{(n-4)}{2}$ (n = 4, 8, 12, 16...) ^{Note 2)}	$100 + 30 \frac{(n-4)}{2}$ (n = 4, 8, 12, 16...) ^{Note 2)}	$115 + 30 \frac{(n-4)}{2}$ (n = 4, 8, 12, 16...) ^{Note 2)}	$120 + 30 \frac{(n-4)}{2}$ (n = 4, 8, 12, 16...) ^{Note 2)}	
D-A5□/A6□ D-F5□/J59 D-F5□W/J59W D-F59F	2 (Different surfaces, Same surface), 1	15	90	100	110	120	
	n (Same surface)	$15 + 55 \frac{(n-2)}{2}$ (n = 2, 4, 6, 8...) ^{Note 1)}	$90 + 55 \frac{(n-4)}{2}$ (n = 4, 8, 12, 16...) ^{Note 2)}	$100 + 55 \frac{(n-4)}{2}$ (n = 4, 8, 12, 16...) ^{Note 2)}	$110 + 55 \frac{(n-4)}{2}$ (n = 4, 8, 12, 16...) ^{Note 2)}	$120 + 55 \frac{(n-4)}{2}$ (n = 4, 8, 12, 16...) ^{Note 2)}	
D-A59W	2 (Different surfaces, Same surface)	20	90	100	110	120	
	n (Same surface)	$20 + 55 \frac{(n-2)}{2}$ (n = 2, 4, 6, 8...) ^{Note 1)}	$90 + 55 \frac{(n-4)}{2}$ (n = 4, 8, 12, 16...) ^{Note 2)}	$100 + 55 \frac{(n-4)}{2}$ (n = 4, 8, 12, 16...) ^{Note 2)}	$110 + 55 \frac{(n-4)}{2}$ (n = 4, 8, 12, 16...) ^{Note 2)}	$120 + 55 \frac{(n-4)}{2}$ (n = 4, 8, 12, 16...) ^{Note 2)}	
	1	15	90	100	110	120	
D-F5NT	2 (Different surfaces, Same surface), 1	25	110	120	130	140	
	n (Same surface)	$25 + 55 \frac{(n-2)}{2}$ (n = 2, 4, 6, 8...) ^{Note 1)}	$110 + 55 \frac{(n-4)}{2}$ (n = 4, 8, 12, 16...) ^{Note 2)}	$120 + 55 \frac{(n-4)}{2}$ (n = 4, 8, 12, 16...) ^{Note 2)}	$130 + 55 \frac{(n-4)}{2}$ (n = 4, 8, 12, 16...) ^{Note 2)}	$140 + 55 \frac{(n-4)}{2}$ (n = 4, 8, 12, 16...) ^{Note 2)}	
D-B5□/B64 D-G5□/K59 D-G5□W D-K59W D-G59F D-G5NT	2	Different surfaces	15	90	100	110	
		Same surface	75				
	n	Different surfaces	$15 + 50 \frac{(n-2)}{2}$ (n = 2, 4, 6, 8...) ^{Note 1)}	$90 + 50 \frac{(n-4)}{2}$ (n = 4, 8, 12, 16...) ^{Note 2)}	$100 + 50 \frac{(n-4)}{2}$ (n = 4, 8, 12, 16...) ^{Note 2)}	$110 + 50 \frac{(n-4)}{2}$ (n = 4, 8, 12, 16...) ^{Note 2)}	
		Same surface	$75 + 50 (n-2)$ (n = 2, 4, 6, 8...)	$90 + 50 (n-2)$ (n = 2, 4, 6, 8...) ^{Note 1)}	$100 + 50 (n-2)$ (n = 2, 4, 6, 8...) ^{Note 1)}	$110 + 50 (n-2)$ (n = 2, 4, 6, 8...) ^{Note 1)}	
		1	10	90	100	110	
D-B59W	2	Different surfaces	20	90	100	110	
		Same surface	75				
	n	Different surfaces	$20 + 50 \frac{(n-2)}{2}$ (n = 2, 4, 6, 8...) ^{Note 1)}	$90 + 50 \frac{(n-4)}{2}$ (n = 4, 8, 12, 16...) ^{Note 2)}	$100 + 50 \frac{(n-4)}{2}$ (n = 4, 8, 12, 16...) ^{Note 2)}	$110 + 50 \frac{(n-4)}{2}$ (n = 4, 8, 12, 16...) ^{Note 2)}	
		Same surface	$75 + 50 (n-2)$ (n = 2, 3, 4, ...)	$90 + 50 (n-2)$ (n = 2, 4, 6, 8...) ^{Note 1)}	$100 + 50 (n-2)$ (n = 2, 4, 6, 8...) ^{Note 1)}	$110 + 50 (n-2)$ (n = 2, 4, 6, 8...) ^{Note 1)}	
		1	15	90	100	110	
D-A3□ D-G39 D-K39	2	Different surfaces	35	100	100	110	
		Same surface	100				
	n	Different surfaces	$35 + 30 (n-2)$ (n = 2, 3, 4, ...)	$100 + 30 (n-2)$ (n = 2, 4, 6, 8...) ^{Note 1)}	$100 + 30 (n-2)$ (n = 2, 4, 6, 8...) ^{Note 1)}	$110 + 30 (n-2)$ (n = 2, 4, 6, 8...) ^{Note 1)}	
		Same surface	$100 + 100 (n-2)$ (n = 2, 3, 4, ...)	$100 + 100 (n-2)$ (n = 2, 4, 6, 8...) ^{Note 1)}	$100 + 100 (n-2)$ (n = 2, 4, 6, 8...) ^{Note 1)}	$110 + 100 (n-2)$ (n = 2, 4, 6, 8...) ^{Note 1)}	
1	10	100	100	110			
D-A44	2	Different surfaces	35	90	100	110	
		Same surface	55				
	n	Different surfaces	$35 + 30 (n-2)$ (n = 2, 3, 4, ...)	$90 + 30 (n-2)$ (n = 2, 4, 6, 8...) ^{Note 1)}	$100 + 30 (n-2)$ (n = 2, 4, 6, 8...) ^{Note 1)}	$110 + 30 (n-2)$ (n = 2, 4, 6, 8...) ^{Note 1)}	
		Same surface	$55 + 50 (n-2)$ (n = 2, 3, 4, ...)	$90 + 50 (n-2)$ (n = 2, 4, 6, 8...) ^{Note 1)}	$100 + 50 (n-2)$ (n = 2, 4, 6, 8...) ^{Note 1)}	$110 + 50 (n-2)$ (n = 2, 4, 6, 8...) ^{Note 1)}	
		1	10	90	100	110	

Note 1) When "n" is an odd number, an even number that is one larger than this odd number is used for the calculation.

Note 2) When "n" is an odd number, a multiple of 4 that is larger than this odd number is used for the calculation.

Minimum Stroke For Auto Switch Mounting

n: Number of auto switches (mm)

Auto switch model	No. of auto switches mounted	Mounting brackets other than center trunnion	Center trunnion					
			ø40	ø50	ø63	ø80	ø100	
D-A3□C D-G39C D-K39C	2	Different surfaces	20		100	100	110	
		Same surface	100				110	
	n	Different surfaces	$20 + 35(n-2)$ (n = 2, 3, 4, ...)	$100 + 35(n-2)$ (n = 2, 4, 6, 8...) ^{Note 1)}		$100 + 35(n-2)$ (n = 2, 4, 6, 8...) ^{Note 1)}	$110 + 35(n-2)$ (n = 2, 4, 6, 8...) ^{Note 1)}	
		Same surface	$100 + 100(n-2)$ (n = 2, 3, 4, 5, ...)	$100 + 100(n-2)$ (n = 2, 4, 6, 8...) ^{Note 1)}			$110 + 100(n-2)$ (n = 2, 4, 6, 8...) ^{Note 1)}	
		1	10	100		100	110	
D-A44C	2	Different surfaces	20		90	100	110	
		Same surface	55				110	
	n	Different surfaces	$25 + 35(n-2)$ (n = 2, 3, 4, ...)	$90 + 35(n-2)$ (n = 2, 4, 6, 8...) ^{Note 1)}		$100 + 35(n-2)$ (n = 2, 4, 6, 8...) ^{Note 1)}	$110 + 35(n-2)$ (n = 2, 4, 6, 8...) ^{Note 1)}	
		Same surface	$55 + 50(n-2)$ (n = 2, 3, 4, ...)	$90 + 50(n-2)$ (n = 2, 4, 6, 8...) ^{Note 1)}			$110 + 50(n-2)$ (n = 2, 4, 6, 8...) ^{Note 1)}	
		1	10	90		100	110	
D-Z7□/Z80 D-Y59□/Y7P D-Y7□W	2 (Different surfaces, Same surface), 1	15	80	85	90	95	105	
	n	$15 + 40 \frac{(n-2)}{2}$ (n = 2, 4, 6, 8...) ^{Note 1)}	$80 + 40 \frac{(n-4)}{2}$ (n = 4, 8, 12, 16...) ^{Note 2)}	$85 + 40 \frac{(n-4)}{2}$ (n = 4, 8, 12, 16...) ^{Note 2)}	$90 + 40 \frac{(n-4)}{2}$ (n = 4, 8, 12, 16...) ^{Note 2)}	$95 + 40 \frac{(n-4)}{2}$ (n = 4, 8, 12, 16...) ^{Note 2)}	$105 + 40 \frac{(n-4)}{2}$ (n = 4, 8, 12, 16...) ^{Note 2)}	
D-Y69□/Y7PV D-Y7□WV	2 (Different surfaces, Same surface), 1	10	65		75	80	90	
	n	$10 + 30 \frac{(n-2)}{2}$ (n = 2, 4, 6, 8...) ^{Note 1)}	$65 + 30 \frac{(n-4)}{2}$ (n = 4, 8, 12, 16...) ^{Note 2)}		$75 + 30 \frac{(n-4)}{2}$ (n = 4, 8, 12, 16...) ^{Note 2)}	$80 + 30 \frac{(n-4)}{2}$ (n = 4, 8, 12, 16...) ^{Note 2)}	$90 + 30 \frac{(n-4)}{2}$ (n = 4, 8, 12, 16...) ^{Note 2)}	

Note 1) When "n" is an odd number, an even number that is one larger than this odd number is used for the calculation.

Note 2) When "n" is an odd number, a multiple of 4 that is larger than this odd number is used for the calculation.

Operating Range

Auto switch model	Bore size (mm)				
	40	50	63	80	100
D-A9□/A9□V	7	—	9	9	9
D-M9□/M9□V	4.5	5	5.5	5	6
D-M9□W/M9□WV					
D-M9□A/M9□AV					
D-Z7□/Z80	8	7	9	9.5	10.5
D-A3□/A44	9	10	11	11	11
D-A3□C/A44C					
D-A5□/A6□					
D-B5□/B64					
D-A59W	13	13	14	14	15
D-B59W	14	14	17	16	18
D-Y59□/Y69□	8	7	5.5	6.5	6.5
D-Y7P/Y7PV					
D-Y7□W/Y7□WV					
D-F5□/J59	4	4	4.5	4.5	4.5
D-F5□W/J59W					
D-F5NT/F59F					
D-G5□/K59	5	6	6.5	6.5	7
D-G5□W/K59W					
D-G5NT/G59F					
D-G39K39	9	9	10	10	11
D-G39C/K39C					

* D-A9□ and D-A9□V types cannot be mounted on ø50.
 * Since this is a guideline including hysteresis, not meant to be guaranteed.
 (Assuming approximately ±30% dispersion.)
 There may be the case it will vary substantially depending on an ambient environment.

Auto Switch Mounting Bracket Part No.

<Tie-rod mounting type>

Auto switch model	Bore size (mm)				
	40	50	63	80	100
D-M9□/M9□V	BA7-040	BA7-040	BA7-063	BA7-080	BA7-080
D-M9□W/M9□WV					
D-M9□A/M9□AV					
D-A9□/A9□V					
D-F5□/J59	BT-04	BT-04	BT-06	BT-08	BT-08
D-F5□W/J59W					
D-F59F/F59T					
D-A5□/A6□					
D-A59W					
D-G39C/K39C	BA3-040	BA3-050	BA3-063	BA3-080	BA3-100
D-A3□C/A44C					
D-Y59□/Y69□	BA4-040	BA4-040	BA4-063	BA4-080	BA4-080
D-Y7P/Y7PV					
D-Y7□W/Y7□WV					
D-Y7BA					
D-Z7□/Z80					

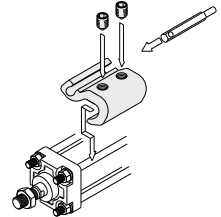

Mounting example of D-M9□(V)/M9□W(V)/M9□A(V)/A9□(V)

<Band mounting type>

Auto switch model	Bore size (mm)				
	40	50	63	80	100
D-G39/K39	BDS-04M	BDS-05M	BMB1-063	BMB1-080	BMB1-100
D-A3□/A44					
D-G5□/K59	BH2-040	BA5-050	BAF-06	BAF-08	BAF-10
D-G5□W/K59W					
D-G59F					
D-G5NT					
D-B5□/B64					
D-B59W					

Note) The auto switch mounting bracket is included in the D-A3□C/A44C/G39C/K39C types. Specify the part number as follows depending on the cylinder size when ordering.
 Ex.) ø40: D-A3□C-4, ø50: D-A3□C-5, ø63: D-A3□C-6
 ø80: D-A3□C-8, ø100: D-A3□C-10

Other than the models listed in "How to Order", the following auto switches are applicable.

For detailed specifications, refer to pages 1341 to 1435.

Auto switch type	Model	Electrical entry (Fetching direction)	Features
Reed	D-A93V, A96V	Grommet (Perpendicular)	—
	D-A90V		Without indicator light
	D-A53, A56, B53, Z73, Z76	Grommet (In-line)	—
	D-A67, Z80		Without indicator light
Solid state	D-M9NV, M9PV, M9BV	Grommet (Perpendicular)	—
	D-Y69A, Y69B, Y7PV		Diagnostic indication (2-color indicator)
	D-M9NWV, M9PWV, M9BWW		Water resistant (2-color indicator)
	D-Y7NWV, Y7PWV, Y7BWW		—
	D-M9NAV, M9PAV, M9BAV		—
	D-Y59A, Y59B, Y7P	Grommet (In-line)	—
	D-F59, F5P, J59		Diagnostic indication (2-color indicator)
	D-Y7NW, Y7PW, Y7BW		With timer
	D-F59W, F5PW, J59W		—
	D-F5NT, G5NT		—

* With pre-wired connector is also available in solid state auto switches.

For details, refer to pages 1410 and 1411.

* Normally closed (NC = b contact), solid state auto switches (D-M9□(V)/Y7G/Y7H type) are also available. For details, refer to pages 1360 and 1362.

Valve Mounted Cylinder Double Acting CVS1 Series

ø40, ø50, ø63, ø80, ø100

How to Order

Mounting type

B	Basic type
L	Axial foot type
F	Rod side flange type
G	Head side flange type
C	Single clevis type
D	Double clevis type
T	Center trunnion type

Cylinder stroke (mm)

Refer to page 1239 for standard strokes.

Bore size

40	40 mm
50	50 mm
63	63 mm
80	80 mm
100	100 mm

Electrical entry

Nil	Grommet
T	Conduit terminal
D	DIN terminal
DL	DIN terminal with indicator light
TZ	Conduit terminal with surge voltage suppressor

Made to Order

Refer to page 1239 for details.

Solenoid valve

Nil	2 position single (VS4124-00□□-X46)
W	2 position double (VS4224-00□□)
Y	3 position closed center (VS4324-00□□)
Z	3 position exhaust center (VS4424-00□□)

Number of auto switches

Nil	2 pcs.	S	1 pc.
3	3 pcs.	n	"n" pcs.

Suffix for cylinder

Rod boot	J	Nylon tarpaulin
	K	Heat resistant tarpaulin
	N	Rubber bumper
Cushion	R	With cushion on rod end
	H	With cushion on head end
	Nil	With cushion on both ends

* When specifying symbol more than one, combine symbols alphabetically.

Auto switch

Nil	Without auto switch
-----	---------------------

* For the applicable auto switch model, refer to the table below.

Solenoid valve voltage

Refer to page 1239 for the solenoid valve voltage.

With auto switch

With Auto Switch
(Built-in magnet)

Built-in Magnet Cylinder Model

Nil	Aluminum tube
F*	Steel tube

* Not available with auto switch.

Type

Nil	Aluminum tube
F*	Steel tube

Example Order Codes:

CVS1 L N 40 - 100 - 1 W D

CDVS1 L N 40 - 100 - M9BW - 1 W D

Applicable Auto Switches

Refer to pages 1341 to 1435 for further information on auto switches.

Type	Special function	Electrical entry	Wiring (Output)	Load voltage		Auto switch model		Lead wire length (m)					Pre-wired connector	Applicable load	
				DC	AC	Tie-rod mounting	Band mounting	0.5 (Nil)	1 (M)	3 (L)	5 (Z)				
Solid state auto switch	—	Grommet	3-wire (NPN)	24 V	5 V, 12 V	—	M9N	●	●	●	○	○	IC circuit	Relay, PLC	
			3-wire (PNP)				G59**	●	—	●	○	○			
			2-wire				M9B	●	●	●	○	○			
		Terminal conduit	3-wire (NPN)		12 V	G39C	G39	—	—	—	—				
			2-wire			K39C	K39	—	—	—	—				
			3-wire (NPN)			M9NW	—	●	●	●	○	○			
	Diagnostic indication (2-color indicator)	Grommet	3-wire (PNP)	24 V	5 V, 12 V	—	M9PW	●	●	●	○	○	IC circuit		
			3-wire (PNP)				G59W**	●	—	●	○	○			
			2-wire				M9B	●	●	●	○	○			
		Grommet	3-wire (NPN)		12 V	M9BW	—	●	●	●	○	○	—		
			3-wire (PNP)			K59W**	●	—	●	○	○				
			2-wire			M9NA* ¹	—	○	○	●	○	○			
Water resistant (2-color indicator)	Grommet	3-wire (PNP)	24 V	5 V, 12 V	—	M9PA* ¹	—	○	○	●	○	○	IC circuit		
		2-wire				M9BA* ¹	—	○	○	●	○	○			
		4-wire (NPN)				F59F	G59F**	●	—	●	○	○			
Reed auto switch	—	Grommet	3-wire (NPN equivalent)	24 V	12 V	—	A96	●	●	●	●	○	IC circuit	Relay, PLC	
			2-wire				A93	—	●	●	●	●			○
			2-wire				A90	—	●	●	●	●			○
		Terminal conduit	2-wire		12 V	A54	B54**	●	—	●	—	—			
			2-wire			A64	B64**	●	—	●	—	—			
			2-wire			A33C	A33	—	—	—	—	—			
	Diagnostic indication (2-color indicator)	Grommet	2-wire	12 V	100 V, 200 V	—	A34C	A34	—	—	—	—	—		—
			2-wire				A44C	A44	—	—	—	—	—		
			2-wire				A59W	B59W**	●	—	●	—	—		

*1 Water resistant type auto switches can be mounted on the above models, but in such case SMC cannot guarantee water resistance.

*2 The load voltage used is 24 VDC.

* Lead wire length symbols: 0.5 m Nil (Example) M9NW
1 m M (Example) M9NMW
3 m L (Example) M9NLW
5 m Z (Example) M9NZW

* Auto switches marked with "○" are produced upon receipt of order.

** D-B5□/G5□/K5□ types are mountable only upon a receipt of order. (Not mountable after the time of shipment)

* Since there are other applicable auto switches than listed, refer to page 1251 for details.

* For details about auto switches with pre-wired connector, refer to pages 1410 and 1411.

* D-A9□/M9□/M9□W/M9□A auto switches are shipped together (not assembled). (Only auto switch mounting brackets are assembled before shipped.)

Speed controller installed

Operation type can be changed to rod extended when energized or rod retracted when energized.

A selection of solenoid valves is possible.

Single, double and 3 position solenoid valves are mountable.

An auto switch cylinder with the switch installed can also be manufactured.



Symbol

Air cushion

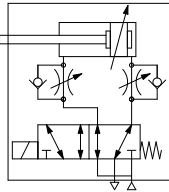

Made to Order Specifications

[Click here for details](#)

Symbol	Specifications
-XA□	Change of rod end shape
-XC4	With heavy duty scraper
-XC6	Made of stainless steel
-XC14	Change of trunnion bracket mounting position
-XC15	Change of tie-rod length

Refer to pages 1246 to 1251 for cylinders with auto switches.

- Proper auto switch mounting position (detection at stroke end) and mounting height
- Minimum auto switch mounting stroke
- Operating range
- Auto switch mounting bracket: Part no.

Specifications

Bore size (mm)		40	50	63	80	100	
Fluid	Air						
Action	Double acting						
Proof pressure	1.5 MPa						
Maximum operating pressure	1.0 MPa						
Ambient and fluid temperatures	-10 to 60°C *1						
Minimum operating pressure	0.05 MPa						
Piston speed	50 to 500 mm/s *3						
Cushion	Air cushion or Rubber bumper						
Stroke length tolerance	Up to 250 ^{+0.10} , 251 to 1000 ^{+0.14}						
Lubrication	Not required (Non-lube)						
Mounting	Basic type, Foot type, Rod side flange type, Head side flange type, Single clevis type, Double clevis type, Center trunnion type						
Port size	Rc 1/4						
Allowable kinetic energy (J) *2	Air cushion	When activated	2.8	4.6	7.8	16	29
		When not activated	0.33	0.56	0.91	1.5	2.68
	Rubber bumper	1.8	3.6	6.0	12.0	12.0	

*1 No freezing

*2 Activate the air cushion when operating the cylinder. If this is not done, the piston rod assembly or the tie-rods will be damaged when the allowable kinetic energy exceeds the values shown in the above table.

*3 For operating piston speed for each size, refer to page 1240.

Solenoid Valve Specifications

Applicable solenoid valve model		VS4□24		
Coil rated voltage		Refer to the solenoid valve voltage shown below.		
Electrical entry		Grommet, Conduit terminal, DIN terminal, DIN terminal with indicator light, Conduit terminal with surge voltage suppressor		
Allowable voltage		-15 to 10% of the rated voltage		
Coil insulation		Class B or equivalent (130°C)		
Apparent power ^(Note)	AC	Inrush	50 Hz	100 VA
			60 Hz	90 VA
		Holding	50 Hz	20 VA
			60 Hz	14 VA
Power consumption ^(Note)	DC	13.2 W		

Note) At the rated voltage.

Solenoid valve voltage

1	100 VAC (50/60 Hz)
2	200 VAC (50/60 Hz)
3	110 VAC (50/60 Hz)
4	220 VAC (50/60 Hz)
5	24 VDC
6	12 VDC
B	24 VAC (50/60 Hz)
P	100 VDC
W	32 VDC
Y	48 VDC
Z	110 VDC

For other rated voltages, please contact SMC.

Standard Strokes

Bore size	Standard stroke (mm)	
	Stroke range ①	Stroke range ②
40	25, 50, 75, 100, 125, 150, 200, 250, 300, 350, 400, 450, 500	Up to 1000
50, 63	25, 50, 75, 100, 125, 150, 200, 250, 300, 350, 400, 450, 500, 600	
80, 100	25, 50, 75, 100, 125, 150, 200, 250, 300, 350, 400, 450, 500, 600, 700	

Note 1) Intermediate strokes not listed above are produced upon receipt of order.

Note 2) Applicable strokes should be confirmed according to the usage. For details, refer to "Air Cylinders Model Selection" in the **Web Catalog**. In addition, the products that exceed the stroke range ① might not be able to fulfill the specifications due to the deflection etc.

Note 3) Please consult with SMC for manufacturability and the part numbers when exceeding the stroke range ②.

Note 4) The minimum stroke length is different in the trunnion type and types with auto switch. Refer to pages 1248 and 1249.

Rod Boot Material

Symbol	Rod boot material	Max. ambient temperature
J	Nylon tarpaulin	70°C
K	Heat resistant tarpaulin	110°C *

* Maximum ambient temperature for the rod boot itself.

CVS1 Series

Accessory

Mounting		Basic type	Axial foot type	Rod side flange type	Head side flange type	Single clevis type	Double* clevis type	Center trunnion type
Standard equipment	Rod end nut	●	●	●	●	●	●	●
	Clevis pin	—	—	—	—	—	●	—
Option	Single knuckle joint	●	●	●	●	●	●	●
	Double knuckle joint* (with pin)	●	●	●	●	●	●	●
	With rod boot	●	●	●	●	●	●	●

* Pin, plain washer and cotter pin are packaged together with double clevis and double knuckle joint.

* Refer to page 1245 for dimensions and part numbers of the option.
Refer to page 1242 for dimensions of the rod boot.

Weight

(kg)

Bore size (mm)		40	50	63	80	100
Basic weight	Basic type	2.32(2.42)	2.73(2.86)	3.67(3.88)	5.25(5.56)	6.81(7.21)
	Axial foot type	2.49(2.59)	2.93(3.06)	3.96(4.17)	6.04(6.35)	7.74(8.14)
	Rod side flange type	2.72(2.82)	3.33(3.46)	4.63(4.84)	7.09(7.40)	9.13(9.53)
	Head side flange type	2.82(2.92)	3.47(3.60)	4.63(4.84)	7.09(7.40)	9.13(9.53)
	Single clevis type	2.58(2.68)	3.17(3.30)	4.42(4.63)	6.63(6.94)	9.11(9.51)
	Double clevis type	2.57(2.67)	3.15(3.28)	4.44(4.65)	6.62(6.93)	9.13(9.53)
	Trunnion type	2.92(3.07)	3.47(3.66)	5.01(5.38)	7.58(8.03)	10.33(10.92)
Additional weight per each 50 mm of stroke		0.20(0.28)	0.25(0.35)	0.31(0.43)	0.46(0.70)	0.58(0.87)
Accessory bracket	Single knuckle	0.23	0.26	0.26	0.60	0.83
	Double knuckle (with pin)	0.37	0.43	0.43	0.87	1.27

Calculation: (Example) **CVS1L40-100-1**

- Basic weight.....2.48 (kg)
- Additional weight.....0.20 (kg/50 st)
- Cylinder stroke.....100 (st) $2.48 + 0.20 \times 100 + 50 = 2.88$ kg

* (): Steel tube type

Mounting Bracket Part No.

Bore size (mm)	40	50	63	80	100
Axial foot*	CA1-L04	CA1-L05	CA1-L06	CA1-L08	CA1-L10
Flange	CA1-F04	CA1-F05	CA1-F06	CA1-F08	CA1-F10
Single clevis	CA1-C04	CA1-C05	CA1-C06	CA1-C08	CA1-C10
Double clevis**	CA1-D04	CA1-D05	CA1-D06	CA1-D08	CA1-D10

* Order two foot brackets per cylinder.

** Accessories for each mounting bracket are as follows.

Foot, Flange, Single clevis: Body mounting bolts, Spring washer
Double clevis: Body mounting bolts, Spring washer, Clevis pin, Flat washer, Cotter pin.

Opening Range of Throttle Valve and Piston Speed

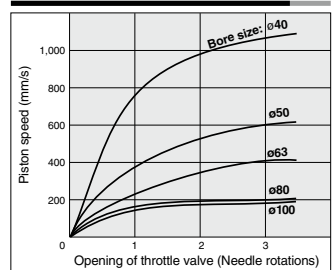

Conditions: Operating pressure 0.5 MPa,
Horizontal mounting, No load, Extending stroke
• The speed shown above are for reference.

Piston Speed Adjustment Procedure

- To slow down the piston speed, screw in the speed controller needle clockwise, which reduces the amount of air that is discharged.
- The speed controller needle opens fully when it is loosened 3 1/2 turns from its fully closed position. After the specified speed has been set, secure the needle with the lock nut.

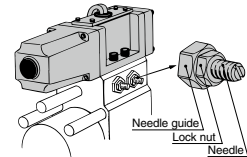

Changing between Rod Extended when Energized and Rod Retracted when Energized

- This is possible by reversing the SUP port and EXH port piping.

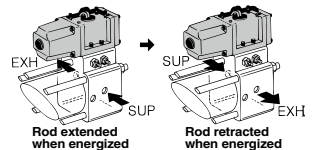

- This is possible by inverting the solenoid valve direction 180°.

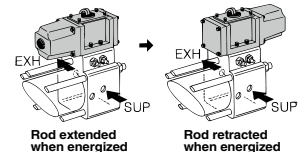

Manual Operation

Using a screwdriver or its equivalent, push the center of the rubber plug on the head of the solenoid cap of the solenoid valve.

(It is not necessary to remove the rubber plug.)

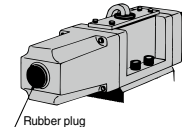

Construction

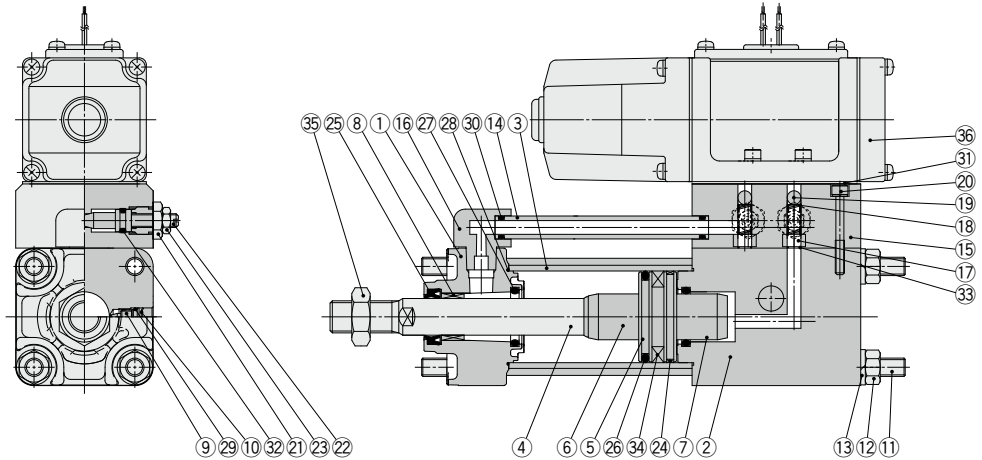

Component Parts

No.	Description	Material	Qty	Note
1	Rod cover	Aluminum die-casted	1	Black painted
2	Head cover	Aluminum alloy	1	Black painted
3	Cylinder tube	Aluminum alloy	1	Hard anodized
4	Piston rod	Carbon steel	1	Hard chrome plating
5	Piston	Aluminum alloy	1	
6	Cushion ring A	Aluminum alloy	1	Anodized
7	Cushion ring B	Aluminum alloy	1	Anodized
8*	Bushing	Bearing alloy	1	
9	Cushion valve	Steel wire	2	Trivalent zinc chromated
10	Retaining ring	Spring steel	2	Phosphate coating
11	Tie-rod	Carbon steel	4	Trivalent zinc chromated
12	Tie-rod nut	Rolled steel	8	Trivalent black zinc chromated
13	Spring washer	Steel wire	8	Trivalent black zinc chromated
14	Pipe	Carbon steel tube	1	Trivalent zinc chromated
15	Sub-plate	Aluminum die-casted	1	Platinum silver
16*	Guide tube fitting	Aluminum die-casted	1	Platinum silver
17*	Valve port	Rolled steel	2	Electroless nickel plating
18*	Check spring	Spring steel	2	Trivalent zinc chromated

No.	Description	Material	Qty	Note
19*	Check ball	Polyurethane rubber	2	Ball 9/32
20	Hex. socket head cap screw with SW	Chromium molybdenum steel	4	Trivalent zinc chromated
21	Needle guide	Carbon steel	2	Trivalent zinc chromated
22	Speed adjustment needle	Rolled steel	2	Electroless nickel plating
23	Lock nut	Carbon steel	2	Trivalent zinc chromated
24	Wear ring	Resin	1	
25	Rod seal	NBR	1	
26	Piston seal	NBR	1	
27*	Cushion seal	Urethane	2	
28	Cylinder tube gasket	NBR	2	
29*	Cushion valve seal	NBR	2	
30	Pipe gasket	NBR	2	
31	Gasket	NBR	1	
32	Speed adjustment needle seal	NBR	2	
33	Valve port gasket	NBR	4	
34	Magnet	—	(1)	
35	Rod end nut	Rolled steel	1	Trivalent zinc chromated
36	Solenoid valve	—	1	VS4124-00□-X46

Note) Add “-X46” to the end of the part numbers for single solenoid type.

* How to order solenoid valves/VS4□24-00 [Voltage] [Electrical entry]

* Not replaceable.

Replacement Parts: Seal Kit

Bore size (mm)	Kit no.	Contents
40	CVS1N40-PS	Set of nos. above 25, 26, 28, 30, 33
50	CVS1N50-PS	
63	CVS1N63-PS	
80	CVS1N80-PS	
100	CVS1N100-PS	

* Seal kit includes 25, 26, 28, 30, and 33. Order the seal kit based on each bore size. (The parts indicated with numbers 27 and 29 are not replaceable.)

* Seal kit includes a grease pack (ø40, ø50: 10 g, ø63, ø80: 20 g, ø100: 30 g).

Order with the following part number when only the grease pack is needed.

Grease pack part no.: GR-S-010 (10 g), GR-S-020 (20 g)

CVS1 Series

Basic Type: CVS1B

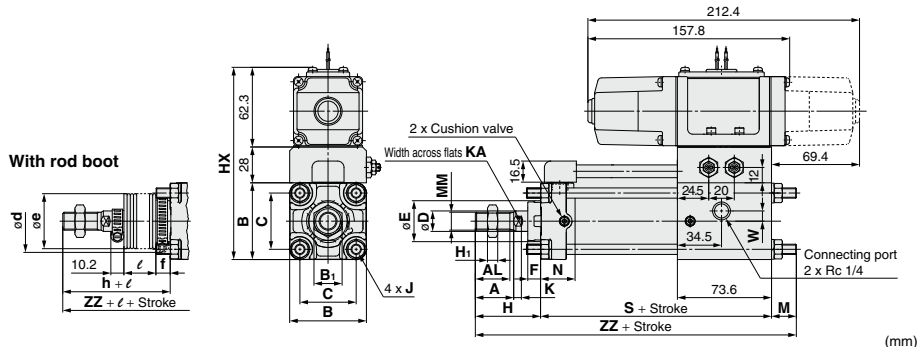

Bore size (mm)	Stroke* range (mm)	A	AL	B	B ₁	C	D	E	F	H ₁	HX	J	K	KA	M	MM	N	S
40	Up to 1000	30	27	60	22	44	16	32	10	8	150	M8 x 1.25	6	14	19.4	M14 x 1.5	27	130.6
50	Up to 1000	35	32	70	27	52	20	40	10	11	160	M8 x 1.25	7	18	16.4	M18 x 1.5	30	133.6
63	Up to 1000	35	32	85	27	64	20	40	10	11	175	M10 x 1.25	7	18	18.4	M18 x 1.5	31	140.6
80	Up to 1000	40	37	102	32	78	25	52	14	13	192	M12 x 1.75	10	22	21.4	M22 x 1.5	37	152.6
100	Up to 1000	40	37	116	41	92	30	52	14	16	206	M12 x 1.75	10	26	21.4	M26 x 1.5	40	159.6

Bore size (mm)	W	Without rod boot		With rod boot						ZZ	* The minimum stroke of the one with rod boot is 20 mm or more.
		H	ZZ	d	e	f	h	ℓ			
40	8	51	201	56	43	11.2	59	1/4 stroke	209		
50	8	58	208	64	52	11.2	66	1/4 stroke	216		
63	8	58	217	64	52	11.2	66	1/4 stroke	225		
80	0	71	245	76	65	12.5	80	1/4 stroke	254		
100	0	72	253	76	65	14	81	1/4 stroke	262		

Axial Foot Type: CVS1L

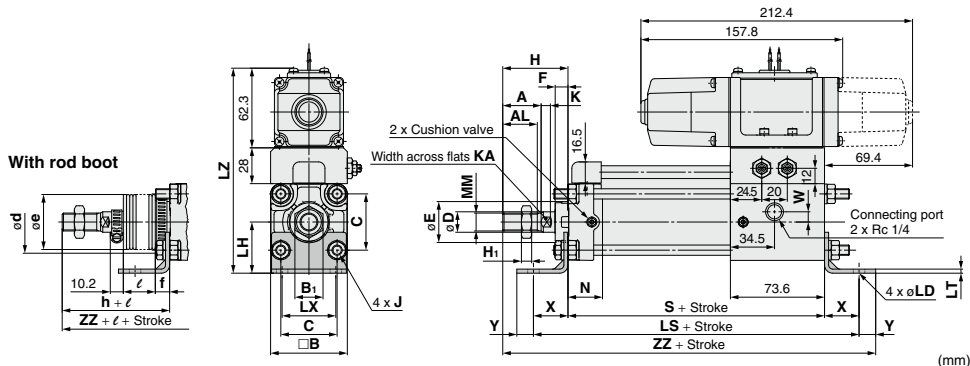

Bore size (mm)	Stroke* range (mm)	A	AL	B	B ₁	C	D	E	F	H ₁	J	K	KA	LD	LH	LS	LT	LX	LZ	MM
40	Up to 1000	30	27	60	22	44	16	32	10	8	M8 x 1.25	6	14	9	40	184.6	3.2	42	160	M14 x 1.5
50	Up to 1000	35	32	70	27	52	20	40	10	11	M8 x 1.25	7	18	9	45	187.6	3.2	50	170	M18 x 1.5
63	Up to 1000	35	32	85	27	64	20	40	10	11	M10 x 1.25	7	18	11.5	50	208.6	3.2	59	182	M18 x 1.5
80	Up to 1000	40	37	102	32	78	25	52	14	13	M12 x 1.75	10	22	13.5	65	240.6	4.5	76	206	M22 x 1.5
100	Up to 1000	40	37	116	41	92	30	52	14	16	M12 x 1.75	10	26	13.5	75	245.6	6	92	223	M26 x 1.5

Bore size (mm)	N	S	W	X	Y	Without rod boot		With rod boot						ZZ	* The minimum stroke of the one with rod boot is 20 mm or more.
						H	ZZ	d	e	f	h	ℓ			
40	27	130.6	8	27	13	51	221.6	56	43	11.2	59	1/4 stroke	229.6		
50	30	133.6	8	27	13	58	231.6	64	52	11.2	66	1/4 stroke	239.6		
63	31	140.6	8	34	16	58	248.6	64	52	11.2	66	1/4 stroke	256.6		
80	37	152.6	0	44	16	71	283.6	76	65	12.5	80	1/4 stroke	292.6		
100	40	159.6	0	43	17	72	291.6	76	65	14	81	1/4 stroke	300.6		

Rod Side Flange Type: CVS1F

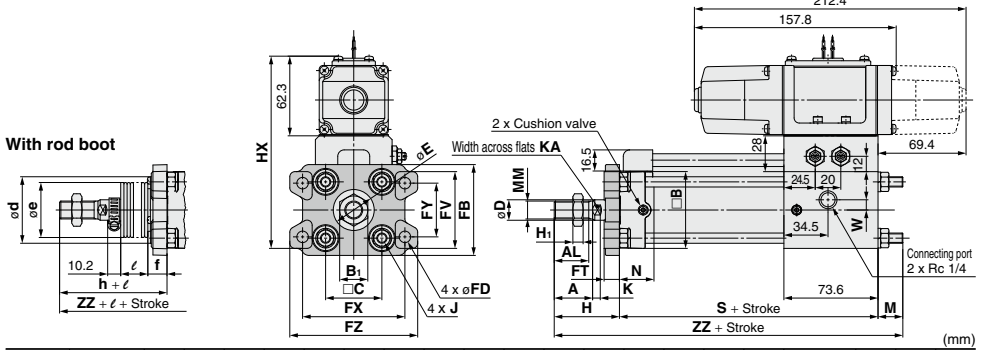

Bore size (mm)	Stroke* range (mm)	A	AL	B	B ₁	C	D	E	FB	FD	FT	FV	FX	FY	FZ	H ₁	HX	J	K	KA	M
40	Up to 1000	30	27	60	22	44	16	32	71	9	12	60	80	42	100	8	150	M8 x 1.25	6	14	19.4
50	Up to 1000	35	32	70	27	52	20	40	81	9	12	70	90	50	110	11	160	M8 x 1.25	7	18	16.4
63	Up to 1000	35	32	85	27	64	20	40	101	11.5	15	86	105	59	130	11	175	M10 x 1.25	7	18	18.4
80	Up to 1000	40	37	102	32	78	25	52	119	13.5	18	102	130	76	160	13	192	M12 x 1.75	10	22	21.4
100	Up to 1000	40	37	116	41	92	30	52	133	13.5	18	116	150	92	180	16	206	M12 x 1.75	10	26	21.4

Bore size (mm)	MM	N	S	W	Without rod boot		With rod boot						
					H	ZZ	d**	e	f	h	l	ZZ	
40	M14 x 1.5	27	130.6	8	51	201	52	43	15	59	1/4 stroke	209	
50	M18 x 1.5	30	133.6	8	58	208	58	52	15	66	1/4 stroke	216	
63	M18 x 1.5	31	140.6	8	58	217	58	52	17.5	66	1/4 stroke	225	
80	M22 x 1.5	37	152.6	0	71	245	80	65	21.5	80	1/4 stroke	254	
100	M26 x 1.5	40	159.6	0	72	253	80	65	21.5	81	1/4 stroke	262	

* The minimum stroke of the one with rod boot is 20 mm or more.
 ** Long stroke
 *** Machine larger holes than the outside diameter ϕd of the mounting bracket for rod boot when mounting the rod boot part to the through for mounting.

Head Side Flange Type: CVS1G

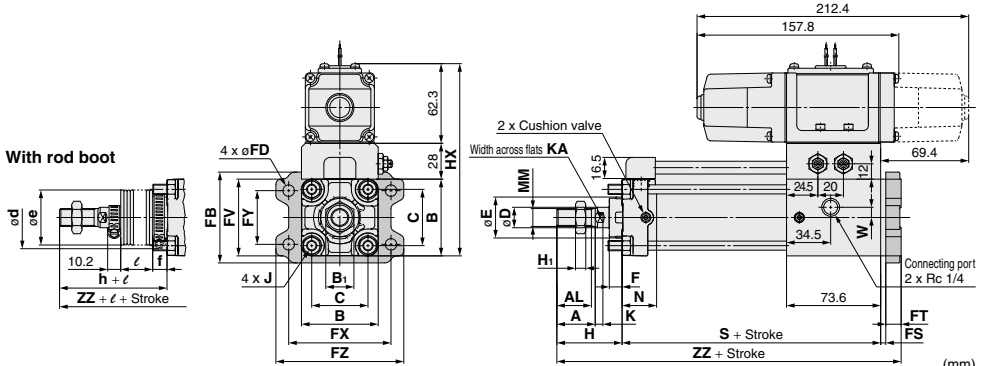

Bore size (mm)	Stroke* range (mm)	A	AL	B	B ₁	C	D	E	F	FB	FD	FT	FV	FX	FY	FZ	H ₁	HX	J	K
40	Up to 1000	30	27	60	22	44	16	32	10	71	9	12	60	80	42	100	8	150	M8 x 1.25	6
50	Up to 1000	35	32	70	27	52	20	40	10	81	9	12	70	90	50	110	11	160	M8 x 1.25	7
63	Up to 1000	35	32	85	27	64	20	40	10	101	11.5	15	86	105	59	130	11	175	M10 x 1.25	7
80	Up to 1000	40	37	102	32	78	25	52	14	119	13.5	18	102	130	76	160	13	192	M12 x 1.75	10
100	Up to 1000	40	37	116	41	92	30	52	14	133	13.5	18	116	150	92	180	16	206	M12 x 1.75	10

Bore size (mm)	KA	MM	N	S	W	Without rod boot		With rod boot						
						H	ZZ	d	e	f	h	l	ZZ	
40	14	M14 x 1.5	27	130.6	8	51	197.6	56	43	11.2	59	1/4 stroke	205.6	
50	18	M18 x 1.5	30	133.6	8	58	207.6	64	52	11.2	66	1/4 stroke	215.6	
63	18	M18 x 1.5	31	140.6	8	58	213.6	64	52	11.2	66	1/4 stroke	221.6	
80	22	M22 x 1.5	37	152.6	0	71	241.6	76	65	12.5	80	1/4 stroke	250.6	
100	26	M26 x 1.5	40	159.6	0	72	249.6	76	65	14	81	1/4 stroke	258.6	

* The minimum stroke of the one with rod boot is 20 mm or more.

CVS1 Series

Single Clevis Type: CVS1C

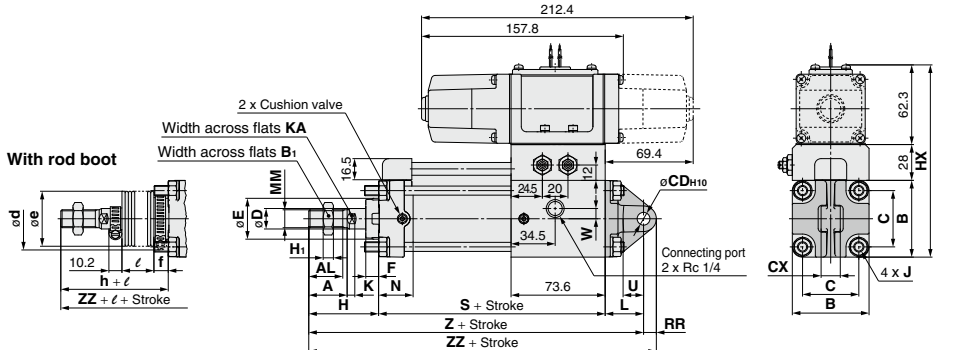

Bore size (mm)	Stroke* range (mm)	A	AL	B	B ₁	C	CD _{H10}	CX	D	E	F	H ₁	HX	J	K	KA	L	MM
40	Up to 1000	30	27	60	22	44	10 ^{+0.058} _{-0.03}	15 ^{-0.1} _{-0.3}	16	32	10	8	150	M8 x 1.25	6	14	30	M14 x 1.5
50	Up to 1000	35	32	70	27	52	12 ^{+0.070} _{-0.04}	18 ^{-0.1} _{-0.3}	20	40	10	11	160	M8 x 1.25	7	18	35	M18 x 1.5
63	Up to 1000	35	32	85	27	64	16 ^{+0.070} _{-0.04}	25 ^{-0.1} _{-0.3}	20	40	10	11	175	M10 x 1.25	7	18	40	M18 x 1.5
80	Up to 1000	40	37	102	32	78	20 ^{+0.084} _{-0.05}	31.5 ^{-0.1} _{-0.3}	25	52	14	13	192	M12 x 1.75	10	22	48	M22 x 1.5
100	Up to 1000	40	37	116	41	92	25 ^{+0.084} _{-0.05}	35.5 ^{-0.1} _{-0.3}	30	52	14	16	206	M12 x 1.75	10	26	58	M26 x 1.5

Bore size (mm)	N	RR	S	U	W	Without rod boot			With rod boot						
						H	Z	ZZ	d	e	f	h	ℓ	Z	ZZ
40	27	10	130.6	16	8	51	211.6	221.6	56	43	11.2	59	1/4 stroke	219.6	229.6
50	30	12	133.6	19	8	58	266.6	238.6	64	52	11.2	66	1/4 stroke	234.6	246.6
63	31	16	140.6	23	8	58	238.6	254.6	64	52	11.2	66	1/4 stroke	246.6	262.6
80	37	20	152.6	28	0	71	271.6	291.6	76	65	12.5	80	1/4 stroke	280.6	300.6
100	40	25	159.6	36	0	72	289.6	314.6	76	65	14	81	1/4 stroke	298.6	323.6

* The minimum stroke of the one with rod boot is 20 mm or more.

Double Clevis Type: CVS1D

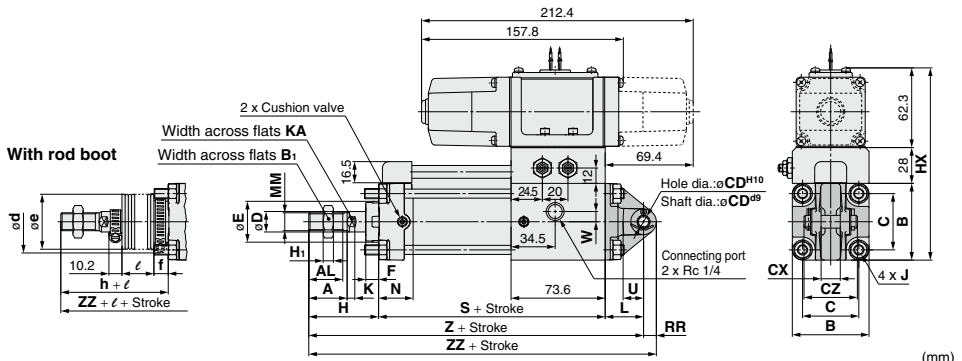

Bore size (mm)	Stroke* range (mm)	A	AL	B	B ₁	C	CD _{H10}	CX	CZ	D	E	F	H ₁	HX	J	K	KA	L
40	Up to 1000	30	27	60	22	44	10 ^{+0.058} _{-0.03}	15 ^{+0.3} _{-0.1}	29.5	16	32	10	8	150	M8 x 1.25	6	14	30
50	Up to 1000	35	32	70	27	52	12 ^{+0.070} _{-0.04}	18 ^{+0.3} _{-0.1}	38	20	40	10	11	160	M8 x 1.25	7	18	35
63	Up to 1000	35	32	85	27	64	16 ^{+0.070} _{-0.04}	25 ^{+0.3} _{-0.1}	49	20	40	10	11	175	M10 x 1.25	7	18	40
80	Up to 1000	40	37	102	32	78	20 ^{+0.084} _{-0.05}	31.5 ^{+0.3} _{-0.1}	61	25	52	14	13	192	M12 x 1.75	10	22	48
100	Up to 1000	40	37	116	41	92	25 ^{+0.084} _{-0.05}	35.5 ^{+0.3} _{-0.1}	64	30	52	14	16	206	M12 x 1.75	10	26	58

Bore size (mm)	MM	N	RR	S	U	W	Without rod boot			With rod boot						
							H	Z	ZZ	d	e	f	h	ℓ	Z	ZZ
40	M14 x 1.5	27	10	130.6	16	8	51	211.6	221.6	56	43	11.2	59	1/4 stroke	219.6	229.6
50	M18 x 1.5	30	12	133.6	19	8	58	266.6	238.6	64	52	11.2	66	1/4 stroke	234.6	246.6
63	M18 x 1.5	31	16	140.6	23	8	58	238.6	254.6	64	52	11.2	66	1/4 stroke	246.6	262.6
80	M22 x 1.5	37	20	152.6	28	0	71	271.6	291.6	76	65	12.5	80	1/4 stroke	280.6	300.6
100	M26 x 1.5	40	25	159.6	36	0	72	289.6	314.6	76	65	14	81	1/4 stroke	298.6	323.6

* The minimum stroke of the one with rod boot is 20 mm or more.

* Clevis pin, flat washer and cotter pin are shipped together.

Auto Switch Mounting

Auto Switch Proper Mounting Position (Detection at Stroke End) and Mounting Height

<Tie-rod mounting type>

- D-M9□/M9□V D-Z7□/Z80
- D-M9□W/M9□WV D-Y59□/Y69□/Y7P/Y7PV
- D-M9□A/M9□AV D-Y7□W/Y7□WV
- D-A9□/A9□V

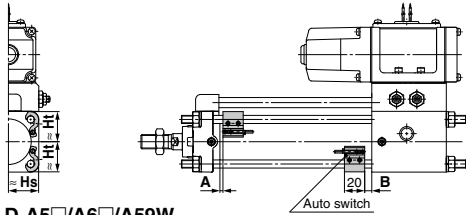

D-A5□/A6□/A59W

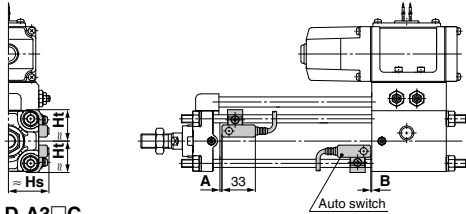

D-A3□C
D-G39C/K39C

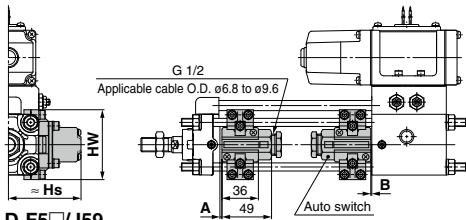

D-F5□/J59

D-F5NT
D-F5□W/J59W/F59F

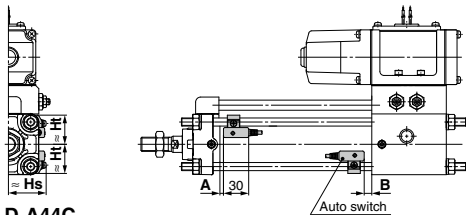

D-A44C

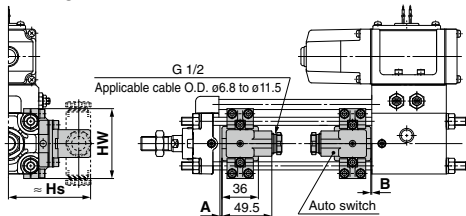

<Band mounting type>

- D-B5□/B64/B59W

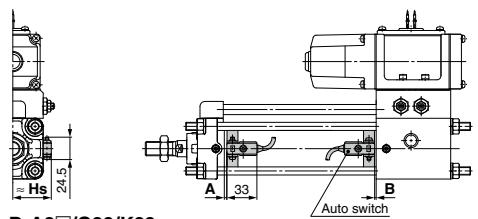

D-A3□/G39/K39

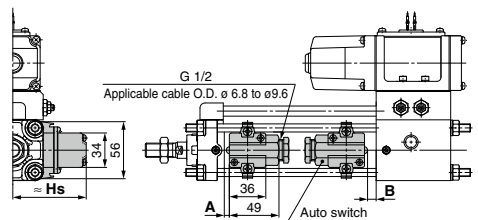

D-G5□/K59/G5□W/K59W
D-G59F/G5NT

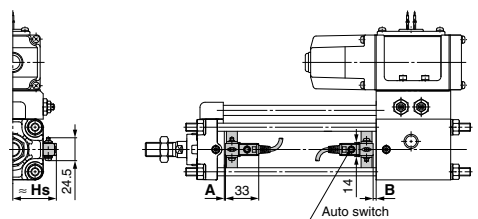

D-A44

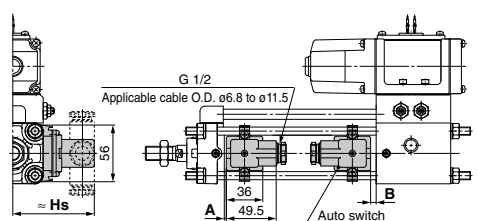

Auto Switch Proper Mounting position (Detection at Stroke End) and Mounting Height

Auto Switch Proper Mounting Position (Standard type)

(mm)

Auto switch model	D-M9□ D-M9□V D-M9□W D-M9□WV D-M9□A D-M9□AV		D-A9□ D-A9□V		D-Y59□ D-Y69□ D-Y7P D-Y7PV D-Y7□W D-Y7BA D-Z7□ D-Z80 D-B59W		D-F5□ D-J59 D-F59F D-F5□W D-J59W D-F5BA		D-F5NT		D-A59W		D-G39 D-G39C D-K39 D-K39C D-A5□ D-A6□ D-A3□ D-A3□C D-A44 D-A44C		D-G5□ D-K59 D-G5NT D-G5□W D-K59W D-G5BA D-G59F		D-B5□ D-B64			
	A	B	A	B	A	B	A	B	A	B	A	B	A	B	A	B	A	B	A	B
40	9	9	5	5	2.5	2.5	5.5	5.5	10.5	10.5	3	3	0	0	1	1	0	0		
50	9.5	8.5	5.5	4.5	3	2	6	5	11	10	3.5	2.5	0	0	1.5	0.5	0	0		
63	12.5	11.5	8.5	7.5	6	5	9	8	14	13	6.5	5.5	2.5	1.5	4.5	3.5	3	2		
80	16.5	13.5	12.5	9.5	10	7	13	10	18	15	10.5	7.5	6.5	3.5	8.5	5.5	7	4		
100	18	16	14	12	11.5	9.5	14.5	12.5	19.5	17.5	12	10	8	6	10	8	8.5	6.5		

Note 1) D-B5□ type, D-G5□ type, D-K5□ type are mountable only upon a receipt of order. (Not mountable after the time of shipment)

Note 2) Adjust the auto switch after confirming the operating conditions in the actual setting.

Auto Switch Mounting Height (Standard type)

(mm)

Auto switch model	D-M9□ D-M9□W D-M9□A D-A9□		D-M9□V D-M9□WV D-M9□AV		D-A9□V		D-Y59□ D-Y7P D-Y7BA D-Y7□W D-Z7□ D-Z80		D-Y69□ D-Y7PV D-Y7□WV		D-G5□ D-K59 D-G5NT D-G5□W D-K59W D-G5BA D-G59F D-B5□ D-B64 D-B59W		D-G39 D-K39 D-A3□		D-A44		D-F5□ D-J59 D-F5□W D-J59W D-F5BA D-F59F D-F5NT		D-A6□ D-A59W		D-G39C D-K39C D-A3□C		D-A44C	
	Hs	Ht	Hs	Ht	Hs	Ht	Hs	Ht	Hs	Ht	Hs	Ht	Hs	Ht	Hs	Ht	Hs	Ht	Hs	Ht	Hs	Ht	Hs	Ht
40	30	30	34	30	31	30	30	30	30	30	37	71.5	81.5	38	31.5	38.5	31.5	73	69	81	69			
50	34	34	38	34	35	34	34	34	34	34	42	76.5	86.5	42	35.5	42	35.5	78.5	77	86.5	77			
63	41	41	44	41	41.5	41	41	41	41	41	49	83.5	93.5	47	43	46.5	43	85.5	91	93.5	91			
80	49.5	49	52.5	49	50	49	49.5	49	49.5	49	57.5	92	102	53.5	51	53.5	51	94	107	102	107			
100	56.5	56	61	56	58.5	56	56.5	55.5	57.5	55.5	68	102.5	112.5	61	57.5	61.5	57.5	104	121	112	121			

Minimum Stroke for Auto Switch Mounting (Standard Type)

		n: Number of auto switches (mm)					
Auto switch model	Number of auto switches	Brackets other than center trunnion	Center trunnion				
			ø40	ø50	ø63	ø80	ø100
D-M9□ D-M9□W	2 (Different surfaces and same surface) 1	15	80		85	90	95
	n	$15 + 40 \frac{(n-2)}{2}$ (n = 2, 4, 6, 8... Note 1)	$80 + 40 \frac{(n-4)}{2}$ (n = 4, 8, 12, 16... Note 2)		$85 + 40 \frac{(n-4)}{2}$ (n = 4, 8, 12, 16... Note 2)	$90 + 40 \frac{(n-4)}{2}$ (n = 4, 8, 12, 16... Note 2)	$95 + 40 \frac{(n-4)}{2}$ (n = 4, 8, 12, 16... Note 2)
D-M9□V D-M9□WV	2 (Different surfaces and same surface) 1	10	55		60	65	70
	n	$10 + 30 \frac{(n-2)}{2}$ (n = 2, 4, 6, 8... Note 1)	$55 + 30 \frac{(n-4)}{2}$ (n = 4, 8, 12, 16... Note 2)		$60 + 30 \frac{(n-4)}{2}$ (n = 4, 8, 12, 16... Note 2)	$65 + 30 \frac{(n-4)}{2}$ (n = 4, 8, 12, 16... Note 2)	$70 + 30 \frac{(n-4)}{2}$ (n = 4, 8, 12, 16... Note 2)
D-M9□A	2 (Different surfaces and same surface) 1	15	80		85	95	100
	n	$15 + 40 \frac{(n-2)}{2}$ (n = 2, 4, 6, 8... Note 1)	$80 + 40 \frac{(n-4)}{2}$ (n = 4, 8, 12, 16... Note 2)		$85 + 40 \frac{(n-4)}{2}$ (n = 4, 8, 12, 16... Note 2)	$95 + 40 \frac{(n-4)}{2}$ (n = 4, 8, 12, 16... Note 2)	$100 + 40 \frac{(n-4)}{2}$ (n = 4, 8, 12, 16... Note 2)
D-M9□AV	2 (Different surfaces and same surface) 1	10	60		65	70	75
	n	$10 + 30 \frac{(n-2)}{2}$ (n = 2, 4, 6, 8... Note 1)	$60 + 30 \frac{(n-4)}{2}$ (n = 4, 8, 12, 16... Note 2)		$65 + 30 \frac{(n-4)}{2}$ (n = 4, 8, 12, 16... Note 2)	$70 + 30 \frac{(n-4)}{2}$ (n = 4, 8, 12, 16... Note 2)	$75 + 30 \frac{(n-4)}{2}$ (n = 4, 8, 12, 16... Note 2)
D-A9□	2 (Different surfaces and same surface) 1	15	75		80	85	90
	n	$15 + 40 \frac{(n-2)}{2}$ (n = 2, 4, 6, 8... Note 1)	$75 + 40 \frac{(n-4)}{2}$ (n = 4, 8, 12, 16... Note 2)		$80 + 40 \frac{(n-4)}{2}$ (n = 4, 8, 12, 16... Note 2)	$85 + 40 \frac{(n-4)}{2}$ (n = 4, 8, 12, 16... Note 2)	$90 + 40 \frac{(n-4)}{2}$ (n = 4, 8, 12, 16... Note 2)
D-A9□V	2 (Different surfaces and same surface) 1	10	50		55	60	65
	n	$10 + 30 \frac{(n-2)}{2}$ (n = 2, 4, 6, 8... Note 1)	$50 + 30 \frac{(n-4)}{2}$ (n = 4, 8, 12, 16... Note 2)		$55 + 30 \frac{(n-4)}{2}$ (n = 4, 8, 12, 16... Note 2)	$60 + 30 \frac{(n-4)}{2}$ (n = 4, 8, 12, 16... Note 2)	$65 + 30 \frac{(n-4)}{2}$ (n = 4, 8, 12, 16... Note 2)
D-F5□/J59 D-F5□W/J59W D-F5BA/F59F D-A5□/A6	2 (Different surfaces and same surface) 1	15	90		100	110	120
	n (Same surface)	$15 + 55 \frac{(n-2)}{2}$ (n = 2, 4, 6, 8... Note 1)	$90 + 55 \frac{(n-4)}{2}$ (n = 4, 8, 12, 16... Note 2)		$100 + 55 \frac{(n-4)}{2}$ (n = 4, 8, 12, 16... Note 2)	$110 + 55 \frac{(n-4)}{2}$ (n = 4, 8, 12, 16... Note 2)	$120 + 55 \frac{(n-4)}{2}$ (n = 4, 8, 12, 16... Note 2)
D-F5NT	2 (Different surfaces and same surface) 1	25	110		120	130	140
	n (Same surface)	$25 + 55 \frac{(n-2)}{2}$ (n = 2, 4, 6, 8... Note 1)	$110 + 55 \frac{(n-4)}{2}$ (n = 4, 8, 12, 16... Note 2)		$120 + 55 \frac{(n-4)}{2}$ (n = 4, 8, 12, 16... Note 2)	$130 + 55 \frac{(n-4)}{2}$ (n = 4, 8, 12, 16... Note 2)	$140 + 55 \frac{(n-4)}{2}$ (n = 4, 8, 12, 16... Note 2)
D-A59W	2 (Different surfaces and same surface) 1	20	90		100	110	120
	n (Same surface)	$20 + 55 \frac{(n-2)}{2}$ (n = 2, 4, 6, 8... Note 1)	$90 + 55 \frac{(n-4)}{2}$ (n = 4, 8, 12, 16... Note 2)		$100 + 55 \frac{(n-4)}{2}$ (n = 4, 8, 12, 16... Note 2)	$110 + 55 \frac{(n-4)}{2}$ (n = 4, 8, 12, 16... Note 2)	$120 + 55 \frac{(n-4)}{2}$ (n = 4, 8, 12, 16... Note 2)
D-G5□/K59 D-G5□W D-K59W D-G5BA D-G59F D-G5NT D-B5□/B64	1	15	90		100	110	120
	2	Different surfaces	15	90	100	110	
		Same surface	75				
	n	Different surfaces	$15 + 50 \frac{(n-2)}{2}$ (n = 2, 4, 6, 8... Note 1)	$90 + 50 \frac{(n-4)}{2}$ (n = 4, 8, 12, 16... Note 2)		$100 + 50 \frac{(n-4)}{2}$ (n = 4, 8, 12, 16... Note 2)	$110 + 50 \frac{(n-4)}{2}$ (n = 4, 8, 12, 16... Note 2)
		Same surface	$75 + 50 (n-2)$ (n = 2, 3, 4...)	$90 + 50 (n-2)$ (n = 2, 4, 6, 8... Note 1)		$100 + 50 (n-2)$ (n = 2, 4, 6, 8... Note 1)	$110 + 50 (n-2)$ (n = 2, 4, 6, 8... Note 1)
1	10	90		100	110		
D-B59W	2	Different surfaces	20	90	100	110	
		Same surface	75				
	n	Different surfaces	$20 + 50 \frac{(n-2)}{2}$ (n = 2, 4, 6, 8... Note 1)	$90 + 50 \frac{(n-4)}{2}$ (n = 4, 8, 12, 16... Note 2)		$100 + 50 \frac{(n-4)}{2}$ (n = 4, 8, 12, 16... Note 2)	$110 + 50 \frac{(n-4)}{2}$ (n = 4, 8, 12, 16... Note 2)
		Same surface	$75 + 50 (n-2)$ (n = 2, 2, 3, 4...)	$90 + 50 (n-2)$ (n = 2, 4, 6, 8... Note 1)		$100 + 50 (n-2)$ (n = 2, 4, 6, 8... Note 1)	$110 + 50 (n-2)$ (n = 2, 4, 6, 8... Note 1)
1	15	90		100	110		

Note 1) When "n" is an odd number, an even number that is one larger than this odd number is used for the calculation.
 Note 2) When "n" is an odd number, a multiple of 4 that is larger than this odd number is used for the calculation.

Minimum Stroke for Auto Switch Mounting (Standard Type)

n: Number of auto switches (mm)

Auto switch model	Number of auto switches	Brackets other than center trunnion	Center trunnion				
			ø40	ø50	ø63	ø80	ø100
D-G39 D-K39 D-A3□	2	Different surfaces	35	75	80	90	
		Same surface	100	100	100	100	
	n	Different surfaces	35 + 30 (n - 2) (n = 2, 3, 4...)	75 + 30 (n - 2) (n = 2, 4, 6, 8...) ^{Note 1)}	80 + 30 (n - 2) (n = 2, 4, 6, 8...) ^{Note 1)}	90 + 30 (n - 2) (n = 2, 4, 6, 8...) ^{Note 1)}	
		Same surface	100 + 100 (n - 2) (n = 2, 3, 4...)		100 + 100 (n - 2) (n = 2, 4, 6, 8...) ^{Note 1)}		
	1	10	75	80	90		
D-A44	2	Different surfaces	35	75	80	90	
		Same surface	55				
	n	Different surfaces	35 + 30 (n - 2) (n = 2, 3, 4...)	75 + 30 (n - 2) (n = 2, 4, 6, 8...) ^{Note 1)}	80 + 30 (n - 2) (n = 2, 4, 6, 8...) ^{Note 1)}	90 + 30 (n - 2) (n = 2, 4, 6, 8...) ^{Note 1)}	
		Same surface	55 + 50 (n - 2) (n = 2, 3, 4...)	75 + 50 (n - 2) (n = 2, 4, 6, 8...) ^{Note 1)}	80 + 50 (n - 2) (n = 2, 4, 6, 8...) ^{Note 1)}	90 + 50 (n - 2) (n = 2, 4, 6, 8...) ^{Note 1)}	
	1	10	75	80	90		
D-G39C D-K39C D-A3□C	2	Different surfaces	20	75	80	90	
		Same surface	100	100	100	100	
	n	Different surfaces	20 + 35 (n - 2) (n = 2, 3, 4...)	75 + 35 (n - 2) (n = 2, 4, 6, 8...) ^{Note 1)}	80 + 35 (n - 2) (n = 2, 4, 6, 8...) ^{Note 1)}	90 + 35 (n - 2) (n = 2, 4, 6, 8...) ^{Note 1)}	
		Same surface	100 + 100 (n - 2) (n = 2, 3, 4, 5...)		100 + 100 (n - 2) (n = 2, 4, 6, 8...) ^{Note 1)}		
	1	10	75	80	90		
D-A44C	2	Different surfaces	20	75	80	90	
		Same surface	55				
	n	Different surfaces	20 + 35 (n - 2) (n = 2, 3, 4...)	75 + 35 (n - 2) (n = 2, 4, 6, 8...) ^{Note 1)}	80 + 35 (n - 2) (n = 2, 4, 6, 8...) ^{Note 1)}	90 + 35 (n - 2) (n = 2, 4, 6, 8...) ^{Note 1)}	
		Same surface	55 + 50 (n - 2) (n = 2, 3, 4...)	75 + 50 (n - 2) (n = 2, 4, 6, 8...) ^{Note 1)}	80 + 50 (n - 2) (n = 2, 4, 6, 8...) ^{Note 1)}	90 + 50 (n - 2) (n = 2, 4, 6, 8...) ^{Note 1)}	
	1	10	75	80	90		
D-Y59□/Y7P D-Y7□W D-Z7□/Z80	2 (Different surfaces and same surface) 1	15	80	85	90	95	105
	n	15 + 40 $\frac{(n-2)}{2}$ (n = 2, 4, 6, 8...) ^{Note 1)}	80 + 40 $\frac{(n-4)}{2}$ (n = 4, 8, 12, 16...) ^{Note 2)}	85 + 40 $\frac{(n-4)}{2}$ (n = 4, 8, 12, 16...) ^{Note 2)}	90 + 40 $\frac{(n-4)}{2}$ (n = 4, 8, 12, 16...) ^{Note 2)}	95 + 40 $\frac{(n-4)}{2}$ (n = 4, 8, 12, 16...) ^{Note 2)}	105 + 40 $\frac{(n-4)}{2}$ (n = 4, 8, 12, 16...) ^{Note 2)}
D-Y69□/Y7PV D-Y7□WV	2 (Different surfaces and same surface) 1	10	65	75	80	90	
	n	10 + 30 $\frac{(n-2)}{2}$ (n = 2, 4, 6, 8...) ^{Note 1)}	65 + 30 $\frac{(n-4)}{2}$ (n = 4, 8, 12, 16...) ^{Note 2)}	75 + 30 $\frac{(n-4)}{2}$ (n = 4, 8, 12, 16...) ^{Note 2)}	80 + 30 $\frac{(n-4)}{2}$ (n = 4, 8, 12, 16...) ^{Note 2)}	90 + 30 $\frac{(n-4)}{2}$ (n = 4, 8, 12, 16...) ^{Note 2)}	
D-Y7BA	2 (Different surfaces and same surface) 1	20	95	100	105	110	
	n	20 + 45 $\frac{(n-2)}{2}$ (n = 2, 4, 6, 8...) ^{Note 1)}	95 + 45 $\frac{(n-4)}{2}$ (n = 4, 8, 12, 16...) ^{Note 2)}	100 + 45 $\frac{(n-4)}{2}$ (n = 4, 8, 12, 16...) ^{Note 2)}	105 + 45 $\frac{(n-4)}{2}$ (n = 4, 8, 12, 16...) ^{Note 2)}	110 + 45 $\frac{(n-4)}{2}$ (n = 4, 8, 12, 16...) ^{Note 2)}	

Note 1) When "n" is an odd number, an even number that is one larger than this odd number is used for the calculation.

Note 2) When "n" is an odd number, a multiple of 4 that is larger than this odd number is used for the calculation.

CVS1 Series

Operating Range

Auto switch model	Bore size (mm)				
	40	50	63	80	100
D-M9□/M9□V D-M9□W/M9□WV D-M9□A/M9□AV	4.5	5	5.5	5	6
D-A9□/A9□V	7	—	9	9	9
D-Z7□/Z80	8	7	9	9.5	10.5
D-A3□/A44 D-A3□C/A44C	9	10	11	11	11
D-A5□/A6□					
D-B5□/B64					
D-A59W	13	13	14	14	15
D-B59W	14	14	17	16	18
D-Y59□/Y69□ D-Y7P/Y7PV D-Y7□W/Y7□WV	8	7	5.5	6.5	6.5
D-F5□/J59 D-F5□W/J59W D-F5NT/F59F	4	4	4.5	4.5	4.5
D-G5□/K59 D-G5□W/K59W D-G5NT/G59F	5	6	6.5	6.5	7
D-G39/K39 D-G39C/K39C	9	9	10	10	11

* D-A9□ and D-A9□V types cannot be mounted on ø50
 * Since this is a guideline including hysteresis, not meant to be guaranteed. (Assuming approximately ±30% dispersion.)
 There may be the case it will vary substantially depending on an ambient environment.

Auto Switch Mounting Bracket Part No.

<Tie-rod mounting type>

Auto switch model	Bore size (mm)				
	40	50	63	80	100
D-M9□/M9□V D-M9□W/M9□WV D-M9□A/M9□AV D-A9□/A9□V	BA7-040	BA7-040	BA7-063	BA7-080	BA7-080
D-F5□/J59 D-F5□W/J59W D-F59F/F5NT D-A5□/A6□ D-A59W	BT-04	BT-04	BT-06	BT-08	BT-08
D-G39C/K39C D-A3□C/A44C	BA3-040	BA3-050	BA3-063	BA3-080	BA3-100
D-Y59□/Y69□ D-Y7P/Y7PV D-Y7□W/Y7□WV D-Y7BA D-Z7□/Z80	BA4-040	BA4-040	BA4-063	BA4-080	BA4-080

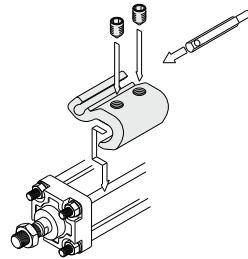

* The figure shows the mounting example for the D-M9□(V)/M9□W(V)/M9□A(V)/A9□(V) types.

<Band mounting type>

Standard

Auto switch model	Bore size (mm)				
	40	50	63	80	100
D-G39/K39 D-A3□/A44	BDS-04M	BDS-05M	BMB1-063	BMB1-080	BMB1-100
D-G5□/K59 D-G5□W/K59W D-G59F D-G5NT D-B5□/B64 D-B59W	BH2-040	BA5-050	BAF-06	BAF-08	BAF-10

Note 1) Auto switch brackets are included in the D-A3□C/A44C/G39C/K39C types. Specify the part number as follows depending on the cylinder size when ordering.
 (Example) ø40: D-A3□C-4, ø50: D-A3□C-5, ø63: D-A3□C-6, ø80: D-A3□C-8, ø100: D-A3□C-10

Other than the models listed in "How to Order", the following auto switches are applicable.
 For detailed specifications, refer to pages 1341 to 1435.

Auto switch type	Model	Electrical entry (Fetching direction)	Features
Reed	D-A93V, A96V	Grommet (Perpendicular)	—
	D-A90V		Without indicator light
	D-A53, A56, B53, Z73, Z76	Grommet (In-line)	—
	D-A67, Z80		Without indicator light
Solid state	D-M9NV, M9PV, M9BV	Grommet (Perpendicular)	—
	D-Y69A, Y69B, Y7PV		Diagnostic indication (2-color indicator)
	D-M9NWW, M9PWV, M9BWW		Water resistant (2-color indicator)
	D-Y7NWW, Y7PWW, Y7BWW		—
	D-M9NAV, M9PAV, M9BAV		—
	D-Y59A, Y59B, Y7P	Grommet (In-line)	—
	D-F59, F5P, J59		Diagnostic indication (2-color indicator)
	D-Y7NW, Y7PW, Y7BW		With timer
	D-F59W, F5PW, J59W		—
	D-F5NT, G5NT		—
			—

* With pre-wired connector is also available in solid state auto switches. For details, refer to pages 1410 and 1411.

* Normally closed (NC = b contact) solid state auto switches (D-M9□E(V)/Y7G/Y7H) are also available. For details, refer to pages 1360 and 1362.



CVS1 Series Specific Product Precautions

Be sure to read this before handling the products. Refer to page 9 for safety instructions, pages 10 to 19 for actuator and auto switch precautions, and 3/4/5-port solenoid valve precautions on the SMC website: <https://www.smcworld.com>

Selection

⚠ Warning

1. Confirm the specifications.

Products in this catalog are designed to be used for compressed air systems. If not operated within the designated pressure or temperature, it may damage the products or cause malfunction. (Refer to specifications.)

2. Energizing continuously for a long period of time

When the valve is continuously energized for a long period of time, the performance may deteriorate or effect peripheral equipment adversely since temperature rises when coils generate heat.

3. Mounting orientation

Metal seal: For single solenoids, mounting orientation is flexible. For double solenoids and 3 position valves, mount a spool valve horizontally.

Handling

⚠ Warning

1. Do not open the cushion valve beyond the stopper.

A retaining ring is installed as a cushion valve retention mechanism. Do not open the cushion valve beyond it. If not operated in accordance with the above precautions, the cushion valve may be ejected from the cover when air pressure is supplied.

Bore size (mm)	Width across flats	Socket wrench
40, 50	2.5	JIS 4648 Hexagonal wrench key 2.5
63, 80, 100	4	JIS 4648 Hexagonal wrench key 4

2. Use the air cushion at the end of cylinder stroke.

Otherwise, the tie-rod or piston rod assembly will be damaged.

Handling

⚠ Caution

1. Do not use a pneumatic type as an air-hydro cylinder. It can cause oil leak.

2. Do not rotate the piston rod when the rod boot is fixed.

Before rotating the piston rod, loosen the band to avoid twisting the rod boot.

3. Install the rod boot with the breathing hole facing downwards or in a direction suitable to prevent dust, moisture etc. from entering easily into the rod boot.

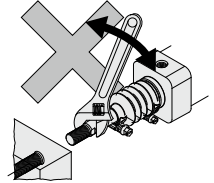

Disassembly/Replacement

⚠ Caution

1. Use a socket wrench when the bracket is replaced.

If other tools are used, the nut or other parts may be deformed or the work efficiency may decrease. For applicable sockets, refer to the table below.

Bore size (mm)	Nut	Width across flats	Socket	Tightening torque (N·m)
40, 50	DA00040	13	JIS B4636	7.4
	(M8 x 1.25, Hexagon nut 3 types)		+ Two-angle socket 13	
63	DA00010	17	JIS B4636	20
	(M10 x 1.25, Hexagon nut 3 types)		+ Two-angle socket 17	
80, 100	DA00131	19	JIS B4636	29
	(M12 x 1.75, Hexagon nut 3 types)		+ Two-angle socket 19	

2. Do not replace the bushing.

As the bushing is press-fit, replace the cover assembly when the bushing must be replaced.

3. When a seal is replaced, apply grease to the new seal before it is assembled.

Operation of the cylinder without greasing will result in extreme abrasion of the seal, causing premature air leakage.

4. Do not disassemble the trunnion type cylinder because the mounting precision is required.

It is difficult to align the axial center of the trunnion with the axial center of the cylinder. Thus, if this type of cylinder is disassembled and reassembled, the required dimensional accuracy cannot be attained, which may lead to malfunctions.