

Mini Rotary Actuator/Rack & Pinion Style

Series *CRJ*

Size: 05, 1

More Compact.



PAT. PEND

CRB2

CRBU2

CRB1

MSU

CRJ

CRA1

CRQ2

MSQ

MSZ

CRQ2X
MSQX

MRQ

D-□

Mini Rotary Actuator *Series CRJ*

Rack & Pinion Style/Size: 05, 1

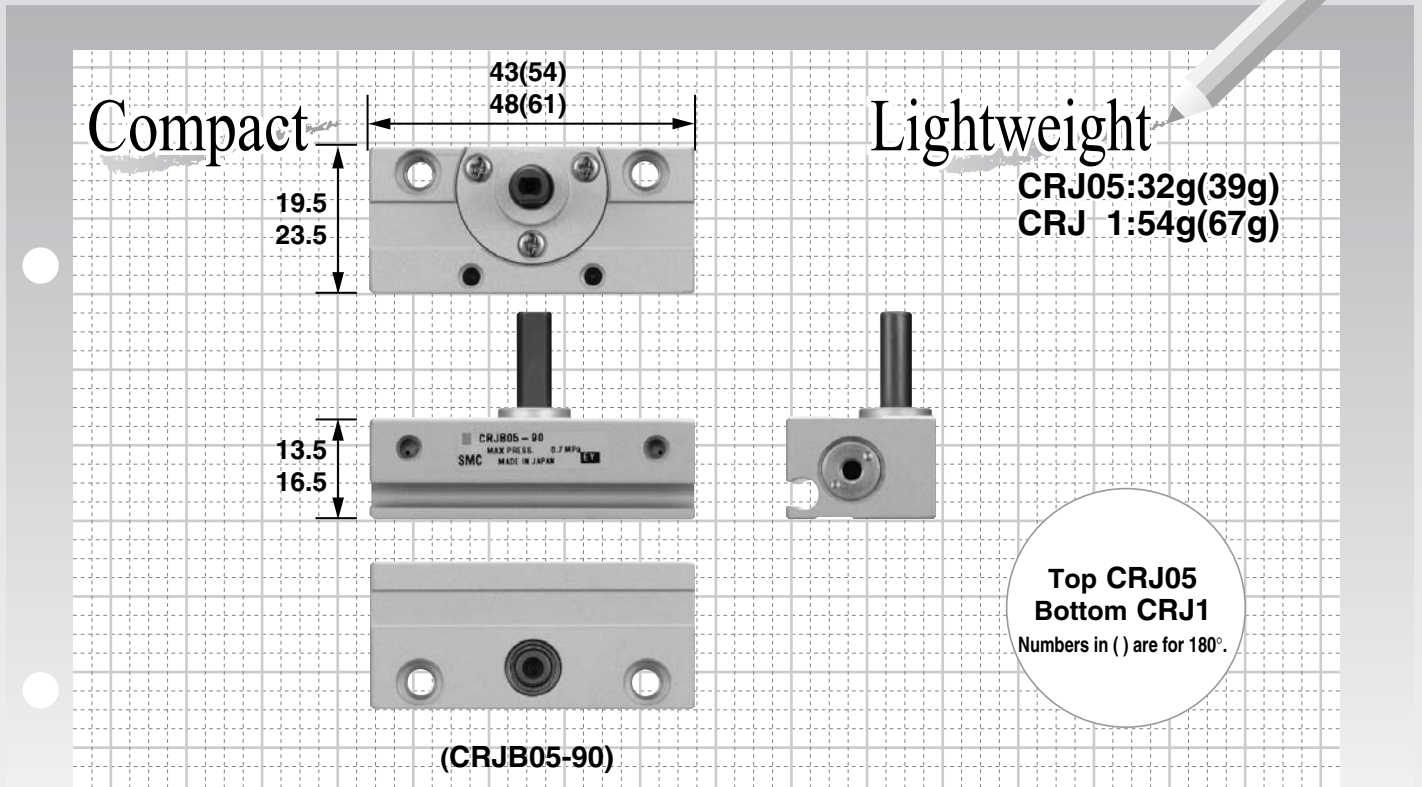

Flexible mounting

A new compact body design not only reduces overall space requirements, but also achieves space-savings in wiring and piping. Ease in mounting is maximized thanks to the merits of the new compact body.

■ Free mounting

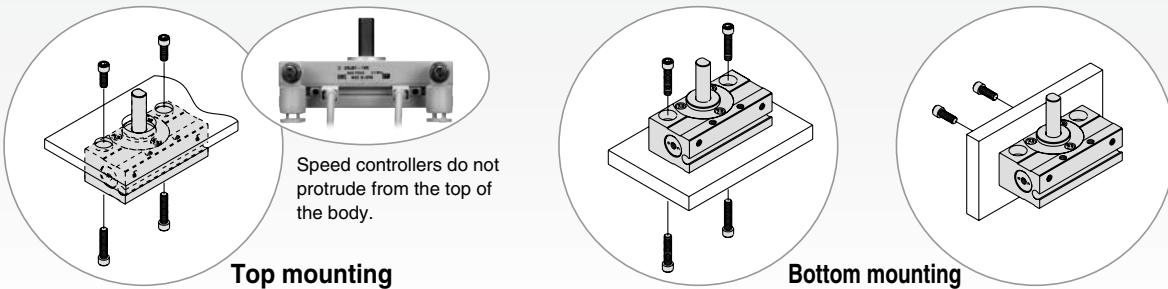

■ Wiring and piping direction can be selected depending on mounting conditions.

Mounting examples for auto switch and speed controller



Allowable load improved

Large roller bearing and large diameter output shaft add to overall compactness while ensuring high rigidity.

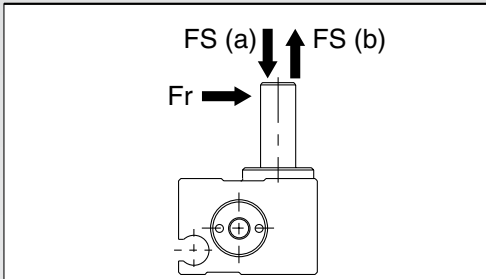
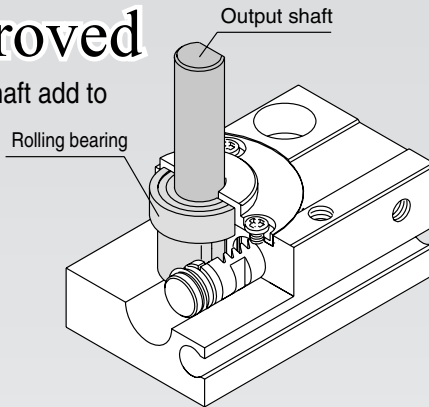

Model		CRJ05	CRJ1
Allowable load (N)	Fr	25	30
	FS (a)	20	25
	FS (b)	20	25
Output shaft size (mm)		ø5	ø6

Backlash reduced

Even with a single rack design, the use of a special construction minimizes backlash.

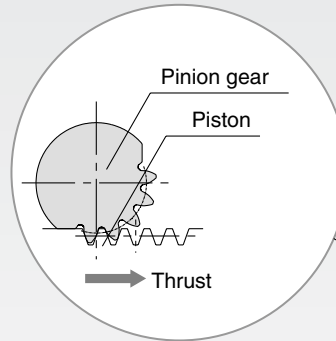

Stopping the pinion gear by having it strike against the flat surface of the piston eliminates backlash.

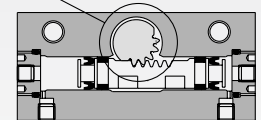

With external stopper/Series CRJU

4 to 5 times allowable kinetic energy (Basic type compared to CRJB)

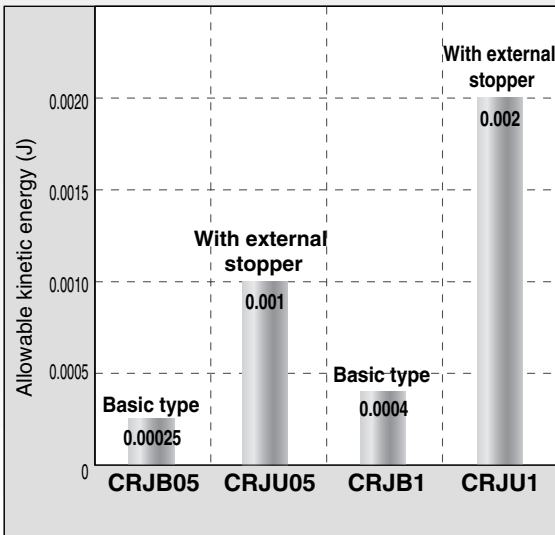

Angle is adjustable: $\pm 5^\circ$ at each rotation end

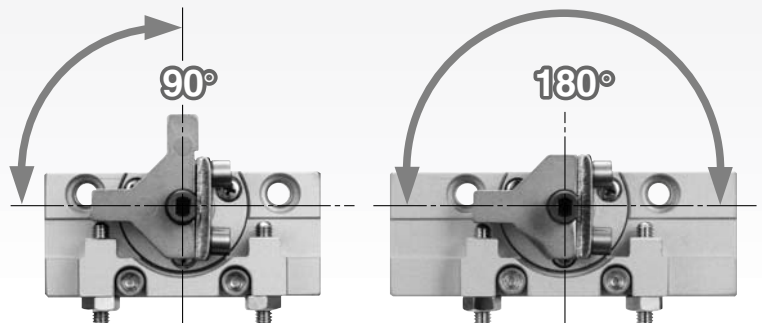

Series Variations

Series		Rotating angle				Connection port location	Auto switch
		90°	100°	180°	190°		
Basic type	CRJB05	●	●	●	●	Front ported Side ported	D-F8 type D-M9/M9□V type D-M9□W/M9□WV type
	CRJB 1	●	●	●	●		
With external stopper	CRJU05	●	—	●	—		
	CRJU 1	●	—	●	—		

CRB2

CRBU2

CRB1

MSU

CRJ

CRA1

CRQ2

MSQ

MSZ

CRQ2X

MSQX

MRQ

D-□

Mini Rotary Actuator Rack & Pinion Style Series CRJ

How to Order

Rotating angle

90	90°
100	100°
180	180°
190	190°

Basic type CRJ B **05** - **90** - **M9BW** -

With external stopper CRJ U **05** - **90** - **M9BW** -

Pattern

Nil	Standard
P	Simple Specials/Made to Order

*Refer to pages 188 and 189 for details.

Size

05
1

Rotating angle

90	90°
180	180°

Made to Order
Refer to page 183 for details.

Number of auto switches

S	1 pc.
Nil	2 pcs.

Note) Maximum number of auto switches mountable is two.

Auto switch

Nil	Without auto switch (Built-in magnet)
-----	---------------------------------------

* For the applicable auto switch model, refer to the table below.

Connection port location

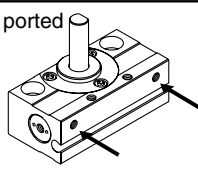
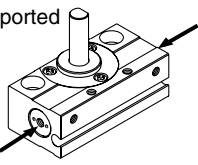
Nil	Front ported	
E	Side ported	

Applicable Auto Switch/Refer to pages 761 to 809 for further information on auto switches.

Type	Special function	Electrical entry	Indicator light	Wiring (Output)	Load voltage		Auto switch model		Lead wire length (m)*				Pre-wired connector	Applicable load				
					DC	AC	Perpendicular entry	In-line entry	0.5 (Nil)	1 (M)	3 (L)	5 (Z)						
Solid state switch	—	Grommet	Yes	3-wire (NPN)	24V	5V, 12V	—	M9NV	M9N	●	●	●	○	○	IC circuit			
								F8N	—	●	—	●	○	—				
				M9PV				M9P	●	●	●	○	○					
				F8P				—	●	—	●	○	—					
				M9BV				M9B	●	●	●	○	○					
				F8B				—	●	—	●	○	—					
	Diagnosis indication (2-color)			3-wire (NPN)	5V, 12V	—	M9NWV	M9NW	●	●	●	○	○	○	○	IC circuit		
							M9PWV	M9PW	●	●	●	○	○	○	○			
				2-wire			12V	M9BWV	M9BW	●	●	●	○	○	○	○	—	
								M9NAV**	M9NA**	○	○	●	○	○	○	○	IC circuit	
				3-wire (PNP)			5V, 12V	M9PAV**	M9PA**	○	○	●	○	○	○	○	○	IC circuit
								M9BAV**	M9BA**	○	○	●	○	○	○	○	○	—

** Although it is possible to mount water-resistant type auto switches, note that the rotary actuator itself is not of water-resistant construction.

* Lead wire length symbols: 0.5 m Nil (Example) M9NW * Auto switches marked "○" are produced upon receipt of order.

1 m M (Example) M9NWM

3 m L (Example) M9NWL

5 m Z (Example) F9NWX

 Refer to pages 796 and 797 for detailed solid state auto switches with pre-wired connectors.

Note 1) When using a D-F8□ switch, mount it at a distance of 10 mm or more from magnetic substances such as iron, etc.

* Auto switches are shipped together, but not assembled.

Specifications



Size	05		1	
	Basic type	With external stopper	Basic type	With external stopper
Fluid	Air (Non-lube)			
Max. operating pressure	0.7 MPa			
Min. operating pressure	0.15 MPa			
Ambient and fluid temperature	0 to 60°C (No freezing)			
Rotating angle ^(Note)	90° ^{+8°} ₀ , 100° ^{+10°} ₀ 180° ^{+8°} ₀ , 190° ^{+10°} ₀	90°, 180°	90° ^{+8°} ₀ , 100° ^{+10°} ₀ 180° ^{+8°} ₀ , 190° ^{+10°} ₀	90°, 180°
Angle adjustment range	—	±5° at each rotation end	—	±5° at each rotation end
Cylinder bore size	ø6		ø8	
Port size	M3 x 0.5			

Note) If optimum accuracy of the (rotating) angle is required, select an actuator with external stopper.



Made to Order
(Refer to pages 188 and 189 for details.)

Symbol	Specifications/Description
-XA1 to XA17	Shaft Pattern Sequencing I

JIS Symbol

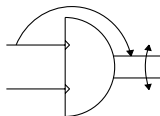

Allowable Kinetic Energy and Rotation Time Adjustment Range

Size		Allowable kinetic energy (J)	Rotation time adjustment range for stable operation (s/90°)
05	Basic type CRJB05	0.00025	0.1 to 0.5
	With external stopper CRJU05	0.001	
1	Basic type CRJB1	0.0004	
	With external stopper CRJU1	0.002	

Mass

Type	Model	Mass (g) ^(Note)
Basic type	05	CRJB05-90
		CRJB05-100
		CRJB05-180
	1	CRJB1-90
		CRJB1-100
		CRJB1-180
With external stopper	05	CRJU05-90
		CRJU05-180
	1	CRJU1-90
		CRJU1-180

Note) Values above do not include auto switch mass.

CRB2

CRBU2

CRB1

MSU

CRJ

CRA1

CRQ2

MSQ

MSZ

CRQ2X
MSQX

MRQ

D-□

Series CRJ

Rotating Direction and Rotating Angle

- The shaft turns clockwise when the A port is pressurized, and counterclockwise when the B port is pressurized.
- For actuators with external stopper, the rotation end can be set within the ranges shown in the drawing by adjusting the stopper bolt.

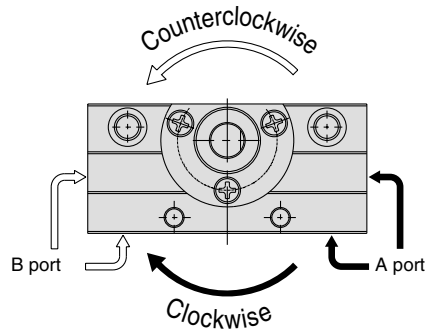

Basic type

For 90° and 100°

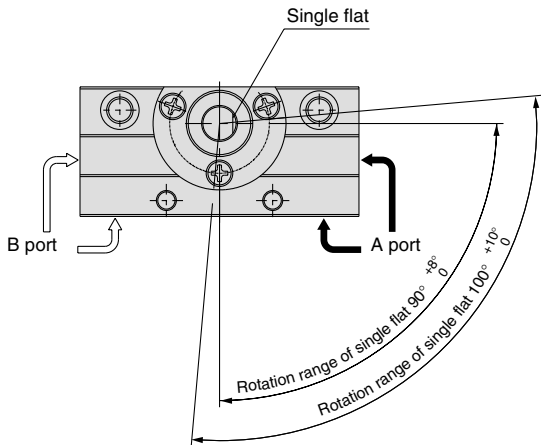

For 180° and 190°

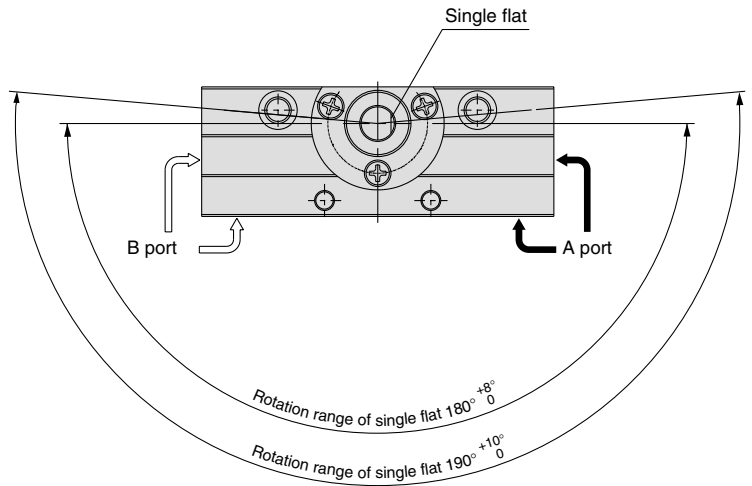

With external stopper

For 90°

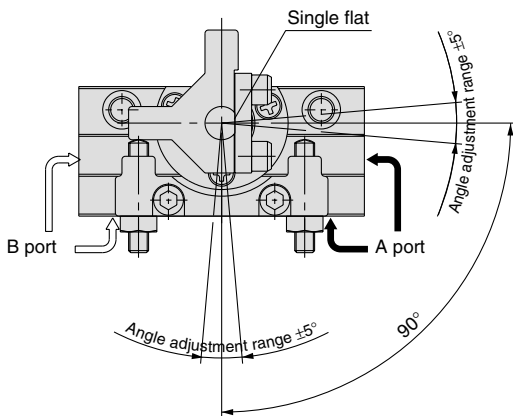

For 180°

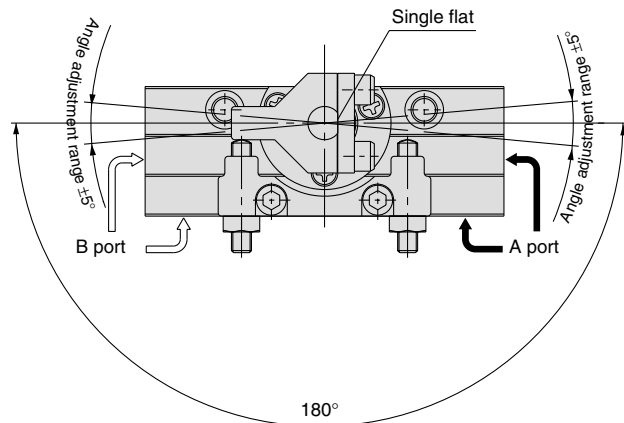

- Note) • The drawings show the rotation range for the shaft's single flat.
 • The single flat position in the drawings shows the counterclockwise rotation end when the rotation angle is adjusted to 90° and 180°.

Construction

Basic type: CRJB

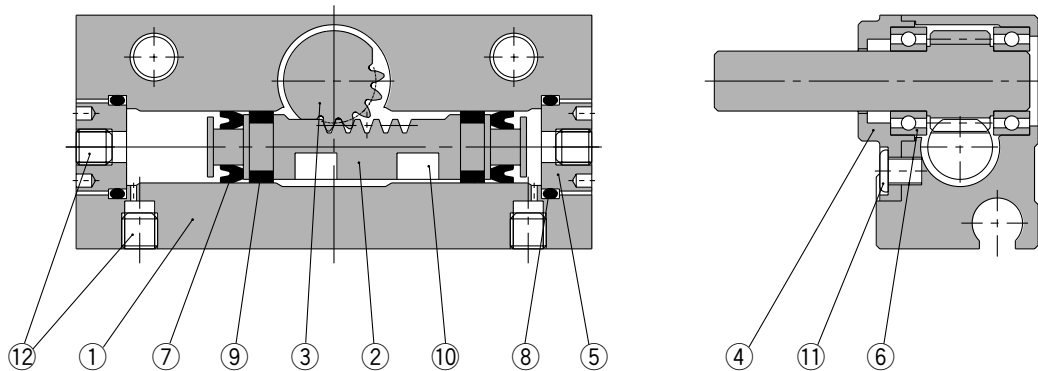

With external stopper: CRJU

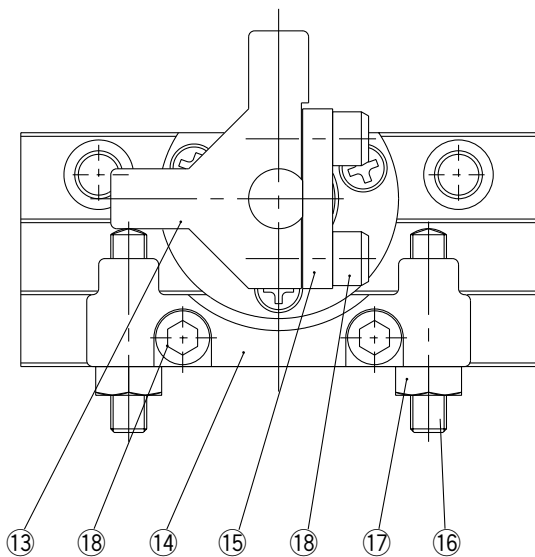

CRB2

CRBU2

CRB1

MSU

CRJ

CRA1

CRQ2

MSQ

MSZ

CRQ2X
MSQX

MRQ

Component Parts

No.	Description	Material	Note
①	Body	Aluminum alloy	Anodized
②	Piston	Stainless steel	
③	Shaft	Stainless steel	
④	Bearing retainer *	Aluminum alloy	Anodized
⑤	Cover	Aluminum alloy	Anodized
⑥	Bearing	Bearing steel	
⑦	Piston seal	NBR	
⑧	O-ring	NBR	
⑨	Wear ring	Resin	

No.	Description	Material	Note
⑩	Magnet	—	
⑪	Round head no. 0 Philips screw	Steel wire	Nickel plated
⑫	Hexagon socket head set screw	Stainless steel	
⑬	Stopper	Chrome molybdenum steel	Electroless nickel plated
⑭	Holder	Aluminum alloy	Anodized
⑮	Stopper retainer	Carbon steel	Zinc chromated
⑯	Hexagon socket head set screw	Steel wire	Nickel plated
⑰	Hexagon nut	Steel wire	Nickel plated
⑱	Hexagon socket head cap screw	Stainless steel	

* The mounting position of hexagon socket head set screws (No. 12) varies depending on the connecting port location.

D-□

Series CRJ

Dimensions/Size 05, 1

Basic type: CRJB

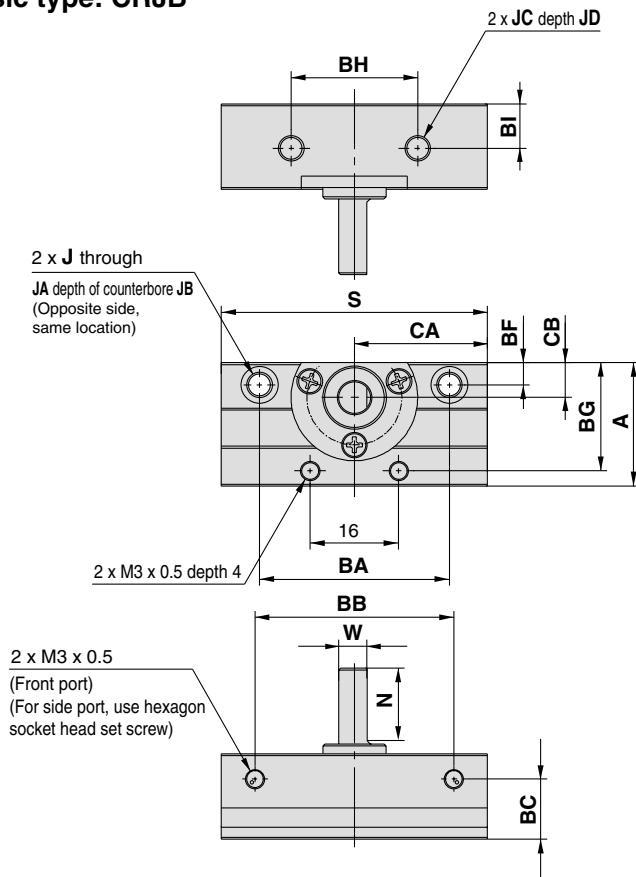

Note 1) This dimension is for the actuator with D-M9 type auto switch (not including the 2-color indication type).

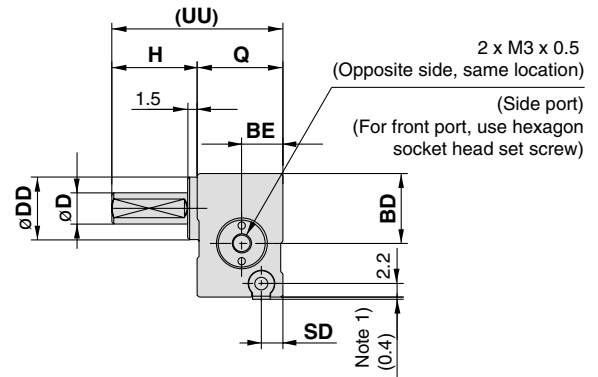

With external stopper: CRJU

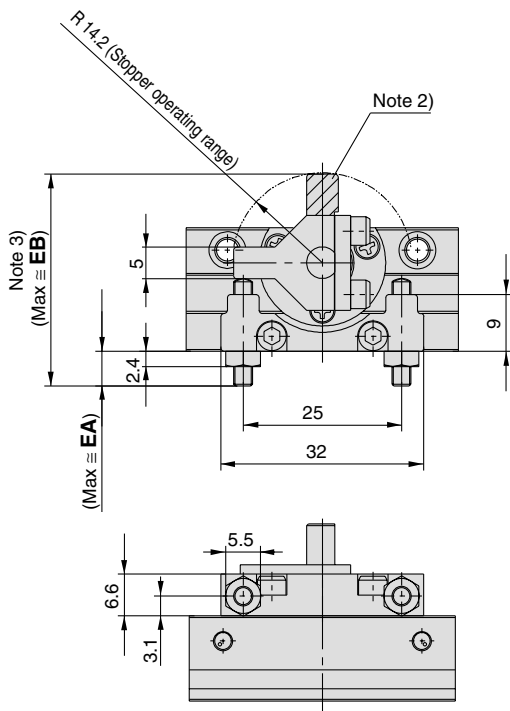

Note 2) For the 180° specification, the slated line area do not exist.

Note 3) The maximum dimensions that appear are those measured at the maximum rotating angle. settings: 100° and 190°.

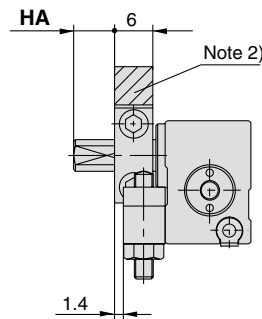

	(mm)		
Size	EA	EB	HA
CRJU05	5.6	33.8	6.5
CRJU1	5.6	35.8	7.5

Size	Rotating angle	(mm)																									
		A	BA	BB	BC	BD	BE	BF	BG	BH	BI	CA	CB	D	DD	J	JA	JB	JC	JD	H	N	Q	S	SD	UU	W
CRJB05	90°	19.5	30	32.4	9.5	11	6.5	3.5	17.1	20	7	21.5	5.5	5g6	10h9	M4 x 0.7	5.8	3.5	M4 x 0.7	5	14.5	12.5	13.5	43	3.4	28	4.5
	180°			43.4								27											54				
CRJB 1	90°	23.5	35	37.4	12.5	14	9	4.5	21.1	22	8.5	24	7.5	6g6	14h9	M5 x 0.8	7.5	4.5	M5 x 0.8	6	15.5	13.5	16.5	48	5.9	32	5.5
	180°			50.4								30.5											61				

Proper Auto Switch Mounting Position (Detection at rotation end)

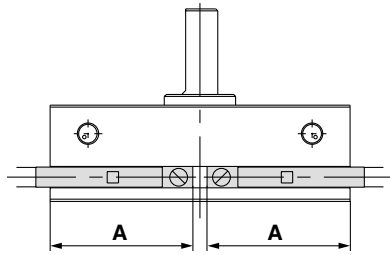

For D-M9

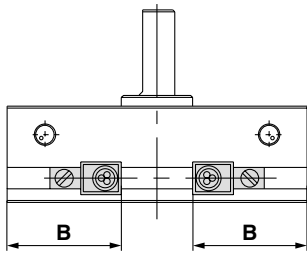

For D-F8

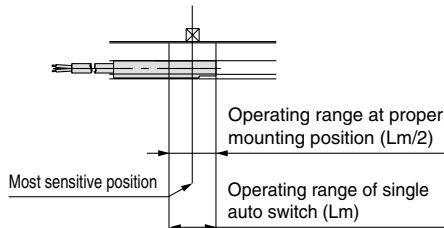

Size	Rotating angle	D-M9 auto switch			D-F8 auto switch		
		A	Operating angle θ m	Hysteresis angle	B	Operating angle θ m	Hysteresis angle
05	90°	20.5	40°	10°	16.5	20°	10°
	180°	23.2			19.2		
1	90°	22.4	30°	10°	18.4	15°	10°
	180°	25.6			21.6		

Operating angle θ m: Value of the operating range L_m of a single auto switch converted to an axial rotating angle.

Hysteresis angle : Value of auto switch hysteresis converted to an angle.

Note) The values given in the table above are representative values, not meant to be guaranteed.

In the actual setting, adjust the value after confirming the auto switch performance.

CRB2

CRBU2

CRB1

MSU

CRJ

CRA1

CRQ2

MSQ

MSZ

CRQ2X
MSQX

MRQ

D-□

Series CRJ (Size: 05, 1)

Simple Specials:

-XA1 to -XA17: Shaft Pattern Sequencing I

Shaft pattern sequencing is dealt with a simple made-to-order system. (Refer to front matter 33.)
Please contact SMC for a specification sheet when placing an order.

Shaft Pattern Sequencing I

How to Order

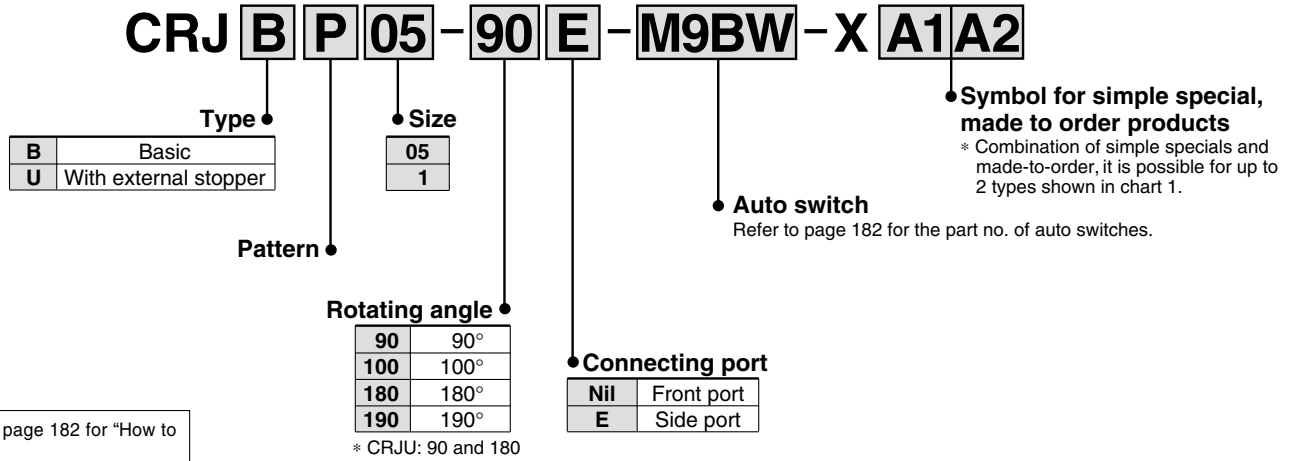

* Combination of simple specials and made-to-order, it is possible for up to 2 types shown in chart 1.

Combination Chart of Simple Specials for Tip End Shape

Chart 1. Combination between -XA□ and -XA□

Symbol	Description	Top port		Applicable size	Combination					
		Upper	Lower							
XA 1	Female thread at the end	●	—	05, 1	XA1					
XA 2	Female thread at the end	—	●		●	XA2				
XA13	Shaft through-hole	●	●		—	—	XA13			
XA14	Shaft through-hole and female thread at the end	●	—		—	—	—	XA14		
XA15	Shaft through-hole and female thread at the end	—	●		—	—	—	—	XA15	
XA16	Shaft through-hole and double shaft-end female thread	●	●		—	—	—	—	—	XA16
XA17	Shortened shaft	●	—		—	●	●	—	●	—

Series CRJ (Size: 05, 1)

Simple Specials:

-XA1 to -XA17: Shaft Pattern Sequencing I

Shaft pattern sequencing is dealt with a simple made-to-order system. (Refer to front matter 33.)
Please contact SMC for a specification sheet when placing an order.

Shaft Pattern Sequencing I

-XA1 to -XA17

Additional Reminders

1. Enter the dimensions within a range that allows for additional machining.
2. SMC will make appropriate arrangements if no dimensional, tolerance, or finish instructions are given in the diagram.
3. The length of the unthreaded portion is 2 to 3 pitches.
4. Unless specified otherwise, the thread pitch is based on coarse metric threads.
M3 x 0.5, M4 x 0.7

5. Enter the desired figures in the [] portion of the diagram.
6. Chamfer face of the parts machining additionally is C0.5.
7. The additionally machined port will have an aluminum surface since it is left unfinished.

A1

The long shaft can be further shortened by machining female threads into it. (If shortening the shaft is not required, indicate "*" for dimension X.)

- The maximum dimension L1 is, as a rule, twice the thread size (Example) For M3: L1 = 6

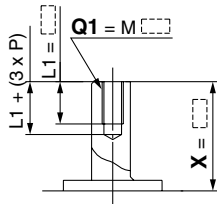

Size	X	Q1
CRJB05	1.5 to 14.5	M3
CRJU05	8 to 14.5	M3
CRJB 1	1.5 to 15.5	M3,M4
CRJU 1	8 to 15.5	M3,M4

A15

A special end is machined onto the short shaft, and a through-hole is drilled into it. Female threads are machined into the through-hole, whose diameter is equivalent to the pilot hole diameter.

- The maximum dimension L2 is, as a rule, twice the thread size. (Example) For M4: L2 = 8

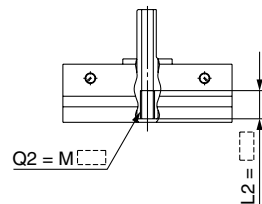

Size	05	1
M3 x 0.5	ø2.5	ø2.5
M4 x 0.7	—	ø3.3

A2

Machine female threads into the short shaft

- The maximum dimension L2 is, as a rule, twice the thread size. (Example) For M4: L2 = 8

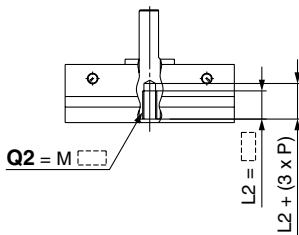

Size	Q2
05	M3
1	M3, M4

A16

A special end is machined onto both the long and short shafts, and a through-hole is drilled into both shafts. Female threads are machined into the through-holes, whose diameter is equivalent to the diameter of the pilot holes.

- The maximum dimension L1 is, as a rule, twice the thread size. (Example) For M3: L1 = 6
- Equal dimensions are indicated by the same marker.

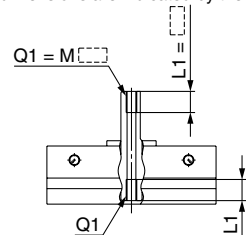

Size	05	1
M3 x 0.5	ø2.5	ø2.5
M4 x 0.7	—	ø3.3

A13

Shaft with through-hole
Minimum machining diameter for ød1 is 0.1.

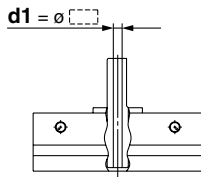

Size	d1
05	ø2 to ø2.5
1	ø2 to ø3.5

A17

Shorten the long shaft.

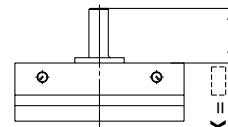

Size	X
CRJB05	1.5 to 14.5
CRJU05	8 to 14.5
CRJB 1	1.5 to 15.5
CRJU 1	8 to 15.5

A14

A special end is machined onto the long shaft, and a through-hole is drilled into it. Female threads are machined into the through-hole, whose diameter is equivalent to the pilot hole diameter.

- The maximum dimension L1 is, as a rule, twice the thread size. (Example) For M3: L1 = 6

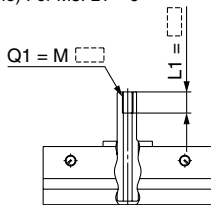

Size	05	1
M3 x 0.5	ø2.5	ø2.5
M4 x 0.7	—	ø3.3

CRB2

CRBU2

CRB1

MSU

CRJ

CRA1

CRQ2

MSQ

MSZ

CRQ2X
MSQX

MRQ

D-□



Series CRJ Specific Product Precautions

Be sure to read before handling.

Refer to front matters 38 and 39 for Safety Instructions and pages 4 to 13 for Rotary Actuator and Auto Switch Precautions.

Rotation Adjustment

⚠ Caution

As a standard feature, the actuator with external stopper is equipped with a rotation angle adjustment screw that can be used to adjust the angle of rotation.

Size	Angle adjustment per single rotation of angle adjustment screw
05	2.3°
1	2.3°

The rotation adjustment range for the actuator with external stopper is $\pm 5^\circ$ at each rotation end. Please note that adjusting beyond this range, may cause product malfunction.

Mounting of Speed Controller and Fittings

⚠ Caution

The M3 x 0.5 piping port is used. In case the speed controller or fittings are directly connected, use the series listed below.

- Speed controller
AS12□1F/Elbow type
AS13□1F/Universal type
- One-touch fitting
One-touch mini Series KJ
- Reducer bushing Series M3

Mounting of Auto Switch

⚠ Caution

If a size 05 actuator with auto switch is being used, keep the magnetic body away at least 2 mm or more from the bottom of the actuator.

If the magnetic body comes closer than 2 mm, malfunction of the auto switch may occur due to the magnetic force drop.

* When using the bottom face for mounting, a non-magnetic spacer (such as aluminum) is required as shown below.

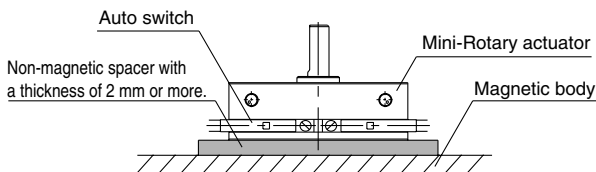

Maintenance

⚠ Caution

This product requires special tools; therefore, it cannot be disassembled for maintenance.

External Stopper Unit

⚠ Caution

Order external stopper unit with the unit part numbers shown below.

Parts List	
	Stopper
	Holder assembly
	Stopper retainer
	Hexagon socket head cap screw (set of 4)

Model	Unit part no.
CRJU05-90	P531010-1
CRJU05-180	P531010-2
CRJU1-90	P531020-1
CRJU1-180	P531020-2

Note 1) External stopper units for 180° cannot be applied to the 90° Mini-rotary Actuators.

Note 2) When using external stoppers for 90°, use Mini-rotary Actuators with a rotation range of 100°, and for 180°, use actuators with a rotation range of 190°.

External Stopper Assembly Procedure

* Actuators with external stopper (Model CRJU) come already assembled; therefore, the following procedure is not required.

⚠ Caution

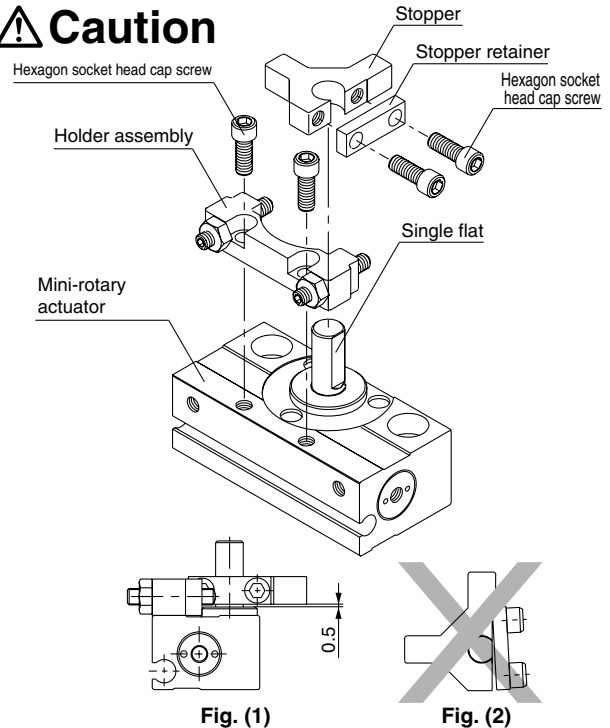

1. Assemble the stopper retainer to the stopper temporarily. Then place the stopper retainer in the single flat position and tighten with hexagon socket head cap screws. Leave a space of approximately 0.5 mm between the stopper and the Mini-rotary actuator, as shown in Fig. (1). Tighten the hexagon socket head cap screws evenly so that the stopper retainer is not unevenly tightened as in Fig. (2). Furthermore, take precautions to avoid applying excessive force to the shaft when tightening.
2. Tighten the holder assembly with hexagon socket head cap screws.

	Tightening torque (N·m)
Hexagon socket head cap screw	0.8 to 1.2



Rotary Actuators Precautions 1

Be sure to read this before handling.

Design / Selection

Warning

1. Confirm the specifications.

Products represented in this catalog are designed only for use in compressed air systems (including vacuum).

Do not operate at pressures or temperatures, etc., beyond the range of specifications, as this can cause damage or malfunction. (Refer to the specifications.)

Please contact SMC when using a fluid other than compressed air (including vacuum).

We do not guarantee against any damage if the product is used outside of the specification range.

2. If the operation involves load fluctuations, ascending/descending movements, or changes in frictional resistance, make sure to provide safety measures.

Operating speed will increase, and bodily injury may occur, or damage to the machinery itself may occur.

3. If there is a chance that the product will pose a hazard to humans, install a protective cover.

If the moving portion of the product will pose a hazard to humans or will damage machinery or equipment, provide a construction that prevents direct contact with those areas.

4. Be certain that the secured portions will not loosen.

Be certain to adopt a reliable connecting method if the rotary actuator is used very frequently or if it is used in a location that is exposed to a large amount of vibration.

5. There may be cases in which a speed reduction circuit or a shock absorber is required.

If the driven object moves at high speeds or is heavy, it will be unfeasible for only the rotary actuator's cushion to absorb the shock. Therefore, provide a speed-reduction circuit to reduce the rotary actuator's speed before the thrust is applied to the cushion, or an external shock absorber to dampen the shock. If these countermeasures are taken, make sure to take the rigidity of the mechanical equipment into consideration.

6. Consider the possibility of a reduction in the circuit air pressure caused by a power failure.

When an actuator is used as clamping mechanism, there is a danger of workpiece dropping if there is a decrease in clamping force, due to a drop in circuit pressure caused by a power failure. Therefore, safety equipment should be installed to prevent damage to machinery and bodily injury.

7. Consider the possibility of power source related malfunctions that could occur.

For the equipment that rely on power sources such as compressed air, electricity, or hydraulic pressure, adopt a countermeasure to prevent the equipment from causing a hazard to humans or damage to the equipment in the event of malfunction.

8. If a speed controller is provided in the exhaust restrictor, implement a safety design taking the residual pressure into consideration.

If air pressure is applied to the air supply side without residual pressure in the exhaust side, the rotary actuator will operate at abnormally high speed, which could pose a hazard to humans and can damage the machinery and equipment.

9. Consider the behavior of the rotary actuator in the event of an emergency stop.

Devise a safe system so that if a person engages the emergency stop, or if a safety device is tripped during a system malfunction such as a power failure, the movement of the rotary actuator will not cause a hazard to humans or damage the equipment.

10. Consider the action of the rotary actuator when restarting after an emergency stop.

Devise a safe design so that the restarting of the rotary actuator will not pose a hazard to humans or damage the equipment. Install manually controlled equipment for safety when the actuator has to be reset to the starting position.

11. Do not use the product as a shock absorber.

If an abnormal pressure or air leakage occurs, the rotary actuator's speed reduction capability could become severely affected, which could pose a hazard to humans and damage the machinery and equipment.

12. Select a speed within the product's allowable energy value.

If the product's kinetic energy of the load exceeds the allowable value, it could damage the product, and cause a hazard to humans and damage the machinery and equipment.

13. Provide a shock absorber if the kinetic energy that is applied to the product exceeds the allowable value.

If the product's kinetic energy exceeds the allowable value, it could damage the product, and cause a hazard to humans and damage the machinery or equipment.

14. Do not stop or hold the product at midpoint by keeping air pressure in the product.

For a product lacking an external stopping mechanism, if the directional control valve is closed to keep the air pressure in the product, in an attempt to stop the product at midpoint, it might not be possible to maintain that stopped position due to an air leakage. As a result, it could pose a hazard to humans and cause damage to machinery and/or equipment.

15. Give consideration to the decline in strength caused by changes of the shaft type.

Some shaft types, such as simple specials, may have shapes and dimensions that result in decreased strength when compared with standard models. Consider this carefully when using.

16. Do not use two or more rotary actuators with the aim of synchronized movement.

One of the actuators may bear the load of operation, making synchronized movement impossible, and possibly leading to deformation of the equipment.

17. Do not use in a location where adverse effect could be occurred by the oozing of the lubricant to the exterior.

The lubricant coating the interior of the product may leak to the outside of the product from the portion of the connection of the rotary shaft, body cover, etc.

18. Do not disassemble the product or make any modifications, including additional machining.

It may cause human injury and/or an accident.

19. Refer to the Auto Switches Precautions for using with an auto switch.



Rotary Actuators Precautions 2

Be sure to read this before handling.

Design / Selection

⚠ Caution

1. Do not use below the speed adjustment range specified for the product.

If the product is used below the specified speed adjustment range, it could cause the product to stick, slip, or the movement to stop.

2. Do not apply an external torque to the product that exceeds the rated output.

If an external force that exceeds the product's rated output is applied to the product, it could damage the product.

3. The holding torque of the rotating end of the double piston type.

If the internal piston of a double piston product comes in contact with the angle adjustment screen or the cover and stops, the holding torque at the rotating end is one half of the actual output.

4. If it is necessary to provide repeatability of the rotation angle, directly stop the load externally.

Even with a product that is equipped with an angle adjuster, there are times in which the initial rotation angle could change.

5. Do not use under hydraulic pressure.

The product will be damaged if it is used by applying hydraulic pressure.

6. There is a possibility of backlash being generated when stopping the double piston style in the middle with a valve of the closed center type.

7. For the vane type product, if it is necessary to ensure a rotation angle, make sure to use a minimum pressure of 0.3 MPa.

8. Do not use the made-to-order -XC30 at low speeds.

Although fluorine grease is used, it is not designed for low-speed applications.

For information on fluorine grease, refer to the Material Safety Data Sheet (MSDS).

9. Do not use in places where there are many temperature fluctuations. When using in lower temperature applications, use caution so that frost does not occur inside the cylinder or the piston rod.

Operation may be unstable.

10. Adjust the speed control in the environment in which it will be used in.

Speed adjustment may be changed if the environment is different.

Mounting

⚠ Warning

1. Operation manual

Install the product and operate it only after reading the operation manual carefully and understanding its contents. Also, keep the manual in a location where it can be referred to as necessary.

Mounting

⚠ Warning

2. Ensure sufficient space for maintenance activities.

When installing the products, allow access for maintenance.

3. Tighten threads with the proper tightening torque.

When installing the products, follow the listed torque specifications.

4. Before adjusting the angle by supplying air pressure, take appropriate measures to prevent the equipment from rotating unnecessarily.

When an adjustment is performed under air pressure, the equipment could rotate and fall during the adjustment, depending on the mounted placement of the equipment. As a result, it could pose a hazard to humans and damage the machinery and equipment.

5. Do not loosen the angle adjustment screw beyond the allowable adjustment range.

The angle adjustment screw could fall out if it is loosened beyond its allowable adjustment range and cause a hazard to humans and damage to machinery and equipment.

6. Do not place a magnetic object near the product.

The auto switch is a magnetic sensing type. If a magnetic object is placed close to it, the rotary actuator could operate suddenly, which could pose a hazard to humans and damage the machinery and equipment.

7. Do not perform additional machining to the product.

Additional machining to the product can result in insufficient strength and cause damage to the product. This can lead to possible human injury and damage to the surrounding equipment.

8. Do not enlarge the fixed throttle by modifying the pipe connectors.

If the hole diameter is enlarged, the product's rotation speed will increase, causing the shock force to increase and damage to the product. As a result, it could pose a hazard to humans and damage the machinery and equipment.

9. If shaft couplings are used, use those with angular freedom.

If shaft couplings that lack angular freedom are used, they could scrape due to eccentricity, leading to equipment malfunction and product damage. As a result, it could pose a hazard to humans and damage the machinery and equipment.

10. Do not apply to the shaft a load that exceeds the values given in a catalog.

If a load that exceeds the allowable value is applied to the product, it could lead to equipment malfunction, a hazard to humans, and damage to the machinery and equipment. Provided that a dynamic load is not generated, a load that is within the allowable radial/thrust load can be applied. However, applications in which the load is applied directly to the shaft should be avoided wherever possible. The methods such as those described below are recommended to prevent the load from being applied directly to the shaft in order to ensure a proper operating condition.

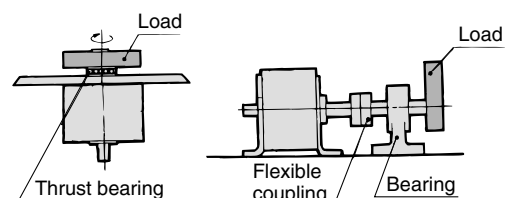

CRB2

CRBU2

CRB1

MSU

CRJ

CRA1

CRQ2

MSQ

MSZ

CRQ2X

MSQX

MRQ

D-□



Rotary Actuators Precautions 3

Be sure to read this before handling.

Mounting

Warning

11. Place an external stopper in a position that is away from the rotating shaft.

If the stopper is placed near the rotating shaft, the torque that is generated by the product itself will cause the reaction force which is directed to the stopper to be redirected and applied to the rotating shaft. This will lead to the breakage of the rotating shaft and bearing. As a result, it could pose a hazard to humans and damage the machinery and equipment.

Precautions when Using External Stoppers

- Be sure to install external stoppers in the proper places. Installation in the wrong place can result in equipment breakage, which could damage other equipment or cause human injury.

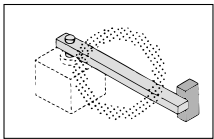

Install the stopper at a sufficient distance from the rotating shaft.

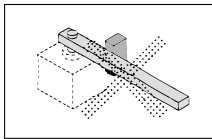

The external stopper becomes a fulcrum, resulting in the load's inertia force being applied to the shaft as a bending moment.

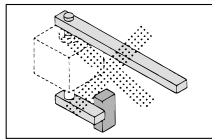

If an external stopper is installed on the shaft side which is opposite of the load, the inertia force generated by the load is applied directly to the shaft.

- Install external stoppers within the range of the rotating shaft angle. Installing an external stopper at the maximum rotation angle may result in inability to fully absorb the kinetic energy generated, and damage to equipment may occur. When using external stoppers at rotation angles of 90°, 180°, or 270°, use products with rotation angles of 100°, 190°, or 280° respectively.

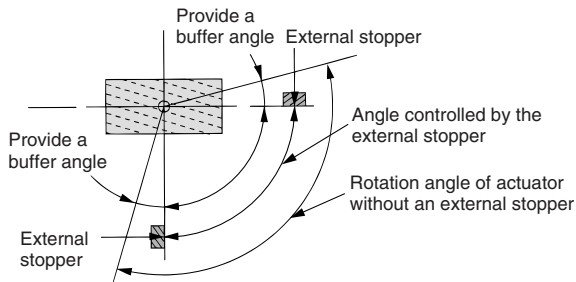

Backlash of the Single Rack Pinion Type CRA1 Series

There is a backlash of within 1° at the rotation end of the CRA1 series. It is necessary to decide the position of the external stopper when precise rotation is required.

Precautions when Converting Rotational Motion to Linear Motion

When using a link mechanism, etc., to convert rotational motion to linear motion, and determining the operation end using the stopper on the linear motion end (see below), a small value for θ at the operation end may result in the torque of the rotary actuator causing excessive radial load to act on the output axle, and equipment breakage may occur.

Install a stopper on the rotational motion side, or increase the value of θ at the operation end, to make sure the load generated does not exceed the allowable value for the product.

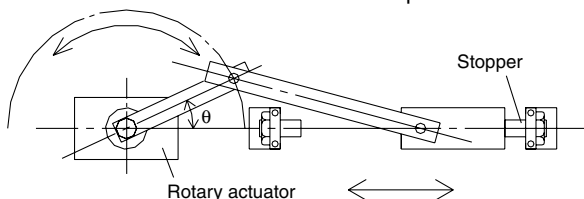

12. Do not use springs, etc., to add force in the rotational movement direction.

When rotational force from an external spring, etc., acts and generates negative pressure on the product's interior, breakage of the internal seal or acceleration of abrasion may occur.

Caution

1. Observe the specified torque to secure the block of the angle adjustment unit.

If it is secured with a torque that is lower than the specified torque, the block could become loosened during use, causing the angle to exceed the set angle.

2. Do not use organic solvent to wipe the area of the name plate that shows the model.

It will erase what is indicated on the name plate.

3. Do not hit the rotating shaft by securing the body or hit the body by securing the rotating shaft.

These actions could cause the shaft to bend or damage the bearing. When a load must be coupled to the rotating shaft, secure the rotating shaft.

4. Do not place your foot directly on the shaft or on the equipment that is coupled to the shaft.

Placing one's weight directly onto the rotating shaft could cause the rotating shaft or the bearing to become damaged.

5. If a product is equipped with an angle adjustment function, use it within the specified adjustment range.

If the product is used outside the specified adjustment range, it could lead to equipment malfunction or product damage. Refer to the product specifications for details on the adjustment range of the products.

Piping

Caution

1. Refer to the Fittings and Tubing Precautions (Best Pneumatics No. 6) for handling one-touch fittings.

2. Preparation before piping

Before piping is connected, it should be thoroughly blown out with air (flushing) or washed to remove chips, cutting oil and other debris from inside the pipe.

3. Wrapping of pipe tape

When screwing piping or fittings into ports, ensure that chips from the pipe threads or sealing material do not enter the piping. Also, if pipe tape is used, leave 1.5 to 2 thread ridges exposed at the end of the threads.

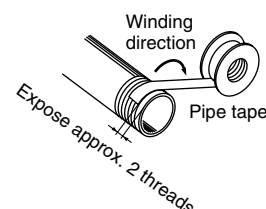



Rotary Actuators Precautions 4

Be sure to read this before handling.

Speed and Cushion Adjustment

⚠ Warning

1. To make a speed adjustment, gradually adjust starting from the low speed end.

If the speed adjustment is performed from the high speed end, it could damage the product. As a result, it could pose a hazard to humans and damage the machinery and equipment.

2. The cushion needle is not adjusted at the time of shipment. Therefore, an adjustment must be made in accordance with the operating speed and the moment of inertia of the load.

The absorption of kinetic energy by the bumper is regulated by the adjustment of the needle. An improper adjustment could lead to damage of the equipment and the product. As a result, it could pose a hazard to humans and damage the machinery and equipment.

3. Do not operate with the cushion needle in a fully closed condition.

This could tear the seal, which could pose a hazard to humans and damage the machinery and equipment.

4. Do not apply an excessive force to loosen the cushion needle.

The needle itself is provided with a pull stop. However, the pullstop could be damaged if the needle is loosened through the application of excessive force. As a result, it could pose a hazard to humans and damage the machinery and equipment.

5. For products with shock absorbers, when the shock absorber stops motion before reaching the stroke end using a stopper mechanism with the objective of shortening takt time, be sure the shock absorber is stopped in a position where it has adequately absorbed the kinetic energy.

Failure to do so can result in damage to equipment.

Lubrication

⚠ Warning

1. This product should be used without lubrication. Although it will operate even if it is lubricated, it could lead to sticking or slipping.

Air Supply

⚠ Warning

1. Type of fluids

Please consult with SMC when using the product in applications other than compressed air.

2. When there is a large amount of drainage.

Compressed air containing a large amount of drainage can cause malfunction of pneumatic equipment. An air dryer or water separator should be installed upstream from filters.

3. Drain flushing

If condensation in the drain bowl is not emptied on a regular basis, the bowl will overflow and allow the condensation to enter the compressed air lines. It causes malfunction of pneumatic equipment.

Air Supply

⚠ Warning

If the drain bowl is difficult to check and remove, installation of a drain bowl with an auto drain option is recommended. For compressed air quality, refer to Best Pneumatics No. 5.

4. Use clean air.

Do not use compressed air that contains chemicals, synthetic oils including organic solvents, salt or corrosive gases, etc., as it can cause damage or malfunction.

⚠ Caution

1. When extremely dry air is used as the fluid, degradation of the lubrication properties inside the equipment may occur, resulting in reduced reliability (or reduced service life) of the equipment. Please consult with SMC.

2. Install an air filter.

Install an air filter upstream near the valve. Select an air filter with a filtration size of 5 μm or smaller.

3. Take measures to ensure air quality, such as by installing an aftercooler, air dryer, or water separator.

Compressed air that contains a large amount of drainage can cause malfunction of pneumatic equipment such as rotary actuators. Therefore, take appropriate measures to ensure air quality, such as by providing an aftercooler, air dryer, or water separator.

4. Ensure that the fluid and ambient temperature are within the specified range.

If the fluid temperature is 5°C or less, the moisture in the circuit could freeze, causing damage to the seals and equipment malfunction. Therefore, take appropriate measures to prevent freezing.

For compressed air quality, refer to Best Pneumatics No. 5.

Operating Environment

⚠ Warning

1. Do not use in an atmosphere having corrosive gases, chemicals, sea water, water, water steam, or where there is direct contact with any of these.

Refer to the construction for information on the rotary actuators material.

2. Do not expose the product to direct sunlight for an extended period of time.

3. Do not use in a place subject to heavy vibration and/or shock.

4. Do not mount the product in locations where it is exposed to radiant heat.

5. Do not use in dusty locations or where water or oil, etc., splash on the equipment.

CRB2

CRBU2

CRB1

MSU

CRJ

CRA1

CRQ2

MSQ

MSZ

CRQ2X
MSQX

MRQ

D-□



Rotary Actuators Precautions 5

Be sure to read this before handling.

Maintenance

Warning

1. Perform maintenance inspection according to the procedures indicated in the operation manual.

If handled improperly, malfunction and damage of machinery or equipment may occur.

2. Maintenance work

If handled improperly, compressed air can be dangerous. Assembly, handling, repair and element replacement of pneumatic systems should be performed by a knowledgeable and experienced person.

3. Drain flushing

Remove drainage from air filters regularly.

4. Removal of equipment, and supply/exhaust of compressed air

When components are removed, first confirm that measures are in place to prevent workpieces from dropping, run-away equipment, etc. Then, cut off the supply pressure and electric power, and exhaust all compressed air from the system using the residual pressure release function.

When machinery is restarted, proceed with caution after confirming that appropriate measures are in place to prevent cylinders from sudden movement.

Caution

1. For lubrication, use the designated grease for each specific product.

The use of a non-designated lubricant could damage the seals.



Rotary Actuators Precautions 6

Be sure to read this before handling.

For Air-hydro Type

Please read this page along with the Rotary Actuators Precautions.

Design

⚠ Warning

1. Do not use the product near flames, or in equipment or machinery that exceeds an ambient temperatures of 60°C.

There is a danger of causing a fire because the air-hydro type uses a flammable hydraulic fluid.

Refer to the Material Safety Data Sheet (MSDS) of the hydraulic fluid when supplying the fluid.

2. Do not use the product in a clean room.

⚠ Caution

1. Do not use in an environment, equipment, or machine that is not compatible with oil mist.

The air-hydro type generates an oil mist during operation which may affect the environment.

2. Be certain to install an exhaust cleaner on the directional control valve for the air-hydro type.

A very small amount of hydraulic fluid is discharged from the exhaust port of a directional control valve, which may contaminate the surrounding area.

3. Install the air-hydro type in locations where it can be serviced easily.

Since the air-hydro type requires maintenance, such as refilling of hydraulic fluid and bleeding of air, ensure sufficient space for these activities.

Selection

⚠ Caution

1. Select an air-hydro type in combination with an air-hydro unit.

Since good operation of an air-hydro type depends on its combination with an air-hydro unit, carefully select an appropriate air-hydro unit.

Piping

⚠ Warning

1. For air-hydro type piping, use self-aligning fittings.

Do not use one-touch fittings in the piping for an air-hydro type, because oil leakage may occur.

2. For air-hydro type piping, use hard nylon tubing or copper piping.

As in the case of hydraulic circuits, surge pressures greater than the operating pressure may occur in an air-hydro type piping, making it necessary to use safer piping materials.

Lubrication

⚠ Warning

1. Completely discharge the compressed air in the system before filling the air-hydro unit with hydraulic oil.

When supplying hydraulic fluid to the air-hydro unit, first confirm that safety measures are implemented to prevent dropping of objects and the release of clamped objects, etc. Then, shut off the air supply and the equipment's electric power and exhaust the compressed air in the system.

If the air-hydro unit's supply port is opened with compressed air still remaining in the system, there is a danger of hydraulic fluid being blown out.

Refer to the Material Safety Data Sheet (MSDS) of the hydraulic fluid when supplying the fluid.

2. Use petroleum hydraulic fluid which can be used as turbine oil.

If non-flammable hydraulic fluid is used, it may cause problems.

Suitable viscosity is in the range of approximately 40 to 100 mm²/s in operating temperature.

The suitable operating temperature for ISO VG32 is the range of 15 to 35°C. If the operating temperature range is beyond ISO VG32, select ISO VG46 (suitable for 25 to 45°C range).

ISO VG32 Turbine Oil

(Example)

[With no additive]

Idemitsu Kosan Co., Ltd. : Turbine Oil P-32

Nippon Oil Corporation : Turbine Oil 32

: Mitsubishi Turbine Oil 32

Cosmo Oil Co., Ltd. : Cosmo Turbine 32

[With additive]

Idemitsu Kosan Co., Ltd. : Daphne Turbine Oil 32

Nippon Oil Corporation : FBK Turbine 32

: Diamond Turbine Oil 32

Cosmo Oil Co., Ltd. : Turbine Super 32

Maintenance

⚠ Caution

1. Bleed air from the air-hydro type on a regular basis.

Since air may accumulate inside the air-hydro type, bleed air from it, for example before starting work. Bleed air from a bleeder valve provided on the air-hydro type or the piping.

2. Verify the oil level of the air-hydro system on a regular basis.

Since a very small amount of hydraulic fluid is discharged from the air-hydro type and the air-hydro unit circuit, the fluid will gradually decrease. Therefore, check the fluid regularly and refill as necessary.

The oil level can be checked with a level gauge in the air-hydro converter.

CRB2

CRBU2

CRB1

MSU

CRJ

CRA1

CRQ2

MSQ

MSZ

CRQ2X

MSQX

MRQ

D-□



Auto Switches Precautions 1

Be sure to read this before handling.

Design / Selection

Warning

1. Confirm the specifications.

Read the specifications carefully and use this product appropriately. The product may be damaged or malfunction if it is used outside the specification range for current load, voltage, temperature or impact.

We do not guarantee against any damage if the product is used outside of the specification range.

2. Cautions for use in an interlock circuit

When an auto switch is used for an interlock signal requiring high reliability, devise a double interlock system to avoid trouble by providing a mechanical protection function, or by also using another switch (sensor) together with the auto switch. Also, perform periodic maintenance and confirm proper operation.

3. Do not make any modifications (including exchanging the printed circuit boards) to the product.

It may cause human injuries and accidents.

Caution

1. Pay attention to the length of time that a switch is ON at an intermediate stroke position.

When an auto switch is placed at an intermediate position of the stroke and a load is driven at the time the piston passes, the auto switch will operate, but if the speed is too great the operating time will be shortened and the load may not operate properly. The maximum detectable piston speed is:

$$V \text{ (mm/s)} = \frac{\text{Auto switch operating range (mm)}}{\text{Time load applied (ms)}} \times 1000$$

In cases of high piston speed, the use of an auto switch (D-F5NNTL, F7NNTL, G5NNTL, M5NNTL, M5PNTL) with a built-in OFF delay timer (≈ 200 ms) makes it possible to extend the load operating time.

The wide-range detection type D-G5NBL (operating range 35 to 50 mm) may also be useful, depending on the application. Please consult with SMC for other models.

Caution

2. Keep wiring as short as possible.

<Reed>

As the length of the wiring to a load gets longer, the rush current at switching ON becomes greater, and this may shorten the product's life. (The switch will stay ON all the time.)

1) Use a contact protection box when the wire length is 5 m or longer.

2) Even if an auto switch has a built-in contact protection circuit, when the wiring is more than 30 m long, it is not able to adequately absorb the rush current and its life may be reduced. It is again necessary to connect a contact protection box in order to extend its life. Please consult with SMC in this case.

<Solid state>

3) Although wire length should not affect switch function, use a wire 100 m or shorter.

If the wiring is longer it will likely increase noise although the length is less than 100 m.

When the wire length is long, we recommend the ferrite core is attached to the both ends of the cable to prevent excess noise.

A contact protection box is not necessary for solid state switches due to the nature of this product construction.

3. Do not use a load that generates surge voltage. If a surge voltage is generated, the discharge occurs at the contact, possibly resulting in the shortening of product life.

If driving a load such as a relay that generates a surge voltage,

<Reed>

Use an auto switch with built-in contact protection circuit or use a contact protection box.

<Solid state>

Use a built-in surge absorbing element type device.

4. Take precautions when multiple cylinders/actuators are used close together.

When multiple auto switch cylinders/actuators are used in close proximity, magnetic field interference may cause the auto switches to malfunction. Maintain a minimum cylinder separation of 40 mm. (When the allowable interval is specified for each cylinder series, use the indicated value.)

The auto switches may malfunction due to the interference from the magnetic fields.

Use of a magnetic screen plate (MU-S025) or commercially available magnetic screen tape can reduce the interference of magnetic force.



Auto Switches Precautions 2

Be sure to read this before handling.

Design / Selection

⚠ Caution

5. Pay attention to the internal voltage drop of the auto switch.

<Reed>

1) Auto switch with an indicator light (Except D-A56, A76H, A96, A96V, C76, E76A, Z76)

- If auto switches are connected in series as shown below, take note that there will be a large voltage drop because of internal resistance in the light emitting diodes. (Refer to the internal voltage drop in the auto switch specifications.) [The voltage drop will be “n” times larger when “n” auto switches are connected.]

Even though an auto switch operates normally, the load may not operate.

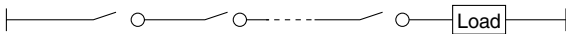

- In the same way, when operating under a specified voltage, although an auto switch may operate normally, the load may not operate. Therefore, the formula below should be satisfied after confirming the minimum operating voltage of the load.

$$\text{Supply voltage} - \text{Internal voltage drop of auto switch} > \text{Minimum operating voltage of load}$$

2) If the internal resistance of a light emitting diode causes a problem, select an auto switch without an indicator light (D-A6□, A80, A80H, A90, A90V, C80, R80, 90, E80A, Z80).

<Solid state/2-wire type>

3) Generally, the internal voltage drop will be greater with a 2-wire solid state auto switch than with a reed auto switch. Take the same precautions as in 1). Also, take note that a 12 VDC relay is not applicable.

6. Pay attention to leakage current.

<Solid state/2-wire type>

Current (leakage current) flows to the load to operate the internal circuit even when in the OFF state.

$$\text{Operating current of load (OFF condition)} > \text{Leakage current}$$

If the criteria given in the above formula are not met, it will not reset correctly (stays ON). Use a 3-wire switch if this specification will not be satisfied.

Moreover, leakage current flow to the load will be “n” times larger when “n” auto switches are connected in parallel.

7. Ensure sufficient clearance for maintenance activities.

When designing an application, be certain to allow sufficient clearance for maintenance.

8. When multiple auto switches are required.

“n” indicates the number of auto switches which can be physically mounted on the cylinders/actuators. Detection intervals depends on the auto switch mounting structure and set position, therefore some required interval and set positions may not be available.

9. Limitations of detectable positioning

When using certain mounting brackets, the surface and position where an auto switch can be mounted maybe restricted due to physical interference. For example, when using some bracket types the auto switch cannot be surface mounted at the bottom side of foot bracket, etc.

Select the set position of the auto switch so that it does not interfere with the mounting bracket of the cylinders/actuators (such as trunnion or reinforcement ring).

10. Use the cylinder and auto switch in proper combination.

The auto switch is pre-adjusted to activate properly for an auto-switch-capable SMC cylinder/actuator.

If the auto switch is mounted improperly, used for another brand of cylinders/actuators or used after the alternation of the machine installation, the auto switch may not activate properly.

Mounting / Adjustment

⚠ Caution

1. Do not drop or bump.

Do not drop, bump or apply excessive impacts (300 m/s² or more for reed auto switches and 1000 m/s² or more for solid state auto switches) while handling. Although the body of the auto switch may not be damaged, the inside of the auto switch could be damaged and cause malfunction.

2. Observe the proper tightening torque for mounting an auto switch.

When an auto switch is tightened beyond the range of tightening torque, auto switch mounting screws, auto switch mounting brackets or auto switch may be damaged.

On the other hand, tightening below the range of tightening torque may allow the auto switch to slip out of position.

3. Do not carry a cylinder by the auto switch lead wires.

Never carry a cylinder by its lead wires. This may not only cause broken lead wires, but it may cause internal elements of the auto switch to be damaged by the stress.

4. Fix the auto switch with appropriate screw installed on the switch body. If using other screws, auto switch may be damaged.

CRB2

CRBU2

CRB1

MSU

CRJ

CRA1

CRQ2

MSQ

MSZ

CRQ2X

MSQX

MRQ

D-□



Auto Switches Precautions 3

Be sure to read this before handling.

Wiring

⚠ Caution

1. Confirm proper insulation of wiring.

Be certain that there is no faulty wiring insulation (contact with other circuits, ground fault, improper insulation between terminals, etc.). Damage may occur due to excess current flow into a switch.

2. Do not wire with power lines or high voltage lines.

Wire separately from power lines or high voltage lines, avoiding parallel wiring or wiring in the same conduit with these lines. Control circuits containing auto switches may malfunction due to noise from these other lines.

3. Avoid repeatedly bending or stretching lead wires.

Broken lead wires will result from repeatedly applying bending stress or stretching force to the lead wires.

Stress and tensile force applied to the connection between the cable and auto switch increases the possibility of disconnection.

Fix the cable in the middle so that it is not movable in the area where it connects with the auto switch.

4. Be certain to connect the load before power is applied.

<2-wire type>

If the power is turned ON when an auto switch is not connected to a load, the auto switch will be instantly damaged because of excess current (short circuit).

It is the same as when the 2-wire brown lead wire (+, output) is directly connected to the (+) power supply terminal.

5. Do not allow short-circuit of loads.

<Reed>

If the power is turned ON with a load in a short circuited condition, the auto switch will be instantly damaged because of excess current flow into the switch.

<Solid state>

All models of D-J51, G5NB and PNP output type auto switches do not have built-in short circuit protection circuits.

If a load is short circuited, the auto switch will be instantly damaged as in the case of reed auto switches.

Take special care to avoid reverse wiring with the brown power supply line and the black output line on 3-wire type auto switches.

6. Avoid incorrect wiring.

<Reed>

A 24 VDC auto switch with indicator light has polarity. The brown lead wire or terminal No. 1 is (+), and the blue lead wire or terminal No. 2 is (-).

[For D-97, (+) is on the no-displayed side, (-) is on the black line side.]

1) If connections are reversed, an auto switch will operate, however, the light emitting diode will not light up.

Also, take note that a current greater than that specified will damage a light emitting diode and it will no longer operate.

Applicable model:

D-A73, A73H, A73C, C73, C73C, E73A, Z73

D-R73, R73C, 97, 93A, A93, A93V

D-A33, A34, A33A, A34A, A44, A44A

D-A53, A54, B53, B54

2) When using a 2-color indicator type auto switch (D-A79W, A59W and B59W), the auto switch will constantly remain ON if the connections are reversed.

<Solid state>

1) If connections are reversed on a 2-wire type auto switch, the auto switch will not be damaged if protected by a protection circuit, but the auto switch will always stay in an ON state. However, it is still necessary to avoid reversed connections, since the auto switch could be damaged by a load short circuit in this condition.

2) If connections are reversed (power supply line + and power supply line -) on a 3-wire type auto switch, the auto switch will be protected by a protection circuit. However, if the power supply line (+) is connected to the blue wire and the power supply line (-) is connected to the black wire, the auto switch will be damaged.

7. When the cable sheath is stripped, confirm the stripping direction. The insulator may be split or damaged depending on the direction. (D-M9□ only)

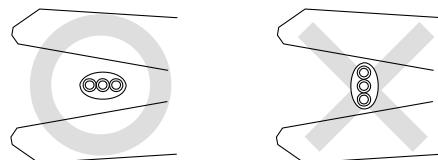

Recommended Tool

Description	Model
Wire stripper	D-M9N-SWY

* Stripper for a round cable (ø2.0) can be used for a 2-wire type cable.

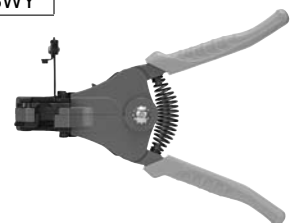



Auto Switches Precautions 4

Be sure to read this before handling.

Operating Environment

⚠ Warning

1. Never use in an atmosphere of explosive gases.

The structure of auto switches is not intended to prevent explosion. Never use in an atmosphere with an explosive gas since this may cause a serious explosion. Please contact SMC concerning ATEX compliant products.

⚠ Caution

1. Do not use in an area where a magnetic field is generated.

Auto switches will malfunction or magnets inside cylinders/actuators will become demagnetized. (Please consult with SMC if a magnetic field resistant auto switch can be used.)

2. Do not use in an environment where the auto switch will be continually exposed to water.

Although auto switches satisfy IEC standard IP67 construction (JIS C 0920: waterproof construction) except some models (D-A3□, A44□, G39□, K39□, RNK, RPK) do not use auto switches in applications where continually exposed to water splash or spray. Poor insulation or swelling of the potting resin inside auto switches may cause malfunction.

3. Do not use in an environment with oil or chemicals.

Please consult with SMC if auto switches will be used in an environment with coolant, cleaning solvent, various oils or chemicals. If auto switches are used under these conditions for even a short time, they may be adversely affected by improper insulation, malfunction due to swelling of the potting resin, or hardening of the lead wires.

4. Do not use in an environment with temperature cycles.

Please consult with SMC if auto switches are used where there are temperature cycles other than normal temperature changes, as there may be adverse effects inside the auto switches.

5. Do not use in an environment where there is excessive impact shock.

<Reed>

When excessive impact (300 m/s² or more) is applied to a reed auto switch during operation, the contact point will malfunction and generate or cut off a signal momentarily (1 ms or less). Please consult with SMC if a solid state auto switch can be used according to the environment.

6. Do not use in an area where surges are generated.

<Solid state>

When there are units (solenoid type lifter, high frequency induction furnace, motor, radio equipment etc.) which generate a large amount of surge in the area around cylinders/actuators with solid state auto switches, this may cause deterioration or damage to the auto switch's internal circuit elements. Avoid sources of surge generation and disorganized lines.

⚠ Caution

7. Avoid accumulation of iron waste or close contact with magnetic substances.

When a large amount of iron waste such as machining chips or spatter is accumulated, or a magnetic substance (something attracted by a magnet) is brought into close proximity with a cylinder with auto switches, or an actuator, it may cause the auto switch to malfunction due to a loss of the magnetic force inside the cylinder/actuator.

8. Please contact SMC concerning water resistance, elasticity of lead wires, usage at welding sites, etc.

9. Do not use in direct sunlight.

10. Do not mount the product in locations where it is exposed to radiant heat.

Maintenance

⚠ Warning

1. Removal of equipment, and supply/exhaust of compressed air

Before any machinery or equipment is removed, first ensure that the appropriate measures are in place to prevent the fall or erratic movement of driven objects and equipment, then cut off the electric power and reduce the pressure in the system to zero. Only then should you proceed with the removal of any machinery and equipment.

When machinery is restarted, proceed with caution after confirming that appropriate measures are in place to prevent actuators from moving suddenly.

⚠ Caution

1. Perform the following maintenance periodically in order to prevent possible danger due to unexpected auto switch malfunction.

1) Secure and tighten auto switch mounting screws.

If screws become loose or the mounting position is dislocated, retighten them after readjusting the mounting position.

2) Confirm that there is no damage to lead wires.

To prevent faulty insulation, replace auto switches or repair lead wires, etc., if damage is discovered.

3) Confirm the lighting of the green light on the 2-color indicator type auto switch.

Confirm that the green LED is on when stopped at the established position. If the red LED is on, the mounting position is not appropriate. Readjust the mounting position until the green LED lights up.

CRB2

CRBU2

CRB1

MSU

CRJ

CRA1

CRQ2

MSQ

MSZ

CRQ2X
MSQX

MRQ

D-□





Safety Instructions

These safety instructions are intended to prevent hazardous situations and/or equipment damage. These instructions indicate the level of potential hazard with the labels of “**Caution**,” “**Warning**” or “**Danger**.” They are all important notes for safety and must be followed in addition to International Standards (ISO/IEC), Japan Industrial Standards (JIS)*1) and other safety regulations*2).

- * 1) ISO 4414: Pneumatic fluid power – General rules relating to systems.
- ISO 4413: Hydraulic fluid power – General rules relating to systems.
- IEC 60204-1: Safety of machinery – Electrical equipment of machines. (Part 1: General requirements)
- ISO 10218-1992: Manipulating industrial robots -Safety.
- JIS B 8370: General rules for pneumatic equipment.
- JIS B 8361: General rules for hydraulic equipment.
- JIS B 9960-1: Safety of machinery – Electrical equipment of machines. (Part 1: General requirements)
- JIS B 8433-1993: Manipulating industrial robots - Safety.
- etc.
- * 2) Labor Safety and Sanitation Law, etc.

 **Caution:** Operator error could result in injury or equipment damage.

 **Warning:** Operator error could result in serious injury or loss of life.

 **Danger :** In extreme conditions, there is a possibility of serious injury or loss of life.

Warning

1. The compatibility of the product is the responsibility of the person who designs the equipment or decides its specifications.

Since the product specified here is used under various operating conditions, its compatibility with specific equipment must be decided by the person who designs the equipment or decides its specifications based on necessary analysis and test results. The expected performance and safety assurance of the equipment will be the responsibility of the person who has determined its compatibility with the product. This person should also continuously review all specifications of the product referring to its latest catalog information, with a view to giving due consideration to any possibility of equipment failure when configuring the equipment.

2. Only personnel with appropriate training should operate machinery and equipment.

The product specified here may become unsafe if handled incorrectly. The assembly, operation and maintenance of machines or equipment including our products must be performed by an operator who is appropriately trained and experienced.

3. Do not service or attempt to remove product and machinery/equipment until safety is confirmed.

1. The inspection and maintenance of machinery/equipment should only be performed after measures to prevent falling or runaway of the driven objects have been confirmed.
2. When the product is to be removed, confirm that the safety measures as mentioned above are implemented and the power from any appropriate source is cut, and read and understand the specific product precautions of all relevant products carefully.
3. Before machinery/equipment is restarted, take measures to prevent unexpected operation and malfunction.

4. Contact SMC beforehand and take special consideration of safety measures if the product is to be used in any of the following conditions.

1. Conditions and environments outside of the given specifications, or use outdoors or in a place exposed to direct sunlight.
2. Installation on equipment in conjunction with atomic energy, railways, air navigation, space, shipping, vehicles, military, medical treatment, combustion and recreation, or equipment in contact with food and beverages, emergency stop circuits, clutch and brake circuits in press applications, safety equipment or other applications unsuitable for the standard specifications described in the product catalog.
3. An application which could have negative effects on people, property, or animals requiring special safety analysis.
4. Use in an interlock circuit, which requires the provision of double interlock for possible failure by using a mechanical protective function, and periodical checks to confirm proper operation.



Safety Instructions

Caution

The product is provided for use in manufacturing industries.

The product herein described is basically provided for peaceful use in manufacturing industries.

If considering using the product in other industries, consult SMC beforehand and exchange specifications or a contract if necessary. If anything is unclear, contact your nearest sales branch.

Limited Warranty and Disclaimer/Compliance Requirements

The product used is subject to the following “Limited Warranty and Disclaimer” and “Compliance Requirements”. Read and accept them before using the product.

Limited Warranty and Disclaimer

1. The warranty period of the product is 1 year in service or 1.5 years after the product is delivered.*3)

Also, the product may have specified durability, running distance or replacement parts. Please consult your nearest sales branch.

2. For any failure or damage reported within the warranty period which is clearly our responsibility, a replacement product or necessary parts will be provided.

This limited warranty applies only to our product independently, and not to any other damage incurred due to the failure of the product.

3. Prior to using SMC products, please read and understand the warranty terms and disclaimers noted in the specified catalog for the particular products.

* 3) Vacuum pads are excluded from this 1 year warranty.

A vacuum pad is a consumable part, so it is warranted for a year after it is delivered.

Also, even within the warranty period, the wear of a product due to the use of the vacuum pad or failure due to the deterioration of rubber material are not covered by the limited warranty.

Compliance Requirements

When the product is exported, strictly follow the laws required by the Ministry of Economy, Trade and Industry (Foreign Exchange and Foreign Trade Control Law).