

Clamp Cylinder with Lock

CLK2 Series

Maintains a clamped or unclamped state when air supply pressure drops or residual pressure is released.

Total length reduced by 2 mm

Body is shortened while maintaining the mounting interchangeability with the current series (CLK1).

With a cover configuration eliminating protruding valves

Improved workability

- ▶ Magnetic field resistant auto switches are mountable.
- ▶ With air cushion (head end)
- ▶ $\varnothing 32$ to $\varnothing 63$ introduced to series
- ▶ 2 series, 4 sizes and 3 clevis widths have been standardized.

Widely applicable to different types of equipment

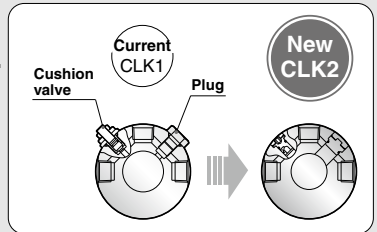

Series		Bore size (mm)	Clevis width (mm)	Stroke (mm)
Built-in standard magnet type	CLK2G□ series	32	12	50
		40	12.5, 16.5	75
		50, 63	12.5, 16.5, 19.5	100
Built-in strong magnet type	CLK2P□ series	40	12.5, 16.5	125
		50, 63	12.5, 16.5, 19.5	150



Clamp Cylinder with Lock *CLK2 Series*

- Can be locked at any position within the entire stroke.
Locking is possible at any desired position.
Able to easily accommodate changes in work piece thickness.

Retraction locking



- A selection of retraction locking and extension locking is possible.

<Example>

Holding a clamped state

Prevents work piece slippage and dropping due to work piece weight.

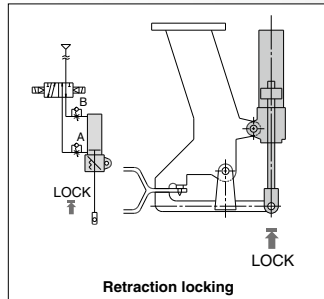

Holding an unclamped state

Prevents dislocation of current position due to weight of clamp arm.

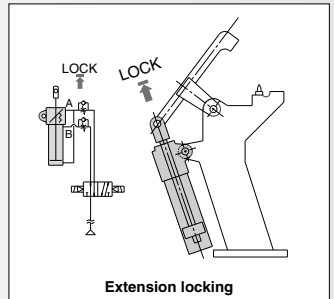

- Compact lock mechanism minimizes extension of length dimension.

CLK2 series clamp cylinder with lock

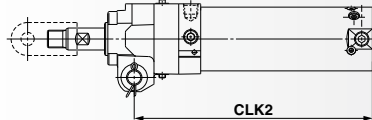

CK1 series clamp cylinder (without lock)

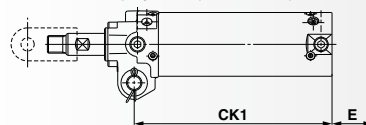

Extended Dimension (mm)

Bore size	E
ø40	34
ø50	38.5
ø63	42

Operating Principle

● Retraction locking

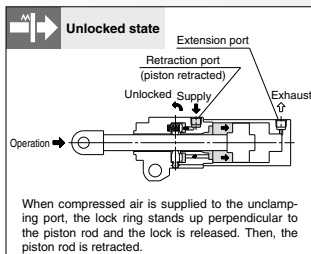
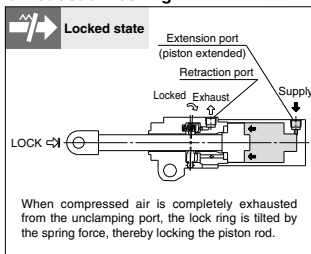

● Extension locking

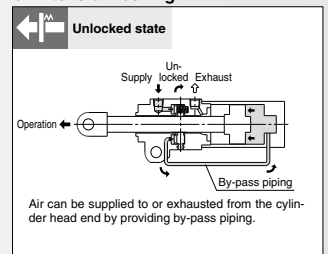

Piping is not required for unlocking.

Since a solenoid valve dedicated for unlocking is not required, reduction of initial costs and replacement of current equipment can be easily accomplished.

Clamp cylinder with lock

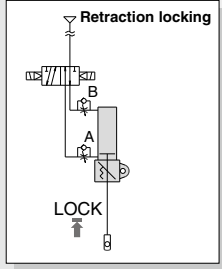

Cylinder with lock (CN□ series)

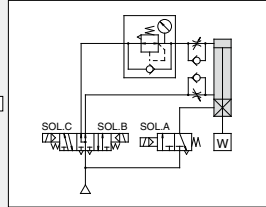

* The symbol for the cylinder with lock in the pneumatic circuit uses SMC original symbol.

Extension locking
LOCK
↑



Able to maintain an unlocked state

Assembly and maintenance simplified

The auto switch mounting and the piping position are available in three-way directions and any desired position.

Piping is possible in three-way directions regardless of the auto switch mounting position.

Note) For port/bypass mounting positions, refer to pages 465 and 472.

Auto switch

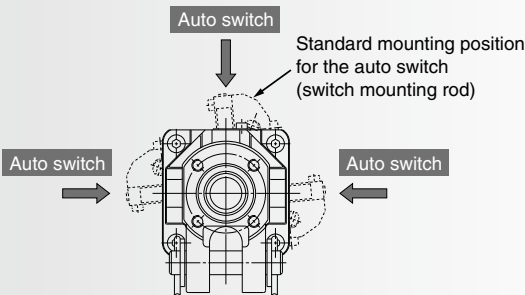

Piping port

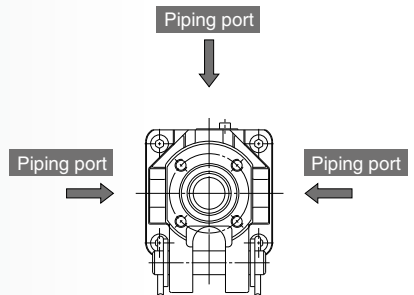

Clamp Cylinder with Lock: Magnetic Field Resistant Auto Switch (Rod Mounting Type)

CLK2G/CLK2P Series

ø40, ø50, ø63

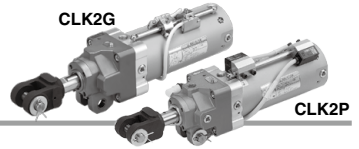

How to Order

Built-in standard magnet type

CLK2G **A** **50** - **100** **Y** - **B** - **P3DWASC**

Built-in strong magnet type

CLK2P **A** **50** - **100** **Y** - **B** - **P79WSE**

Clevis width

A	16.5 mm	ø40, ø50, ø63
B	19.5 mm	ø50, ø63
C	12.5 mm	ø40, ø50, ø63

Bore size

40	40 mm
50	50 mm
63	63 mm

Port type

Nil	Rc
TN	NPT
TF	G

Cylinder stroke

50, 75, 100, 125, 150

End bracket

Nil	None
I	Single knuckle joint (M6 without tap)
IA	Single knuckle joint (M6 with tap)
Y	Double knuckle joint (M6 without tap)
YA	Double knuckle joint (M6 with tap)

Note) Pin (for knuckle), cotter pin and flat washer are provided as a standard for Y and YA.

Option

Nil	None
B	Limit switch mounting base ^{Note 1)}
D	Dog fitting ^{Note 1)}
L	Foot
K ^{Note 2)}	Pedestal (for 75, 100, 150 strokes only)

Note 1) Only IA or YA (M6 with tap) is selectable as the end bracket for the B, D, and BD types.
 Note 2) Only applicable to clevis width A (16.5 mm).

Built-in Standard (Strong) Magnet Cylinder Part No.

- Built-in standard (strong) magnet type without auto switch and switch mounting rod
 Symbol for the auto switch type is "Nil" as shown below.
 CLK2G: (Example) CLK2GA50-50Y
 CLK2P: (Example) CLK2PA50-50Y
- Built-in standard (strong) magnet type without auto switch, with switch mounting rod
 Symbol for the auto switch type is "P" as shown below.
 CLK2G: (Example) CLK2GA50-50Y-P
 CLK2P: (Example) CLK2PA50-50Y-P

Made to Order
 For details, refer to page 465.

Number of auto switches

Nil	2 pcs.
S	1 pc.
n	"n" pcs. (n = 3, 4, 5...n)

Auto switch

Nil	Without auto switch, Without switch mounting rod
P	Without auto switch, With switch mounting rod
Auto switch model	With auto switch, With switch mounting rod

Note) Select applicable auto switch models from the table below.

Switch mounting rod position

Nil	Top
L	Left
R	Right

Note 1) Viewed from the rod end.
 Note 2) When the auto switch D-P7 or D-P4 is mounted, by-pass piping and a switch mounting rod cannot be placed at the same position. (D-P3DWA type is only available)

Port/Bypass piping position

* Refer to page 465.

Locking direction

B	Retraction locking
F	Extension locking

Applicable Magnetic Field Resistant Auto Switches (Refer to pages 1341 to 1435 for detailed auto switch specifications.)

Applicable cylinder series	Type	Auto switch model	Applicable magnetic field	Electrical entry	Indicator light	Wiring (Pin no. in use)	Load voltage	Lead wire length	Applicable load	
CLK2G series	Solid state auto switch	D-P3DWASC	AC magnetic field (Single-phase AC welding magnetic field)	Pre-wired connector	2-color display	2-wire (3-4)	24 VDC	0.3 m	Relay, PLC	
		D-P3DWASE								2-wire (1-4)
		D-P3DWA				2-wire				
		D-P3DWAL								2-wire (3-4)
		D-P3DWAZ		2-wire (1-4)		5 m				
		D-P4DWSC						Pre-wired connector		2-wire (3-4)
		D-P4DWSE		2-wire (1-4)						
		D-P4DWL				2-wire				3 m
D-P4DWZ	2-wire	5 m								
CLK2P series			Reed auto switch	D-P79WSE	DC / AC magnetic field	Pre-wired connector	2-color display	2-wire (1-4)	24 VDC	0.3 m
	D-P74L	Grommet		1-color display		2-wire	24 VDC	3 m		
	D-P74Z								100 VAC	5 m

Note 1) Refer to page 481 when ordering the auto switch mounting bracket assembly or switch mounting rod assembly.
 Note 2) For D-P3DWA□, auto switches and auto switch mounting brackets are shipped together (not assembled).

Clamp Cylinder with Lock With Magnetic Field Resistant Auto Switch **CLK2G/CLK2P Series**

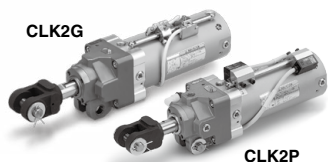

Symbol

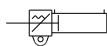

Retraction locking type



Extension locking type

Standard Stroke

Bore size (mm)	Standard stroke (mm)
40, 50, 63	50, 75, 100, 125, 150

Port/Bypass Piping Position

Symbol	Port position	Bypass piping position	Locking direction	
			B: Retraction locking	F: Extension locking
Nil	Port on top	Bypass piping on left		
2	Port on left	Bypass piping on right		
3	Port on right	Bypass piping on left		
4	Port on top	Bypass piping on right	—	
5	Port on left	Bypass piping on top	—	
6	Port on right	Bypass piping on top	—	

→ Port Bypass piping



Made to Order: Individual Specifications
(For details, refer to pages 484 and 485.)

Symbol	Specifications
-X1604	Unlock-port separate piping type: ø40 to ø63 only

Made to Order

[Click here for details](#)

Symbol	Specifications
-XC87	Heavy duty specification: ø40 to ø63 only

For specifications with auto switches, refer to pages 480 to 483.

- Minimum Stroke for Auto Switch Mounting
- Auto Switch Proper Mounting Position (for Stroke End Detection) and its Mounting Height
- Operating Range
- Auto Switch Mounting Bracket/Part No.

Clamp Cylinder with Lock Specifications

Bore size	40	50	63
Action	Double acting, Single rod		
Fluid	Air		
Proof pressure	1.5 MPa		
Maximum operating pressure	1.0 MPa		
Minimum operating pressure	0.2 MPa		
Locking action	Spring locking		
Locking pressure	0.05 MPa		
Locking direction	One direction (Retraction, Extension)		
Lock holding force N (Max. static load) <small>Note 1)</small>	629	982	1559
Lock application	Drop prevention, Position holding		
Ambient and fluid temperature	Without auto switch: -10°C to 70°C With auto switch: -10°C to 60°C		
Lubrication	Not required (Non-lube)		
Piston speed	50 to 500 mm/s		
Stroke length tolerance	+1.0/0		
Cushion	Retraction direction (Head end): With air cushion		
Mounting	Double clevis <small>Note 2)</small>		

Note 1) The holding force (max. static load) shows the maximum capability and does not show the normal holding capability. So, select an appropriate cylinder while referring to page 487.

Note 2) Pin (for clevis), cotter pin, flat washer are equipped as standard.

Clevis width	16.5 mm 19.5 mm 12.5 mm	ø40, ø50, ø63 ø50, ø63 ø40, ø50, ø63
--------------	-------------------------------	--

Weight (Basic weight is for a 0 mm stroke.)

Bore size (mm)		40	50	63
Cylinder basic weight	CLK2G series	B: 1.05 F: 1.11	B: 1.48 F: 1.54	B: 1.96 F: 2.02
	CLK2P series	B: 1.12 F: 1.18	B: 1.49 F: 1.55	B: 2.06 F: 2.08
	Additional weight per 25 mm stroke	0.08	0.11	0.13
Single knuckle joint		0.25	0.20	
Double knuckle joint (Pin, cotter pin, flat washer are included.)		0.36	0.34	
Limit switch mounting base		0.22		
Dog fitting		0.12		
Foot		0.24		
Pedestal		2.04		

Note) The above values do not include the weight of the auto switch and auto switch mounting bracket.

Calculation
 Example) CLK2PB50-100Y-B
 • Basic weight ... 1.49 (ø50)
 • Additional weight ... 0.11/25 mm
 • Cylinder stroke ... 100 mm
 • Double knuckle joint ... 0.34 (Y)
 $1.49 + 0.11 \times 100 / 25 + 0.34 = 2.27$ kg

Theoretical Output

Bore size (mm)	Rod size (mm)	Operating direction	Piston area (mm ²)	Operating pressure (MPa)			
				0.3	0.4	0.5	0.6
40	16	OUT	1260	378	504	630	756
		IN	1060	318	424	530	636
50	20	OUT	1960	588	784	980	1180
		IN	1650	495	660	825	990
63	20	OUT	3120	934	1250	1560	1870
		IN	2800	840	1120	1400	1680

Accessories (Options)

Symbol	Description	Parts no.					
		CLK2GA/CLK2PA series		CLK2GB/CLK2PB series		CLK2GC/CLK2PC series	
		40	50, 63	50, 63	40	50, 63	
I	Single knuckle joint	M6 without tap	CLK-I04		CKB-I04	CLK-I04	CKB-I04
IA		M6 with tap	CLK-IA04		CKB-IA04	CLK-IA04	CKB-IA04
Y	Double knuckle joint (knuckle pin, cotter pin, flat washer are equipped as a standard.)	M6 without tap	CLK-Y04	CKA-Y04	CKB-Y04	CLKC-Y04	CKC-Y04
YA		M6 with tap	CLK-YA04	CKA-YA04	CKB-YA04	CLKC-YA04	CKC-YA04
B	Limit switch mounting base				CK-B04		
D	Dog fitting				CK-D04		
L	Foot				CK-L04		
K	Pedestal	For 75 stroke	CKA-K075				
		For 100 stroke	CKA-K100				
		For 150 stroke	CKA-K150				

CLK2G/CLK2P Series

Construction: CLK2G□40/50/63 Built-in Standard Magnet Type / Rod Mounting Type Auto Switch

Retraction locking (B)

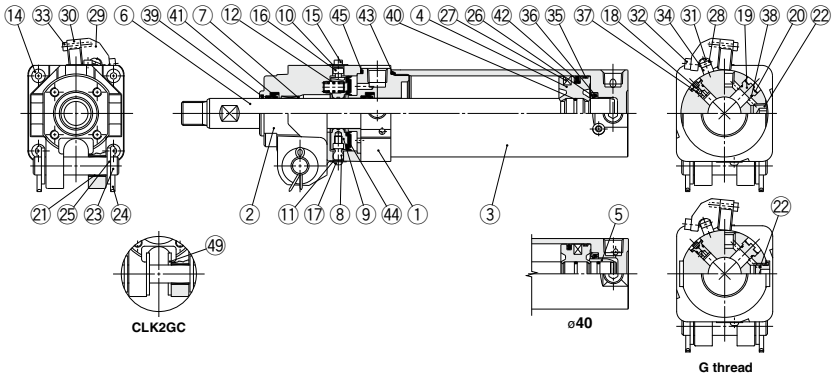

Extension locking (F)

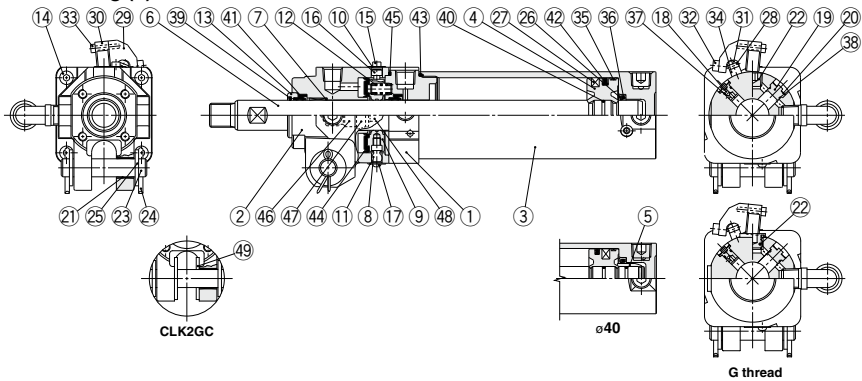

Component Parts

No.	Description	Material	Qty	Note
1	Rod cover	Aluminum alloy	1	Hard anodized
2	Cover	Aluminum alloy	1	Hard anodized
3	Tube cover	Aluminum alloy	1	Hard anodized
4	Piston	Aluminum alloy	1	Chromated
5	Cushion ring	Aluminum alloy	1	Anodized, ø40 only
6	Piston rod	Carbon steel	1	Hard chrome plated
7	Bushing	Bearing alloy	1	
8	Pivot	Carbon steel	1	Heat treated, Electroless nickel plated
9	Lock ring	Carbon steel	1	Zinc chromated
10	Dust cover	Stainless steel	1	
11	Dust cover	Stainless steel	1	
12	Brake spring	Steel wire	2	Zinc chromated
13	Retainer plate	Aluminum alloy	1	Anodized, Extension locking only
14	Hexagon socket head cap screw	Chrome molybdenum steel	4	
15	Hexagon socket head cap screw	Chrome molybdenum steel	1	
16	Hexagon socket head cap screw	Chrome molybdenum steel	1	
17	Round head Phillips screw	Chrome molybdenum steel	1	
18	Cushion valve	Aluminum alloy	1	
19	Plug	Aluminum alloy	1	
20	Retaining ring	Spring steel	2	
21	Clevis bushing	Bearing alloy	2	
22	Hexagon socket head plug	Carbon steel	4(5)	Rc 1/4, 5 pcs. of extension locking
23	Pin	Carbon steel	1	
24	Cotter pin	Low carbon steel wire rod	2	
25	Flat washer	Rolled steel	2	

No.	Description	Material	Qty	Note
26	Cushion seal retainer	Rolled steel	1	Zinc chromated
27	Magnet	—	1	
28	Switch mounting rod	Carbon steel	1	Zinc chromated
29	Auto switch mounting bracket	Aluminum alloy	—	
30	Magnetic field resistant auto switch	—	—	
31	Hexagon socket head button screw	Chrome molybdenum steel	2	M4 x 0.7 x 12 L
32	Hexagon socket head cap screw	Chrome molybdenum steel	2	M4 x 0.7 x 8 L
33	Hexagon socket head cap screw	Chrome molybdenum steel	2	M3 x 0.5 x 14 L
34	Switch mounting spacer	Aluminum alloy	1(2)	2 pcs. for ø63
35	Wear ring	Resin	1	
36	Cushion seal	Urethane	1	
37	Cushion valve seal	NBR	1	
38	Plug gasket	NBR	1	
39	Coil scraper	Phosphor bronze	1	
40	Piston gasket	NBR	1	
41	Rod seal	NBR	2	
42	Piston seal	NBR	1(2)	2 pcs. for ø40
43	Tube gasket	NBR	1	
44	Lock ring seal	NBR	1	
45	O-ring	NBR	1	
46	FR One-touch fitting	2		Extension locking only
47	Spatter cover	2		Extension locking only
48	FR double layer tube	1		Extension locking only
49	Spacer	Bearing alloy	2	CLK2GC only

Clamp Cylinder with Lock With Magnetic Field Resistant Auto Switch **CLK2G/CLK2P Series**

Construction: CLK2P□40/50/63 Built-in Strong Magnet Type / Rod Mounting Type Auto Switch

Retraction locking (B)

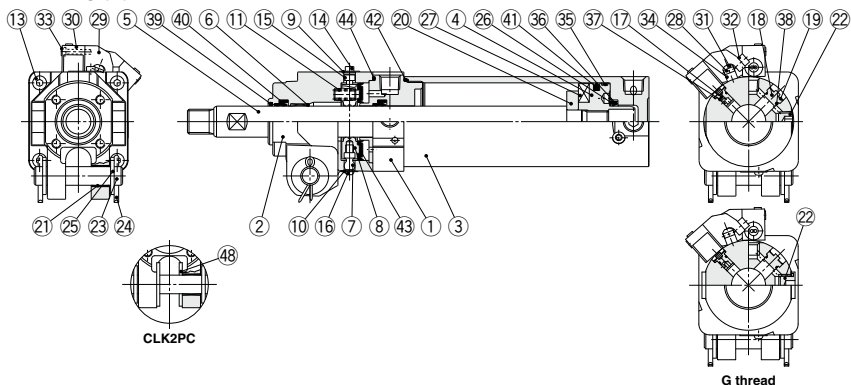

Extension locking (F)

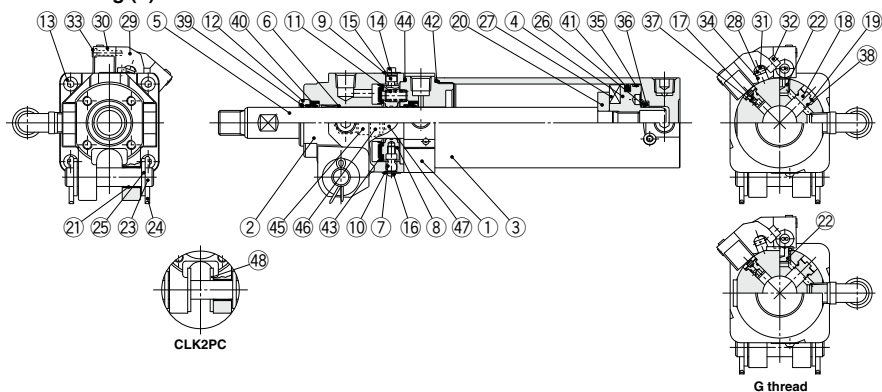

Component Parts

No.	Description	Material	Qty	Note
1	Rod cover	Aluminum alloy	1	Hard anodized
2	Cover	Aluminum alloy	1	Hard anodized
3	Tube cover	Aluminum alloy	1	Hard anodized
4	Piston	Aluminum alloy	1	Chromated
5	Piston rod	Carbon steel	1	Hard chrome plated
6	Bushing	Bearing alloy	1	
7	Pivot	Carbon steel	1	Heat treated, Electroless nickel plated
8	Lock ring	Carbon steel	1	Zinc chromated
9	Dust cover	Stainless steel	1	
10	Dust cover	Stainless steel	1	
11	Brake spring	Steel wire	2	Zinc chromated
12	Retainer plate	Aluminum alloy	1	Anodized, Extension locking only
13	Hexagon socket head cap screw	Chrome molybdenum steel	4	
14	Hexagon socket head cap screw	Chrome molybdenum steel	1	
15	Hexagon socket head cap screw	Chrome molybdenum steel	1	
16	Round head Phillips screw	Chrome molybdenum steel	1	
17	Cushion valve	Aluminum alloy	1	
18	Plug	Aluminum alloy	1	
19	Retaining ring	Spring steel	2	
20	Magnet holder	Aluminum alloy	1	Chromated
21	Clevis bushing	Bearing alloy	2	
22	Hexagon socket head plug	Carbon steel	4(5)	Rc 1/4, 5 pcs. of extension locking
23	Pin	Carbon steel	1	
24	Cotter pin	Low carbon steel wire rod	2	

No.	Description	Material	Qty	Note
25	Flat washer	Rolled steel	2	
26	Cushion seal retainer	Rolled steel	1	Zinc chromated
27	Magnet	—	1	
28	Switch mounting rod	Carbon steel	1	Zinc chromated
29	Auto switch mounting bracket	Aluminum alloy	—	
30	Magnetic field resistant auto switch	—	—	
31	Hexagon socket head button screw	Chrome molybdenum steel	2	M4 x 0.7 x 12 L
32	Hexagon socket head cap screw	Chrome molybdenum steel	2 pcs. per switch	M4 x 0.7 x 8 L
33	Hexagon socket head cap screw	Chrome molybdenum steel	2 pcs. per switch	M3 x 0.5 x 16 L
34	Switch mounting spacer	Aluminum alloy	1(2)	2 pcs. for ø63
35	Wear ring	Resin	1	
36	Cushion seal	Urethane	1	
37	Cushion valve seal	NBR	1	
38	Plug gasket	NBR	1	
39	Coil scraper	Phosphor bronze	1	
40	Rod seal	NBR	2	
41	Piston seal	NBR	1	
42	Tube gasket	NBR	1	
43	Lock ring seal	NBR	1	
44	O-ring	NBR	1	
45	FR One-touch fitting		2	Extension locking only
46	Spatter cover		2	Extension locking only
47	FR double layer tube		1	Extension locking only
48	Spacer	Bearing alloy	2	CLK2PC only

Clamp Cylinder with Lock With Magnetic Field Resistant Auto Switch **CLK2G/CLK2P Series**

Dimensions: CLK2P□40/50/63

Built-in Strong Magnet Type / With Magnetic Field Resistant Reed Auto Switch (D-P79WSE)

Retraction locking (B)

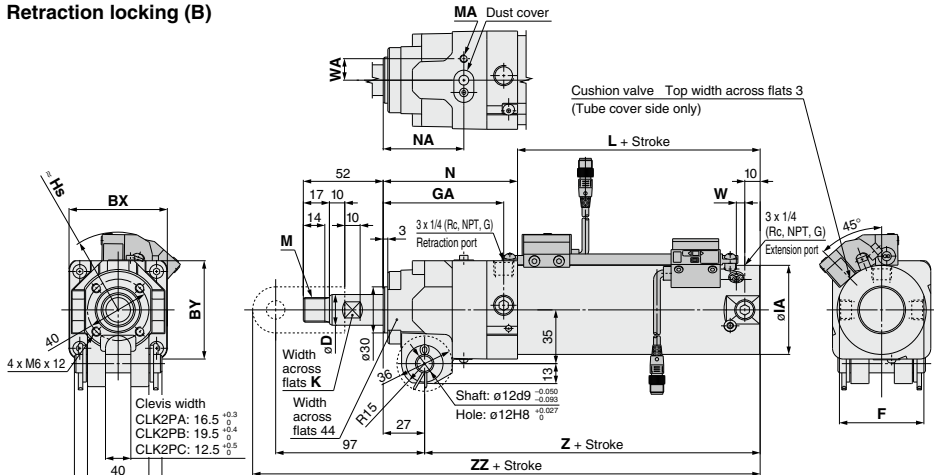

Symbol	BX	BY	D	F	GA	IA	K	L	M	MA	N	NA	W	WA	Z	ZZ	Hs
40	56	54	16	44	77	47	14	65	M12 x 1.5	M4 x 7	86	51.5	5	12.5	124	236	46
50	64	64	20	55	78.5	58	17	58	M16 x 1.5	M4 x 7	87.5	52.5	5.5	14	118.5	230.5	51
63	74	74	20	69	82	72	17	58	M16 x 1.5	M5 x 7	91	53.5	5.5	19	122	234	57.5

Note) Refer to pages 478 and 479 for Accessories.

Extension locking (F)

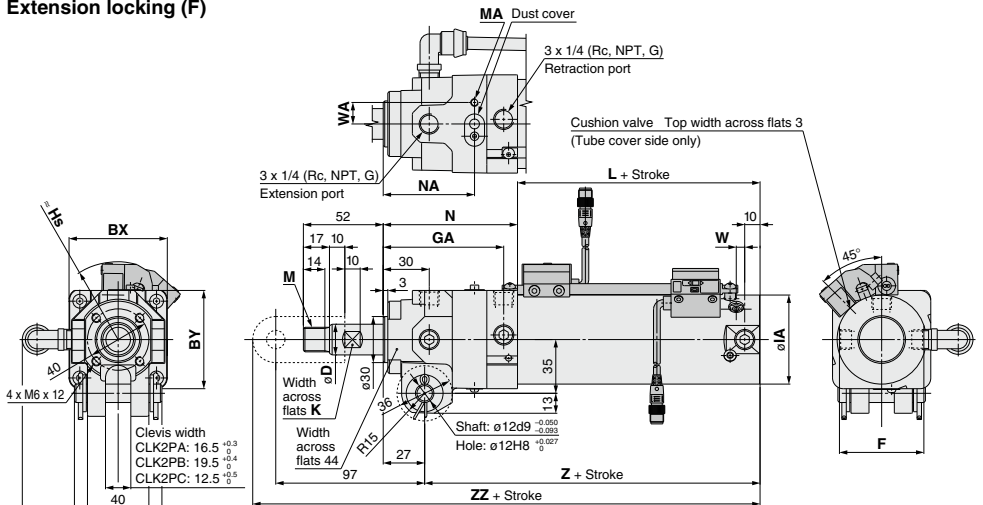

Symbol	BX	BY	D	F	GA	IA	K	L	M	MA	N	NA	T	W	WA	Z	ZZ	Hs
40	56	54	16	44	77	47	14	65	M12 x 1.5	M4 x 7	86	59	57	5	12.5	124	236	46
50	64	64	20	55	78.5	58	17	58	M16 x 1.5	M4 x 7	87.5	59.5	60	5.5	14	118.5	230.5	51
63	74	74	20	69	82	72	17	58	M16 x 1.5	M5 x 7	91	61	67	5.5	19	122	234	57.5

Note) Refer to pages 478 and 479 for Accessories.

Clamp Cylinder with Lock: Magnetic Field Resistant Auto Switch (Band Mounting Type)

CLK2 Series

ø32, ø40, ø50, ø63



How to Order

CLK2 **A** **50** **□** - **100** **Y** **□** - **B** **□** - **□**
 CLK2 **G** **A** **50** **□** - **100** **Y** **□** - **B** **□** - **□**

For how to order auto switch/ auto switch mounting bracket, refer to below.

Built-in magnet for auto switch

Clevis width

	12 mm	ø32
A	16.5 mm	ø40, ø50, ø63
B	19.5 mm	ø50, ø63
C	12.5 mm	ø40, ø50, ø63

Bore size

32	32 mm
40	40 mm
50	50 mm
63	63 mm

Port type

Nil	Rc
TN	NPT
TF	G

Note) G thread is not available for ø32.

Cylinder stroke

50, 75, 100, 125, 150

• Made to Order

For details, refer to page 472.

• Port/Bypass piping position

* Refer to page 472.

• Locking direction

B	Retraction locking
F	Extension locking

• Option

Nil	None
B	Limit switch mounting base <small>Note 2)</small>
D	Dog fitting <small>Note 2)</small>
L	Foot
K <small>Note 3)</small>	Pedestal (for 75, 100, 150 strokes only)

End bracket

Nil	None
I	Single knuckle joint (M6 without tap)
IA	Single knuckle joint (M6 with tap)
Y	Double knuckle joint (M6 without tap)
YA	Double knuckle joint (M6 with tap)

Note 1) IA and YA are not available for ø32.

Note 2) Knuckle pin, cotter pin and flat washer are provided as a standard for Y and YA.

Magnetic Field Resistant Auto Switch D-P4DW□□ Type / Band Mounting Compliant

Band mounting of the magnetic field resistant auto switch (D-P4DW□□ type) to the built-in standard magnet clamp cylinder (the CLK2G32 to 63 series) is possible by ordering the auto switch mounting bracket and the auto switch individually.

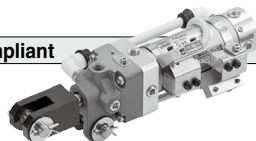

How to Order

Please order the switch mounting bracket, auto switch and clamp cylinder individually. Refer to the below table for auto switch mounting bracket part numbers.

Auto switch component part no.	Applicable auto switch	Applicable clamp cylinder with lock
BA8-032	D-P4DW□	CLK2G□32
BA8-040		CLK2G□40
BA8-050		CLK2G□50
BA8-063		CLK2G□63

Note) Refer to page 481 for mounting brackets.

Ordering Example for CLK2G32 to 63

- Example case ① Built-in standard magnet cylinder:
CLK2GA50-50Y-B 1
- Example case ② Magnetic field resistant auto switch:
D-P4DWSC 2
- Example case ③ Auto switch mounting bracket:
BA8-050 2

Note 1) Please order the same quantity for the auto switch mounting bracket and the magnetic field resistant auto switch respectively.

Note 2) Band mounting for the magnetic field resistant auto switch D-P79WSE type, D-P74□ type is not applicable.

Applicable Magnetic Field Resistant Auto Switches (Refer to pages 1341 to 1435 for detailed auto switch specifications.)

Applicable cylinder series	Type	Auto switch model	Applicable magnetic field	Electrical entry	Indicator light	Wiring (Pin no. in use)	Load voltage	Lead wire length	Applicable load
CLK2G series	Solid state auto switch	P4DWSC	AC magnetic field (Single-phase AC welding magnetic field)	Pre-wired connector	2-color display	2-wire (3-4)	24 VDC	0.3 m	Relay, PLC
		P4DWSE				2-wire (1-4)			
		P4DWL		2-wire		3 m			
		P4DWZ				5 m			
				Grommet					

Clamp Cylinder with Lock: Standard Auto Switch (Rod Mounting/Band Mounting Type)

CLK2G Series

ø32, ø40, ø50, ø63



How to Order

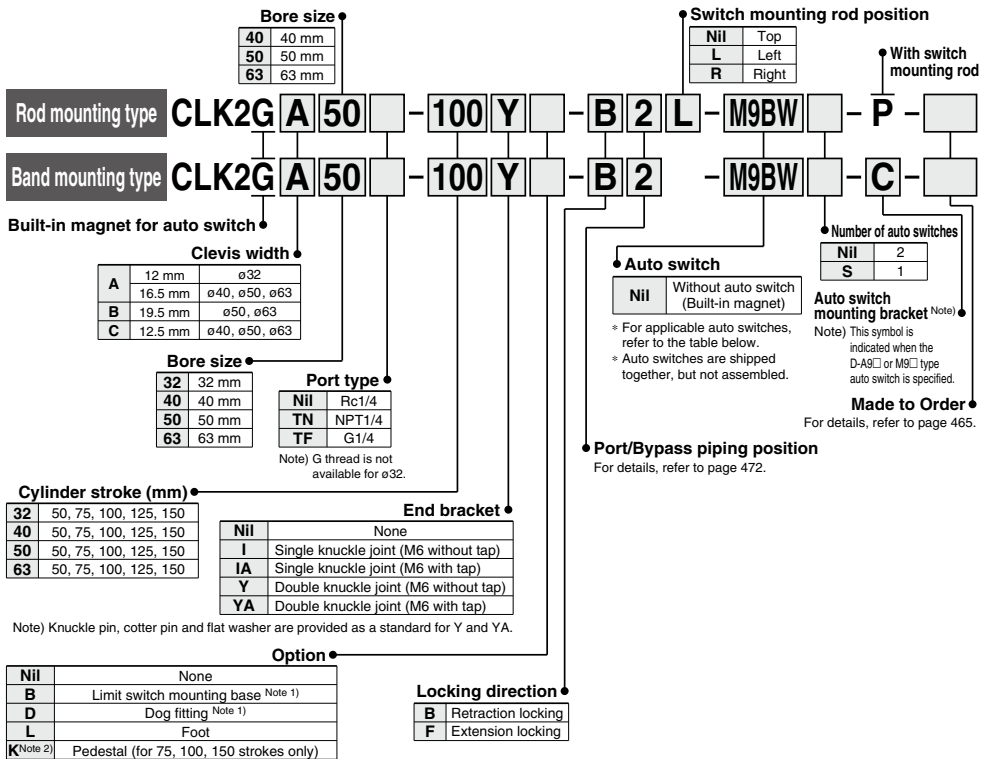

Note 1) Only IA or YA (M6 with tap) is selectable as the end bracket for the B, D, and BD types.
Note 2) Only applicable to clevis width A (16.5 mm).

Standard Auto Switches Standard auto switches cannot be used under a strong magnetic field.

Type	Special function	Electrical entry	Indicator/light	Wiring (Output)	Load voltage		Auto switch model	Lead wire length [m]				Pre-wired connector	Applicable load	
					DC	AC		0.5 (Nil)	1 (M)	3 (L)	5 (Z)		Relay, PLC	Relay, PLC
Solid state auto switch	—	Grommet	Yes	3-wire (NPN)	5 V, 12 V	—	M9N	●	●	●	○	○		
				3-wire (PNP)			M9P	●	●	●	○	○		
				2-wire	M9B		●	●	●	○	○			
				3-wire (NPN)	M9NW		●	●	●	○	○			
				3-wire (PNP)	M9PW		●	●	●	○	○			
				2-wire	M9BW		●	●	●	○	○			
	Water resistant (2-color indicator)	Grommet	Yes	3-wire (NPN)	5 V, 12 V	M9NA	○	○	●	○	○	○	IC circuit	Relay, PLC
				3-wire (PNP)		M9PA	○	○	●	○	○			
				2-wire	M9BA	○	○	●	○	○				
				2-wire	M9WA	○	○	●	○	○				
Reed auto switch	—	Grommet	Yes	3-wire (NPN equivalent)	5 V	—	A96	●	●	●	●	○	IC circuit	—
				2-wire	12 V	100 V	A93	●	●	●	●	○	○*	Relay, PLC
					5 V, 12 V	100 V or less	A90	●	●	●	●	○	○*	

*1 The load voltage used is 24 VDC.

* Auto switches marked with "○" are produced upon receipt of order.

* Auto switches and mounting brackets are shipped together, (but not assembled).

* Lead wire length symbols: 0.5 m.....Nil (Example) M9NWV
1 m.....M (Example) M9NWW
3 m.....L (Example) M9NWL
5 m.....Z (Example) M9NWVZ



CLK2 Series



Symbol



Retraction locking type



Extension locking type

Standard Stroke

Bore size (mm)	Standard stroke (mm)
32, 40, 50, 63	50, 75, 100, 125, 150

Port/Bypass Piping Position

Symbol	Port position	Bypass piping position	Locking direction	
			B: Retraction locking	F: Extension locking
Nil	Port on top	Bypass piping on left		
2	Port on left	Bypass piping on right		
3	Port on right	Bypass piping on left		
4	Port on top	Bypass piping on right	—	
5	Port on left	Bypass piping on top	—	
6	Port on right	Bypass piping on top	—	

→ Port Bypass piping



Made to Order: Individual Specifications
(For details, refer to pages 484 and 485.)

Symbol	Specifications
-X1604	Unlock-port separate piping type: ø40 to ø63 only

Made to Order

[Click here for details](#)

Symbol	Specifications
-XC87	Heavy duty specification: ø40 to ø63 only

For specifications with auto switches, refer to pages 480 to 483.

- Minimum Stroke for Auto Switch Mounting
- Auto Switch Proper Mounting Position (for Stroke End Detection) and its Mounting Height
- Operating Range
- Auto Switch Mounting Bracket/Part No.

Clamp Cylinder with Lock Specifications

Bore size	32	40	50	63
Action	Double acting, Single rod			
Fluid	Air			
Proof pressure	1.5 MPa			
Maximum operating pressure	1.0 MPa			
Minimum operating pressure	0.2 MPa			
Locking action	Spring locking			
Locking pressure	0.05 MPa			
Locking direction	One direction (Retraction, Extension)			
Lock holding force N (Max. static load)	0.5 MPa or equivalent			
	402	629	982	1559
Lock application	Drop prevention, Position holding			
Ambient and fluid temperature	Without auto switch: -10°C to 70°C With auto switch: -10°C to 60°C			
Lubrication	Not required (Non-lube)			
Piston speed	50 to 500 mm/s			
Stroke length tolerance	+1.0/0			
Cushion	Retraction direction (Head end): With air cushion			
Mounting	Double clevis ^{Note 2)}			

Note 1) The holding force (max. static load) shows the maximum capability and does not show the normal holding capability. So, select an appropriate cylinder while referring to page 487.

Note 2) Pin (for clevis), cotter pin, flat washer are equipped as a standard.

Clevis width	12 mm	ø32
	16.5 mm	ø40, ø50, ø63
	19.5 mm	ø50, ø63
	12.5 mm	ø40, ø50, ø63

Weight (Basic weight is for a 0 mm stroke.)

Bore size (mm)		32	40	50	63
Cylinder basic weight	CLK2□ series	B: 0.51 F: 0.54	B: 1.05 F: 1.11	B: 1.48 F: 1.54	B: 1.96 F: 2.02
	Additional weight per 25 mm stroke	0.08	0.08	0.11	0.13
Single knuckle joint		0.25	0.25	0.20	
Double knuckle joint (Pin, cotter pin, flat washer are included.)		0.17	0.36	0.34	
Limit switch mounting base		—	—	0.22	
Dog fitting		—	—	0.12	
Foot		—	—	0.24	
Pedestal		—	—	2.04	

Calculation Example CLK2B50-100Y-B
 • Basic weight ... 1.48 (ø50)
 • Additional weight ... 0.11/25 mm
 • Cylinder stroke ... 100 mm
 • Double knuckle joint ... 0.34 (Y)
 $1.48 + 0.11 \times 100 / 25 + 0.34 = 2.26$ kg

Theoretical Output

Bore size (mm)	Rod size (mm)	Operating direction	Piston area (mm ²)	Operating pressure (MPa)			
				0.3	0.4	0.5	0.6
32	12	OUT	804	241	322	402	482
		IN	691	207	276	346	415
40	16	OUT	1260	378	504	630	756
		IN	1060	318	424	530	636
50	20	OUT	1960	588	784	980	1180
		IN	1650	495	660	825	990
63	20	OUT	3120	934	1250	1560	1870
		IN	2800	840	1120	1400	1680

Accessories (Options)

Symbol	Description	Parts no.					
		CLK2A series		CLK2B series		CLK2C series	
		32	40	50, 63	50, 63	40	50, 63
I	Single knuckle joint	M6 without tap	CLK-I03	CLK-I04	CCKB-I04	CLK-I04	CCKB-I04
IA	Single knuckle joint	M6 with tap	—	CLK-IA04	CCKB-IA04	CLK-IA04	CCKB-IA04
Y	Double knuckle joint (knuckle pin, cotter pin, flat washer are equipped as a standard.)	M6 without tap	CLK-Y03	CLK-Y04	CKA-Y04	CCKB-Y04	CLKC-Y04
YA	Double knuckle joint	M6 with tap	—	CLK-YA04	CKA-YA04	CCKB-YA04	CLKC-YA04
B	Limit switch mounting base	—	—	—	—	CK-B04	—
D	Dog fitting	—	—	—	—	CK-D04	—
L	Foot	—	—	—	—	CK-L04	—
K	Pedestal	For 75 stroke	—	CKA-K075	—	—	—
		For 100 stroke	—	CKA-K100	—	—	—
		For 150 stroke	—	CKA-K150	—	—	—

CLK2 Series

Construction: CLK2□A32

Retraction locking (B)

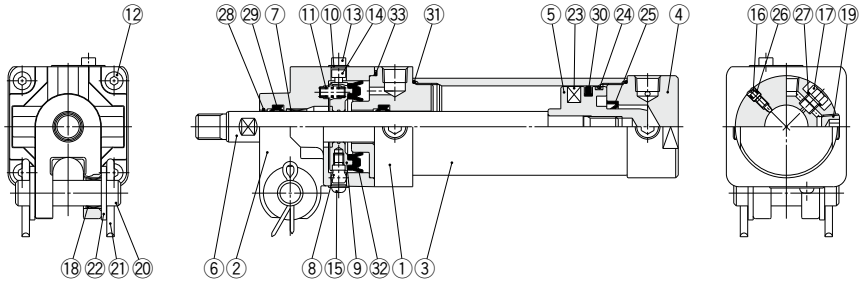

Extension locking (F)

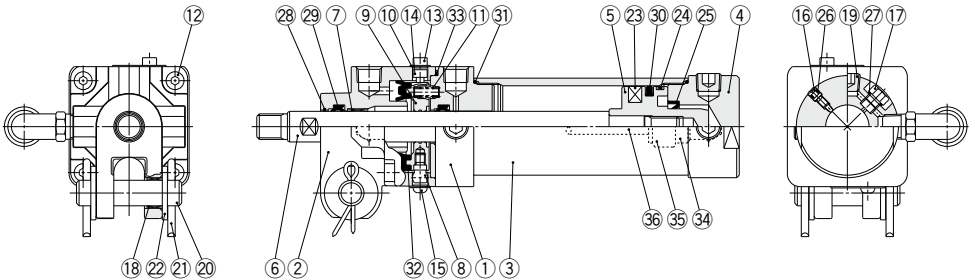

Component Parts

No.	Description	Material	Qty	Note
1	Rod cover	Aluminum alloy	1	Hard anodized
2	Cover	Aluminum alloy	1	Hard anodized
3	Cylinder tube	Aluminum alloy	1	Hard anodized
4	Head cover	Aluminum alloy	1	Chromated
5	Piston	Aluminum alloy	1	Chromated
6	Piston rod	Carbon steel	1	Hard chrome plated
7	Bushing	Bearing alloy	1	
8	Pivot	Carbon steel	1	Heat treated, Electroless nickel plated
9	Lock ring	Carbon steel	1	Zinc chromated
10	Dust cover	Stainless steel	2	
11	Brake spring	Steel wire	2	Zinc chromated
12	Hexagon socket head cap screw	Chrome molybdenum steel	4	
13	Hexagon socket head cap screw	Chrome molybdenum steel	1	
14	Hexagon socket head cap screw	Chrome molybdenum steel	1	
15	Round head Phillips screw	Chrome molybdenum steel	1	
16	Cushion valve	Free-cutting brass	1	Electroless nickel plated
17	Plug	Free-cutting brass	1	
18	Clevis bushing	Bearing alloy	2	

No.	Description	Material	Qty	Note
19	Hexagon socket head plug	Carbon steel	4(5)	Rc 1/8, 5 pcs. of extension locking
20	Pin	Carbon steel	1	
21	Cotter pin	Low carbon steel wire rod	2	
22	Flat washer	Rolled steel	2	
23	Magnet	—	1	CLK2GA32 only
24	Wear ring	Resin	1	
25	Cushion seal	NBR	1	
26	Cushion valve seal	NBR	1	
27	Plug seal	NBR	1	
28	Coil scraper	Phosphor bronze	1	
29	Rod seal	NBR	2	
30	Piston seal	NBR	1	
31	Tube gasket	NBR	2	
32	Lock ring seal	NBR	1	
33	O-ring	NBR	1	
34	FR One-touch fitting		2	Extension locking only
35	Spatter cover		2	Extension locking only
36	FR double layer tube		1	Extension locking only

Construction: CLK2□40/50/63

Retraction locking (B)

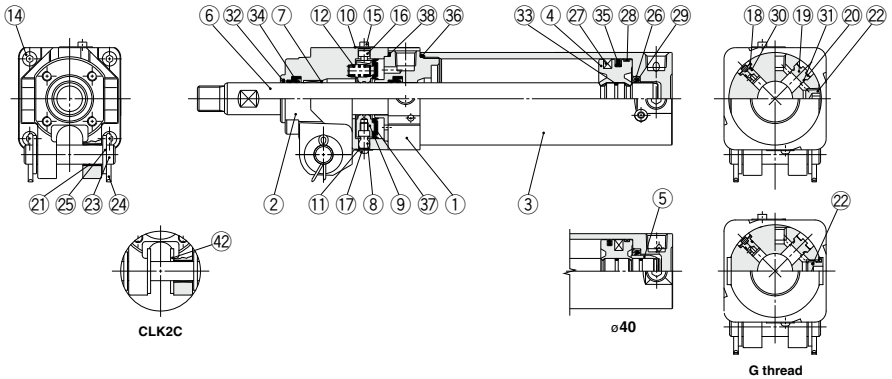

Extension locking (F)

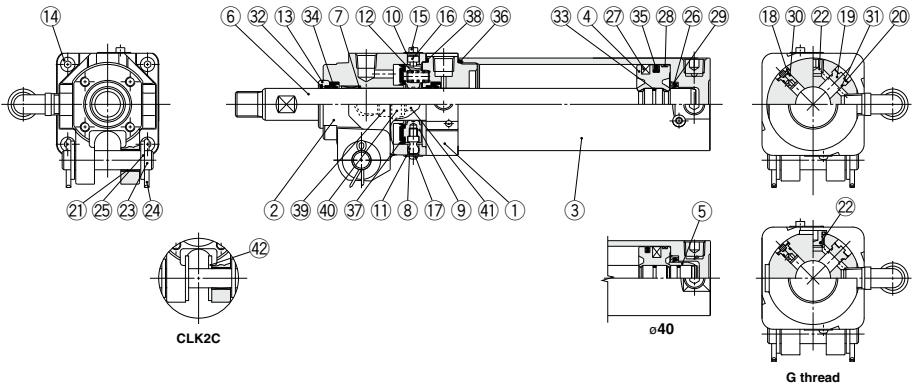

Component Parts

No.	Description	Material	Qty	Note
1	Rod cover	Aluminum alloy	1	Hard anodized
2	Cover	Aluminum alloy	1	Hard anodized
3	Tube cover	Aluminum alloy	1	Hard anodized
4	Piston	Aluminum alloy	1	Chromated
5	Cushion ring	Aluminum alloy	1	ø40 Anodized
6	Piston rod	Carbon steel	1	Hard chrome plated
7	Bushing	Bearing alloy	1	
8	Pivot	Carbon steel	1	Heat treated, Electroless nickel plated
9	Lock ring	Carbon steel	1	Zinc chromated
10	Dust cover	Stainless steel	1	
11	Dust cover	Stainless steel	1	
12	Brake spring	Steel wire	2	Zinc chromated
13	Retainer plate	Aluminum alloy	1	Anodized, Extension locking only
14	Hexagon socket head cap screw	Chrome molybdenum steel	4	
15	Hexagon socket head cap screw	Chrome molybdenum steel	1	
16	Hexagon socket head cap screw	Chrome molybdenum steel	1	
17	Round head Phillips screw	Chrome molybdenum steel	1	
18	Cushion valve	Aluminum alloy	1	
19	Plug	Aluminum alloy	1	
20	Retaining ring	Spring steel	2	
21	Clevis bushing	Bearing alloy	2	

No.	Description	Material	Qty	Note
22	Hexagon socket head plug	Carbon steel	4(5)	Rc 1/4, 5 pcs. of extension locking
23	Pin	Carbon steel	1	
24	Cotter pin	Low carbon steel wire rod	2	
25	Flat washer	Rolled steel	2	
26	Cushion seal retainer	Rolled steel	1	Zinc chromated
27	Magnet	—	1	CLK2G only
28	Wear ring	Resin	1	
29	Cushion seal	Urethane	1	
30	Cushion valve seal	NBR	1	
31	Plug gasket	NBR	1	
32	Coil scraper	Phosphor bronze	1	
33	Piston gasket	NBR	1(2)	2 pcs. for ø40
34	Rod seal	NBR	2	
35	Piston seal	NBR	1	
36	Tube gasket	NBR	1	
37	Lock ring seal	NBR	1	
38	O-ring	NBR	1	
39	FR One-touch fitting		2	Extension locking only
40	Spatter cover		2	Extension locking only
41	FR double layer tube		1	Extension locking only
42	Spacer	Bearing alloy	2	CLK2C only

CLK2 Series Accessories 1

Single Knuckle Joint

For $\phi 32$

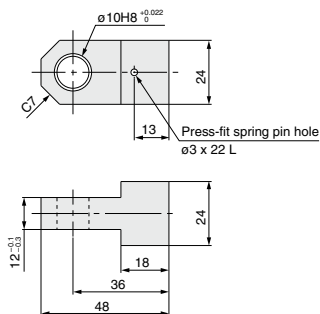

Double Knuckle Joint

For $\phi 32$

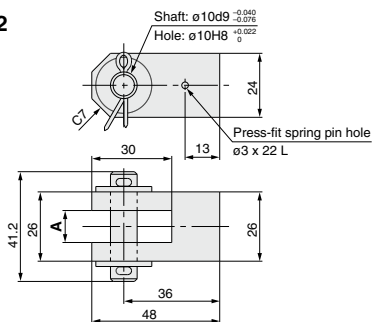

For $\phi 40, \phi 50, \phi 63$

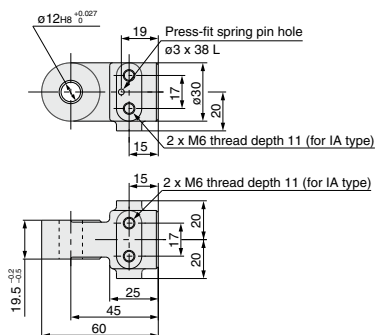

For $\phi 40, \phi 50, \phi 63$

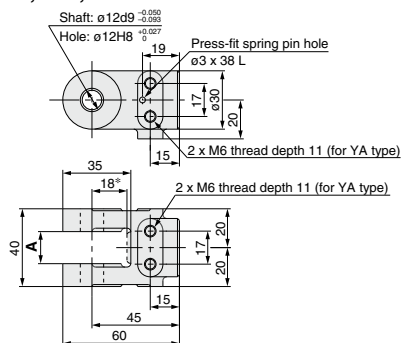

Part no.	Rod end bracket symbol	Applicable clamp cylinder
CLK-I03	I (M6 without tap)	CLK2□A32 series
CLK-I04	I (M6 without tap)	CLK2□A40 series
CLK-IA04	IA (M6 with tap)	CLK2□B40 series
CKB-I04	I (M6 without tap)	CLK2□A50 to 63 series
CKB-IA04	IA (M6 with tap)	CLK2□B50 to 63 series

Note) A spring pin is attached to the single knuckle joint as a standard.

Part no.	Rod end bracket symbol	A	Applicable clamp cylinder
CLK-Y03	Y (M6 without tap)	12 ^{+0.5} / _{+0.2}	CLK2□A32 series
CLK-Y04	Y (M6 without tap)	16.5 ^{+0.3} / ₀	CLK2□A40 series
CLK-YA04	YA (M6 with tap)		CLK2□A50 to 63 series
CKA-Y04	Y (M6 without tap)	19.5 ^{+0.4} / ₀	CLK2□A50 to 63 series
CKA-YA04	YA (M6 with tap)		CLK2□B50 to 63 series
CKB-Y04	Y (M6 without tap)	12.5 ^{+0.5} / ₀	CLK2□C40 series
CKB-YA04	YA (M6 with tap)		CLK2□C50 to 63 series
CKC-Y04	Y (M6 without tap)	12.5 ^{+0.5} / ₀	CLK2□C50 to 63 series
CKC-YA04	YA (M6 with tap)		CLK2□C50 to 63 series

Note 1) Pin (for knuckle), cotter pin and flat washer are attached to the double knuckle joint as a standard.

Note 2) The dimension with * shows the value when mounted on the piston rod.

Pin (for Clevis/Double Knuckle Joint)

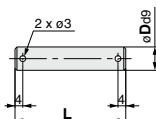

Part no.	D	L	Applicable clamp cylinder
CLK-P03	10 ^{-0.040} / _{-0.076}	41.2	CLK2□A32 series
CK-P04	12 ^{-0.050} / _{-0.093}	57	CLK2□□40 to 63 series

Note) Cotter pin and flat washer are provided as a standard.

CLK2 Series Accessories 2

Limit Switch Mounting Base/Dog Fitting

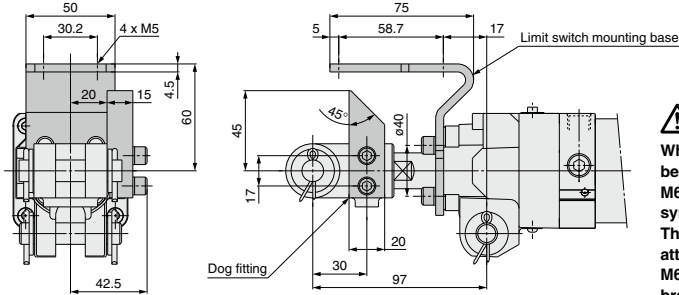

When you attach a dog fitting, be sure to use a knuckle joint, M6 with tap (rod end bracket symbol IA or YA). The dog fitting cannot be attached to the knuckle joint, M6 without tap (rod end bracket symbol I or Y).

Part no.	Option symbol	Name	Applicable clamp cylinder
CK-B04	B	Limit switch mounting base	CLK2□40 to 63 series
CK-D04	D	Dog fitting	

Note 1) Limit switch mounting base and dog fitting can be repositioned by removing the hexagon socket head cap screw.

Note 2) When ordering the limit switch base and the dog bracket individually, a spring washer for the mounting bolt (hexagon socket head cap screw) will be attached as a standard.

Pedestal

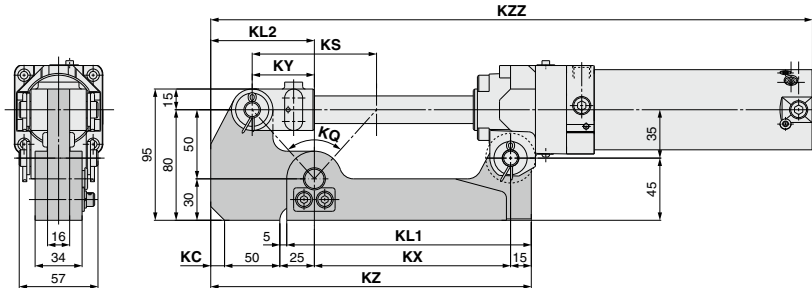

Type	KL1	KL2	KX	KZ	KY	KS	KQ	KC	KZZ			Applicable cylinder
									Bore size			
CKA-K075	167	75	132	222	35	70	69° 59'	0	396 (406)	400.5	404	CLK2□A40-75Y, CLK2□A50-75Y, CLK2□A63-75Y
CKA-K100	177	75	142	232	45	90	83° 58'	0	431 (441)	435.5	439	CLK2□A40-100Y, CLK2□A50-100Y, CLK2□A63-100Y
CKA-K150	202	85	167	267	70	140	108° 55'	10	516 (526)	520.5	524	CLK2□A40-150Y, CLK2□A50-150Y, CLK2□A63-150Y

Note) () denotes the dimensions for CLK2PA40.

Foot

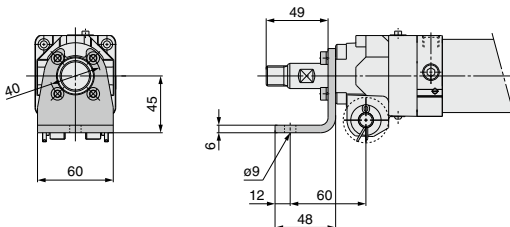

Part no.	Option symbol	Applicable clamp cylinder
CK-L04	L	CLK2□40 to 63 series

Note 1) Mounting bolts (hexagon socket head cap screws) and spring washers are attached to the foot as standard.
Note 2) When mounting the cylinder, use both the foot and clevis pin. Please avoid using the foot by itself as this may result in damage.

CLK2 Series

Auto Switch Mounting (Rod Mounting Type)

Auto Switch Proper Mounting Position (Detection at Stroke End) and Its Mounting Height

Rod mounting D-P3DWA□ type

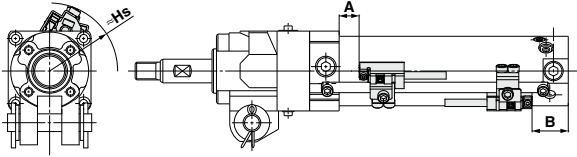

D-P4DW□ type

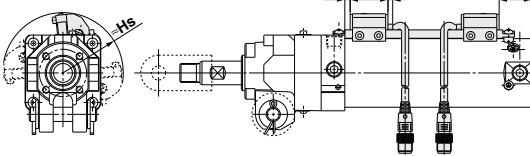

Note) The above drawing is the auto switch rod mounting example for the D-P4DWS□ type.

D-P79WSE type P74□ type

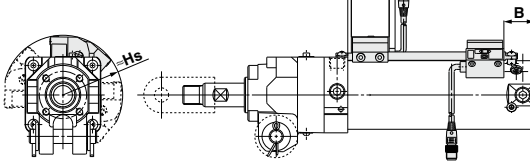

Note) The above drawing is the auto switch rod mounting example for the D-P49WSE type.

D-M9□ type D-A9□ type

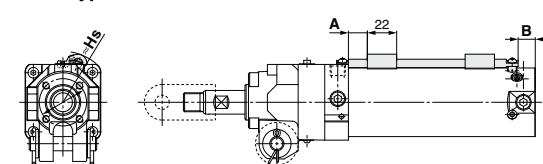

Auto Switch Mounting Position and Its Height: Rod Mounting

Unit: mm

Auto switch model	Symbol	Auto switch set value and its height		
		40	50	63
D-P3DWA□	A	10.5	7	7
	B	23	30	30
	Hs	46.5	52	59
D-P4DW□	A	8	4.5	4.5
	B	20.5	27.5	27.5
	Hs	45.5	51	58.5
D-P79WSE D-P74□	A	5.5	0	0
	B	27.5	26	26
	Hs	46	51	58
D-M9□	A	15	11.5	11.5
	B	27.5	34.5	34.5
	Hs	39	44.5	51.5
D-A9□	A	11	8.5	8.5
	B	23.5	30.5	30.5
	Hs	39	44.5	51.5

Note 1) The mounting position should be referred for reference only for the auto switch mounting position at the stroke end detection. Adjust the auto switch after confirming the operation to set actually.

Note 2) The applicable bore sizes of the CLK2GB (Cleviss width 19.5 mm) are $\phi 50$ and $\phi 63$.

Note 3) A/B dimensions are the distance from the standard position (above drawing) to the end surface of the auto switch.

Note 4) The auto switch mounting position is temporarily set at the time of shipping from our factory. Change it to the desired position in accordance with your facility.

Operating Range

Unit: mm

Auto switch model	Bore size		
	40	50	63
D-P3DWA□	6	5.5	6
D-P4DW□	4	4	4.5
D-P79WSE	8	9	9.5
D-P74□			
D-M9□	4	4.5	5
D-A9□	8	8	9

* Since this is a guideline including hysteresis, not meant to be guaranteed. (Assuming approximately $\pm 30\%$ dispersion.)

There may be the case it will vary substantially depending on an ambient environment.

Auto Switch Mounting Bracket / Part No.

Switch mounting rod assembly / Auto switch mounting bracket assembly

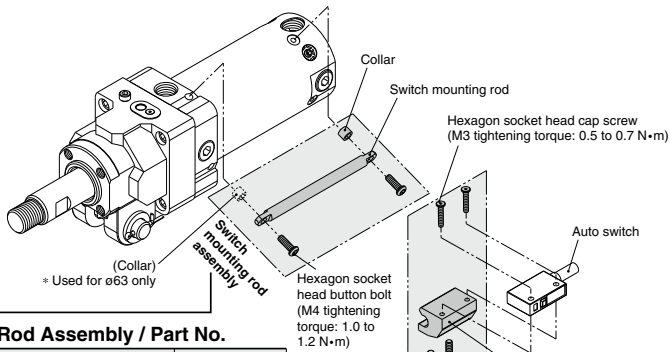

Switch Mounting Rod Assembly / Part No.

Applicable series	Applicable clamp cylinder	Part no.
Dedicated to CLK2G□40 series	CLK2G□40-50	CLKG40-R050
	CLK2G□40-75	CLKG40-R075
	CLK2G□40-100	CLKG40-R100
	CLK2G□40-125	CLKG40-R125
	CLK2G□40-150	CLKG40-R150
Dedicated to CLK2P□40 series	CLK2P□40-50	CLKP40-R050
	CLK2P□40-75	CLKP40-R075
	CLK2P□40-100	CLKP40-R100
	CLK2P□40-125	CLKP40-R125
	CLK2P□40-150	CLKP40-R150
CLK2G□50 series	CLK2G□50-50/CLK2P□50-50	CLKG50-R050
	CLK2G□50-75/CLK2P□50-75	CLKG50-R075
CLK2P□50 series	CLK2G□50-100/CLK2P□50-100	CLKG50-R100
	CLK2G□50-125/CLK2P□50-125	CLKG50-R125
Common	CLK2G□50-150/CLK2P□50-150	CLKG50-R150
CLK2G□63 series	CLK2G□63-50/CLK2P□63-50	CKG40-R050
	CLK2G□63-75/CLK2P□63-75	CKG40-R075
CLK2P□63 series	CLK2G□63-100/CLK2P□63-100	CKG40-R100
	CLK2G□63-125/CLK2P□63-125	CKG40-R125
Common	CLK2G□63-150/CLK2P□63-150	CKG40-R150

Hexagon socket head cap screw (M4 tightening torque: 1.0 to 1.2 N·m)

Auto switch mounting bracket

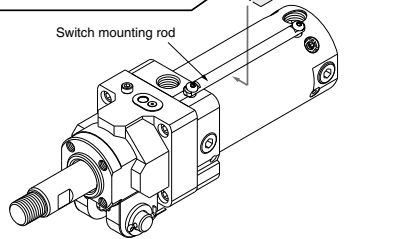
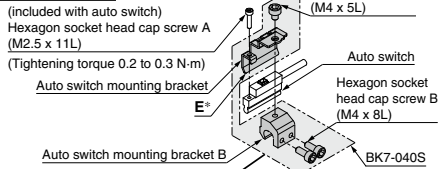

Auto Switch Mounting Bracket Assembly / Part No.

Applicable cylinder series	Applicable auto switch	Auto switch mounting bracket part no.		
		40	50	63
CLK2G series	D-P3DWA□		BK7-040S	
	D-P4DW□		BK1T-040	
	D-M9□ D-A9□		BA7-040	
CLK2P series	D-P79WSE D-P74LUZ		BAP1T-040	

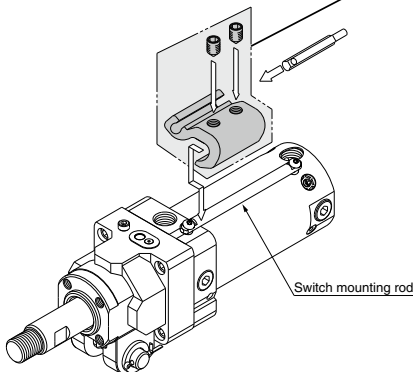

CLK2 Series

Auto Switch Mounting (Band Mounting Type)

Auto Switch Proper Mounting Position (Detection at Stroke End) and Its Mounting Height

Band mounting D-P4DW□ type

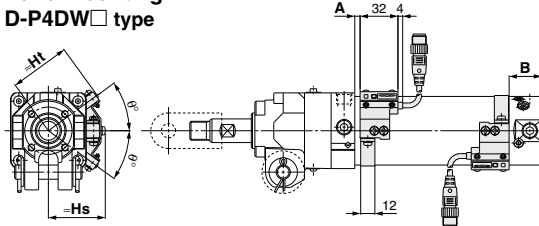

Note) The above drawing is the auto switch band mounting example for the D-P4DWS□ type.

D-A9□/M9□ (W) type

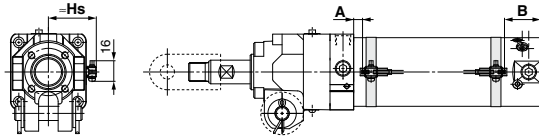

D-B54 type

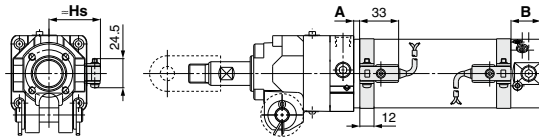

Auto Switch Mounting Position and Its Height: Band Mounting

Unit: mm

Auto switch model	Symbol	Auto switch set value and its height			
		32	40	50	63
D-P4DW□	A	0	8	4.5	4.5
	B	27.5	20.5	27.5	27.5
	Hs	38	43	48	55
	Ht	41.5	46	51.5	58.5
	θ	45°	40°	36°	33°
D-M9□	A	7	15	11.5	11.5
D-M9□W	B	34.5	27.5	34.5	34.5
D-M9□A	Hs	30	34.5	40	47
D-A9□	A	3	11	7.5	7.5
	B	30.5	23.5	30.5	30.5
	Hs	30	34.5	40	47
D-B54	A	0	5.5	2	2
	B	25	18	25	25
	Hs	33.5	38	43.5	50.5

Note 1) The mounting position should be referred for reference only for the auto switch mounting position at the stroke end detection. Adjust the auto switch after confirming the operation to set actually.

Note 2) A/B dimensions are the distance from the standard position (above drawing) to the end surface of the auto switch.

Note 3) As for the D-P4DW type, band mounting type, the auto switch mounting bracket and the auto switch have to be ordered separately. For details, refer to page 470.

Operating Range

Unit: mm

Auto switch model	Bore size			
	32	40	50	63
D-P4DW□	4.5	5	5	5.5
D-M9□	4	3.5	4	4
D-M9□W	5	5.5	6.5	7
D-M9□A	5	5.5	6.5	7
D-A9□	8	8	8	9
D-B54	9	10	10	11

* Since this is a guideline including hysteresis, not meant to be guaranteed.
(Assuming approximately ±30% dispersion.) There may be the case it will vary substantially depending on an ambient environment.

Auto Switch Mounting Brackets/Part No.

Auto switch model	Bore size (mm)			
	32	40	50	63
D-P4DW □	BA8-032	BA8-040	BA8-050	BA8-063

Auto switch mounting bracket B

Auto switch mounting bracket D

Cross recessed round head screw (M4 tightening torque: 1.0 to 1.2)

Cross recessed round head screw (M4 tightening torque: 1.0 to 1.2 N-m)

Spring washer

D-P4DW□ auto switch

Cross recessed round head screw (M3 tightening torque: 0.5 to 0.7 N-m)

Auto switch mounting band

Auto switch model	Bore size (mm)			
	32	40	50	63
D-M9 □ D-M9 □W D-A9 □	BMA3-032 <small>Note 1)</small> (A set of a, b, c, d)	BMA3-040 <small>Note 1)</small> (A set of a, b, c, d)	BMA3-050 <small>Note 1)</small> (A set of a, b, c, d)	BMA3-063 <small>Note 1)</small> (A set of a, b, c, d)
D-M9 □A <small>Note 2)</small>	BMA3-032S (A set of b, c, e, f)	BMA3-040S (A set of b, c, e, f)	BMA3-050S (A set of b, c, e, f)	BMA3-063S (A set of b, c, e, f)

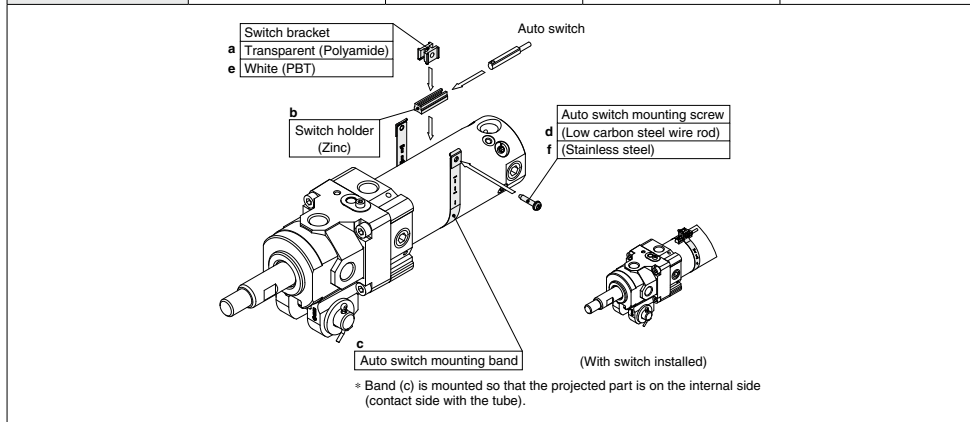

D-B54	BA-32 (A set of band and screw)	BA-04 (A set of band and screw)	BA-05 (A set of band and screw)	BA-06 (A set of band and screw)
--------------	------------------------------------	------------------------------------	------------------------------------	------------------------------------

Note 1) As the switch bracket is made of polyamide, its performance may be affected by chemicals such as alcohol, chloroform, methylamines, hydrochloric acid, and sulfuric acid, so it cannot be used in environments where these chemicals come into contact with the product.

Note 2) When mounting a D-M9□A(V) type auto switch, if the switch bracket is mounted on the indicator light, it may damage the auto switch. Therefore, be sure to avoid mounting the switch bracket on the indicator light.



1 Unlock-port Separate Piping Type

3-position valves (closed center) can be used by piping the unlock-port separately.

CLK2 G A **50** - **100** **Y** - **B** **2** **L** - **P3DWASC** - **X1604**

Built-in standard magnet type

	Clevis width	Bore size
A	16.5 mm ø40, ø50, ø63	40 40 mm
B	19.5 mm ø50, ø63	50 50 mm
C	12.5 mm ø40, ø50, ø63	63 63 mm

Clevis width

Bore size

Cylinder stroke
50, 75, 100, 125, 150

End bracket

Symbol	Description
Nil	None
Y	Double knuckle joint (M6 without tap)
YA	Double knuckle joint (M6 with tap)

Note) Pin (for knuckle), cotter pin and flat washer are provided as a standard for Y and YA.

Unlock-port separate piping

Number of auto switches

Symbol	Description
Nil	2 pcs.
S	1 pc.
n	"n" pcs. (n = 3, 4, 5...n)

Auto switch

Auto switch model	Description
Nil	Without auto switch, Without switch mounting rod
P	Without auto switch, With switch mounting rod
Auto switch model	With auto switch, With switch mounting rod

Switch mounting rod position

Symbol	Description
Nil	Top
L	Left
R	Right

Locking direction

Symbol	Description
B	Retraction locking
F	Extension locking

Unlock-port position

Symbol	Position (Viewed from rod side)	Locking direction	
		Retraction locking	Extension locking
Nil	Top	—	○
2	Left	○	○
3	Right	○	○

SMC Original Symbol

Retraction locking type

Extension locking type

Note 1) Unlock-port cannot be placed on the top of the cylinder when the retraction locking type is selected.
Note 2) The cylinder actuating port is mounted on the top of the cylinder at the time of shipment from the factory.
Although the position of the cylinder actuating port can be changed from [top] to [left or right] in the extension locking type by changing the plug position, it cannot be changed from [top] in the retraction locking type.

Applicable Magnetic Field Resistant Auto Switches (Refer to pages 1341 to 1435 for detailed auto switch specifications.)

Applicable cylinder series	Type	Auto switch model	Applicable magnetic field	Electrical entry	Indicator light	Wiring (Pin no. in use)	Load voltage	Lead wire length	Applicable load			
CLK2G series	Solid state auto switch	D-P3DWASC	AC magnetic field (Single-phase AC welding magnetic field)	Pre-wired connector	2-color display	2-wire (3-4)	24 VDC	0.3 m	Relay, PLC			
		D-P3DWASE				2-wire (1-4)				0.5 m		
		D-P3DWA				2-wire		3 m				
		D-P3DWAL								2-wire (3-4)	5 m	
		D-P3DWAZ		2-wire (1-4)		0.3 m						
		D-P4DWSC						Pre-wired connector		2-wire	3 m	
		D-P4DWSE		Grommet		5 m						
		D-P4DWL										2-wire
		D-P4DWZ			2-wire							

Note 1) Refer to page 481 when ordering the auto switch mounting bracket assembly or switch mounting rod assembly.

Note 2) For D-P3DWAL□, auto switches and auto switch mounting brackets are shipped together (not assembled).

Dimensions: CLK2GA40/50/63-X1604

Retraction locking (B)

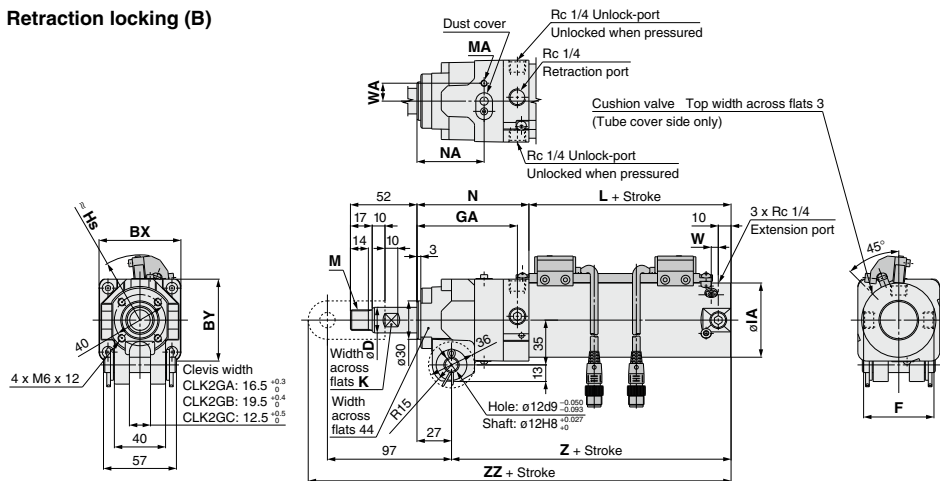

Symbol	BX	BY	D	F	GA	IA	K	L	M	MA	N	NA	W	WA	Z	ZZ	Hs
40	56	54	16	44	77	47	14	55	M12 x 1.5	M4 x 7	86	51.5	5	12.5	114	226	45.5
50	64	64	20	55	78.5	58	17	58	M16 x 1.5	M4 x 7	87.5	52.5	5.5	14	118.5	230.5	51
63	74	74	20	69	82	72	17	58	M16 x 1.5	M5 x 7	91	53.5	5.5	19	122	234	58.5

Extension locking (F)

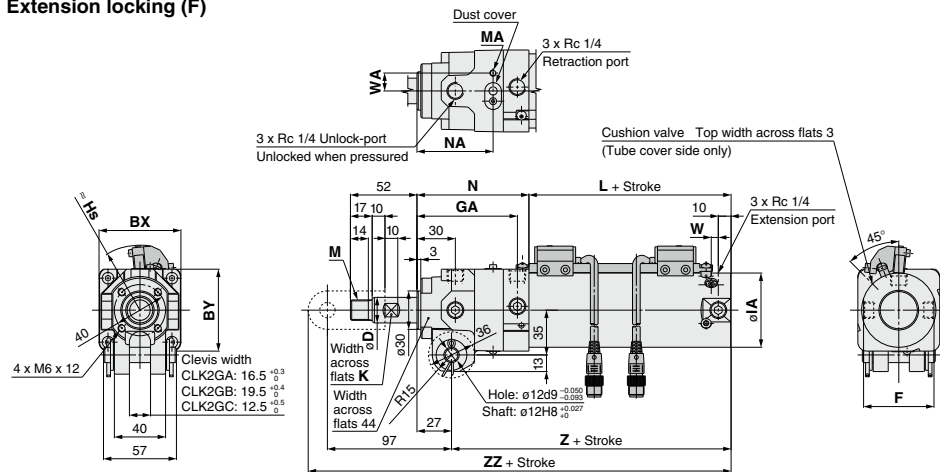

Symbol	BX	BY	D	F	GA	IA	K	L	M	MA	N	NA	T	W	WA	Z	ZZ	Hs
40	56	54	16	44	77	47	14	55	M12 x 1.5	M4 x 7	86	59	57	5	12.5	114	226	45.5
50	64	64	20	55	78.5	58	17	58	M16 x 1.5	M4 x 7	87.5	59.5	60	5.5	14	118.5	230.5	51
63	74	74	20	69	82	72	17	58	M16 x 1.5	M5 x 7	91	61	67	5.5	19	122	234	58.5



CLK2 Series Specific Product Precautions 1

Be sure to read this before handling the products.
Refer to page 9 for safety instructions and pages 10 to 19 for actuator and auto switch precautions.

Cushion Adjustment

Cushion Adjustment

The CLK2 series has an integrated air cushion in the head end. The cushion is pre-adjusted at the time of shipping. However, please re-adjust the cushion valve in the tube cover, depending on operating speed and load before use.

The diameter of throttle will be smaller when the cushion valve is turned clockwise, resulting in stronger cushion reaction.

Shown below is the fully opened state, although the cushion valve can rotate 360 degrees.

The adjustment range is about 225 degrees from the fully opened state. The range between 225 and 360 degrees is the fully closed state.

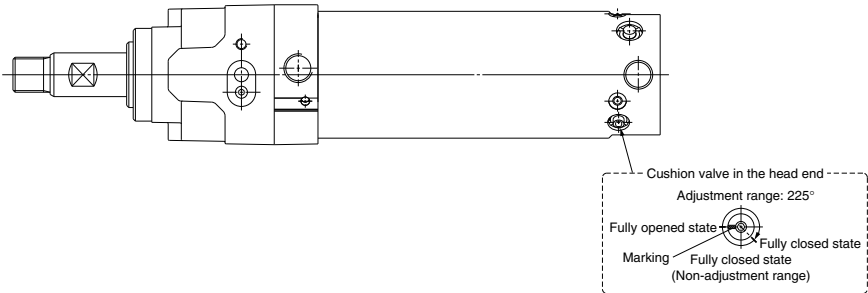



CLK2 Series Specific Product Precautions 2

Be sure to read this before handling the products.
Refer to page 9 for safety instructions and pages 10 to 19 for actuator and auto switch precautions.

Selection

Warning

1. Since the holding force (max. static load) indicates a cylinder's ability to hold a static load without being affected by vibration or impact, max. load (workpiece mass) should be 50% or less of the holding force (max. static force).

2. Do not perform intermediate stops while the cylinder is operating.

This cylinder is designed to lock inadvertent movement in the static condition. If the locking mechanism is used to stop the cylinder at an intermediate position during operation, the cylinder or unlocking mechanism may fail or the product's service life may be significantly shortened.

3. Select the correct locking position, as this cylinder does not generate holding force opposite to the locking direction.

The extension locking type does not generate holding force in the cylinder's retracting direction, and the retraction locking type does not generate holding force in the cylinder's extending direction.

4. Even when locked, there may be stroke movement of maximum 1 mm in the locking direction due to external forces such as the weight of the work piece.

Even when locked, if air pressure drops, stroke movement of maximum 1 mm may be generated in the locking direction of the lock mechanism due to external forces such as the work piece weight.

5. When locked, do not apply impact loads, strong vibration or rotational force, etc.

This will lead to lock mechanism damage, reduced service life, malfunction of unlocked condition etc.

Preparing for Operation

Warning

1. When shipped from the factory, an unlocked condition is maintained by the unlocking bolt. Be sure to remove this bolt before operating. (The unlocking bolt can be stored in tap A after it is removed.)

Since the unlocking bolt is required to maintain the unlocked condition during maintenance, pay attention not to lose it.

Step 1) With no air pressure in the cylinder, retraction locking operates when the piston rod is retracted, and extension locking operates when it is extended.

Step 2) Remove the dust proof cover 1.

Step 3) Supply air pressure of 0.2 MPa or more to port 2 in the figure below.

Step 4) Remove the unlocking bolt 3 using a hexagon wrench.

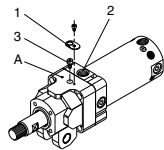

Retraction locking type

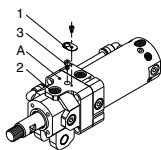

Extension locking type

Preparing for Operation

Warning

2. Adjust the speed controller and the retraction side air cushion.

If there is excessive impact or collision noise at the stroke end, the connection may become loose and cause damage to machinery.

3. Before restarting operation from the locked position, be sure to restore air pressure to the B port in the figure below.

It is very dangerous to apply pressure to the A port with the B port in an unpressurized state, because the cylinder will move suddenly when unlocked.

This may damage the locking mechanism, shorten the service life or cause unlocking malfunction.

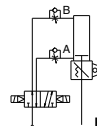

Retraction locking type

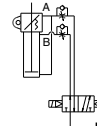

Extension locking type

* The symbol for the cylinder with lock in the pneumatic circuit uses SMC original symbol.

Pneumatic Circuits

Warning

1. Do not use 3 position valves.

The lock may be released due to the inflow of the unlocking pressure. When 3-position valves are used, please use the unlock-port separate-piping type (-X1604) shown on pages 484 and 485.

2. Install speed controllers for meter-out control.

Malfunction may occur if meter-in control is used or speed controllers are not used.

3. Be careful of reverse exhaust pressure flow from a common exhaust type manifold.

Since the lock may be released due to reverse exhaust pressure flow, use an individual exhaust type manifold or single type valve.

4. Be aware that the dew condensation caused by the repeated air supply and exhaust may occur when installing the solenoid valve for locking, such as unlock-port separate piping type (-X1604).

The operating stroke of the lock part is very small. So, if the piping is long and the air supply and exhaust are repeated, the dew condensation caused by the adiabatic expansion accumulates in the lock part. This may corrode internal parts, causing air leak or lock release fault.

Mounting

Caution

1. Be sure to connect the load to the rod end with the cylinder in an unlocked condition.

If this is done when in a locked condition, it may cause damage to the lock mechanism.



CLK2 Series

Specific Product Precautions 3

Be sure to read this before handling the products.
Refer to page 9 for safety instructions and pages 10 to 19 for actuator and auto switch precautions.

Unlocking

Warning

Maintaining an Unlocked Condition

1. To maintain an unlocked condition, be sure to follow the steps shown below.

- 1) After carefully confirming safety, operate a switching valve (solenoid valve, etc.) so that retraction locking operates when the piston rod is retracted, and extension locking operates when it is extended. Furthermore, air pressure of 0.2 MPa or more is required when this is done.
- 2) Remove the dust proof cover.
- 3) Screw in the accessory unlocking bolt (hexagon socket headcap screw $\phi 32$: M3 x 5 L, $\phi 40$: M4 x 6 L, $\phi 50$: M4 x 6 L, $\phi 63$: M5 x 6 L).

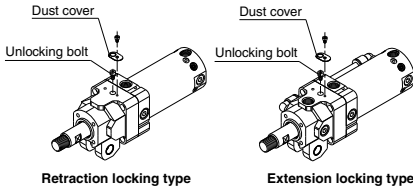

2. When the locking mechanism is to be used again, be sure to remove the unlocking bolt.

The locking mechanism will not work when the unlocking bolt is screwed in. Remove the unlocking bolt following the steps shown in the section on preparing for operation.

Manually Unlocking

1. Do not perform unlocking while an external force such as a load or spring force is being applied.

This is very dangerous because the cylinder will move suddenly. Release the lock after preventing cylinder movement with a lifting device such as a jack.

2. After confirming safety, operate the manual release following the steps shown below.

Confirm that there are no personnel inside the load movement range, etc., and that there is no danger even if the load moves suddenly.

Manually unlocking

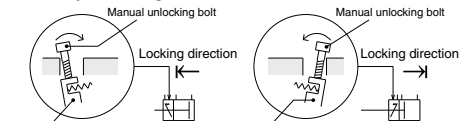

Extension locking

- 1) Remove the dust cover.
 - 2) Screw a manual unlocking bolt into the lock ring threads as shown above, and lightly push the bolt in the direction of the arrow (head side) to unlock.
- For the bolts, use commercially-available bolts of the sizes below
 $\phi 32$: M3 x 20 L
 $\phi 40$, $\phi 50$: M4 x 30 L
 $\phi 63$: M5 x 30 L

Retraction locking

- 1) Remove the dust cover.
 - 2) Screw a manual unlocking bolt into the lock ring threads as shown above, and lightly push the bolt in the direction of the arrow (rod side) to unlock.
- For the bolts, use commercially-available bolts of the sizes below
 $\phi 32$: M3 x 20 L
 $\phi 40$, $\phi 50$: M4 x 30 L
 $\phi 63$: M5 x 30 L

Maintenance

Caution

1. In order to maintain good performance, use with clean unlubricated air.

If lubricated air, compressor oil or drainage, etc., enters the cylinder, there is a danger of sharply reducing the locking performance.

2. Do not apply grease to the piston rod.

There is a danger of sharply reducing the locking performance.

3. Never disassemble the lock unit.

It contains a heavy duty spring which is dangerous. There is also a danger of reducing the locking performance.

Piping Port / Switch Mounting Rod (bypass piping) Position Change

Warning

1. Piping port position, switch mounting rod position, and bypass piping position can be selected by the part number. However, if there is an error in ordering and changes to the positions are required, please note the following.

- 1) Move all the parts that are aligned in a straight line in the stroke direction by 90° or 180° around the circumference of the cylinder.
Never move parts in the stroke direction, as this will cause malfunction.
- 2) Do not operate with any parts removed. When the cylinder is operated with any part removed, malfunction will occur and it is very dangerous.
- 3) Although fittings with sealant are used for pipe fittings and plugs, wind them with pipe tape to prevent air leakage when reassembling after position changes.

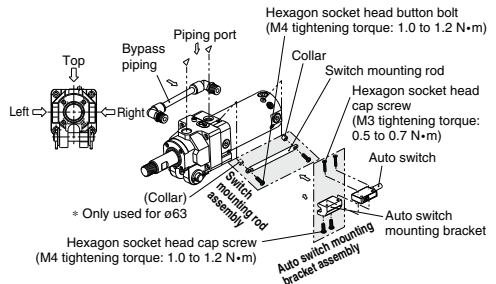



CLK2 Series

Specific Product Precautions 4

Be sure to read this before handling the products.
Refer to page 9 for safety instructions and pages 10 to 19 for actuator and auto switch precautions.

Handling

Magnetic field resistant auto switches D-P79WSE/D-P74□ type are specifically for use with magnetic field resistant cylinders and are not compatible with general auto switches or cylinders. Magnetic field resistant cylinders are labeled as follows.

Magnetic field resistant cylinder with built-in magnet
(For use with auto switch D-P7 type)

Mounting

- The minimum stroke for mounting magnetic field resistant auto switches is 50 mm.**
- In order to fully use the capacity of magnetic field resistant auto switches, strictly observe the following precautions.**
 - Do not allow the magnetic field to occur when the cylinder piston is moving.
 - When a welding cable or welding gun electrodes are near the cylinder, change the auto switch position to fall within the operational ranges shown in the graphs on page 490, or move the welding cable away from the cylinder.
 - Cannot be used in an environment where welding cables surround the cylinder.
 - If multiple objects that generate a magnetic field (such as a welding cable and a welding gun electrode) move close to an auto switch, the closest they are allowed to be to the auto switch can be calculated by multiplying the safety distance by the number of elements.
- In an environment where spatter directly hits the lead wire, cover the lead wire with protective tubing. Use protective tubing with a bore size of $\varnothing 8$ or more that has excellent heat resistance and flexibility.**
- Be careful not to drop objects, make dents, or apply excessive impact force when handling.**
- When built-in strong magnet type cylinders are closely positioned to each other, please pay attention to the following items.**
 - When more than 2 pcs. cylinders with general purpose auto switches are juxtaposed, leave the distance of 40 mm or more between the cylinder tubes.
 - Separate a reed magnetic field resistant auto switch from the tube surface of a closely mounted built-in strong magnet type cylinder by 30 mm or more.
 - When a built-in strong magnet type cylinder and a cylinder with a general-purpose auto switch are closely positioned, separate the cylinder tubes 50 mm or more.
 - Separate a general-purpose auto switch from the tube surface of a closely mounted built-in strong magnet cylinder by 50 mm or more away.
- Avoid wiring in a manner in which repeated bending stress or tension is applied to lead wires.**
- Do not use this product in environments with constant water and coolant splashing.**
- Please be careful of the mounting direction of the magnetic field resistant auto switch D-P79WSE type. Be sure to face the molded surface with soft-resin to the auto switch mounting bracket side for mounting.**
(Please refer to page 480 for mounting example and page 1430 for soft-resin mold surface.)

Wiring/Current and Voltage

- Always connect the auto switch to the power supply after the load has been connected.**
- Series connection**
When auto switches are connected in series as shown below:

Note that the voltage drop due to the internal resistance of the LED increases.

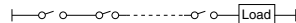



CLK2 Series Specific Product Precautions 5

Be sure to read this before handling the products.
Refer to page 9 for safety instructions and pages 10 to 19 for actuator
and auto switch precautions.

Data: Magnetic Field Resistant Reed Switch (D-P79WSE type, D-P74□ type) Safety Distance

Safety Distance from Side of Auto Switch

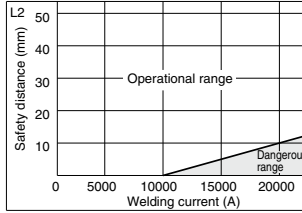
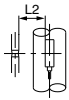
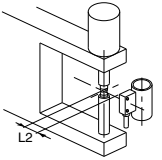
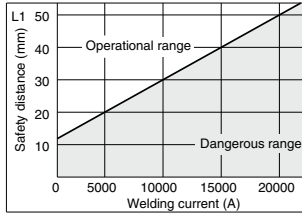
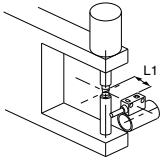

Safety Distance from Top of Auto Switch

