

Tamper Proof Speed Controller with One-touch Fitting

Series AS□□□1F-T Elbow Type/Universal Type

Able to adjust flow by a special tool

Prevention of an unnecessary manual operation

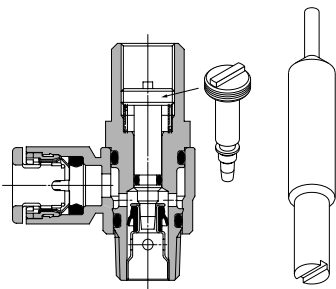

Special tool
Part number: AS-T-1

Specifications

| | |
|---|------------------------------------|
| Fluid | Air |
| Proof pressure | 1.5 MPa |
| Max. operating pressure | 1 MPa |
| Min. operating pressure | 0.1 MPa |
| Ambient and fluid temperature | -5 to 60°C (No freezing) |
| Number of needle rotations | 10 turns (8 turns ⁽¹⁾) |
| Applicable tubing material ⁽²⁾ | Nylon, Soft nylon, Polyurethane |

Note 1) In the case of AS12□1F-M5 and AS12□1F-U10/32 types
AS13□1F-M5, AS13□1F-U10/32

Note 2) Use caution regarding the max. operating pressure when soft nylon or polyurethane tubing is used.
(Refer to pages 15-6-3 to 15-6-5 for details.)

Note 3) Brass parts are all electroless nickel plated, provided as standard.

Model

| Elbow type | Universal type | Port size | Applicable tubing O.D. | | | | | | | | | | | | Applicable cylinder bore size (mm) | | |
|----------------|----------------|-----------|------------------------|---|---|---|----|----|-----------|-------|-------|------|-------|------|------------------------------------|------|----------------|
| | | | Metric size | | | | | | Inch size | | | | | | | | |
| | | | 3.2 | 4 | 6 | 8 | 10 | 12 | 1/8" | 5/32" | 3/16" | 1/4" | 5/16" | 3/8" | | 1/2" | |
| AS12□1F-M5 | AS13□1F-M5 | M5 x 0.8 | ● | ● | ● | | | | | | | | | | | | 6, 10, 16, 20 |
| AS22□1F-01 | AS23□1F-01 | R 1/8 | ● | ● | ● | ● | ● | | | | | | | | | | 20, 25, 32 |
| AS22□1F-02 | AS23□1F-02 | R 1/4 | | ● | ● | ● | ● | | | | | | | | | | 20, 25, 32, 40 |
| AS32□1F-02 | AS33□1F-02 | R 1/4 | | | ● | ● | ● | ● | | | | | | | | | 40, 50, 63 |
| AS32□1F-03 | AS33□1F-03 | R 3/8 | | | ● | ● | ● | ● | | | | | | | | | 40, 50, 63 |
| AS42□1F-04 | AS43□1F-04 | R 1/2 | | | | | ● | ● | | | | | | | | | 63, 80, 100 |
| AS12□1F-U10/32 | AS13□1F-U10/32 | 10-32 UNF | | | | | | | | ● | ● | ● | ● | | | | 6, 10, 16, 20 |
| AS22□1F-N01 | AS23□1F-N01 | NPT 1/8 | | | | | | | | ● | ● | ● | ● | ● | | | 20, 25, 32 |
| AS22□1F-N02 | AS23□1F-N02 | NPT 1/4 | | | | | | | | | ● | ● | ● | ● | ● | | 20, 25, 32, 40 |
| AS32□1F-N02 | AS33□1F-N02 | NPT 1/4 | | | | | | | | | | ● | ● | ● | | | 40, 50, 63 |
| AS32□1F-N03 | AS33□1F-N03 | NPT 3/8 | | | | | | | | | | | ● | ● | ● | | 40, 50, 63 |
| AS42□1F-N04 | AS43□1F-N04 | NPT 1/2 | | | | | | | | | | | | | ● | ● | 63, 80, 100 |

Note 1) * Elbow type only

Note 2) Meter-out and meter-in types can be visually differentiated by the flow direction symbol on the resin body.

Elbow type



Universal type



How to Order

AS 2 2 1 1 F - 01 - 06 S T

Body size

| | |
|---|-------------------|
| 1 | M5 standard |
| 2 | 1/8, 1/4 standard |
| 3 | 3/8 standard |
| 4 | 1/2 standard |

Type

| | |
|---|-----------|
| 2 | Elbow |
| 3 | Universal |

Control

| | |
|---|-----------|
| 0 | Meter-out |
| 1 | Meter-in |

With One-touch fitting

Port size

| | |
|--------|-----------|
| M5 | M5 x 0.8 |
| 01 | R 1/8 |
| 02 | R 1/4 |
| 03 | R 3/8 |
| 04 | R 1/2 |
| U10/32 | 10-32 UNF |
| N01 | NPT 1/8 |
| N02 | NPT 1/4 |
| N03 | NPT 3/8 |
| N04 | NPT 1/2 |

Tamper proof

Speed Controller requires a special tool for flow adjustment. Order separately with part number, AS-T-1.

With seal

Note) In case that connecting port is either M5 or 10-32 UNF thread, it is not available with seal. With gasket is provided as standard.

Applicable tubing O.D.

| Metric size | Inch size |
|-------------|-----------|
| 23 | ø3.2" |
| 04 | ø4 |
| 06 | ø6 |
| 08 | ø8 |
| 10 | ø10 |
| 12 | ø12 |
| 01 | ø1/8" |
| 03 | ø5/32" |
| 05 | ø3/16" |
| 07 | ø1/4" |
| 09 | ø5/16" |
| 11 | ø3/8" |
| 13 | ø1/2" |

* Use ø1/8" tube.

Tamper Proof Speed Controller With One-touch Fitting, Elbow Type/Universal Type

Needle Valve/Flow Characteristics

AS12□1F
AS13□1F

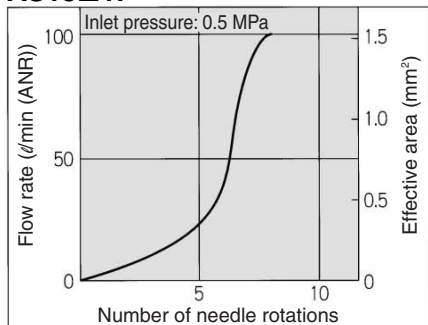

AS22□1F-□01
AS23□1F-□01

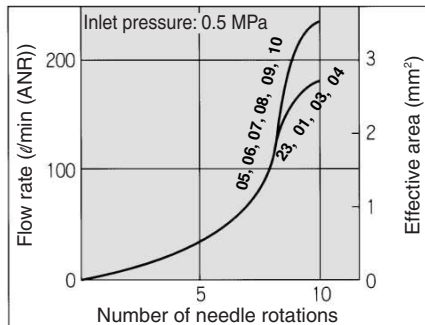

AS22□1F-□02
AS23□1F-□02

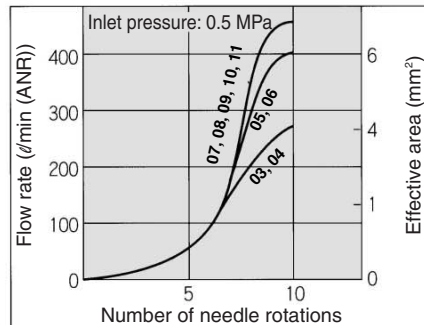

AS32□1F
AS33□1F

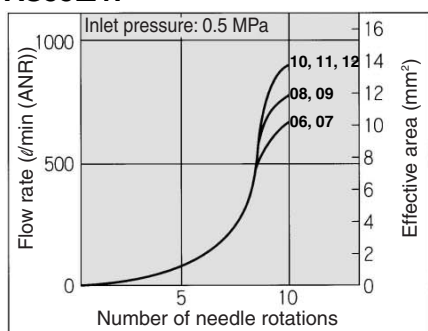

AS42□1F
AS43□1F

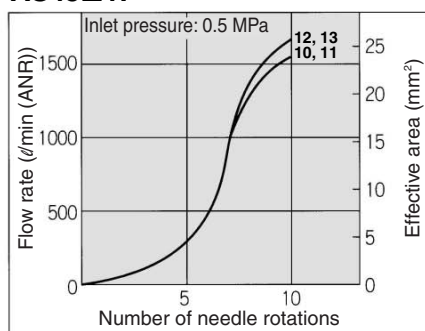

JIS Symbol

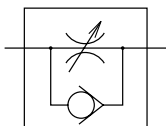

Flow Direction Symbols on Body

| | Meter-out type | Meter-in type |
|------------|----------------|---------------|
| Symbol | | |
| JIS Symbol | | |

- AS
- ASP
- ASN
- AQ
- ASV
- AK
- ASS
- ASR
- ASF

Flow Rate and Effective Area

| Model | | AS12□1F AS13□1F | AS22□1F-□01 AS23□1F-□01 | AS22□1F-□02 AS23□1F-□02 | AS32□1F AS33□1F | AS42□1F AS43□1F | | | | | | |
|--------------------------------|-------------------------|--------------------------------|--|--|--------------------------|--------------------|-----|-----|-----|-----|------|------|
| Tubing O.D. | Metric size | ø3.2, ø4, ø6 | ø3.2, ø4 ø6, ø8, ø10 | ø4 ø6 ø8, ø10 | ø6 ø8 ø10, ø12 | ø10 ø12 | | | | | | |
| | Inch size | ø1/8", ø5/32" ø3/16", ø1/4" | ø1/8" ø5/32" ø3/16", ø1/4" ø5/16" | ø5/32" ø3/16" ø1/4", ø5/16" ø3/8" | ø1/4" ø5/16" ø3/8" | ø3/8" ø1/2" | | | | | | |
| Controlled flow (Free flow) | Flow rate (l/min (ANR)) | 100 | 180 | 230 | 260 | 390 | 460 | 660 | 790 | 920 | 1580 | 1710 |
| | Effective area (mm²) | 1.5 | 2.7 | 3.5 | 4 | 6 | 7 | 10 | 12 | 14 | 24 | 26 |

(Note) Flow rate values are at a pressure of 0.5 MPa and a temperature of 20°C.

Construction

**Elbow type
Meter-out type**

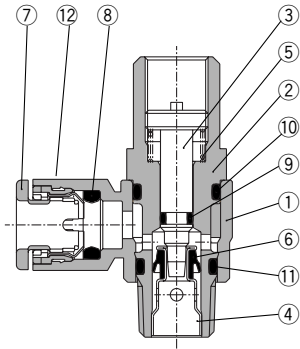

**M5 type
U10/32 type**

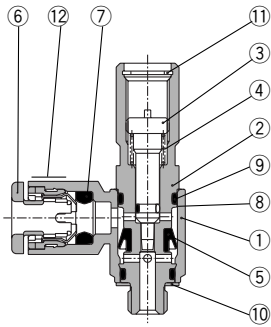

Meter-in type

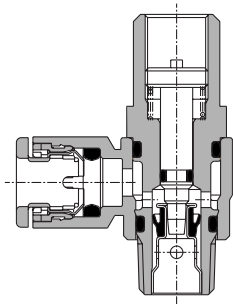

**M5 type
U10/32 type**

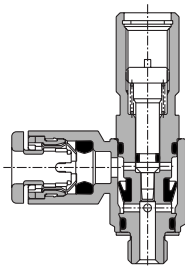

**Universal type
Meter-out type**

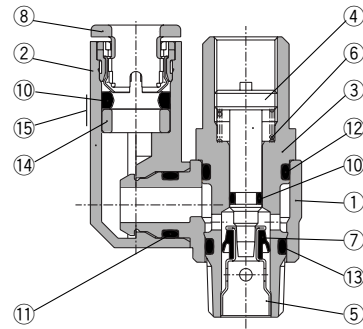

**M5 type
U10/32 type**

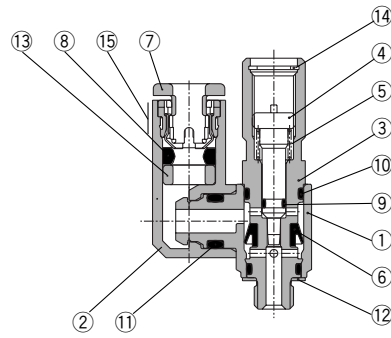

Meter-in type

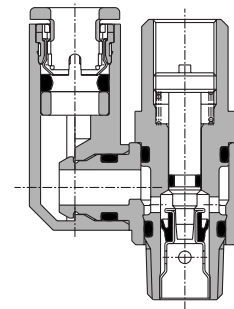

**M5 type
U10/32 type**

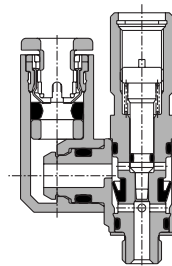

Tamper Proof Speed Controller

With One-touch Fitting, Elbow Type/Universal Type

Construction

Elbow type Meter-out type

AS3201F-02

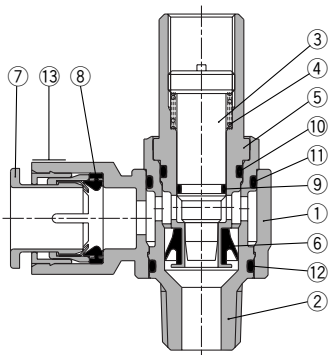

Meter-in type

AS3211F-02

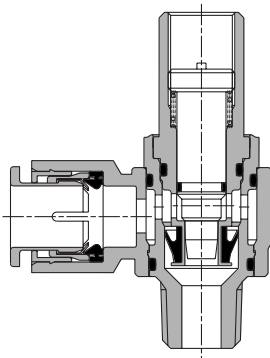

Component Parts

| No. | Description | Material | Note |
|-----|--------------------------------|-----------------------------|---------------------------|
| ① | Body A | PBT | |
| ② | Body B | Brass | Electroless nickel plated |
| ③ | Needle | Brass | Electroless nickel plated |
| ④ | Seat ring | Brass | Electroless nickel plated |
| ⑤ | Spring | Steel wire | |
| ⑥ | U seal | HNBR | |
| ⑦ | Cassette | POM, Stainless steel (Note) | |
| ⑧ | Seal | NBR | |
| ⑨ | O-ring | NBR | |
| ⑩ | O-ring | NBR | |
| ⑪ | O-ring | NBR | |
| ⑫ | O-ring | NBR | |
| ⑬ | Gasket | NBR, Stainless steel | |
| ⑭ | Retaining ring for hole type C | Tool steel | |

Note) $\phi 10$, $\phi 12$, $\phi 3/8$ ", $\phi 1/2$ " are made of POM, stainless steel, and brass (Electroless nickel plated).

Universal type Meter-out type

AS3301F-02

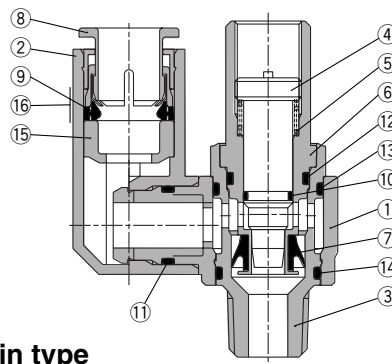

Meter-in type

AS3311F-02

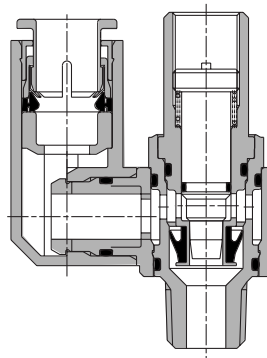

Component Parts

| No. | Description | Material | Note |
|-----|--------------------------------|--------------------------|---------------------------|
| ① | Body A | PBT | |
| ② | Elbow body | PBT | |
| ③ | Body B | Brass | Electroless nickel plated |
| ④ | Needle | Brass | Electroless nickel plated |
| ⑤ | Seat ring | Brass | Electroless nickel plated |
| ⑥ | Spring | Steel wire | |
| ⑦ | U seal | HNBR | |
| ⑧ | Cassette | POM, Stainless steel (1) | |
| ⑨ | Seal | NBR | |
| ⑩ | O-ring | NBR | |
| ⑪ | O-ring | NBR | |
| ⑫ | O-ring | NBR | |
| ⑬ | O-ring | NBR | |
| ⑭ | O-ring | NBR | |
| ⑮ | Spacer | POM (2) | |
| ⑯ | Gasket | NBR, Stainless steel | |
| ⑰ | Retaining ring for hole type C | Tool steel | |

Note 1) $\phi 3/16$ ", $\phi 5/16$ ", $\phi 3/8$ ", $\phi 1/2$ " are made of POM, stainless steel, brass (Electroless nickel plated).

Note 2) $\phi 3/16$ ", $\phi 3/8$ ", $\phi 1/2$ " are made of brass (Electroless nickel plated).

- AS
- ASP
- ASN
- AQ
- ASV
- AK
- ASS
- ASR
- ASF

Dimensions

Elbow type

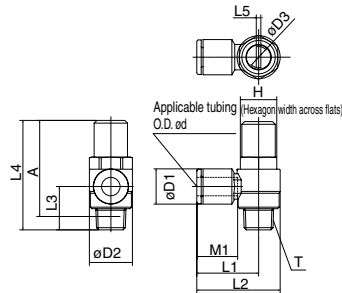

Metric Size

| Model | d | T | H | D1 | D2 | D3 | L1 | L2 | L3 | L4 | L5 | A* | M1 | | | | |
|-----------------|-----|----------|----|------|------|-----|------|------|------|------|-----|------|------|------|------|------|------|
| AS12□1F-M5-23T | 3.2 | M5 x 0.8 | 8 | 8.4 | 9.6 | 4.5 | 17.3 | 22.1 | 12.3 | 31 | 0.7 | 27.4 | 12.7 | | | | |
| AS12□1F-M5-04T | 4 | | | 9.3 | | | 20.4 | 27.5 | 12.7 | | | | | | | | |
| AS12□1F-M5-06T | 6 | | | 11.6 | | | 18.1 | 22.9 | 11.7 | | | | | 13.5 | | | |
| AS22□1F-01-23ST | 3.2 | R 1/8 | 12 | 8.4 | 14.2 | 7 | 20.4 | 27.5 | 14.3 | 35.6 | 1.5 | 31.6 | 12.7 | | | | |
| AS22□1F-01-04ST | 4 | | | 9.3 | | | | | | | | | | 25.3 | 32.4 | 18.5 | |
| AS22□1F-01-06ST | 6 | | | 11.6 | | | | | | | | | | 33.1 | 40.2 | 15 | 21 |
| AS22□1F-01-08ST | 8 | R 1/4 | 17 | 12.8 | 18.5 | 7 | 25.2 | 34.4 | 18.2 | 40.7 | 1.5 | 34.7 | 17 | | | | |
| AS22□1F-01-10ST | 10 | | | 15.2 | | | | | | | | | | 33.9 | 43.2 | 20 | 21 |
| AS22□1F-02-04ST | 4 | | | 10.4 | | | | | | | | | | 27.8 | 39.3 | 17 | 16 |
| AS22□1F-02-06ST | 6 | R 1/4 | 19 | 12.8 | 23 | 9.5 | 29.5 | 41 | 21.8 | 55.3 | 1.5 | 49.3 | 18.5 | | | | |
| AS22□1F-02-08ST | 8 | | | 15.2 | | | | | | | | | | 31.8 | 43.3 | 21 | 17 |
| AS22□1F-02-10ST | 10 | | | 18.5 | | | | | | | | | | 33.9 | 43.2 | 20 | 21 |
| AS32□1F-02-06ST | 6 | R 3/8 | 19 | 12.8 | 23 | 9.5 | 29.5 | 41 | 20.9 | 53.7 | 1.5 | 47.4 | 18.5 | | | | |
| AS32□1F-02-08ST | 8 | | | 15.2 | | | | | | | | | | 31.8 | 43.3 | 21 | 17 |
| AS32□1F-02-10ST | 10 | | | 18.5 | | | | | | | | | | 33.9 | 43.2 | 20 | 21 |
| AS32□1F-03-06ST | 6 | R 1/2 | 24 | 12.8 | 28.6 | 12 | 27.8 | 39.3 | 25.4 | 63.8 | 1.5 | 55.8 | 22 | | | | |
| AS32□1F-03-08ST | 8 | | | 15.2 | | | | | | | | | | 31.8 | 43.3 | 21 | 17 |
| AS32□1F-03-10ST | 10 | | | 18.5 | | | | | | | | | | 33.9 | 43.2 | 20 | 21 |
| AS42□1F-04-10ST | 12 | R 1/2 | 24 | 20.9 | 28.6 | 12 | 34.6 | 48.9 | 25.4 | 63.8 | 1.5 | 55.8 | 22 | | | | |
| AS42□1F-04-12ST | 12 | | | 20.9 | | | | | | | | | | 34.6 | 48.9 | 25.4 | 63.8 |

* Reference dimensions of M5 x 0.8, R threads after installation.

Inch Size

| Model | d | T | H | D1 | D2 | D3 | L1 | L2 | L3 | L4 | L5 | A* | M1 | | |
|--------------------|-------|-----------|------|---------|------|------|------|------|------|------|------|------|------|------|------|
| AS12□1F-U10/32-01T | 1/8" | 10-32 UNF | 8 | 8.4 | 9.6 | 4.5 | 17.3 | 22.1 | 12.3 | 31 | 0.7 | 27.4 | 12.7 | | |
| AS12□1F-U10/32-03T | 5/32" | | | 9.3 | | | 20.4 | 27.5 | 12.7 | | | | | | |
| AS12□1F-U10/32-05T | 3/16" | | | 11.4 | | | 21.3 | 26.1 | 11.7 | | | | | 13.5 | |
| AS12□1F-U10/32-07T | 1/4" | NPT 1/8 | 12.7 | 12 | 14.2 | 7 | 18.3 | 23.1 | 11.7 | 35.6 | 1.5 | 31.6 | 12.7 | | |
| AS22□1F-N01-01ST | 1/8" | | | 8.4 | | | 20.4 | 27.5 | 14.3 | | | | | 18.5 | |
| AS22□1F-N01-03ST | 5/32" | | | 9.3 | | | 23.1 | 30.2 | 15 | | | | | 21 | |
| AS22□1F-N01-05ST | 3/16" | NPT 1/4 | 17.5 | 11.4 | 18.5 | 7 | 13.2 | 23.9 | 31 | 40.7 | 1.5 | 34.7 | 18.5 | | |
| AS22□1F-N01-07ST | 1/4" | | | 15.2 | | | 23.9 | 31 | 15 | | | | | 21 | |
| AS22□1F-N01-09ST | 5/16" | | | 15.2 | | | 25.2 | 34.4 | 15 | | | | | 16 | |
| AS22□1F-N02-03ST | 5/32" | NPT 1/4 | 17.5 | 10.4 | 23 | 9.5 | 25.2 | 34.4 | 20 | 53.7 | 1.5 | 47.4 | 18.5 | | |
| AS22□1F-N02-05ST | 3/16" | | | 11.4 | | | 24.9 | 34.2 | | | | | | 18.2 | 17 |
| AS22□1F-N02-07ST | 1/4" | | | 13.2 | | | 25.2 | 34.5 | | | | | | 18.2 | 17 |
| AS22□1F-N02-09ST | 5/16" | NPT 3/8 | 19 | 15.2 | 23 | 9.5 | 17.9 | 27.2 | 36.4 | 20.9 | 53.7 | 1.5 | 47.4 | | |
| AS22□1F-N02-11ST | 3/8" | | | 17.9 | | | 33.9 | 43.2 | 20 | | | | | 21 | |
| AS32□1F-N02-07ST | 1/4" | | | 13.2 | | | 27.8 | 39.3 | 21 | | | | | 17 | |
| AS32□1F-N02-09ST | 5/16" | NPT 1/2 | 23.8 | 15.2 | 23 | 9.5 | 17.9 | 29.5 | 41 | 25.4 | 63.8 | 1.5 | 55.8 | | |
| AS32□1F-N02-11ST | 3/8" | | | 19 | | | 31.8 | 43.3 | 21 | | | | | 17 | |
| AS32□1F-N03-07ST | 1/4" | | | 13.2 | | | 27.8 | 39.3 | 21 | | | | | 17 | |
| AS32□1F-N03-09ST | 5/16" | NPT 3/8 | 19 | 15.2 | 23 | 9.5 | 17.9 | 29.5 | 41 | 20.9 | 53.7 | 1.5 | 47.4 | | |
| AS32□1F-N03-11ST | 3/8" | | | 19 | | | 31.8 | 43.3 | 21 | | | | | 17 | |
| AS42□1F-N04-11ST | 3/8" | | | NPT 1/2 | | | 23.8 | 17.9 | 23 | | | | | 9.5 | 17.9 |
| AS42□1F-N04-13ST | 1/2" | 21 | 35.2 | | 49.5 | 25.4 | | 63.8 | | 1.5 | 55.8 | 22 | | | |

* Reference dimensions of 10-32 UNF and NPT threads after installation.

Dimensions

Universal type

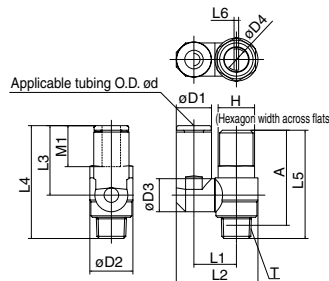

Metric Size

| Model | d | T | H | D1 | D2 | D3 | D4 | L1 | L2 | L3 | L4 | L5 | L6 | A* | M1 | |
|-----------------|-----|----------|------|------|------|------|------|------|------|------|------|------|------|------|------|------|
| AS13□1F-M5-23T | 3.2 | M5 x 0.8 | 8 | 8.4 | 9.6 | 9.3 | 4.5 | 10.8 | 19.8 | 17.5 | 28.7 | 31 | 0.7 | 27.4 | 12.7 | |
| AS13□1F-M5-04T | 4 | | | 9.3 | | | | 20.3 | 20.3 | 17.5 | 28.7 | | | | | 12.7 |
| AS13□1F-M5-06T | 6 | | | 11.6 | | | | 21.4 | 20.6 | 31.8 | 13.5 | | | | | |
| AS23□1F-01-23ST | 3.2 | R 1/8 | 12 | 8.4 | 14.2 | 10.9 | 7 | 13.1 | 24.4 | 17.5 | 31.8 | 35.6 | 1.5 | 31.6 | 12.7 | |
| AS23□1F-01-04ST | 4 | | | 9.3 | | | | 24.9 | 22.9 | 37.2 | 13.5 | | | | | |
| AS23□1F-01-06ST | 6 | | | 11.6 | | | | 14 | 26.9 | 37.2 | 18.5 | | | | | |
| AS23□1F-01-08ST | 8 | R 1/4 | 17 | 15.2 | 12.9 | 7 | 16.2 | 30.9 | 28.2 | 41.7 | 40.7 | 1.5 | 34.7 | 18.5 | | |
| AS23□1F-02-04ST | 4 | | | 10.4 | | | | 16.2 | 30.6 | 21.9 | | | | | 40.1 | 16 |
| AS23□1F-02-06ST | 6 | | | 12.8 | | | | 18.4 | 34 | 25.2 | | | | | 42.6 | 17 |
| AS23□1F-02-08ST | 8 | R 1/4 | 19 | 15.2 | 12.9 | 7 | 18.3 | 35.2 | 28.2 | 45.6 | 40.7 | 1.5 | 34.7 | 18.5 | | |
| AS23□1F-02-10ST | 10 | | | 18.5 | | | | 20.2 | 38.7 | 31 | | | | | 48.4 | 21 |
| AS23□1F-02-12ST | 12 | | | 20.9 | | | | 20.2 | 38.7 | 31 | | | | | 48.4 | 22 |
| AS33□1F-02-06ST | 6 | R 1/4 | 19 | 12.8 | 23 | 9.5 | 20.6 | 38.5 | 25.2 | 47 | 55.3 | 1.5 | 49.3 | 18.5 | | |
| AS33□1F-02-08ST | 8 | | | 15.2 | | | | 39.7 | 28.2 | 50 | | | | | 21 | |
| AS33□1F-02-10ST | 10 | | | 18.5 | | | | 43.7 | 32.6 | 54.4 | | | | | 21 | |
| AS33□1F-02-12ST | 12 | R 3/8 | 19 | 20.9 | 23 | 9.5 | 20.6 | 44.9 | 34.4 | 56.2 | 53.7 | 1.5 | 47.4 | 18.5 | | |
| AS33□1F-03-06ST | 6 | | | 12.8 | | | | 38.5 | 25.2 | 46.1 | | | | | 17 | |
| AS33□1F-03-08ST | 8 | | | 15.2 | | | | 39.7 | 28.2 | 49.1 | | | | | 21 | |
| AS33□1F-03-10ST | 10 | R 1/2 | 24 | 18.5 | 28.6 | 12 | 25.8 | 49.4 | 32.6 | 58 | 63.8 | 1.5 | 55.8 | 21 | | |
| AS33□1F-03-12ST | 12 | | | 20.9 | | | | 44.9 | 34.4 | 55.3 | | | | | 22 | |
| AS43□1F-04-10ST | 10 | | | 20.9 | | | | 25.8 | 49.4 | 32.6 | | | | | 58 | 21 |
| AS43□1F-04-12ST | 12 | 20.9 | 28.6 | 52 | 36.3 | 61.7 | 22 | | | | | | | | | |

* Reference dimensions of M5 x 0.8, R threads after installation.

Inch Size

| Model | d | T | H | D1 | D2 | D3 | D4 | L1 | L2 | L3 | L4 | L5 | L6 | A* | M1 | |
|--------------------|-------|-----------|------|---------|------|------|------|------|------|------|------|------|------|------|------|------|
| AS13□1F-U10/32-01T | 1/8" | 10-32 UNF | 8 | 8.4 | 9.6 | 9.3 | 4.5 | 10.8 | 19.8 | 17.5 | 28.7 | 31 | 0.7 | 27.4 | 12.7 | |
| AS13□1F-U10/32-03T | 5/32" | | | 9.3 | | | | 20.3 | 20.3 | 17.5 | 28.7 | | | | | 12.7 |
| AS13□1F-U10/32-05T | 3/16" | | | 11.4 | | | | 21.3 | 23.3 | 34.5 | 31 | | | | | 0.7 |
| AS13□1F-U10/32-07T | 1/4" | NPT 1/8 | 12.7 | 12 | 14.2 | 7 | 12.7 | 21.6 | 20.7 | 31.9 | 35.6 | 1.5 | 31.6 | 12.7 | | |
| AS23□1F-N01-01ST | 1/8" | | | 8.4 | | | 24.4 | 17.5 | 31.8 | 18.5 | | | | | | |
| AS23□1F-N01-03ST | 5/32" | | | 9.3 | | | 24.9 | 31.8 | 18.5 | | | | | | | |
| AS23□1F-N01-05ST | 3/16" | NPT 1/4 | 17.5 | 11.4 | 19 | 7 | 14 | 26.8 | 23.9 | 41.7 | 40.7 | 1.5 | 34.7 | 18.5 | | |
| AS23□1F-N01-07ST | 1/4" | | | 13.2 | | | 29.9 | 25.6 | 37.2 | 21 | | | | | | |
| AS23□1F-N01-09ST | 5/16" | | | 15.2 | | | 30.9 | 28.2 | 41.7 | 18.5 | | | | | | |
| AS23□1F-N02-03ST | 5/32" | NPT 1/4 | 17.5 | 10.4 | 23 | 9.5 | 10.9 | 30.6 | 21.9 | 40.1 | 20.9 | 53.7 | 1.5 | 47.4 | | |
| AS23□1F-N02-05ST | 3/16" | | | 11.4 | | | 31.1 | 23.9 | 42.6 | 17 | | | | | | |
| AS23□1F-N02-07ST | 1/4" | | | 13.2 | | | 34.2 | 25.6 | 45.6 | 18.5 | | | | | | |
| AS23□1F-N02-09ST | 5/16" | NPT 3/8 | 19 | 15.2 | 23 | 9.5 | 12.9 | 35.2 | 28.2 | 48.4 | 25.4 | 63.8 | 1.5 | 55.8 | | |
| AS23□1F-N02-11ST | 3/8" | | | 17.9 | | | 38.7 | 31 | 47 | 21 | | | | | | |
| AS33□1F-N02-07ST | 1/4" | | | 13.2 | | | 38.7 | 25.6 | 50 | 17 | | | | | | |
| AS33□1F-N02-09ST | 5/16" | NPT 1/4 | 19 | 15.2 | 23 | 9.5 | 12.9 | 39.7 | 28.2 | 54.4 | 55.3 | 1.5 | 49.3 | 18.5 | | |
| AS33□1F-N02-11ST | 3/8" | | | 17.9 | | | 43.7 | 32.6 | 56.2 | 21 | | | | | | |
| AS33□1F-N03-07ST | 1/4" | | | 13.2 | | | 38.7 | 25.6 | 46.1 | 17 | | | | | | |
| AS33□1F-N03-09ST | 5/16" | NPT 3/8 | 19 | 15.2 | 23 | 9.5 | 12.9 | 39.7 | 28.2 | 49.1 | 53.7 | 1.5 | 47.4 | 18.5 | | |
| AS33□1F-N03-11ST | 3/8" | | | 17.9 | | | 43.7 | 32.6 | 53.5 | 21 | | | | | | |
| AS43□1F-N04-11ST | 3/8" | | | NPT 1/2 | | | 23.8 | 17.9 | 23 | 9.5 | | | | | 17.9 | 25.8 |
| AS43□1F-N04-13ST | 1/2" | 21 | 26.8 | | 52 | 36.3 | | 58 | | | 21 | | | | | |

* Reference dimensions of 10-32 UNF and NPT threads after installation.

Tamper Proof Speed Controller with One-touch Fittings

Series AS□□□1F-T

In-line Type



Specifications

| | |
|--------------------------------|---------------------------------|
| Fluid | Air |
| Proof pressure | 1.5 MPa |
| Max. operating pressure | 1 MPa |
| Min. operating pressure | 0.1 MPa |
| Ambient and fluid temperature | -5 to 60°C (No freezing) |
| Number of needle rotations | 10 turns (8 turns (1)) |
| Applicable tubing material (2) | Nylon, Soft nylon, Polyurethane |

Note 1) In the case of AS1001F type

Note 2) Use caution regarding the max. operating pressure when soft nylon or polyurethane tubing is used.
(Refer to pages 15-6-3 to 15-6-5 for details.)

Model

| Model | Applicable tubing O.D. | | | | | | | | | | | | Applicable cylinder bore size (mm) | |
|---------|------------------------|---|---|---|----|----|-----------|-------|-------|------|-------|------|------------------------------------|----------------|
| | Metric size | | | | | | Inch size | | | | | | | |
| | 3.2 | 4 | 6 | 8 | 10 | 12 | 1/8" | 5/32" | 3/16" | 1/4" | 5/16" | 3/8" | | 1/2" |
| AS1001F | ● | ● | ● | | | | ● | ● | ● | ● | | | | 6, 10, 16, 20 |
| AS2001F | | ● | ● | | | | | ● | ● | ● | | | | 20, 25, 32 |
| AS2051F | | | ● | ● | | | | | ● | ● | ● | | | 20, 25, 32, 40 |
| AS3001F | | | ● | ● | ● | ● | | | ● | ● | ● | | | 40, 50, 63 |
| AS4001F | | | | | ● | ● | | | | | | ● | ● | 63, 80, 100 |

AS

ASP

ASN

AQ

ASV

AK

ASS

ASR

ASF

Flow Rate and Effective Area

| Model | | AS1001F | AS2001F | AS2051F | AS3001F | | AS4001F | | | | |
|-----------------------------|-----------------------------------|--------------------------------|---------|-----------------|---------|-----------------|---------|--------|----------|-------|-------|
| Tubing O.D. | Metric size | ø3.2, ø4, ø6 | ø4 | ø6 | ø6 | ø8 | ø6 | ø8 | ø10, ø12 | ø10 | ø12 |
| | Inch size | ø1/8", ø5/32" ø3/16", ø1/4" | ø5/32" | ø3/16" ø1/4" | ø3/16" | ø1/4" ø5/16" | ø1/4" | ø5/16" | ø3/8" | ø3/8" | ø1/2" |
| Controlled flow (Free flow) | Flow rate (l/min (ANR)) | 100 | 130 | 230 | 290 | 460 | 420 | 660 | 920 | 1050 | 1390 |
| | Effective area (mm ²) | 1.5 | 2 | 3.5 | 4.5 | 7 | 6.5 | 10 | 14 | 16 | 21 |

Note) Flow rate values are measured at 0.5 MPa and 20°C.

How to Order

AS 200 1F — 06 T

Flow Direction Symbols on Body

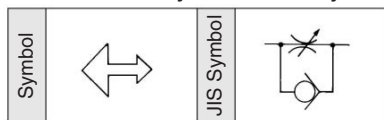

Body size

| | |
|-----|--------------|
| 100 | M5 standard |
| 200 | 1/8 standard |
| 205 | 1/4 standard |
| 300 | 3/8 standard |
| 400 | 1/2 standard |

With One-touch fittings

Tamper proof

Note) Speed controller requires a special tool for flow adjustment. Order separately with part number, AS-T-1.

Applicable tubing O.D.

| Metric size | | Inch size | |
|-------------|--------|-----------|--------|
| 23 | ø3.2 * | 01 | ø1/8" |
| 04 | ø4 | 03 | ø5/32" |
| 06 | ø6 | 05 | ø3/16" |
| 08 | ø8 | 07 | ø1/4" |
| 10 | ø10 | 09 | ø5/16" |
| 12 | ø12 | 11 | ø3/8" |
| | | 13 | ø1/2" |

* Use ø1/8" tube.

Needle Valve/Flow Characteristics

AS1001F

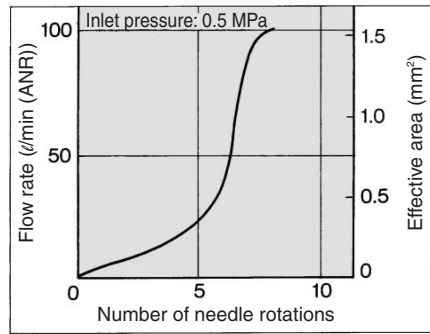

AS2001F

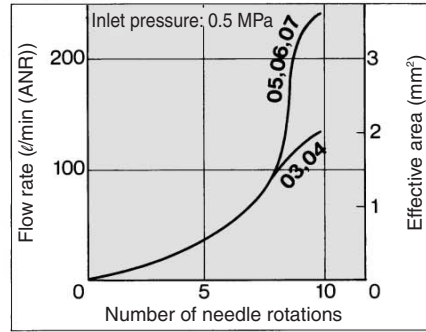

AS2051F

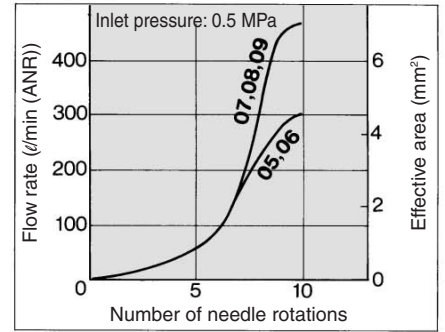

AS3001F

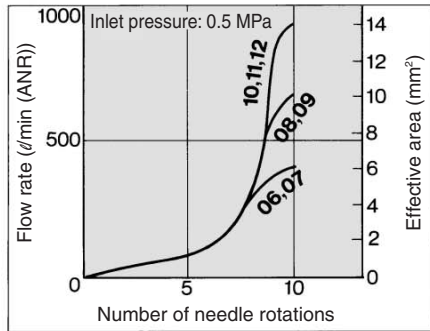

AS4001F

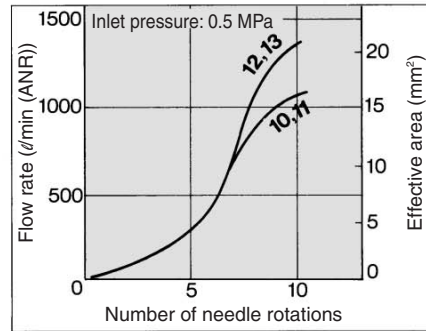

Construction

AS1001F

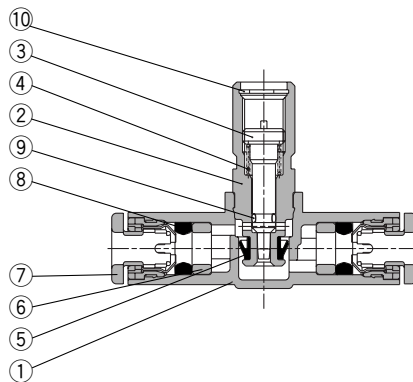

AS2001F to AS4001F

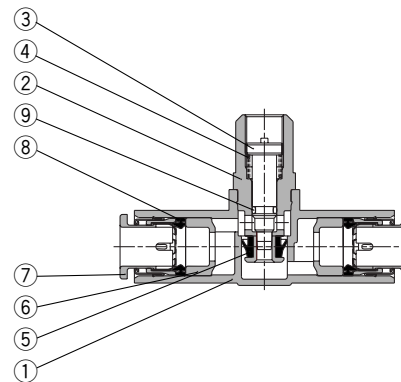

Component Parts

| No. | Description | Material | Note |
|-----|--------------------------------|-------------------------------------|---------------------------|
| ① | Body A | PBT | |
| ② | Body B | Brass | Electroless nickel plated |
| ③ | Needle | Brass | Electroless nickel plated |
| ④ | Spring | Steel wire | |
| ⑤ | U seal | HNBR | |
| ⑥ | Spacer | POM ⁽¹⁾ | |
| ⑦ | Cassette | POM, Stainless steel ⁽²⁾ | |
| ⑧ | Seal | NBR | |
| ⑨ | O-ring | NBR | |
| ⑩ | Retaining ring for hole type C | Tool steel | |

Note 1) $\phi 3/16"$, $\phi 3/8"$, $\phi 1/2"$ are made of brass (Electroless nickel plated).

Note 2) $\phi 3/16"$, $\phi 5/16"$, $\phi 3/8"$, $\phi 1/2"$ are made of POM, stainless steel, brass (Electroless nickel plated).

Tamper Proof Speed Controller With One-touch Fittings, In-line Type

Dimensions

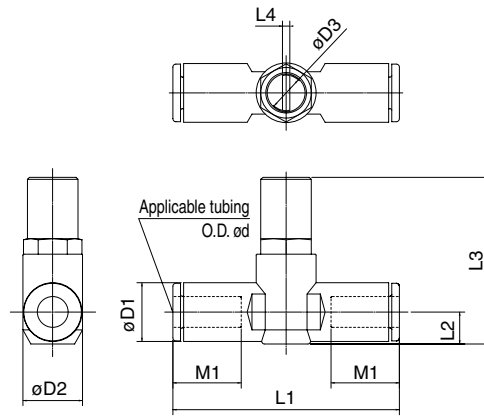

Metric Size

| Model | d | D1 | D2 | D3 | L1 | L2 | L3 | L4 | M1 |
|-------------|-----|------|------|-----|------|------|------|-----|------|
| AS1001F-23T | 3.2 | 8.4 | 10 | 4.5 | 38 | 4.5 | 26 | 0.7 | 12.7 |
| AS1001F-04T | 4 | 9.3 | | | 39.2 | 5.2 | 26.6 | | 13.5 |
| AS1001F-06T | 6 | 11.6 | 11.8 | 7 | 40.7 | 6.2 | 27.7 | 1.5 | 12.7 |
| AS2001F-04T | 4 | 9.3 | | | 44.8 | 6.3 | 31.9 | | 13.5 |
| AS2001F-06T | 6 | 11.6 | 14.8 | 7 | 53.2 | 6.7 | 35.2 | 1.5 | 17 |
| AS2051F-06T | 6 | 12.8 | | | 59.8 | 8.1 | 36.5 | | 18 |
| AS2051F-08T | 8 | 15.2 | 19.8 | 9.5 | 59 | 7.4 | 45 | 1.5 | 17 |
| AS3001F-06T | 6 | 12.8 | | | 64.4 | 8.2 | 45.8 | | 18 |
| AS3001F-08T | 8 | 15.2 | 26.5 | 12 | 71.6 | 9.8 | 47.3 | 1.5 | 21 |
| AS3001F-10T | 10 | 18.5 | | | 76 | 11 | 48.5 | | 22 |
| AS3001F-12T | 12 | 20.9 | 26.5 | 12 | 82 | 11.3 | 55.4 | 1.5 | 21 |
| AS4001F-10T | 10 | 18.5 | | | | | | | 56.4 |
| AS4001F-12T | 12 | 20.9 | | | | | | | 22 |

Inch Size

| Model | d | D1 | D2 | D3 | L1 | L2 | L3 | L4 | M1 |
|-------------|-------|------|------|-----|------|------|------|-----|------|
| AS1001F-01T | 1/8" | 8.4 | 10 | 4.5 | 38 | 4.5 | 26 | 0.7 | 12.7 |
| AS1001F-03T | 5/32" | 9.3 | | | 39.2 | 5.2 | 26.6 | | 13.5 |
| AS1001F-05T | 3/16" | 11.4 | 11.8 | 7 | 40.7 | 6.2 | 27.7 | 1.5 | 12.7 |
| AS1001F-07T | 1/4" | 12 | | | 44.8 | 6.3 | 31.9 | | 13.5 |
| AS2001F-03T | 5/32" | 9.3 | 14.8 | 7 | 53.2 | 6.7 | 35.2 | 1.5 | 17 |
| AS2001F-05T | 3/16" | 11.4 | | | 59.8 | 8.1 | 36.5 | | 18 |
| AS2001F-07T | 1/4" | 13.2 | 19.8 | 9.5 | 59 | 7.4 | 45 | 1.5 | 17 |
| AS2051F-05T | 3/16" | 11.4 | | | 64.4 | 8.2 | 45.8 | | 18 |
| AS2051F-07T | 1/4" | 13.2 | 26.5 | 12 | 71.6 | 9.8 | 47.3 | 1.5 | 21 |
| AS2051F-09T | 5/16" | 15.2 | | | 76 | 11 | 48.5 | | 22 |
| AS3001F-07T | 1/4" | 13.2 | 26.5 | 12 | 82 | 11.3 | 55.4 | 1.5 | 21 |
| AS3001F-09T | 5/16" | 15.2 | | | | | | | 56.4 |
| AS3001F-11T | 3/8" | 17.9 | | | | | | | 21 |
| AS4001F-11T | 3/8" | 17.9 | | | | | | | 21 |
| AS4001F-13T | 1/2" | 21.7 | | | | | | | 22 |

AS

ASP

ASN

AQ

ASV

AK

ASS

ASR

ASF

Tamper Proof Speed Controller Standard Type

Series AS□2□0-T

Elbow Type (Metal Body)



Model/ Specifications

| Specifications | Model | AS12□0-M5 | AS12□0-U10/32 | AS22□0-□01 | AS22□0-□02 | AS32□0-□02 | AS32□0-□03 | AS42□0-□04 |
|------------------------------------|---|--------------------------|---------------|----------------|------------|----------------|------------|------------|
| Port size | | M5 x 0.8 | 10-32 UNF | 1/8 | 1/4 | 1/4 | 3/8 | 1/2 |
| Applicable cylinder bore size (mm) | | 6, 10, 16, 20, 25 | | 20, 25, 32, 40 | | 32, 40, 50, 63 | | 80, 100 |
| Fluid | | Air | | | | | | |
| Proof pressure | | 1.5 MPa | | | | | | |
| Max. operating pressure | | 1 MPa | | | | | | |
| Min. operating pressure | | 0.1 MPa | | | | | | |
| Ambient and fluid temperature | | -5 to 60°C (No freezing) | | | | | | |
| Number of needle rotations | | 8 turns | | 10 turns | | | | |
| Controlled flow | Flow rate (l/min (ANR)) | 105 | | 230 | 460 | | 920 | 1700 |
| | (Free flow) Effective area (mm ²) | 1.6 | | 3.5 | 7 | | 14 | 26 |

Note 1) Flow rate values are measured at 0.5 MPa and 20°C.

Note 2) Meter-out and meter-in types can be visually differentiated by the flow direction symbol on the resin body.

Note 3) Brass parts are all electroless nickel plated, provided as standard.

How to Order

JIS Symbol

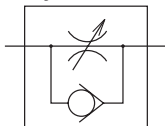

AS 2 2 0 0 - 01 - S T

Body size

| | |
|---|-------------------|
| 1 | M5 standard |
| 2 | 1/8, 1/4 standard |
| 3 | 3/8 standard |
| 4 | 1/2 standard |

Type

| | |
|---|-------|
| 2 | Elbow |
|---|-------|

Control

| | |
|---|-----------|
| 0 | Meter-out |
| 1 | Meter-in |

Tamper proof

Note) Speed controller requires a special tool for flow adjustment. Order separately with part number, AS-T-1.

With seal

Note) When connecting port is either M5 or 10-32 UNF thread, it is not available with seal. With gasket is provided as standard.

Port size

| Symbol | Cylinder side | In the side of solenoid valve |
|--------|---------------|-------------------------------|
| M5 | M5 x 0.8 | M5 x 0.8 |
| 01 | R 1/8 | Rc 1/8 |
| 02 | R 1/4 | Rc 1/4 |
| 03 | R 3/8 | Rc 3/8 |
| 04 | R 1/2 | Rc 1/2 |
| F01 | R 1/8 | G 1/8 |
| F02 | R 1/4 | G 1/4 |
| F03 | R 3/8 | G 3/8 |
| F04 | R 1/2 | G 1/2 |
| U10/32 | 10-32 UNF | 10-32 UNF |
| N01 | NPT 1/8 | NPT 1/8 |
| N02 | NPT 1/4 | NPT 1/4 |
| N03 | NPT 3/8 | NPT 3/8 |
| N04 | NPT 1/2 | NPT 1/2 |

Tamper Proof Speed Controller Standard Type, Elbow Type (Metal Body)

Needle Valve/Flow Characteristics

AS12□0-M5·AS12□0-U10/32

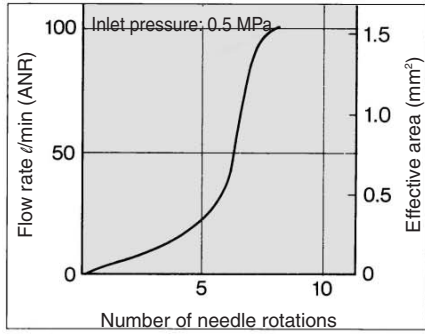

AS22□0-01

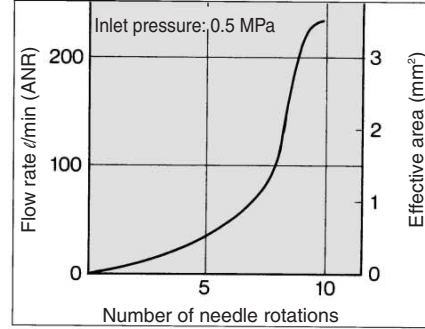

AS22□0-02

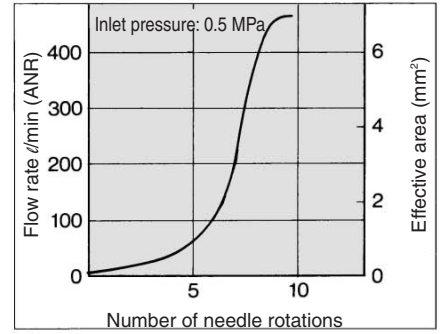

AS32□0

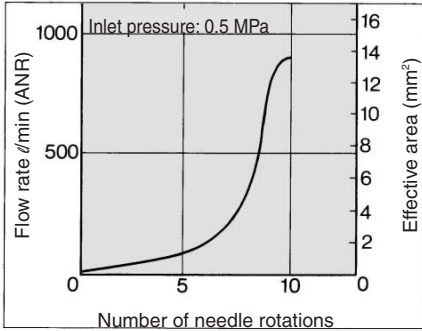

AS42□0

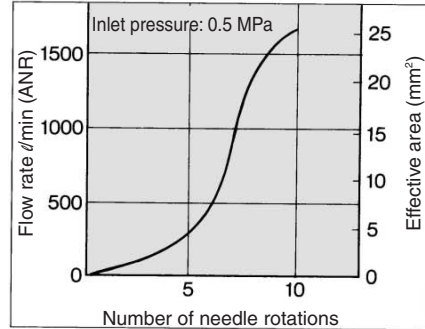

Construction

**Meter-out type
M5 type
U10/32 port**

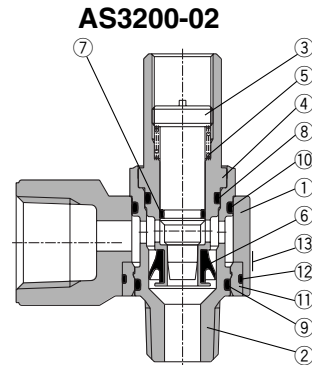
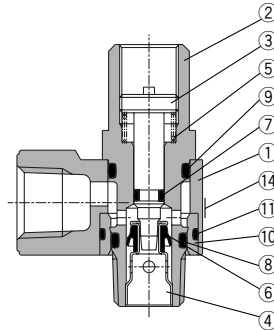
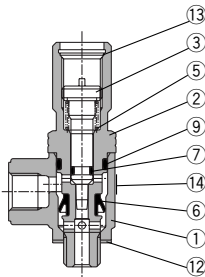

**Meter-in type
M5 type
U10/32 port**

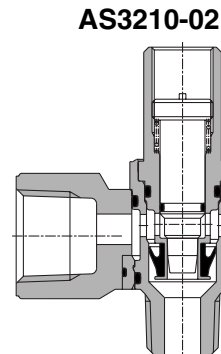
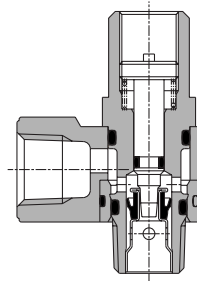
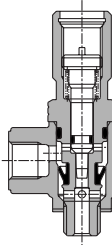

Component Parts

| No. | Description | Material | Note |
|-----|-------------|------------|---------------------------|
| ① | Body A | Zinc alloy | |
| ② | Body B | Brass | Electroless nickel plated |
| ③ | Needle | Brass | Electroless nickel plated |
| ④ | Seat ring | Brass | Electroless nickel plated |
| ⑤ | Spring | Steel wire | |
| ⑥ | U seal | HNBR | |
| ⑦ | O-ring | NBR | |

| No. | Description | Material | Note |
|-----|--------------------------------|----------------------|------|
| ⑧ | O-ring | NBR | |
| ⑨ | O-ring | NBR | |
| ⑩ | Bushing | PBT | |
| ⑪ | O-ring | NBR | |
| ⑫ | Gasket | NBR, Stainless steel | |
| ⑬ | Retaining ring for hole type C | Tool steel | |

AS

ASP

ASN

AQ

ASV

AK

ASS

ASR

ASF

Dimensions

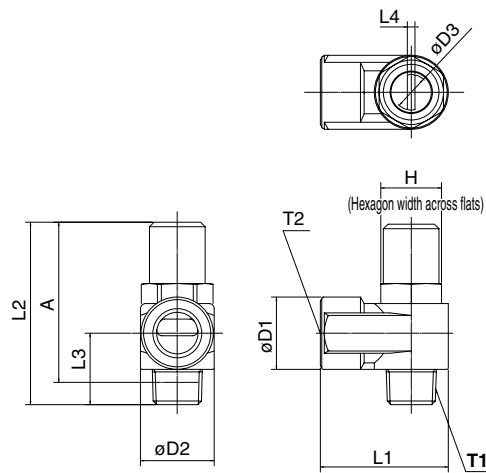

Dimensions

| Model | T1 | T2 | H | D1 | D2 | D3 | L1 | L2 | L3 | L4 | A* |
|-----------------|-----------|-----------|------|------|------|-----|------|------|------|-----|------|
| AS12□0-M5-T | M5 x 0.8 | M5 x 0.8 | 8 | 9 | 9 | 4.5 | 10 | 31 | 10.3 | 0.7 | 27.4 |
| AS12□0-U10/32-T | 10-32 UNF | 10-32 UNF | | | | | | | | | |
| AS22□0-01-ST | R 1/8 | Rc 1/8 | 12 | 14.3 | 14.6 | 7 | 18 | 35.6 | 14.1 | 1.5 | 31.6 |
| AS22□0-F01-ST | | G 1/8 | | | | | | | | | |
| AS22□0-N01-ST | NPT 1/8 | NPT 1/8 | 12.7 | | | | | | | | |
| AS22□0-02-ST | R 1/4 | Rc 1/4 | 17 | 18 | 19.5 | 7 | 27.2 | 40.7 | 18 | 1.5 | 36.7 |
| AS22□0-F02-ST | | G 1/4 | | | | | | | | | |
| AS22□0-N02-ST | NPT 1/4 | NPT 1/4 | 17.5 | | | | | | | | |
| AS32□0-02-ST | R 1/4 | Rc 1/4 | 19 | 22.5 | 24.3 | 9.5 | 30 | 55.3 | 22.4 | 1.5 | 49.3 |
| AS32□0-F02-ST | | G 1/4 | | | | | | | | | |
| AS32□0-N02-ST | NPT 1/4 | NPT 1/4 | | | | | | | | | |
| AS32□0-03-ST | R 3/8 | Rc 3/8 | 19 | 22.5 | 24.3 | 9.5 | 30 | 53.7 | 20.8 | 1.5 | 47.4 |
| AS32□0-F03-ST | | G 3/8 | | | | | | | | | |
| AS32□0-N03-ST | NPT 3/8 | NPT 3/8 | | | | | | | | | |
| AS42□0-04-ST | R 1/2 | Rc 1/2 | 24 | 27.5 | 28.5 | 12 | 38.5 | 63.8 | 26.7 | 1.5 | 55.8 |
| AS42□0-F04-ST | | G 1/2 | | | | | | | | | |
| AS42□0-N04-ST | NPT 1/2 | NPT 1/2 | 23.8 | | | | | | | | |

* Reference thread dimensions after installation.

Speed Controller Adjustable by Flat Head Screwdriver with One-touch Fitting

Series AS□□□1F-D

Elbow Type/Universal Type

Flow adjustable by flat head screwdriver
Prevention of an unnecessary manual operation

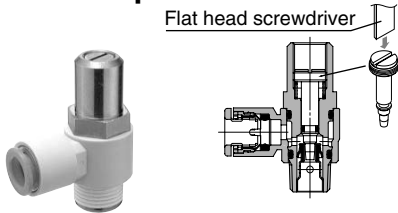

Elbow type



Universal type



JIS Symbol

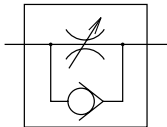

Flow Direction Symbols on Body

| | Meter-out type | Meter-in type |
|------------|----------------|---------------|
| Symbol | | |
| JIS Symbol | | |

Model

| Elbow type | Universal type | Port size | Applicable tubing O.D. | | | | | | | | | | | | Applicable cylinder bore size (mm) | | |
|----------------|----------------|-----------|------------------------|---|---|---|----|----|-----------|-------|-------|------|-------|------|------------------------------------|------|----------------|
| | | | Metric size | | | | | | Inch size | | | | | | | | |
| | | | 3.2 | 4 | 6 | 8 | 10 | 12 | 1/8" | 5/32" | 3/16" | 1/4" | 5/16" | 3/8" | | 1/2" | |
| AS12□1F-M5 | AS13□1F-M5 | M5 x 0.8 | ● | ● | ● | | | | | | | | | | | | 6, 10, 16, 20 |
| AS22□1F-01 | AS23□1F-01 | R 1/8 | ● | ● | ● | ● | ● | | | | | | | | | | 20, 25, 32 |
| AS22□1F-02 | AS23□1F-02 | R 1/4 | | ● | ● | ● | ● | | | | | | | | | | 20, 25, 32, 40 |
| AS32□1F-02 | AS33□1F-02 | R 1/4 | | | ● | ● | ● | ● | | | | | | | | | 40, 50, 63 |
| AS32□1F-03 | AS33□1F-03 | R 3/8 | | | ● | ● | ● | ● | | | | | | | | | 40, 50, 63 |
| AS42□1F-04 | AS43□1F-04 | R 1/2 | | | | | | ● | ● | | | | | | | | 63, 80, 100 |
| AS12□1F-U10/32 | AS13□1F-U10/32 | 10-32 UNF | | | | | | | | ● | ● | ● | ● | | | | 6, 10, 16, 20 |
| AS22□1F-N01 | AS23□1F-N01 | NPT 1/8 | | | | | | | | ● | ● | ● | ● | ● | | | 20, 25, 32 |
| AS22□1F-N02 | AS23□1F-N02 | NPT 1/4 | | | | | | | | | ● | ● | ● | ● | ● | | 20, 25, 32, 40 |
| AS32□1F-N02 | AS33□1F-N02 | NPT 1/4 | | | | | | | | | | ● | ● | ● | ● | | 40, 50, 63 |
| AS32□1F-N03 | AS33□1F-N03 | NPT 3/8 | | | | | | | | | | | ● | ● | ● | | 40, 50, 63 |
| AS42□1F-N04 | AS43□1F-N04 | NPT 1/2 | | | | | | | | | | | | | ● | ● | 63, 80, 100 |

Note 1) * Elbow type only

Note 2) Meter-out and meter-in types can be visually differentiated by the flow direction symbol on the resin body.

Specifications

| | |
|---|------------------------------------|
| Fluid | Air |
| Proof pressure | 1.5 MPa |
| Max. operating pressure | 1 MPa |
| Min. operating pressure | 0.1 MPa |
| Ambient and fluid temperature | -5 to 60°C (No freezing) |
| Number of needle rotations | 10 turns (8 turns ⁽¹⁾) |
| Applicable tubing material ⁽²⁾ | Nylon, Soft nylon, Polyurethane |

Note 1) In the case of AS121□F-M5 and AS12□1F-U10/32 types
AS13□1F-M5, AS13□1F-U10/32

Note 2) Use caution regarding the max. operating pressure when soft nylon or polyurethane tubing is used. (Refer to pages 15-6-3 to 15-6-5 for details.)

Note 3) Brass parts are all electroless nickel plated, provided as standard.

Flow Rate and Effective Area

| Model | AS12□1F AS13□1F | AS22□1F-□01 AS23□1F-□01 | AS22□1F-□02 AS23□1F-□02 | AS32□1F AS33□1F | | AS42□1F AS43□1F | | | | | | |
|-----------------------------|-----------------------------------|----------------------------|----------------------------|--------------------|--------------|--------------------|------------|-----|-----|-----|------|------|
| | Metric size | 3.2, 4, 6 | 3.2, 4, 6, 8, 10 | 4, 6, 8, 10 | 6, 8, 10, 12 | 10, 12 | 10, 12 | | | | | |
| Tubing O.D. | Inch size | 1/8", 5/32", 3/16", 1/4" | 1/8", 5/32", 5/16" | 3/16", 1/4", 5/16" | 1/4", 5/16" | 3/8" | 3/8", 1/2" | | | | | |
| Controlled flow (Free flow) | Flow rate (l/min (ANR)) | 100 | 180 | 230 | 260 | 390 | 460 | 660 | 790 | 920 | 1580 | 1710 |
| | Effective area (mm ²) | 1.5 | 2.7 | 3.5 | 4 | 6 | 7 | 10 | 12 | 14 | 24 | 26 |

Note) Flow rate values are measured at 0.5 MPa and 20°C.

AS

ASP

ASN

AQ

ASV

AK

ASS

ASR

ASF

How to Order

AS 2 2 1 1 F — 01 — 06 S D

Body size

| | |
|---|-------------------|
| 1 | M5 standard |
| 2 | 1/8, 1/4 standard |
| 3 | 3/8 standard |
| 4 | 1/2 standard |

Type

| | |
|---|-----------|
| 2 | Elbow |
| 3 | Universal |

Control

| | |
|---|-----------|
| 0 | Meter-out |
| 1 | Meter-in |

With One-touch fitting

Type adjustable by flat head screwdriver

With seal

Note) In the case that connecting port is either M5 or 10-32 UNF thread, it is not available with seal. With gasket is provided as standard.

Applicable tubing O.D.

| Metric size | Inch size |
|-------------|-----------|
| 23 | ø3.2 * |
| 04 | ø4 |
| 06 | ø6 |
| 08 | ø8 |
| 10 | ø10 |
| 12 | ø12 |
| 01 | ø1/8" |
| 03 | ø5/32" |
| 05 | ø3/16" |
| 07 | ø1/4" |
| 09 | ø5/16" |
| 11 | ø3/8" |
| 13 | ø1/2" |

* Use ø1/8" tube.

Port size

| | |
|--------|-----------|
| M5 | M5 x 0.8 |
| 01 | R 1/8 |
| 02 | R 1/4 |
| 03 | R 3/8 |
| 04 | R 1/2 |
| U10/32 | 10-32 UNF |
| N01 | NPT 1/8 |
| N02 | NPT 1/4 |
| N03 | NPT 3/8 |
| N04 | NPT 1/2 |

Needle Valve/Flow Characteristics

AS1201FG, AS1211FG

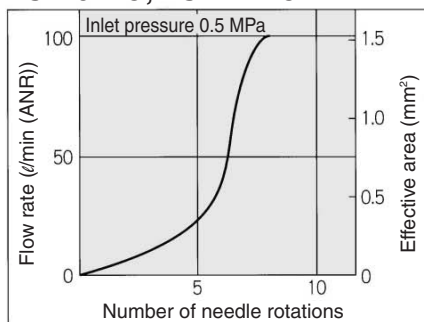

AS2201FG-01, AS2211FG-01

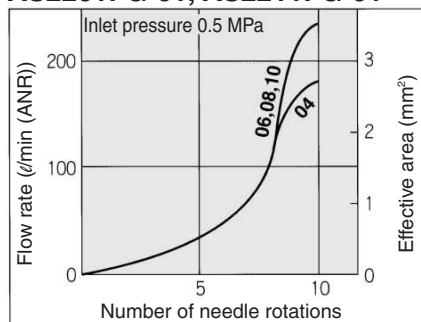

AS2201FG-02, AS2211FG-02

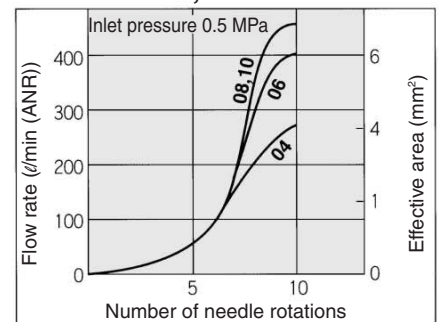

AS3201FG, AS3211FG

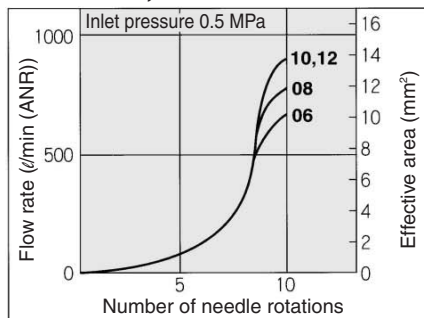

AS4201FG, AS4211FG

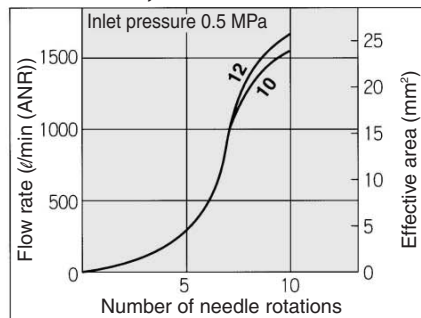

**Speed Controller Adjustable by Flat Head Screwdriver
With One-touch Fitting, Elbow Type/Universal Type**

Construction

**Elbow type
Meter-out type**

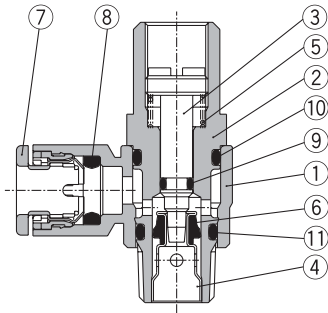

**M5 type
U10/32 port**

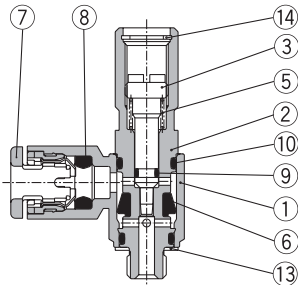

Meter-in type

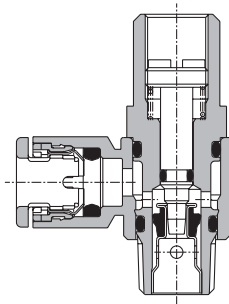

**M5 type
U10/32 port**

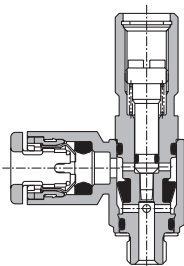

**Universal type
Meter-out type**

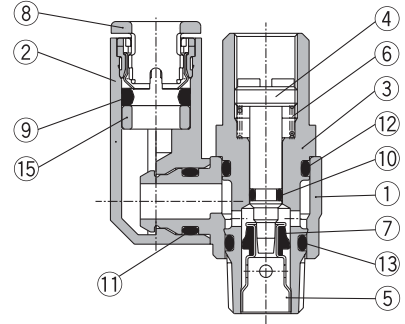

**M5 type
U10/32 port**

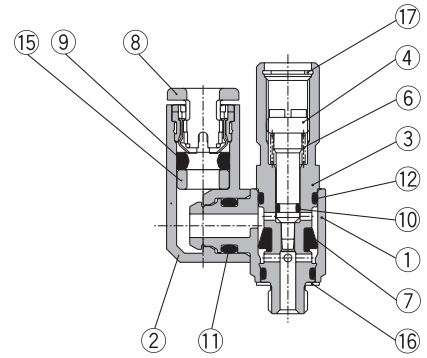

Meter-in type

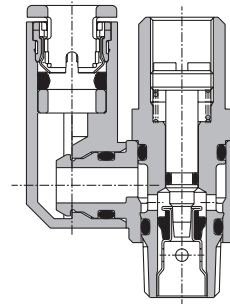

**M5 type
U10/32 port**

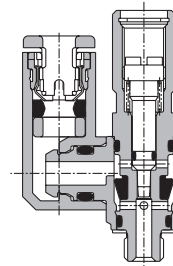

- AS
- ASP
- ASN
- AQ
- ASV
- AK
- ASS
- ASR
- ASF

Construction

Elbow type Meter-out AS3201F-02

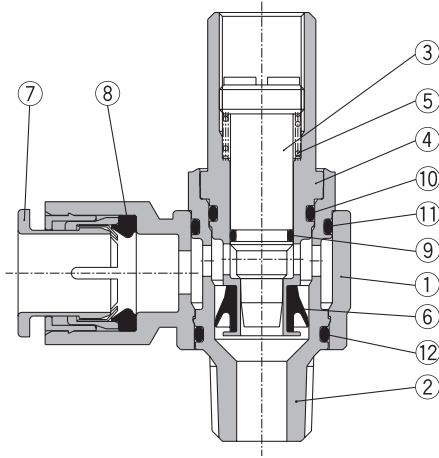

Meter-out AS3301F-02

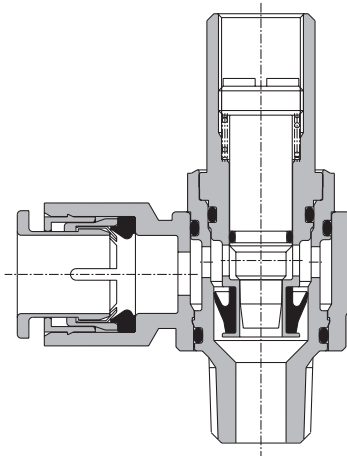

Universal type Meter-out AS3301F-02

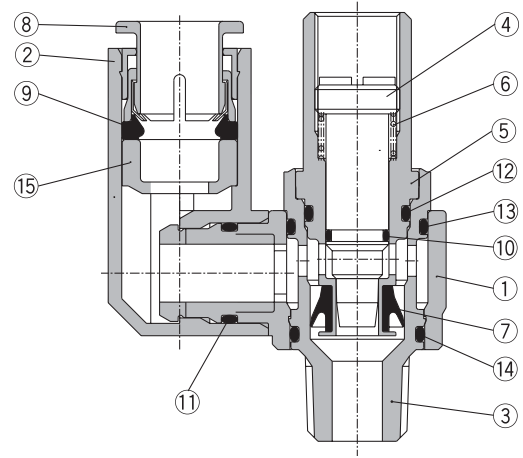

Meter-out AS3311F-02

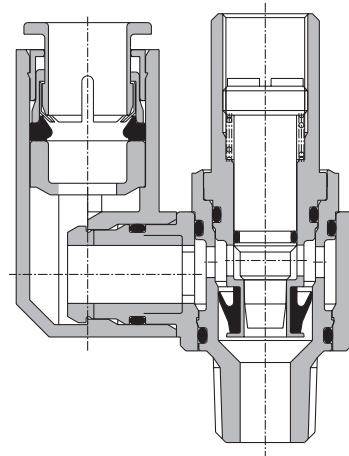

Component Parts

| No. | Description | Material | Note |
|-----|--------------------------------|--|---------------------------|
| ① | Body A | PBT | |
| ② | Body B | Brass | Electroless nickel plated |
| ③ | Needle | Brass | Electroless nickel plated |
| ④ | Seat ring | Brass | Electroless nickel plated |
| ⑤ | Spring | Steel wire | |
| ⑥ | U seal | HNBR | |
| ⑦ | Cassette | POM, Stainless steel ^(Note) | |
| ⑧ | Seal | NBR | |
| ⑨ | O-ring | NBR | |
| ⑩ | O-ring | NBR | |
| ⑪ | O-ring | NBR | |
| ⑫ | O-ring | POM | |
| ⑬ | Gasket | NBR, Stainless steel | |
| ⑭ | Retaining ring for hole type C | Tool steel | |

Note) $\phi 10$, $\phi 12$, $\phi 1/8$ ", $\phi 1/2$ " are made of POM, stainless steel, brass (Electroless nickel plated).

Component Parts

| No. | Description | Material | Note |
|-----|--------------------------------|-------------------------------------|---------------------------|
| ① | Body A | PBT | |
| ② | Elbow body | PBT | |
| ③ | Body B | Brass | Electroless nickel plated |
| ④ | Needle | Brass | Electroless nickel plated |
| ⑤ | Seat ring | Brass | Electroless nickel plated |
| ⑥ | Spring | Steel wire | |
| ⑦ | U seal | HNBR | |
| ⑧ | Cassette | POM, Stainless steel ⁽¹⁾ | |
| ⑨ | Seal | NBR | |
| ⑩ | O-ring | NBR | |
| ⑪ | O-ring | NBR | |
| ⑫ | O-ring | NBR | |
| ⑬ | O-ring | NBR | |
| ⑭ | O-ring | NBR | |
| ⑮ | Spacer | POM ⁽²⁾ | |
| ⑯ | Gasket | NBR, Stainless steel | |
| ⑰ | Retaining ring for hole type C | Tool steel | |

Note 1) $\phi 3/16$ ", $\phi 5/16$ ", $\phi 3/8$ ", $\phi 1/2$ " are made of POM, stainless steel, brass (Electroless nickel plated).

Note 2) $\phi 3/16$ ", $\phi 3/8$ ", $\phi 1/2$ " are made of brass (Electroless nickel plated).

Speed Controller Adjustable by Flat Head Screwdriver With One-touch Fitting, Elbow Type/Universal Type

Dimensions

Elbow type

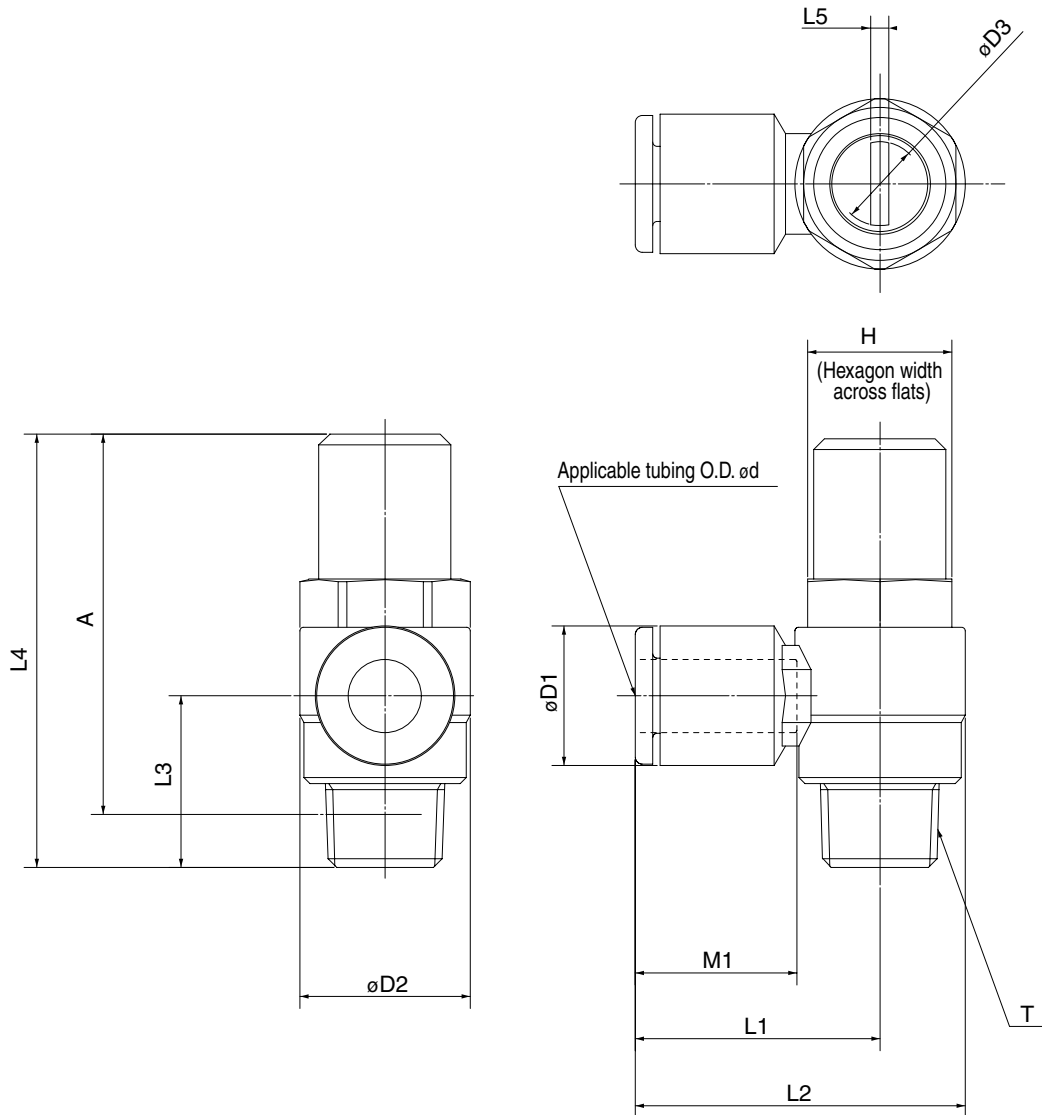

- AS
- ASP
- ASN
- AQ
- ASV
- AK
- ASS
- ASR
- ASF

Metric Size

| Model | d | T | H | D1 | D2 | D3 | L1 | L2 | L3 | L4 | L5 | A* | M1 | | | | | | |
|-----------------|-----|----------|------|------|------|------|------|------|------|------|-----|------|------|------|------|------|------|-----|------|
| AS12□1F-M5-23D | 3.2 | M5 x 0.8 | 8 | 8.4 | 9.6 | 4.7 | 17.3 | 22.1 | 12.3 | 31 | 0.7 | 27.4 | 12.7 | | | | | | |
| AS12□1F-M5-04D | 4 | | | 9.3 | | | | | | | | | | 18.1 | 22.9 | 11.7 | | | |
| AS12□1F-M5-06D | 6 | | | 11.6 | | | | | | | | | | 20.4 | 27.5 | 14.3 | | | |
| AS22□1F-01-23SD | 3.2 | R 1/8 | 12 | 8.4 | 14.2 | 7.2 | 20.4 | 27.5 | 14.3 | 35.6 | 1.2 | 31.6 | 13.5 | | | | | | |
| AS22□1F-01-04SD | 4 | | | 9.3 | | | | | | | | | | 25.3 | 32.4 | 15 | | | |
| AS22□1F-01-06SD | 6 | | | 11.6 | | | | | | | | | | 33.1 | 40.2 | 15 | | | |
| AS22□1F-01-08SD | 8 | 15.2 | 18.5 | 25.3 | 32.4 | 15 | 21 | 21 | 21 | 21 | 21 | 21 | 21 | | | | | | |
| AS22□1F-01-10SD | 10 | 18.5 | 18.5 | 33.1 | 40.2 | 15 | 21 | 21 | 21 | 21 | 21 | 21 | 21 | | | | | | |
| AS22□1F-02-04SD | 4 | R 1/4 | 17 | 10.4 | 18.5 | 7.2 | 25.2 | 34.4 | 18.2 | 40.7 | 1.2 | 34.7 | 16 | | | | | | |
| AS22□1F-02-06SD | 6 | | | 12.8 | | | | | | | | | | 27.8 | 39.3 | 20 | | | |
| AS22□1F-02-08SD | 8 | | | 15.2 | | | | | | | | | | 33.9 | 43.2 | 20 | | | |
| AS22□1F-02-10SD | 10 | 18.5 | 33.9 | 43.2 | 20 | 21 | 21 | 21 | 21 | 21 | 21 | 21 | 21 | | | | | | |
| AS32□1F-02-06SD | 6 | R 1/4 | 19 | 12.8 | 23 | 9.8 | 27.8 | 39.3 | 21.8 | 55.3 | 1.2 | 49.3 | 17 | | | | | | |
| AS32□1F-02-08SD | 8 | | | 15.2 | | | | | | | | | | 29.5 | 41 | 20.9 | 53.7 | 1.2 | 47.4 |
| AS32□1F-02-10SD | 10 | | | 18.5 | | | | | | | | | | 31.8 | 43.3 | 20.9 | 53.7 | 1.2 | 47.4 |
| AS32□1F-02-12SD | 12 | 20.9 | 32.8 | 44.3 | 25.4 | 63.8 | 1.2 | 55.8 | 22 | 22 | 22 | 22 | 22 | | | | | | |
| AS32□1F-03-06SD | 6 | R 3/8 | 19 | 12.8 | 23 | 9.8 | 27.8 | 39.3 | 20.9 | 53.7 | 1.2 | 47.4 | 17 | | | | | | |
| AS32□1F-03-08SD | 8 | | | 15.2 | | | | | | | | | | 29.5 | 41 | 20.9 | 53.7 | 1.2 | 47.4 |
| AS32□1F-03-10SD | 10 | | | 18.5 | | | | | | | | | | 31.8 | 43.3 | 20.9 | 53.7 | 1.2 | 47.4 |
| AS32□1F-03-12SD | 12 | 20.9 | 32.8 | 44.3 | 25.4 | 63.8 | 1.2 | 55.8 | 22 | 22 | 22 | 22 | 22 | | | | | | |
| AS42□1F-04-10SD | 10 | R 1/2 | 24 | 18.5 | 28.6 | 12.4 | 33.6 | 47.9 | 25.4 | 63.8 | 1.2 | 55.8 | 21 | | | | | | |
| AS42□1F-04-12SD | 12 | | | 20.9 | | | | | | | | | | 34.6 | 48.9 | 25.4 | 63.8 | 1.2 | 55.8 |

* Reference dimensions of M5 x 0.8, R threads after installation.

Inch Size

| Model | d | T | H | D1 | D2 | D3 | L1 | L2 | L3 | L4 | L5 | A* | M1 | | | | | | | |
|--------------------|-------|-----------|------|------|------|------|------|------|------|------|------|------|------|------|------|------|------|-----|------|------|
| AS12□1F-U10/32-01D | 1/8" | 10-32 UNF | 8 | 8.4 | 9.6 | 4.7 | 17.3 | 22.1 | 12.3 | 31 | 0.7 | 27.4 | 12.7 | | | | | | | |
| AS12□1F-U10/32-03D | 5/32" | | | 9.3 | | | | | | | | | | 18.1 | 22.9 | 11.7 | | | | |
| AS12□1F-U10/32-05D | 3/16" | | | 11.4 | | | | | | | | | | 20.4 | 27.5 | 14.3 | | | | |
| AS12□1F-U10/32-07D | 1/4" | 12 | 20.4 | 27.5 | 14.3 | 35.6 | 1.2 | 31.6 | 13.5 | 13.5 | 13.5 | 13.5 | | | | | | | | |
| AS22□1F-N01-01SD | 1/8" | NPT 1/8 | 12.7 | 8.4 | 14.2 | 7.2 | 20.4 | 27.5 | 14.3 | 35.6 | 1.2 | 31.6 | 12.7 | | | | | | | |
| AS22□1F-N01-03SD | 5/32" | | | 9.3 | | | | | | | | | | 23.1 | 30.2 | 14.3 | 35.6 | 1.2 | 31.6 | 16.5 |
| AS22□1F-N01-05SD | 3/16" | | | 11.4 | | | | | | | | | | 23.1 | 30.2 | 14.3 | 35.6 | 1.2 | 31.6 | 18.5 |
| AS22□1F-N01-07SD | 1/4" | 13.2 | 23.9 | 31 | 15 | 21 | 21 | 21 | 21 | 21 | 21 | 21 | 21 | | | | | | | |
| AS22□1F-N01-09SD | 5/16" | 15.2 | 25.3 | 32.4 | 15 | 21 | 21 | 21 | 21 | 21 | 21 | 21 | 21 | | | | | | | |
| AS22□1F-N02-03SD | 5/32" | NPT 1/4 | 17.5 | 10.4 | 18.5 | 7.2 | 25.2 | 34.4 | 18.2 | 40.7 | 1.2 | 34.7 | 16 | | | | | | | |
| AS22□1F-N02-05SD | 3/16" | | | 11.4 | | | | | | | | | | 24.9 | 34.2 | 18.2 | 17 | | | |
| AS22□1F-N02-07SD | 1/4" | | | 13.2 | | | | | | | | | | 24.9 | 34.2 | 18.2 | 17 | | | |
| AS22□1F-N02-09SD | 5/16" | 15.2 | 25.2 | 34.5 | 15 | 21 | 21 | 21 | 21 | 21 | 21 | 21 | 21 | | | | | | | |
| AS22□1F-N02-11SD | 3/8" | 17.9 | 27.2 | 36.4 | 20 | 21 | 21 | 21 | 21 | 21 | 21 | 21 | 21 | | | | | | | |
| AS32□1F-N02-07SD | 1/4" | NPT 1/4 | 19 | 13.2 | 23 | 9.8 | 27.8 | 39.3 | 21.8 | 55.3 | 1.2 | 49.3 | 17 | | | | | | | |
| AS32□1F-N02-09SD | 5/16" | | | 15.2 | | | | | | | | | | 29.5 | 41 | 21.8 | 55.3 | 1.2 | 49.3 | 18.5 |
| AS32□1F-N02-11SD | 3/8" | | | 17.9 | | | | | | | | | | 31.8 | 43.3 | 20.9 | 53.7 | 1.2 | 47.4 | 21 |
| AS32□1F-N03-07SD | 1/4" | NPT 3/8 | 19 | 13.2 | 23 | 9.8 | 27.8 | 39.3 | 20.9 | 53.7 | 1.2 | 47.4 | 17 | | | | | | | |
| AS32□1F-N03-09SD | 5/16" | | | 15.2 | | | | | | | | | | 29.5 | 41 | 20.9 | 53.7 | 1.2 | 47.4 | 18.5 |
| AS32□1F-N03-11SD | 3/8" | | | 17.9 | | | | | | | | | | 31.8 | 43.3 | 20.9 | 53.7 | 1.2 | 47.4 | 21 |
| AS32□1F-N03-13SD | 7/16" | 19.5 | 33.6 | 47.9 | 25.4 | 63.8 | 1.2 | 55.8 | 22 | 22 | 22 | 22 | 22 | | | | | | | |
| AS42□1F-N04-11SD | 3/8" | NPT 1/2 | 23.8 | 17.9 | 28.6 | 12.4 | 33.6 | 47.9 | 25.4 | 63.8 | 1.2 | 55.8 | 21 | | | | | | | |
| AS42□1F-N04-13SD | 1/2" | | | 21.7 | | | | | | | | | | 35.2 | 49.5 | 25.4 | 63.8 | 1.2 | 55.8 | 22 |

* Reference dimensions of 10-32 UNF and NPT threads after installation.

Dimensions

Universal type

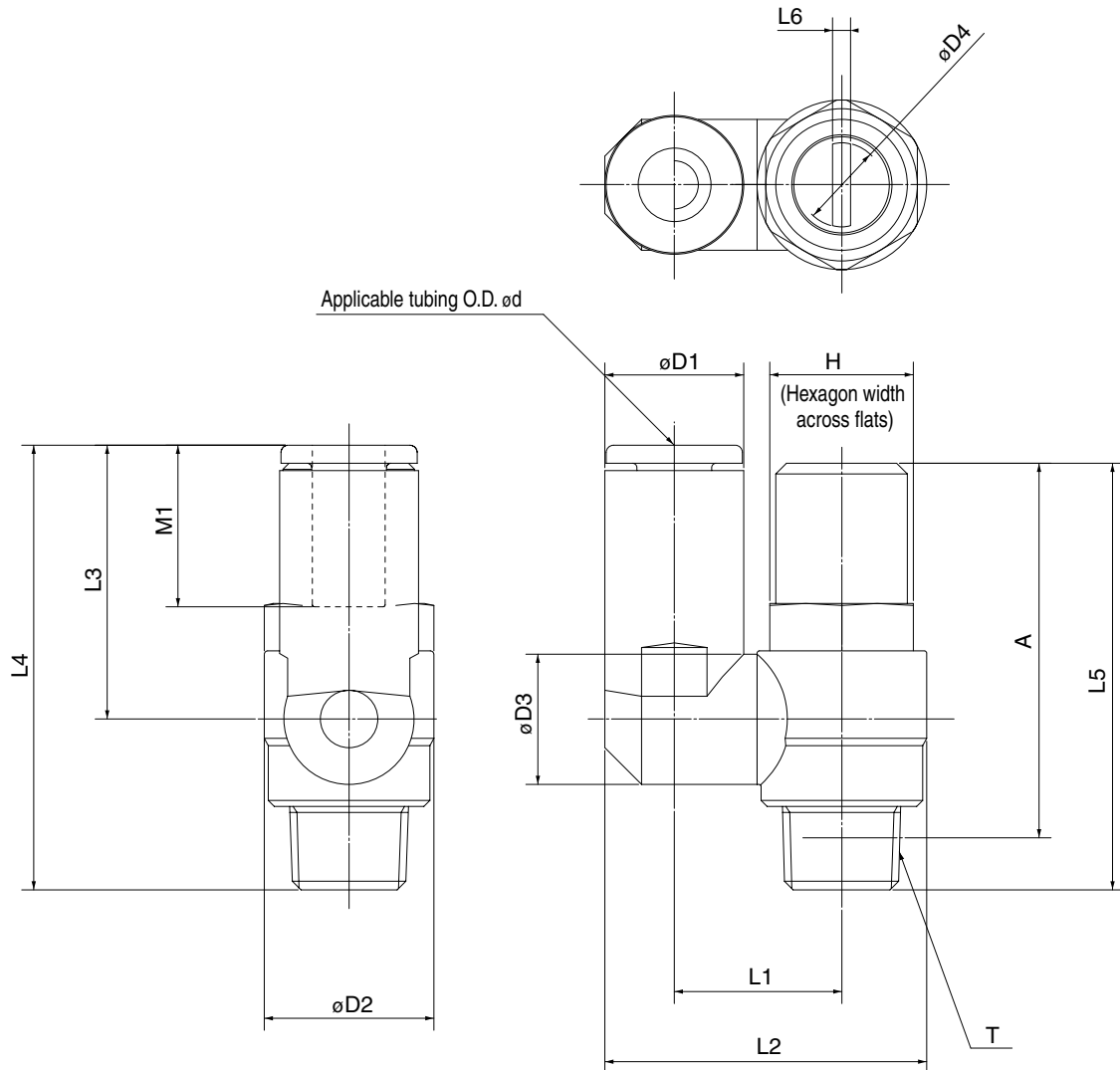

Metric Size

| Model | d | T | H | D1 | D2 | D3 | D4 | L1 | L2 | L3 | L4 | L5 | L6 | A | M1 |
|-----------------|-----|----------|----|------|------|------|------|------|------|------|------|------|-----|------|------|
| AS13□1F-M5-23SD | 3.2 | M5 x 0.8 | 8 | 8.4 | 9.6 | 9.3 | 4.7 | 10.8 | 19.8 | 17.5 | 28.7 | 31 | 0.7 | 27.4 | 12.7 |
| AS13□1F-M5-04D | 4 | | | 9.3 | | | | | 20.3 | | | | | | |
| AS13□1F-M5-06D | 6 | | | 11.6 | | | | | 21.4 | | | | | | |
| AS23□1F-01-23SD | 3.2 | R 1/8 | 12 | 8.4 | 14.2 | 9.3 | 7.2 | 13.1 | 24.4 | 17.5 | 31.8 | 35.6 | 1.2 | 31.6 | 12.7 |
| AS23□1F-01-04SD | 4 | | | 9.3 | | | | | 24.9 | | | | | | |
| AS23□1F-01-06SD | 6 | | | 11.6 | | | | | 14 | | | | | | |
| AS23□1F-01-08SD | 8 | | | 15.2 | | | | | 16.2 | | | | | | |
| AS23□1F-02-04SD | 4 | R 1/4 | 17 | 10.4 | 18.5 | 10.9 | 7.2 | 18.4 | 30.6 | 21.9 | 40.1 | 40.7 | 1.2 | 34.7 | 16 |
| AS23□1F-02-06SD | 6 | | | 12.8 | | | | | 34 | | | | | | |
| AS23□1F-02-08SD | 8 | | | 15.2 | | | | | 28.2 | | | | | | |
| AS23□1F-02-10SD | 10 | | | 18.5 | | | | | 20.2 | | | | | | |
| AS23□1F-02-06SD | 6 | R 1/4 | 19 | 12.8 | 23 | 12.9 | 9.8 | 20.6 | 38.5 | 25.2 | 47 | 55.3 | 1.2 | 49.3 | 17 |
| AS33□1F-02-08SD | 8 | | | 15.2 | | | | | 39.7 | | | | | | |
| AS33□1F-02-10SD | 10 | | | 18.5 | | | | | 43.7 | | | | | | |
| AS33□1F-02-12SD | 12 | | | 20.9 | | | | | 44.9 | | | | | | |
| AS33□1F-03-06SD | 6 | R 3/8 | 19 | 12.8 | 23 | 12.9 | 9.8 | 20.6 | 38.5 | 25.2 | 46.1 | 53.7 | 1.2 | 47.4 | 17 |
| AS33□1F-03-08SD | 8 | | | 15.2 | | | | | 39.7 | | | | | | |
| AS33□1F-03-10SD | 10 | | | 18.5 | | | | | 43.7 | | | | | | |
| AS33□1F-03-12SD | 12 | | | 20.9 | | | | | 44.9 | | | | | | |
| AS43□1F-04-10SD | 10 | R 1/2 | 24 | 18.5 | 28.6 | 16.2 | 12.4 | 25.8 | 49.4 | 32.6 | 58 | 63.8 | 1.2 | 55.8 | 21 |
| AS43□1F-04-12SD | 12 | | | 20.9 | | | | | 26.8 | | | | | | |

* Reference dimensions of M5 x 0.8, R threads after installation.

Inch Size

| Model | d | T | H | D1 | D2 | D3 | D4 | L1 | L2 | L3 | L4 | L5 | L6 | A | M1 |
|--------------------|-------|-----------|------|------|-----|------|------|------|------|------|------|------|-----|------|------|
| AS13□1F-U10/32-01D | 1/8" | 10-32 UNF | 8 | 8.4 | 9.6 | 9.3 | 4.7 | 10.8 | 19.8 | 17.5 | 28.7 | 31 | 0.7 | 27.4 | 12.7 |
| AS13□1F-U10/32-03D | 5/32" | | | 9.3 | | | | | 20.3 | | | | | | |
| AS13□1F-U10/32-05D | 3/16" | | | 11.4 | | | | | 21.3 | | | | | | |
| AS13□1F-U10/32-07D | 1/4" | | | 12 | | | | | 21.6 | | | | | | |
| AS23□1F-N01-01SD | 1/8" | NPT 1/8 | 12.7 | 8.4 | 14 | 10.9 | 7.2 | 14 | 24.4 | 17.5 | 31.8 | 35.6 | 1.2 | 31.6 | 12.7 |
| AS23□1F-N01-03SD | 5/32" | | | 9.3 | | | | | 24.9 | | | | | | |
| AS23□1F-N01-05SD | 3/16" | | | 11.4 | | | | | 26.8 | | | | | | |
| AS23□1F-N01-07SD | 1/4" | | | 13.2 | | | | | 29.9 | | | | | | |
| AS23□1F-N01-09SD | 5/16" | NPT 1/4 | 17.5 | 15.2 | 19 | 12.9 | 7.2 | 18.3 | 30.9 | 28.2 | 41.7 | 40.7 | 1.2 | 34.7 | 18.5 |
| AS23□1F-N02-03SD | 5/32" | | | 10.4 | | | | | 30.6 | | | | | | |
| AS23□1F-N02-05SD | 3/16" | | | 11.4 | | | | | 31.1 | | | | | | |
| AS23□1F-N02-07SD | 1/4" | | | 13.2 | | | | | 34.2 | | | | | | |
| AS23□1F-N02-09SD | 5/16" | NPT 1/4 | 19 | 15.2 | 23 | 16.2 | 9.8 | 20.6 | 35.2 | 25.6 | 46.1 | 55.3 | 1.2 | 49.3 | 18.5 |
| AS23□1F-N02-11SD | 3/8" | | | 17.9 | | | | | 38.7 | | | | | | |
| AS33□1F-N02-07SD | 1/4" | | | 13.2 | | | | | 37.9 | | | | | | |
| AS33□1F-N02-09SD | 5/16" | | | 15.2 | | | | | 39.7 | | | | | | |
| AS33□1F-N02-11SD | 3/8" | NPT 3/8 | 19 | 17.9 | 23 | 12.9 | 9.8 | 20.6 | 43.7 | 32.6 | 56.2 | 53.7 | 1.2 | 47.4 | 21 |
| AS33□1F-N03-07SD | 1/4" | | | 13.2 | | | | | 38.7 | | | | | | |
| AS33□1F-N03-09SD | 5/16" | | | 15.2 | | | | | 39.7 | | | | | | |
| AS33□1F-N03-11SD | 3/8" | | | 17.9 | | | | | 43.7 | | | | | | |
| AS43□1F-N04-10SD | 3/8" | NPT 1/2 | 23.8 | 17.9 | 29 | 16.2 | 12.4 | 25.8 | 49.4 | 32.6 | 55.3 | 63.8 | 1.2 | 55.8 | 21 |
| AS43□1F-N04-13SD | 1/2" | | | 21.7 | | | | | 26.8 | | | | | | |

* Reference dimensions of 10-32 UNF and NPT threads after installation.

Speed Controller Adjustable by Flat Head Screwdriver with One-touch Fittings

Series AS□□□1F-D

In-line Type



Model

| Model | Applicable tubing O.D. | | | | | | | | | | | | Applicable cylinder bore size (mm) | |
|---------|------------------------|---|---|---|----|----|-----------|-------|-------|------|-------|------|------------------------------------|----------------|
| | Metric size | | | | | | Inch size | | | | | | | |
| | 3.2 | 4 | 6 | 8 | 10 | 12 | 1/8" | 5/32" | 3/16" | 1/4" | 5/16" | 3/8" | | 1/2" |
| AS1001F | ● | ● | ● | | | | ● | ● | ● | ● | | | | 6, 10, 16, 20 |
| AS2001F | | ● | ● | | | | | ● | ● | ● | | | | 20, 25, 32 |
| AS2051F | | | ● | ● | | | | | ● | ● | ● | | | 20, 25, 32, 40 |
| AS3001F | | | ● | ● | ● | ● | | | | ● | ● | ● | | 40, 50, 63 |
| AS4001F | | | | | ● | ● | | | | | | ● | ● | 63, 80, 100 |

Specifications

| | |
|--------------------------------|---------------------------------|
| Fluid | Air |
| Proof pressure | 1.5 MPa |
| Max. operating pressure | 1 MPa |
| Min. operating pressure | 0.1 MPa |
| Ambient and fluid temperature | -5 to 60°C (No freezing) |
| Number of needle rotations | 10 turns (8 turns (1)) |
| Applicable tubing material (2) | Nylon, Soft nylon, Polyurethane |

Note 1) In the case of AS1001F type

Note 2) Use caution regarding the max. operating pressure when soft nylon or polyurethane tubing is used. (Refer to pages 15-6-3 to 15-6-5 for details.)

JIS Symbol

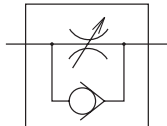

Flow Rate and Effective Area

| Model | AS1001F | AS2001F | AS2051F | AS3001F | AS4001F | | | | | | |
|-----------------------------|-----------------------------------|------------------------------|---------|---------------|---------|---------------|-------|--------|----------|-------|-------|
| Tubing O.D. | Metric size | ø3.2, ø4, ø6 | ø4 | ø6 | ø6 | ø8 | ø6 | ø8 | ø10, ø12 | ø10 | ø12 |
| | Inch size | ø1/8", ø5/32", ø3/16", ø1/4" | ø5/32" | ø3/16", ø1/4" | ø3/16" | ø1/4", ø5/16" | ø1/4" | ø5/16" | ø3/8" | ø3/8" | ø1/2" |
| Controlled flow (Free flow) | Flow rate (l/min (ANR)) | 100 | 130 | 230 | 290 | 460 | 660 | 920 | 1050 | 1390 | |
| | Effective area (mm ²) | 1.5 | 2 | 3.5 | 4.5 | 7 | 6.5 | 10 | 14 | 16 | 21 |

Note) Flow rate values are measured at 0.5 MPa and 20°C

Flow Direction Symbols on Body

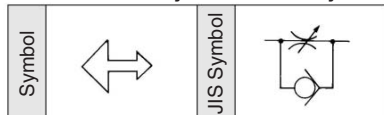

How to Order

AS 200 1F — 06 D

Body size

| | |
|-----|--------------|
| 100 | M5 standard |
| 200 | 1/8 standard |
| 205 | 1/4 standard |
| 300 | 3/8 standard |
| 400 | 1/2 standard |

With One-touch fittings

Type adjustable by flat head screwdriver

Applicable tubing O.D.

| Metric size | Inch size |
|-------------|-----------|
| 23 | ø3.2" |
| 04 | ø4 |
| 06 | ø6 |
| 08 | ø8 |
| 10 | ø10 |
| 12 | ø12 |
| 01 | ø1/8" |
| 03 | ø5/32" |
| 05 | ø3/16" |
| 07 | ø1/4" |
| 09 | ø5/16" |
| 11 | ø3/8" |
| 13 | ø1/2" |

* Use ø1/8" tube.

Needle Valve/Flow Characteristics

AS1001F

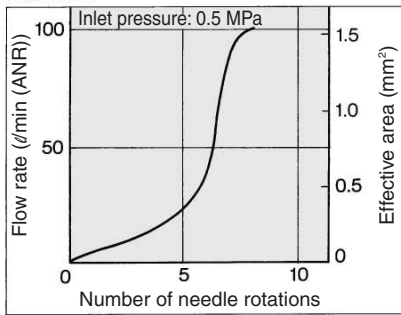

AS2001F

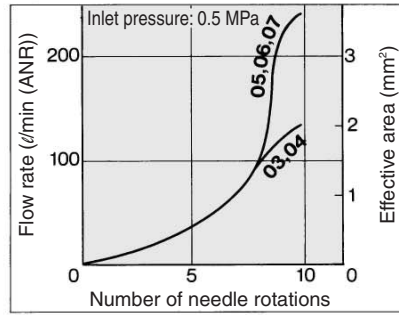

AS2051F

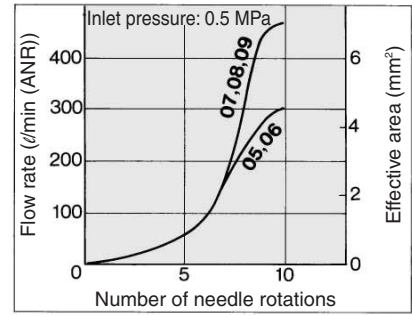

AS3001F

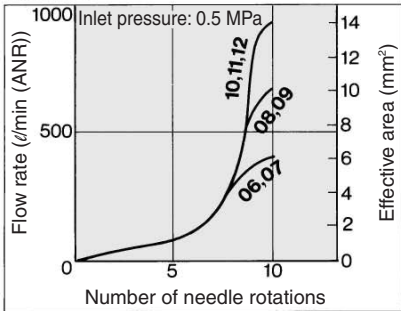

AS4001F

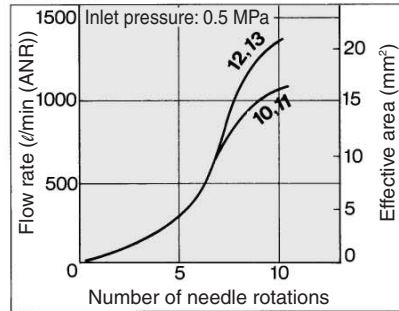

Construction

AS1001F

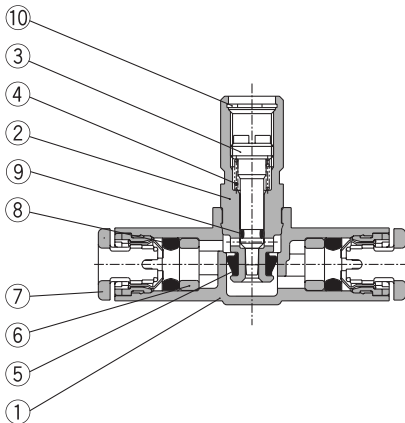

AS2001F to AS4001F

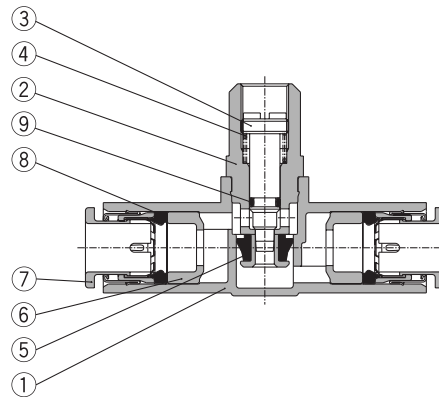

Component Parts

| No. | Description | Material | Note |
|-----|--------------------------------|-------------------------------------|---------------------------|
| ① | Body A | PBT | |
| ② | Body B | Brass | Electroless nickel plated |
| ③ | Needle | Brass | Electroless nickel plated |
| ④ | Spring | Steel wire | |
| ⑤ | U seal | HNBR | |
| ⑥ | Spacer | POM ⁽¹⁾ | |
| ⑦ | Cassette | POM, Stainless steel ⁽²⁾ | |
| ⑧ | Seal | NBR | |
| ⑨ | O-ring | NBR | |
| ⑩ | Retaining ring for hole type C | Tool steel | |

Note 1) $\phi 3/16"$, $\phi 3/8"$, $\phi 1/2"$ are made of brass (Electroless nickel plated).

Note 2) $\phi 3/16"$, $\phi 5/16"$, $\phi 3/8"$, $\phi 1/2"$ are made of POM, stainless steel, and brass (Electroless nickel plated).

Speed Controller Adjustable by Flat Head Screwdriver: Standard Type

Series AS□2□0-D

Elbow Type (Metal Body)



Model/Specifications

| Specifications | Model | AS12□0-M5 | AS12□0-U10/32 | AS22□0-□01 | AS22□0-□02 | AS32□0-□02 | AS32□0-□03 | AS42□0-□04 |
|------------------------------------|-----------------------------------|--------------------------|---------------|----------------|------------|----------------|------------|------------|
| Port size | | M5 x 0.8 | 10-32 UNF | 1/8 | 1/4 | 1/4 | 3/8 | 1/2 |
| Applicable cylinder bore size (mm) | | 6, 10, 16, 20, 25 | | 20, 25, 32, 40 | | 32, 40, 50, 63 | | 80, 100 |
| Fluid | | Air | | | | | | |
| Proof pressure | | 1.5 MPa | | | | | | |
| Max. operating pressure | | 1 MPa | | | | | | |
| Min. operating pressure | | 0.1 MPa | | | | | | |
| Ambient and fluid temperature | | -5 to 60°C (No freezing) | | | | | | |
| Number of needle rotations | | 8 turns | | 10 turns | | | | |
| Controlled flow (Free flow) | Flow rate (l/min (ANR)) | 105 | | 230 | 460 | 920 | | 1700 |
| | Effective area (mm ²) | 1.6 | | 3.5 | 7 | 14 | | 26 |

Note 1) Flow rate values are measured at 0.5 MPa and 20°C.

Note 2) Meter-out and meter-in types can be visually differentiated by the flow direction symbol on the resin body.

Note 3) Brass parts are all electroless nickel plated, provided as standard.

AS

ASP

ASN

AQ

ASV

AK

ASS

ASR

ASF

How to Order

AS 2 2 0 0-01-S D

JIS Symbol

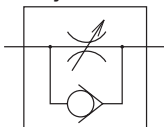

Body size

| | |
|---|-------------------|
| 1 | M5 standard |
| 2 | 1/8, 1/4 standard |
| 3 | 3/8 standard |
| 4 | 1/2 standard |

Type

| | |
|---|-------|
| 2 | Elbow |
|---|-------|

Control

| | |
|---|-----------|
| 0 | Meter-out |
| 1 | Meter-in |

Type adjustable by flat head screwdriver

With seal

Note) In case that connecting port is either M5 or 10-32 UNF thread, it is not available with seal. With gasket is provided as standard.

Port size

| Symbol | Cylinder side | In the side of solenoid valve |
|--------|---------------|-------------------------------|
| M5 | M5 x 0.8 | M5 x 0.8 |
| 01 | R 1/8 | Rc 1/8 |
| 02 | R 1/4 | Rc 1/4 |
| 03 | R 3/8 | Rc 3/8 |
| 04 | R 1/2 | Rc 1/2 |
| F01 | R 1/8 | G 1/8 |
| F02 | R 1/4 | G 1/4 |
| F03 | R 3/8 | G 3/8 |
| F04 | R 1/2 | G 1/2 |
| U10/32 | 10-32 UNF | 10-32 UNF |
| N01 | NPT 1/8 | NPT 1/8 |
| N02 | NPT 1/4 | NPT 1/4 |
| N03 | NPT 3/8 | NPT 3/8 |
| N04 | NPT 1/2 | NPT 1/2 |

Construction

Meter-out
M5 type
U10/32 port

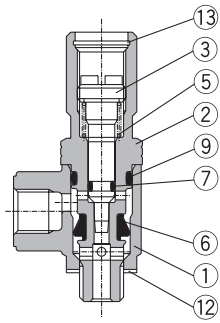

AS2200-01-D

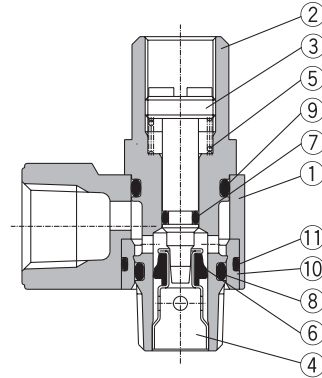

AS3200-02-D

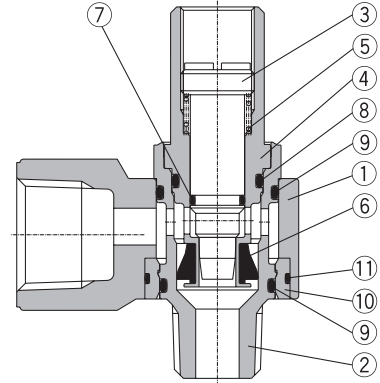

Meter-out
M5 type
U10/32 port

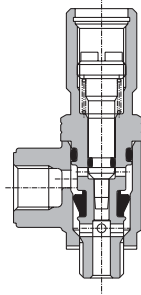

AS2210-01-D

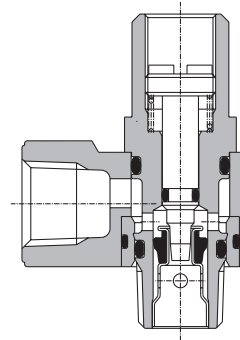

AS3210-02-D

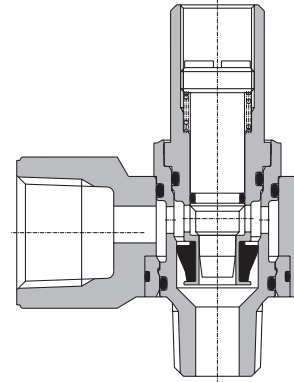

Component Parts

| No. | Description | Material | Note |
|-----|--------------------------------|----------------------|---------------------------|
| ① | Body A | Zinc alloy | |
| ② | Body B | Brass | Electroless nickel plated |
| ③ | Needle | Brass | Electroless nickel plated |
| ④ | Seat ring | Brass | Electroless nickel plated |
| ⑤ | Spring | Steel wire | |
| ⑥ | U seal | HNBR | |
| ⑦ | O-ring | NBR | |
| ⑧ | O-ring | NBR | |
| ⑨ | O-ring | NBR | |
| ⑩ | Bushing | PBT | |
| ⑪ | O-ring | NBR | |
| ⑫ | Gasket | NBR, Stainless steel | |
| ⑬ | Retaining ring for hole type C | Tool steel | |

**Speed Controller Adjustable by Flat Head Screwdriver
Standard Type, Elbow Type (Metal Body)**

Dimensions

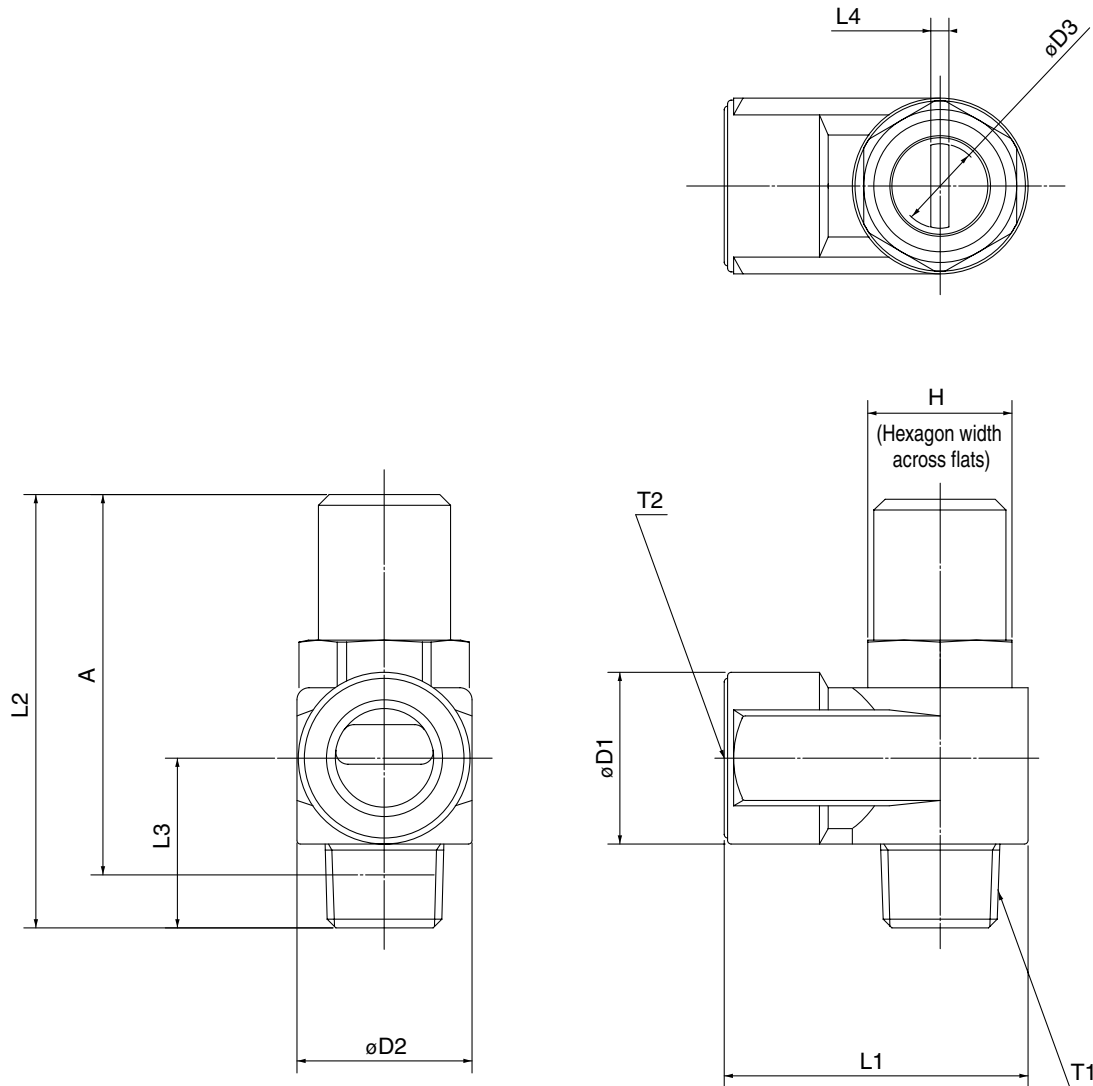

- AS
- ASP
- ASN
- AQ
- ASV
- AK
- ASS
- ASR
- ASF

Dimensions

| Model | T1 | T2 | H | D1 | D2 | D3 | L1 | L2 | L3 | L4 | A* | |
|-----------------|-----------|-----------|------|------|------|------|------|------|------|------|------|-----|
| AS12□0-M5-D | M5 x 0.8 | M5 x 0.8 | 8 | 9 | 9 | 4.7 | 10 | 31 | 10.3 | 0.7 | 27.4 | |
| AS12□0-U10/32-D | 10-32 UNF | 10-32 UNF | | | | | | | | | | |
| AS22□0-01-SD | R 1/8 | Rc 1/8 | 12 | 14.3 | 14.6 | 7.2 | 18 | 35.6 | 14.1 | 1.2 | 31.6 | |
| AS22□0-F01-SD | | G 1/8 | | | | | | | | | | |
| AS22□0-N01-SD | NPT 1/8 | NPT 1/8 | 12.7 | 18 | 19.5 | 7.2 | 27.2 | 40.7 | 18 | 1.2 | 36.7 | |
| AS22□0-02-SD | R 1/4 | Rc 1/4 | | | | | | | | | | |
| AS22□0-F02-SD | | G 1/4 | 17 | 17.5 | 19 | 22.5 | 24.3 | 9.8 | 30 | 55.3 | 22.4 | 1.2 |
| AS22□0-N02-SD | NPT 1/4 | NPT 1/4 | | | | | | | | | | |
| AS32□0-02-SD | R 1/4 | Rc 1/4 | 19 | 22.5 | 24.3 | 9.8 | 30 | 55.3 | 22.4 | 1.2 | 49.3 | |
| AS32□0-F02-SD | | G 1/4 | | | | | | | | | | |
| AS32□0-N02-SD | NPT 1/4 | NPT 1/4 | 19 | 22.5 | 24.3 | 9.8 | 30 | 53.7 | 20.8 | 1.2 | 47.4 | |
| AS32□0-03-SD | R 3/8 | Rc 3/8 | | | | | | | | | | |
| AS32□0-F03-SD | | G 3/8 | 19 | 22.5 | 24.3 | 9.8 | 30 | 53.7 | 20.8 | 1.2 | 47.4 | |
| AS32□0-N03-SD | NPT 3/8 | NPT 3/8 | | | | | | | | | | |
| AS42□0-04-SD | R 1/2 | Rc 1/2 | 24 | 27.5 | 28.5 | 12.4 | 38.5 | 63.8 | 26.7 | 1.2 | 55.8 | |
| AS42□0-F04-SD | | G 1/2 | | | | | | | | | | |
| AS42□0-N04-SD | NPT 1/2 | NPT 1/2 | 23.8 | 27.5 | 28.5 | 12.4 | 38.5 | 63.8 | 26.7 | 1.2 | 55.8 | |

* Reference thread dimensions after installation.

Flow Control Equipment Precautions



Be sure to read before handling. Refer to pages 15-18-3 to 15-18-4 for Safety Instructions and Common Precautions on the products mentioned in this catalog, and refer to main text for more detailed precautions on every series.

Precautions

Selection

Warning

1. Products mentioned in this catalog are not designed for the use as stop valve with zero air leakage.

A certain amount of leakage is allowed in the product's specifications.

Mounting

Warning

1. Check that the lock nut is tightened.
A loose lock nut may cause actuator speed changes.
2. Confirm the degree of rotation of the needle valve.
Products mentioned in this catalog are retainer type so that the needle is not removed completely. Over rotation will cause damage.
3. Do not use tools such as pliers to rotate the handle.
It can cause idle rotation of the handle or damage.
4. Confirm air flow direction.
Mounting backwards is dangerous, because the speed adjustment needle will not work and the actuator may lurch suddenly.
5. Adjust needle by opening the needle slowly after having closed it completely.
Loose needle valves may cause unexpected sudden actuator extension. When needle valve is turned clockwise, it is closed and cylinder speed decreases. When needle valve is turned counter clockwise, it is open and cylinder speed increases.
6. Do not apply excessive force or shock to the body or fittings with an impact tool.
It can cause damage or air leakage.

Series AS-F/FE/FG/FM

Selection

Warning

1. Confirm that PTFE can be used in application.

PTFE powder (Polytetrafluoroethylene resin) is included in the seal material. Confirm if the use of it may cause any adverse effect in the system.

Mounting

Warning

1. To install/remove the Flow Control Equipment, tighten/loosen at wrench flat B as close to the thread as possible using the appropriate wrench.

Do not apply torque at other points as the product may be damaged. Rotate Body A manually for positioning after installation.

2. Do not use universal type fittings for applications involving continuous rotation.

The fitting section may be damaged.

Tightening Torque

Caution

1. The tightening torque for pipe fittings is as shown in the table. As a rule, they should be tightened 2 to 3 turns with a tool after first tightening by hand.

Be careful not to cause damage by over-tightening.

| Male thread | Suitable screw torque (N·m) | Hexagon width across flats (mm) | Adjustable spanner nominal (mm) |
|-----------------|-----------------------------------|---------------------------------|---------------------------------|
| M3 | 1/4 | 4.5 | — |
| M5 10/32-UNF | 1/6 turn after hand tightening | 8 | 100 |
| 1/8 | 7 to 9 | 14 | 150 |
| 1/4 | 12 to 14 | 17 | 200 |
| 3/8 | 22 to 24 | 21 | 200 |
| 1/2 | 28 to 30 | 24 | 200 |

Lock Nut Tightening Torque

Caution

1. Suitable screw torque for a hexagon lock nut is shown in the table below. For standard installation, turn 15 to 30° using tool, after fastening by hand. Pay attention not to over torque the product.

| Body size | Suitable screw torque (N·m) |
|-----------|-----------------------------|
| M3 | 0.07 |
| M5 | 0.3 |
| 1/8 | 1 |
| 1/4 | 1.5 |
| 3/8 | 4 |
| 1/2 | 10 |

⚠ Precautions

Handling of One-touch Fittings

⚠ Caution

1. Refer to page 15-1-11 for One-touch Fitting.

Series ASD

Operation

⚠ Caution

1. Single acting cylinder

When controlling a single acting cylinder, the cylinder's return speed will differ depending on the operating conditions. Operate after confirming the maximum return speeds shown in the table below.

| Speed Controller | Cylinder | Solenoid valve | Tubing | Silencer | Maximum return speed (mm/s) | | |
|------------------|----------|----------------|---------------|----------|-----------------------------|-----|-----|
| | | | | | 100 | 200 | 300 |
| ASD230F | CJ2 | VJ500 | TU0604 1 m | AN110-01 | Cylinder size | | |
| | | | | | ø6 | | |
| | | | | | ø10 | ø16 | ø20 |
| ASD330F | CM2 | VZ500 | TU0604 1 m | AN110-01 | Cylinder size | | |
| | | | | | ø25 | | |
| | | | | | ø32 | ø25 | ø20 |

- <Operating conditions>
- Cylinder extension speed: 100 mm/s
 - Meter-out needle fully open

* Values at 0.5 MPa and 20°C.

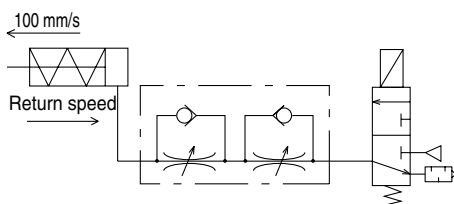

(Reference) Recommended circuit for high return speed

When low extension speed and high return speed are desired, the following circuit using 3-port is recommended.

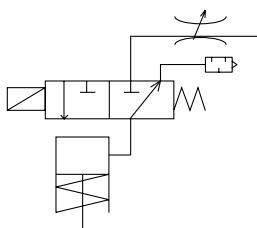

Note) Use Series AS-F with -X214 for the throttle valve.

Series ASN2

Selection

⚠ Warning

1. Inappropriate Circuits

(a) "Perfect Valve"
(VF66□□, VS7-6-FPG, VS7-8-FPG)

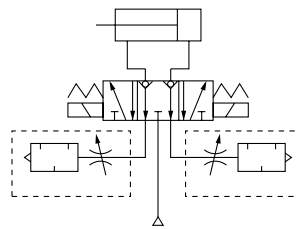

Residual pressure behind the exhaust needle may cause check valve malfunction in the "Perfect Valve".

(b) Pilot check valve between Actuator and Valve

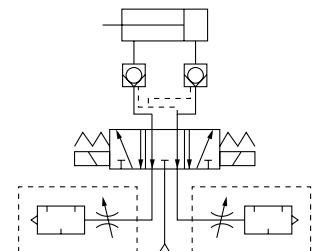

Residual pressure behind the exhaust needle may cause check valve to malfunction.

Mounting

⚠ Caution

1. If installing flow controls to valve ports, interference may occur with the fittings. Please consult the catalog before installing.

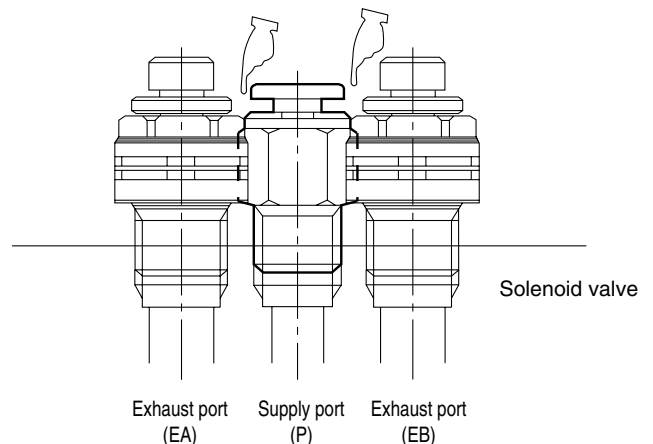

Fig. Example of the interference with fittings

Series AK

⚠ Caution

1. Vibrations may generate due to operating conditions, etc., even if the specifications are in the range mentioned in the catalog. Please consult with SMC.

2. Cracking pressure is a pressure at which the valve starts opening and not a pressure at which the valve is fully open.

⚠ Precautions

Series ASS

Selection

⚠ Warning

1. **Use meter-out controlling type after confirming the initial speed to prevent sudden actuator extension.**

Due to its specifications, the extension preventing function does not have speed control capability so that adjustments are limited. Use the meter-in controlling type if desired speed is less than set speed.

2. **Circuit pressure remaining in cylinder is not usable.**

Extension prevention works when pressure has been exhausted in cylinder. Therefore, prevent the extension by meter-in control using a speed controller in such a case.

Mounting

⚠ Warning

1. **Install Actuator and SSC valve as close as possible.**

Extensions prevention in the initial operation and standard speed control may not function.

2. **Do not use for relatively small capacity actuators. i.e. short stroke cylinders (less than 100 mm), rotary actuators, etc.**

SSC valve may not properly operate.

3. **Use in load factor less than 50%.**

Speed control under normal operations may not function.

Series AQ

Operation

⚠ Caution

1. **In the following cases, insufficient exhaust or vibration may cause noise.**

- a) With residual pressure or back pressure on the IN side
- b) When the differential pressure between the IN and OUT sides is smaller than the min. operating pressure.

Series ASP

Caution on Design

⚠ Warning

1. **This product cannot be used for accurate and precise intermediate stops of the actuator.**

Due to the compressibility of air as a fluid, the actuator will continue to move until it reaches a position of pressure balance, even though the pilot check valve closes with an intermediate stop signal.

2. **This product cannot be used to hold a stop position for an extended period of time.**

Pilot check valves and actuators are not guaranteed for zero air leakage. Therefore, it is sometimes not possible to hold a stop position for an extended period of time. In the event that holding for an extended time is necessary, a mechanical means for holding should be devised.

3. **Consider the release of residual pressure.**

Actuators may move suddenly due to residual pressure, which can be dangerous during maintenance procedures.

Selection

⚠ Warning

1. **When used in a balance control circuit, there are instances in which the check valve cannot release, even though the pilot pressure is 50% of the operating pressure. In these cases, the pilot pressure should be the same as the operating pressure.**

2. **For reference, SMC has conducted endurance tests in which ON, OFF operation of the check valve was performed at the maximum operating pressure, with a confirmed endurance of 10 million operations. Since the tests were performed under limited conditions, use caution in evaluating the results.**



Safety Instructions

These safety instructions are intended to prevent a hazardous situation and/or equipment damage. These instructions indicate the level of potential hazard by labels of "Caution", "Warning" or "Danger". To ensure safety, be sure to observe ISO 4414 ^{Note 1)}, JIS B 8370 ^{Note 2)} and other safety practices.

 **Caution** : Operator error could result in injury or equipment damage.

 **Warning** : Operator error could result in serious injury or loss of life.

 **Danger** : In extreme conditions, there is a possible result of serious injury or loss of life.

Note 1) ISO 4414: Pneumatic fluid power--General rules relating to systems.

Note 2) JIS B 8370: General Rules for Pneumatic Equipment

Warning

1. The compatibility of pneumatic equipment is the responsibility of the person who designs the pneumatic system or decides its specifications.

Since the products specified here are used in various operating conditions, their compatibility for the specific pneumatic system must be based on specifications or after analysis and/or tests to meet your specific requirements. The expected performance and safety assurance will be the responsibility of the person who has determined the compatibility of the system. This person should continuously review the suitability of all items specified, referring to the latest catalog information with a view to giving due consideration to any possibility of equipment failure when configuring a system.

2. Only trained personnel should operate pneumatically operated machinery and equipment.

Compressed air can be dangerous if an operator is unfamiliar with it. Assembly, handling or repair of pneumatic systems should be performed by trained and experienced operators.

3. Do not service machinery/equipment or attempt to remove components until safety is confirmed.

1. Inspection and maintenance of machinery/equipment should only be performed once measures to prevent falling or runaway of the driver objects have been confirmed.
2. When equipment is to be removed, confirm the safety process as mentioned above. Cut the supply pressure for this equipment and exhaust all residual compressed air in the system.
3. Before machinery/equipment is restarted, take measures to prevent shooting-out of cylinder piston rod, etc.

4. Contact SMC if the product is to be used in any of the following conditions:

1. Conditions and environments beyond the given specifications, or if product is used outdoors.
2. Installation on equipment in conjunction with atomic energy, railway, air navigation, vehicles, medical equipment, food and beverages, recreation equipment, emergency stop circuits, clutch and brake circuits in press applications, or safety equipment.
3. An application which has the possibility of having negative effects on people, property, or animals, requiring special safety analysis.



Common Precautions

Be sure to read before handling.

For detailed precautions on every series, refer to main text.

Selection

Warning

1. Confirm the specifications.

Products represented in this catalog are designed for use in compressed air applications only (including vacuum), unless otherwise indicated.

Do not use the product outside their design parameters.

Please contact SMC when using the products in applications other than compressed air (including vacuum).

Mounting

Warning

1. Instruction manual

Install the products and operate them only after reading the instruction manual carefully and understanding its contents. Also keep the manual where it can be referred to as necessary.

2. Securing the space for maintenance

When installing the products, please allow access for maintenance.

3. Tightening torque

When installing the products, please follow the listed torque specifications.

Piping

Caution

1. Before piping

Make sure that all debris, cutting oil, dust, etc. are removed from the piping.

2. Wrapping of pipe tape

When screwing piping or fittings into ports, ensure that chips from the pipe threads or sealing material do not get inside the piping. Also, when the pipe tape is used, leave 1.5 to 2 thread ridges exposed at the end of the threads.

Air Supply

Warning

1. Operating fluid

Please consult with SMC when using the product in applications other than compressed air (including vacuum).

Regarding products for general fluid, please ask SMC about applicable fluids.

2. Install an air dryer, aftercooler, etc.

Excessive condensate in a compressed air system may cause valves and other pneumatic equipment to malfunction.

Installation of an air dryer, after cooler etc. is recommended.

3. Drain flushing

If condensate in the drain bowl is not emptied on a regular basis, the bowl will over flow and allow the condensate to enter the compressed air lines.

If the drain bowl is difficult to check and remove, it is recommended that a drain bowl with the auto-drain option be installed.

For compressed air quality, refer to "Air Preparation Equipment" catalog.

4. Use clean air

If the compressed air supply is contaminated with chemicals, synthetic materials, corrosive gas, etc., it may lead to break down or malfunction.

Operating Environment

Warning

1. Do not use in environments where the product is directly exposed to corrosive gases, chemicals, salt water, water or steam.

2. Do not expose the product to direct sunlight for an extended period of time.

3. Do not use in a place subject to heavy vibrations and/or shocks.

4. Do not mount the product in locations where it is exposed to radiant heat.

Maintenance

Warning

1. Maintenance procedures are outlined in the operation manual.

Not following proper procedures could cause the product to malfunction and could lead to damage to the equipment or machine.

2. Maintenance work

If handled improperly, compressed air can be dangerous.

Assembly, handling and repair of pneumatic systems should be performed by qualified personnel only.

3. Drain flushing

Remove drainage from air filters regularly. (Refer to the specifications.)

4. Shut-down before maintenance

Before attempting any kind of maintenance make sure the supply pressure is shut of and all residual air pressure is released from the system to be worked on.

5. Start-up after maintenance and inspection

Apply operating pressure and power to the equipment and check for proper operation and possible air leaks. If operation is abnormal, please verify product set-up parameters.

6. Do not make any modifications to be product.

Do not take the product apart.

Quality Assurance Information (ISO 9001, ISO 14001)

Reliable quality of products in the global market

To enable our customers throughout the world to use our products with even greater confidence, SMC has obtained certification for international standards “ISO 9001” and “ISO 14001”, and created a complete structure for quality assurance and environmental controls. SMC products pursue to meet its customers’ expectations while also considering company’s contribution in society.

Quality management system ISO 9001

This is an international standard for quality control and quality assurance. SMC has obtained a large number of certifications in Japan and overseas, providing assurance to our customers throughout the world.



Environmental management system ISO 14001

This is an international standard related to environmental management systems and environmental inspections. While promoting environmentally friendly automation technology, SMC is also making diligent efforts to preserve the environment.



SMC’s quality control system



Quality policies



Quality control activities

SMC Product Conforming to Inter

SMC products complying with EN/ISO, CSA/UL standards are supporting



The CE mark indicates that machines and components meet essential requirements of all the EC Directives applied.

It has been obligatory to apply CE marks indicating conformity with EC Directives when machines and components are exported to the member Nations of the EU.

Once "A manufacturer himself" declares a product to be safe by means of CE marking (declaration of conformity by manufacturer), free distribution inside the member Nations of the EU is permissible.

■ CE Mark

SMC provides CE marking to products to which EMC and Low Voltage Directives have been applied, in accordance with CETOP (European hydraulics and pneumatics committee) guide lines.

■ As of February 1998, the following 18 countries will be obliged to conform to CE mark legislation

Iceland, Ireland, United Kingdom, Italy, Austria, Netherlands, Greece, Liechtenstein, Sweden, Spain, Denmark, Germany, Norway, Finland, France, Belgium, Portugal, Luxembourg

■ EC Directives and Pneumatic Components

• Machinery Directive

The Machinery Directive contains essential health and safety requirements for machinery, as applied to industrial machines e.g. machine tools, injection molding machines and automatic machines. Pneumatic equipment is not specified in Machinery Directive. However, the use of SMC products that are certified as conforming to EN Standards, allows customers to simplify preparation work of the Technical Construction File required for a Declaration of Conformity.

• Electromagnetic Compatibility (EMC) Directive

The EMC Directive specifies electromagnetic compatibility. Equipment which may generate electromagnetic interference or whose function may be compromised by electromagnetic interference is required to be immune to electromagnetic affects (EMS/immunity) without emitting excessive electromagnetic affects (EMI/emission).

• Low Voltage Directive

This directive is applied to products, which operate above 50 VAC to 1000 VAC and 75 VDC to 1500 VDC operating voltage, and require electrical safety measures to be introduced.

• Simple Pressure Vessels Directive

This directive is applied to welded vessels whose maximum operating pressure (PS) and volume of vessel (V) exceed 50 bar/L. Such vessels require EC type examination and then CE marking.

national Standards

you to comply with EC directives and CSA/UL standards.



■ CSA Standards & UL Standards

UL and CSA standards have been applied in North America (U.S.A. and Canada) symbolizing safety of electric products, and are defined to mainly prevent danger from electric shock or fire, resulting from trouble with electric products. Both UL and CSA standards are acknowledged in North America as the first class certifying body. They have a long experience and ability for issuing product safety certificate. Products approved by CSA or UL standards are accepted in most states and governments beyond question.

Since CSA is a test certifying body as the National Recognized Testing Laboratory (NRTL) within the jurisdiction of Occupational Safety and Health Administration (OSHA), SMC was tested for compliance with CSA Standards and UL Standards at the same time and was approved for compliance with the two Standards. The above CSA NRTL/C logo is described on a product label in order to indicate that the product is approved by CSA and UL Standards.

■ TSSA (MCCR) Registration Products

TSSA is the regulation in Ontario State, Canada. The products that the operating pressure is more than 5 psi (0.03 MPa) and the piping size is bigger than 1 inch. fall into the scope of TSSA regulation.

Products conforming to CE Standard



With CE symbol for simple visual recognition

In this catalog each accredited product series is indicated with a CE mark symbol. However, in some cases, every available models may not meet CE compliance. Please visit our web site for the latest selection of available models with CE mark.

<http://www.smcworld.com>

SMC's Global Service Network

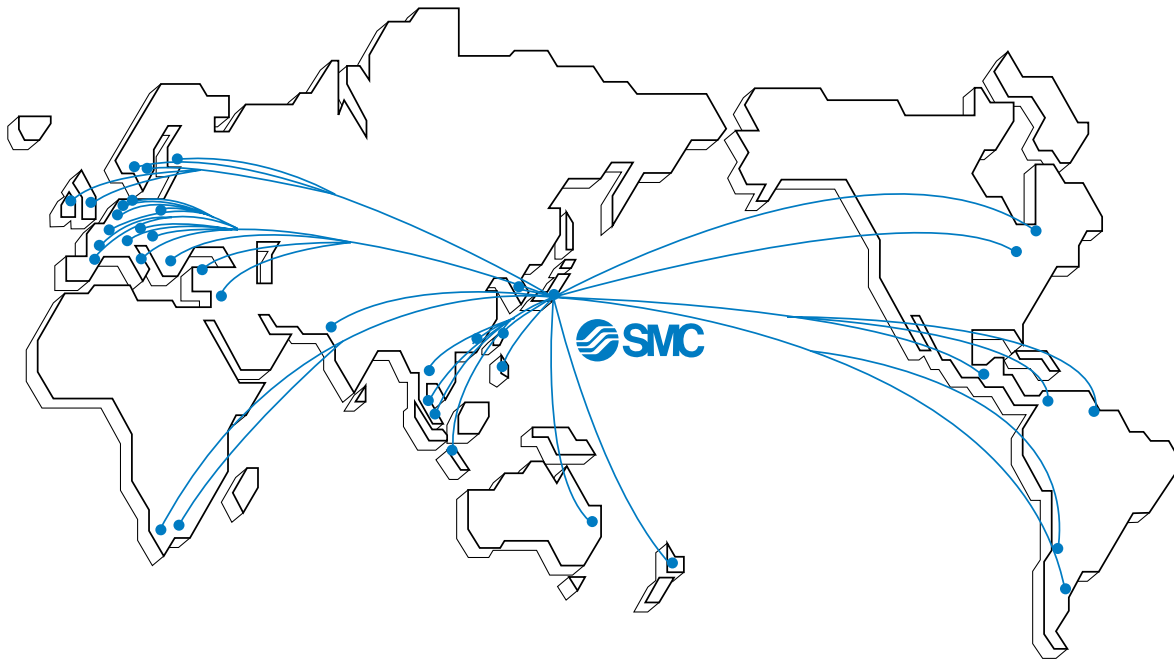

America

U.S.A. **SMC Corporation of America**

3011 North Franklin Road Indianapolis, IN 46226, U.S.A.
TEL: 317-899-4440 FAX: 317-899-3102

CANADA **SMC Pneumatics (Canada) Ltd.**

6768 Financial Drive Mississauga, Ontario, L5N 7J6 Canada
TEL: 905-812-0400 FAX: 905-812-8686

MEXICO **SMC Corporation (Mexico), S.A. DE C.V.**

Carr. Silao-Trejo K.M. 2.5 S/N, Predio San Jose del Duranzo
C.P. 36100, Silao, Gto., Mexico
TEL: 472-72-2-55-00 FAX: 472-72-2-59-44/2-59-46

CHILE **SMC Pneumatics (Chile) S.A.**

Av. La Montaña 1,115 km. 16,5 P. Norte Parque
Industrial Valle Grande, Lampa Santiago, Chile
TEL: 02-270-8600 FAX: 02-270-8601

ARGENTINA **SMC Argentina S.A.**

Teodoro Garcia 3860 (1427) Buenos Aires, Argentina
TEL: 011-4555-5762 FAX: 011-4555-5762

BOLIVIA **SMC Pneumatics Bolivia S.R.L.**

Avenida Beni Numero 4665
Santa Cruz de la Sierra-Casilla de Correo 2281, Bolivia
TEL: 591-3-3428383 FAX: 591-3-3449900

VENEZUELA **SMC Neumatica Venezuela S.A.**

Apartado 40152, Avenida Nueva Granada, Edificio Wanlac,
Local 5, Caracas 1040-A, Venezuela
TEL: 2-632-1310 FAX: 2-632-3871

PERU (Distributor) **IMPECO Automatizacion Industrial S.A.**

AV. Canevaro 752, Lince, Lima, Peru
TEL: 1-471-6002 FAX: 1-471-0935

URUGUAY (Distributor) **BAKO S.A.**

Galicia 1650 esq. Gaboto C.P. 11200, Montevideo, Uruguay
TEL: 2-401-6603 FAX: 2-409-4306

BRAZIL **SMC Pneumaticos Do Brasil Ltda.**

Rua. Dra. Maria Fidelis, nr. 130, Jardim Piraporinha-Diadema-S.P.
CEP: 09950-350, Brasil
TEL: 11-4051-1177 FAX: 11-4071-6636

COLOMBIA (Distributor) **Airmatic Ltda.**

Calle 18 69-05 Apart. Aereo 081045 Santa Fe de Bogotá, Colombia
TEL: 1-424-9240 FAX: 1-424-9260

Europe

U.K. **SMC Pneumatics (U.K.) Ltd.**

Vincent Avenue, Crownhill, Milton Keynes, MK8 0AN, Buckinghamshire, U.K.
TEL: 01908-563888 FAX: 01908-561185

GERMANY **SMC Pneumatik GmbH**

Boschring 13-15 D-63329 Egelsbach, Germany
TEL: 06103-4020 FAX: 06103-402139

ITALY **SMC Italia S.p.A.**

Via Garibaldi 62 I-20061 Carugate Milano, Italy
TEL: 02-9271365 FAX: 02-9271365

FRANCE **SMC Pneumatique S.A.**

1 Boulevard de Strasbourg, Parc Gustave Eiffel, Bussy Saint Georges, F-77600
Marne La Vallee Cedex 3 France
TEL: 01-64-76-10-00 FAX: 01-64-76-10-10

SWEDEN **SMC Pneumatics Sweden AB**

Ekhagsvägen 29-31, S-141 05 Huddinge, Sweden
TEL: 08-603-07-00 FAX: 08-603-07-10

SWITZERLAND **SMC Pneumatik AG**

Dorfstrasse 7, Postfach 117, CH-8484 Weisslingen, Switzerland
TEL: 052-396-3131 FAX: 052-396-3191

AUSTRIA **SMC Pneumatik GmbH (Austria)**

Girakstrasse 8, A-2100 Korneuburg, Austria
TEL: 0-2262-6228-0 FAX: 0-2262-62285

SPAIN **SMC España, S.A.**

Zuazobidea 14 Pol. Ind. Júndiz 01015 Vitoria, Spain
TEL: 945-184-100 FAX: 945-184-510

IRELAND **SMC Pneumatics (Ireland) Ltd.**

2002 Citywest Business Campus, Naas Road, Saggart, Co. Dublin, Ireland
TEL: 01-403-9000 FAX: 01-466-0385

NETHERLANDS (Associated company) **SMC Pneumatics BV**

De Ruyterkade 120, NL-1011 AB Amsterdam, Netherlands
TEL: 020-5318888 FAX: 020-5318880

GREECE (Distributor) **S.Parianopoulos S.A.**

7, Konstantinoupoleos Street 11855 Athens, Greece
TEL: 01-3426076 FAX: 01-3455578

DENMARK **SMC Pneumatik A/S**

Knudsminde 4 B DK-8300
Odder, Denmark
TEL: 70252900 FAX: 70252901

Europe

FINLAND **SMC Pneumatics Finland OY**

PL72, Tiistinniityntie 4, SF-02231 ESP00, Finland
TEL: 09-8595-80 FAX: 09-8595-8595

NORWAY **SMC Pneumatics Norway A/S**

Vollsveien 13C, Granfoss Næringspark N-1366 LYSAKER, Norway
TEL: 67-12-90-20 FAX: 67-12-90-21

BELGIUM (Distributor) **SMC Pneumatics N.V./S.A.**

Nijverheidsstraat 20 B-2160 Wommelgem Belguim
TEL: 03-355-1464 FAX: 03-355-1466

POLAND **SMC Industrial Automation Polska Sp.z.o.o.**

ul. Konstruktorska 11A, PL-02-673 Warszawa, Poland
TEL: 022-548-5085 FAX: 022-548-5087

TURKEY (Distributor) **Entek Pnömatik San.ve Tic. Ltd. Sti**

Perpa Tic. Merkezi Kat:11 No.1625 80270 Okmeydani Istanbul, Türkiye
TEL: 0212-221-1512 FAX: 0212-221-1519

RUSSIA **SMC Pneumatik LLC.**

36/40 Sredny prospect V.O. St. Petersburg 199004, Russia
TEL: 812-118-5445 FAX: 812-118-5449

CZECH **SMC Industrial Automation CZ s.r.o.**

Hudcova 78a, CZ-61200 Brno, Czech Republic
TEL: 05-4121-8034 FAX: 05-4121-8034

HUNGARY **SMC Hungary Ipari Automatizálási kft.**

Budafoki ut 107-113 1117 Budapest
TEL: 01-371-1343 FAX: 01-371-1344

ROMANIA **SMC Romania S.r.l.**

Str. Frunzei, Nr. 29, Sector 2, Bucharest, Romania
TEL: 01-3205111 FAX: 01-3261489

SLOVAKIA **SMC Priemyselná automatizácia, s.r.o.**

Nova 3, SK-83103 Bratislava
TEL: 02-4445-6725 FAX: 02-4445-6028

SLOVENIA **SMC Industrijska Avtomatila d.o.o.**

Grajski trg 15, SLO- 8360 Zuzemberk, Slovenia
TEL: 07388-5240 FAX: 07388-5249

LATVIA **SMC Pneumatics Latvia SIA**

Šmerļa ielā 1-705, Rīga LV-1006
TEL: 777 94 74 FAX: 777 94 75

SOUTH AFRICA (Distributor) **Hyflo Southern Africa (Pty.) Ltd.**

P.O.Box 240 Paardeneiland 7420 South Africa
TEL: 021-511-7021 FAX: 021-511-4456

EGYPT (Distributor) **Saadani Trading & Ind. Services**

15 Sebaai Street, Miami 21411 Alexandria, Egypt
TEL: 3-548-50-34 FAX: 3-548-50-34

Oceania/Asia

AUSTRALIA **SMC Pneumatics (Australia) Pty.Ltd.**

14-18 Hudson Avenue Castle Hill NSW 2154, Australia
TEL: 02-9354-8222 FAX: 02-9894-5719

NEW ZEALAND **SMC Pneumatics (New Zealand) Ltd.**

8C Sylvia Park Road Mt.Wellington Auckland, New Zealand
TEL: 09-573-7007 FAX: 09-573-7002

TAIWAN **SMC Pneumatics (Taiwan) Co.,Ltd.**

17, Lane 205, Nansan Rd., Sec.2, Luzhu-Hsiang, Taoyuan-Hsien, TAIWAN
TEL: 03-322-3443 FAX: 03-322-3387

HONG KONG **SMC Pneumatics (Hong Kong) Ltd.**

29/F, Clifford Centre, 778-784 Cheung, Sha Wan Road, Lai Chi Kok, Kowloon, Hong Kong
TEL: 2744-0121 FAX: 2785-1314

SINGAPORE **SMC Pneumatics (S.E.A.) Pte. Ltd.**

89 Tuas Avenue 1, Jurong Singapore 639520
TEL: 6861-0888 FAX: 6861-1889

PHILIPPINES **SHOKETSU SMC Corporation**

Unit 201 Common Goal Tower, Madrigal Business Park, Ayala Alabang Muntinlupa, Philippines
TEL: 02-8090565 FAX: 02-8090586

MALAYSIA **SMC Pneumatics (S.E.A.) Sdn. Bhd.**

Lot 36 Jalan Delima1/1, Subang Hi-Tech Industrial Park, Batu 3 40000 Shah Alam Selangor, Malaysia
TEL: 03-56350590 FAX: 03-56350602

SOUTH KOREA **SMC Pneumatics Korea Co., Ltd.**

Woolim e-BIZ Center (Room 1008), 170-5, Guro-Dong, Guro-Gu, Seoul, 152-050, South Korea
TEL: 02-3219-0700 FAX: 02-3219-0702

CHINA **SMC (China) Co., Ltd.**

7 Wan Yuan St. Beijing Economic & Technological Development Zone 100176, China
TEL: 010-67882111 FAX: 010-67881837

THAILAND **SMC Thailand Ltd.**

134/6 Moo 5, Tiwanon Road, Bangkadi, Amphur Muang, Patumthani 12000, Thailand
TEL: 02-963-7099 FAX: 02-501-2937

INDIA **SMC Pneumatics (India) Pvt. Ltd.**

D-107 to 112, Phase-2, Extension, Noida, Dist. Gautaim Budh Nagar, U.P. 201 305, India
TEL: (0120)-4568730 FAX: 0120-4568933

INDONESIA (Distributor) **P.T. Riyadi Putera Makmur**

Jalan Hayam Wuruk Komplek Glodok Jaya No. 27-28 Jakarta 11180 Indonesia
TEL: 021-625 5548 FAX: 021-625 5888

PAKISTAN (Distributor) **Jubilee Corporation**

First Floor Mercantile Centre, Newton Road Near Boulton Market P.O. Box 6165 Karachi 74000 Pakistan
TEL: 021-243-9070/8449 FAX: 021-241-4589

ISRAEL (Distributor) **Baccara Automation Control**

Kvutza Geva 18915 Israel
TEL: 04-653-5960 FAX: 04-653-1445

SAUDI ARABIA (Distributor) **Assaggaff Trading Est.**

P.O. Box 3385 Al-Amir Majed Street, Jeddah-21471, Saudi Arabia
TEL: 02-6761574 FAX: 02-6708173