

# Series 10-21-AF Air filter

## How to Order

Clean series

10-AF 30-F 03 B J

21-AF 30-F 03 B J

\* "J" must always be selected.

Copper, fluorine and silicon-free + Low particle generation

Air filter

Body size

20 30 40 50 60

Thread type

Nil	Rc
N Note 1)	NPT
F Note 2)	G

Port size

Symbol	Port size	Body size				
		20	30	40	50	60
01	1/8	●	—	—	—	—
02	1/4	●	●	●	—	—
03	3/8	—	●	●	—	—
04	1/2	—	—	●	—	—
06	3/4	—	—	●	●	—
10	1	—	—	—	●	●

Accessory

Symbol	Description	Applicable model
Nil	—	—
B Note 3)	With bracket	20 to 60

Note 3) Bracket is not assembled and is supplied loose at the time of shipment.

Option

Symbol	Description	Applicable model
2	Metal bowl	20 to 60
6	Nylon bowl	20 to 60
8	Metal bowl with level gauge	30 to 60
C	With bowl guard	20
J Note 4)	Drain guide 1/8	20
	Drain guide 1/4	30 to 60
R	Flow direction: Right to left	20 to 60
Z Note 5)	Name plate and caution plate for bowl in imperial units (PSI, °F)	20 to 60

Note 1) Drain guide is NPT 1/8 (applicable to size 20), and NPT 1/4 (applicable to size 30 to 60).

Note 2) Drain guide is G 1/8 (applicable to size 20), and G 1/4 (applicable to size 30 to 60).

Note 3) Bracket is not assembled and is supplied loose at the time of shipment.

Note 4) Without a valve function.

Note 5) For NPT thread type. This product is for overseas use only according to the new Measurement Law. (The SI unit type is provided for use in Japan).



## Accessory/Optional specifications combinations

⊙Combination available    ⊠Combination not available  
○Varies depending on the model    △Available only with NPT thread

Combination	Symbol	Accessory	Optional specifications							Applicable filter	
			B	2	6	8	C	J	R	Z	10-/21-AF20
Accessory/Optional specifications											
With bracket	B	⊙	⊙	⊙	○	○	⊙	⊙	△	⊙	⊙
Metal bowl	-2	⊙	⊙	⊙	⊙	⊙	⊙	⊙	△	⊙	⊙
Nylon bowl	-6	⊙	⊙	⊙	⊙	○	○	⊙	△	⊙	⊙
Metal bowl with level gauge	-8	⊙	⊙	⊙	⊙	⊙	⊙	⊙	△	⊙	⊙
With bowl guard	-C	⊙	⊙	⊙	⊙	⊙	⊙	⊙	△	⊙	⊙
Drain guide	-J	⊙	⊙	⊙	○	○	⊙	⊙	△	⊙	⊙
Flow direction: Right to left	-R	⊙	⊙	⊙	○	○	⊙	⊙	△	⊙	⊙
Name plate and caution plate for bowl in imperial units (PSI, °F)	-Z	△	△	△	△	△	△	△	△	△	△

## Standard specifications

Model	10-/21-AF20	10-/21-AF30	10-/21-AF40	10-/21-AF40-06	10-/21-AF50	10-/21-AF60
Port size	1/8, 1/4	1/4, 3/8	1/4, 3/8, 1/2	3/4	3/4, 1	1
Fluid	Air					
Proof pressure	1.5 MPa					
Maximum operating pressure	1.0 MPa					
Ambient & fluid temperature	-5 to 60°C (No freezing)					
Nominal filtration rating	5 μm					
Air flow capacity Note 6) (ℓ/min (ANR))	800 (1/8) 1000 (1/4)	1600 (1/4) 2100 (3/8)	1600 (1/4) 2800 (3/8) 3700 (1/2)	4200 (3/4)	6100 (3/4) 7000 (1)	8200 (1)
Drain capacity (cm <sup>3</sup> )	8	25	45	45	45	45
Drain guide port size	1/8	1/4	1/4	1/4	1/4	1/4
Grease	10-: Fluorine grease 21-: Lithium soap based grease					
Particle generation grade (Refer to front matter pages 13 to 22 for details.)	10-: Grade 1 21-: Grade 1					

Note 6) Inlet side pressure: 0.5 MPa, Pressure drop: 0.05 MPa (Representative value).

## Accessory part no.

Accessory	Applicable model	10-/21-AF20	10-/21-AF30	10-/21-AF40	10-/21-AF40-06	10-/21-AF50	10-/21-AF60
Bracket assembly Note 7)		AF20P-050AS	AF30P-050AS	AF40P-050AS	AF40P-070AS	AF50P-050AS	AF50P-050AS

Note 7) Assembly includes a bracket and 2 mounting screws.

Dimensions

10-21-**AF20**

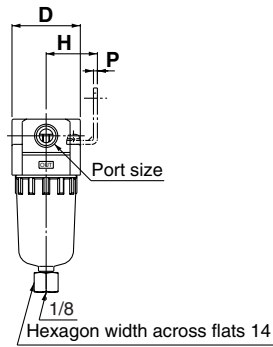
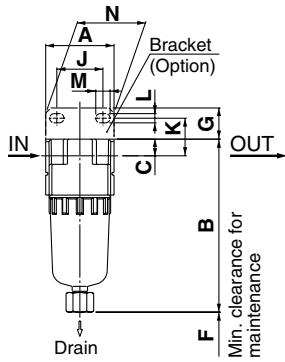

10-21-**AF30 to 40-06**

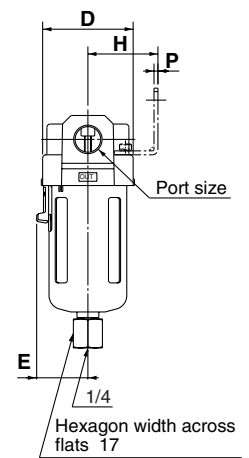
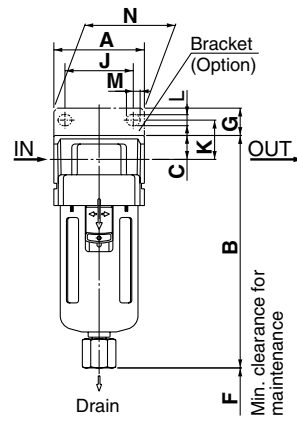

10-21-**AF50/60**

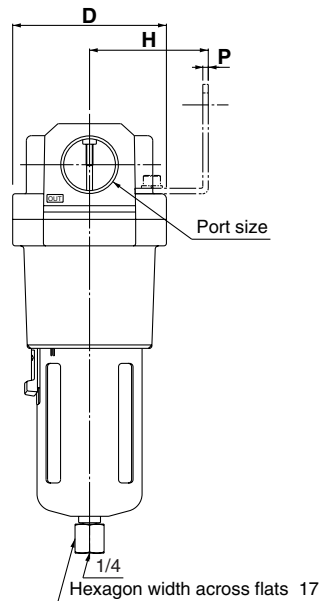
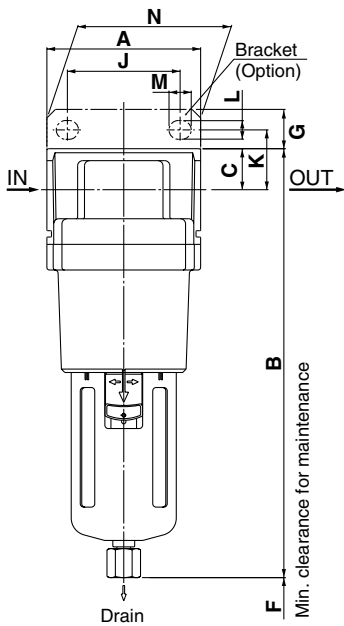

Applicable model	10-21-AF20							10-21-AF30 to 60									
Optional specifications	With bowl guard			Metal bowl				Metal bowl					Metal bowl with level gauge				
Dimensions																	

Model	Port size	Standard specifications							Accessory specifications							Optional specifications		
		A	B	C	D	E	F	Bracket mounting size							With bowl guard	Metal bowl	Metal bowl with level gauge	
								G	H	J	K	L	M	N				P
10-21-AF20	1/8, 1/4	40	101	10	40	—	40	18	30	27	22	5.4	8.4	40	2.3	101	104	—
10-21-AF30	1/4, 3/8	53	136	14	53	30	50	16	41	40	23	6.5	8	53	2.3	—	136	156
10-21-AF40	1/4, 3/8, 1/2	70	172	18	70	38	75	17	50	54	26	8.5	10.5	70	2.3	—	172	192
10-21-AF40-06	3/4	75	176	20	70	38	75	14	50	54	25	8.5	10.5	70	2.3	—	176	196
10-21-AF50	3/4, 1	90	252	24	90	—	20	23	70	66	35	11	13	90	3.2	—	252	272
10-21-AF60	1	95	265	24	95	—	20	23	70	66	35	11	13	90	3.2	—	265	285



# F.R. Precautions 1

Be sure to read before handling.

## Design

### Warning

1. The standard bowl for the air filter and filter regulator are made of polycarbonate. Do not use in an environment where they are exposed to or come in contact with organic solvents, chemicals, cutting oil, synthetic oil, ester based compressor oil, alkali, and thread lock solutions.
2. Avoid applications where pressurized air is frequently introduced to and released from the standard bowl of an air filter, or filter regulator. It may cause the bowl to be damaged. Use of a metal bowl is recommended for such applications.
3. **Regulator and filter regulator**  
Be sure to install a safety device to prevent damage or malfunction of the outlet side components when the output pressure exceeds the set pressure value.

### Caution

1. Select a model that is suitable for desired purity by referring to the SMC's Best Pneumatics catalog.
2. Components cannot be used for applications that are outside the range of specifications. Please consult with SMC when you anticipate using the component outside the range of its specifications (such as temperature and pressure).
3. **Mist separator and micro mist separator**  
Design the system so that the mist separator and micro-mist separator are installed where there is less pulsation. A pressure difference between internal and external pressure inside the element should be kept within 0.1 MPa, as exceeding this value can cause damage.
4. **Regulator and filter regulator**  
Air consumption is 0.1  $\ell$ /min (ANR) or less under standard specifications. Please consult with SMC, if this value is not allowable.

## Selection

### Warning

1. The grease (10-: Fluorine, 21-: Mineral) used on internal sliding parts and seals may run down to outlet side components. Please consult with SMC if this is not desirable.
2. **Regulator and filter regulator**
  - 1) Residual pressure release (outlet pressure release) is not complete by releasing the inlet pressure. To release residual pressure, select a model with a back flow mechanism. Using a model without a back flow mechanism makes for inconsistent residual pressure release (i.e., residual pressure may or may not be released) depending upon the operating conditions.
  - 2) Please contact SMC if air will not be consumed in the system for a long period of time, or if the outlet side will be used with a sealed circuit and a balanced circuit, as this may cause the set pressure of the outlet side to fluctuate.
  - 3) Set the regulating pressure range for the outlet pressure of the regulator in a range that is 85% or less of the inlet pressure. If set to above 85%, the outlet pressure will be easily affected by fluctuations in the flow rate and inlet pressure, and become unstable.
  - 4) A safety margin is calculated into the maximum set pressure range appearing in the catalog's specification table. Therefore, the outlet pressure may exceed the set pressure.
  - 5) Please contact SMC when a circuit requires relief sensitivity or setting accuracy with high precision.



# F.R. Precautions 2

Be sure to read before handling.

## Mounting

### ⚠ Caution

1. To avoid reversed connections of the air inlet/outlet, make connections after confirming the "IN/OUT" mark or arrows that indicate the direction of air flow. Reversed connections can cause malfunction.
2. Components with a bowl, e.g., air filter, filter regulator must be installed vertically with the bowl downward so that faulty drain discharge and dripping can be verified.
3. Ensure sufficient top, bottom, and front clearance for maintenance and operation of each component. Refer to the dimensions section for the minimum clearance for each component.
4. **Regulator and filter regulator**  
Be sure to unlock the knob before adjusting the pressure and to lock it after the pressure is set.
5. **Drain piping**
  - 1) The drain guide bowl of a filter or filter regulator is not provided with a valve function to exhaust drainage. Install valves onto the drain guide before supplying air to discharge air and drainage.
  - 2) When piping the drain guide bowl of the filter or filter regulator, first secure the drain guide with a wrench. Failure to secure the drain guide may result in bowl damage.

## Air supply

### ⚠ Caution

1. **When there is excessive drainage**  
Install the dryer or water separator (Drain Catch) before the air filter or filter regulator.

## Adjustment

### ⚠ Warning

#### 1. Regulator and filter regulator

- 1) Set the regulator while verifying the displayed values of the inlet and outlet pressure gauges. Turning the knob excessively can cause damage to the internal parts.
- 2) Do not use a tool on the pressure regulator knob as this can cause damage. It must be operated manually.

### ⚠ Caution

#### 1. Regulator and filter regulator

- 1) Be sure to check the inlet pressure before setting the outlet pressure.
- 2) The pressure gauge included with regulators for 0.02 to 0.2 MPa setting is for up to 0.2 MPa only. Do not apply pressure exceeding 0.2 MPa. It can damage the pressure gauge.
- 3) To set the pressure using the knob, turn the knob in the direction that increases pressure and lock the knob after the pressure is set. If this is done in the direction that decreases pressure, the pressure may drop from the original set pressure. Turning the knob clockwise increases the outlet pressure, and turning it counterclockwise reduces the pressure.

## Piping

### ⚠ Warning

1. To screw piping materials into components, tighten with a recommended tightening torque while holding the female thread side. If the minimum tightening torque is not observed, this can cause a looseness and seal failure. On the other hand, excess tightening torque can cause damage to the thread. Furthermore, tightening without holding the female thread side can cause damage due to the excess force that is applied directly to the piping bracket.

### Recommended tightening torque

Unit: N·m

Connection thread	1/8	1/4	3/8	1/2	3/4	1
Torque	7 to 9	12 to 14	22 to 24	28 to 30	28 to 30	36 to 38

Air cylinder

Rotary actuator

Air gripper

Directional control valve

Flow control equipment

Filter, Pressure control equipment

Fittings & Tubing

Air preparation equipment

Pressure switch

Clean gas filter



# F.R. Precautions 3

Be sure to read before handling.

## Maintenance

### Warning

1. When disassembly or installation is required during the maintenance, repair, or replacement of a device, be sure to follow the instructions provided in the instruction manual or safety instructions in this catalog.
2. Perform periodical inspections to detect any cracks, scratches, or other deterioration of the transparent resin bowl of the air filter and filter regulator.  
Replace with a new bowl or metal bowl when any kind of deterioration is found, otherwise this can cause damage.
3. Perform periodical inspections to detect dirt on the transparent resin bowl of the air filter and filter regulator. When you find dirt on any of the above devices, clean with a household neutral detergent. Do not use other cleaning agents, otherwise this can cause damage.
4. **Air filter**
  - 1) Replace the element every 2 years or when the pressure drop becomes 0.1 MPa, whichever comes first, to prevent damage to the element.
  - 2) Release accumulated condensate periodically before it reaches the maximum capacity. Condensate that flows out to the outlet side can cause malfunctions.
5. **Mist separator and micro mist separator**
  - 1) Replace the element every 2 years or when the pressure drop becomes 0.1 MPa, whichever comes first, to prevent damage to the element.
  - 2) Release accumulated condensate periodically before it reaches the maximum capacity. Condensate that flows out to the outlet side can cause malfunctions.

### Caution

1. Perform periodical inspections of the filter element and replace it as necessary. Check the element whenever the outlet pressure drops below normal or air does not flow smoothly during operation.
2. **Regulator and filter regulator**  
Check the sliding part or seat of the internal valve when a setting malfunction or relief leakage occur and temporary or emergency repairs need to be made.